



US00D542631S

(12) **United States Design Patent**  
**Munson et al.**

(10) **Patent No.:** **US D542,631 S**

(45) **Date of Patent:** **\*\* May 15, 2007**

(54) **WALL HANGER**

(75) Inventors: **Leslie C. Munson**, San Juan Capistrano, CA (US); **Steve A. Kumetz**, Los Angeles, CA (US); **James M. Gallien**, Hidden Hills, CA (US)

(73) Assignee: **Hangman Products, Inc.**, Woodland Hills, CA (US)

(\*\*) Term: **14 Years**

(21) Appl. No.: **29/224,946**

(22) Filed: **Mar. 8, 2005**

(51) **LOC (8) Cl.** ..... **08-05**

(52) **U.S. Cl.** ..... **D8/373**

(58) **Field of Classification Search** ..... D8/373;  
248/475.1, 477; D25/119

See application file for complete search history.

(56) **References Cited**

U.S. PATENT DOCUMENTS

D198,471 S	*	6/1964	Rankin, Jr.	.....	D8/381
D227,981 S		7/1973	La Borde		
4,228,982 A		10/1980	Sellera		
4,597,554 A		7/1986	James		
4,606,526 A		8/1986	Rabinowitz		
4,712,761 A	*	12/1987	Wassell	.....	248/475.1
5,209,449 A		5/1993	Hart		
5,303,895 A		4/1994	Hart		
D357,407 S		4/1995	Pate		

5,480,120 A		1/1996	Bruner		
5,791,625 A		8/1998	Orser		
5,802,729 A		9/1998	O'Brien		
5,947,438 A		9/1999	Lemire		
5,961,090 A	*	10/1999	Parkin	.....	248/475.1
6,286,802 B1	*	9/2001	Munson et al.	.....	248/475.1
6,322,039 B1	*	11/2001	De Luccia	.....	248/553
D479,008 S	*	8/2003	Krieger	.....	D25/136
6,609,693 B2		8/2003	Hui		
2003/0038222 A1	*	2/2003	Holmes	.....	248/475.1

\* cited by examiner

*Primary Examiner*—Holly H. Baynham

(74) *Attorney, Agent, or Firm*—Stetina Brunda Garred & Brucker

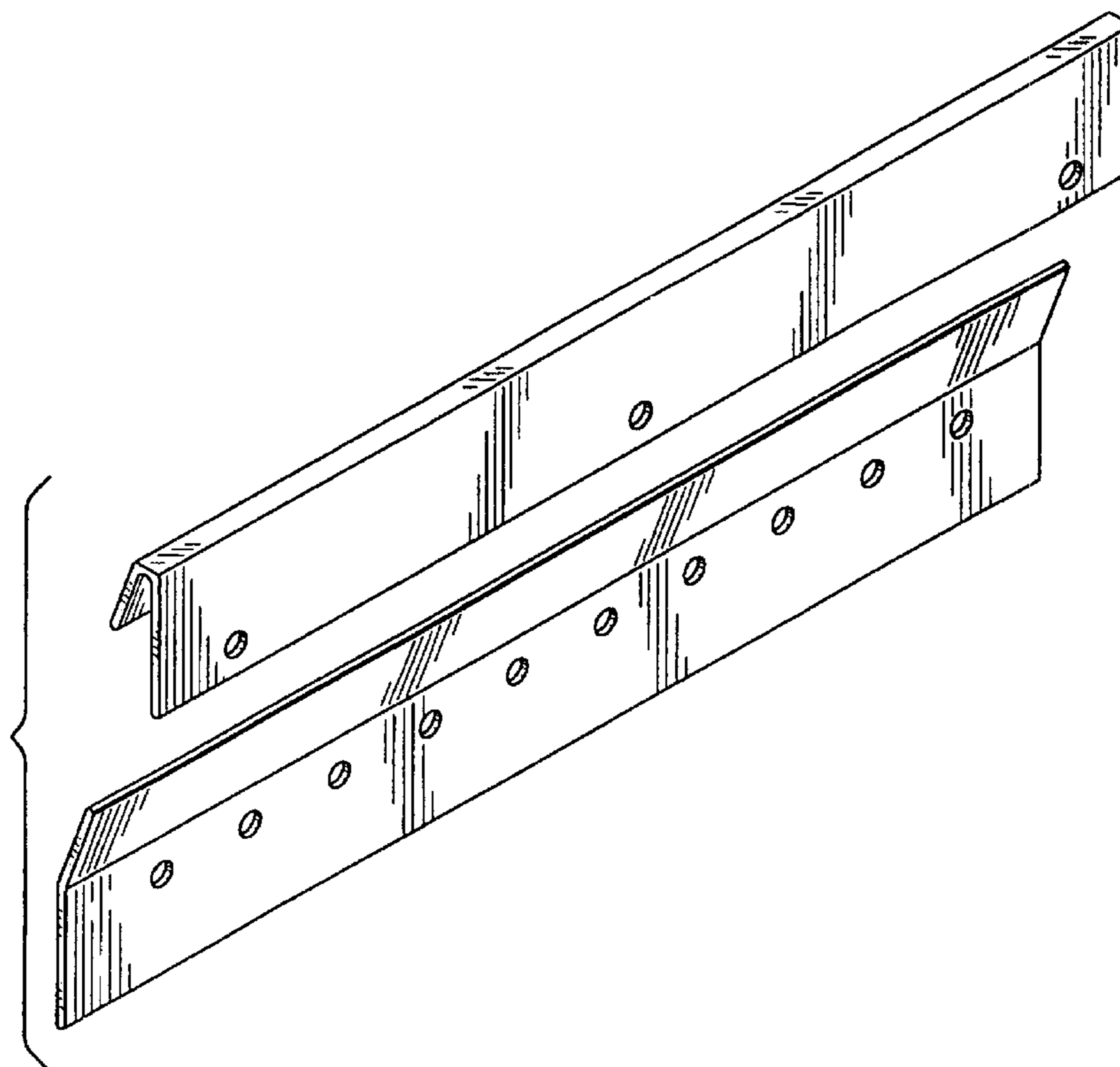
(57) **CLAIM**

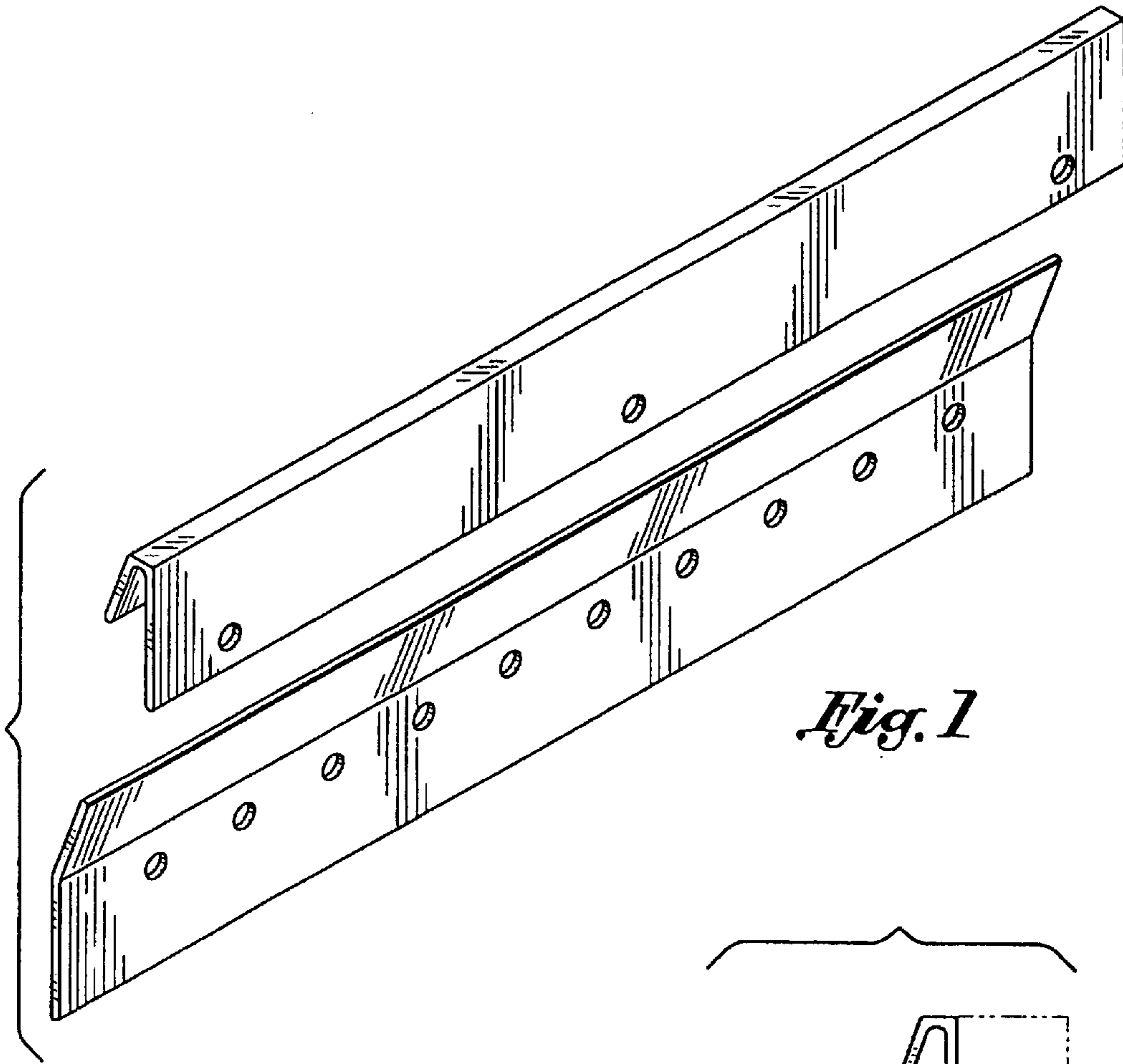
The ornamental design for a wall hanger, as shown and described.

**DESCRIPTION**

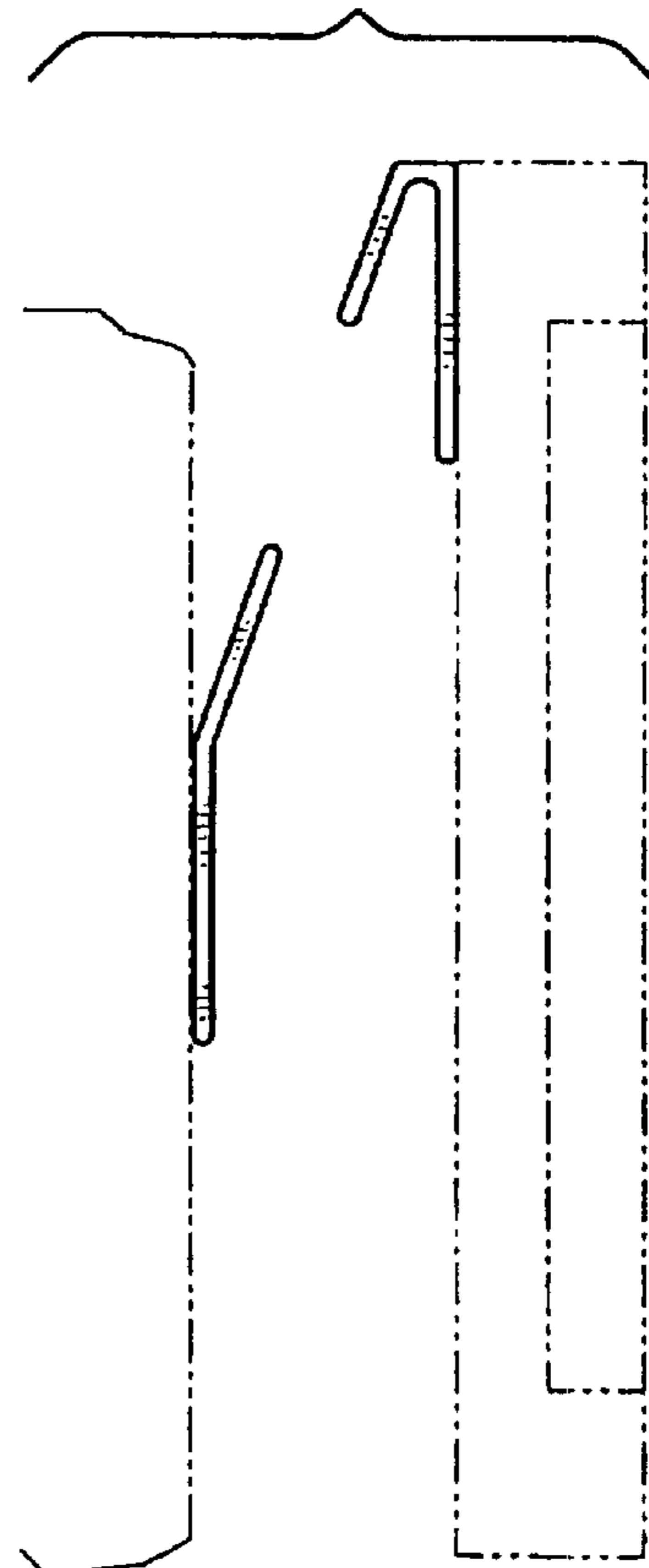
FIG. 1 is an exploded perspective view of the wall hanger of the present invention showing our new design; FIG. 2 is a side elevational view thereof with the phantom lines depicting solely environmental structure and forming no part of the claimed design; FIG. 3 is a top plan view thereof; FIG. 4 is a front elevational view thereof; FIG. 5 is a rear elevational view thereof; and, FIG. 6 is a bottom plan view thereof.

**1 Claim, 3 Drawing Sheets**

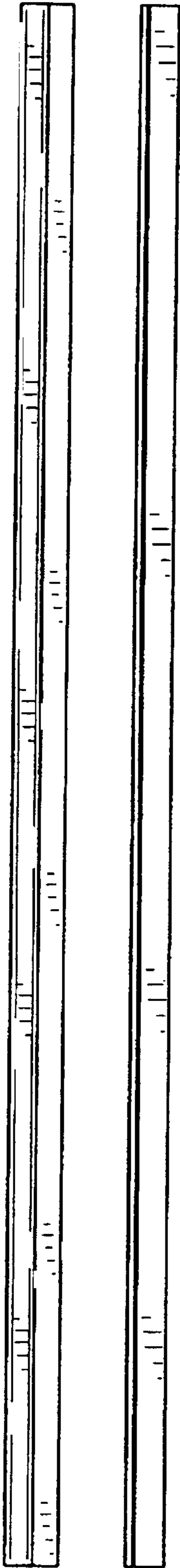




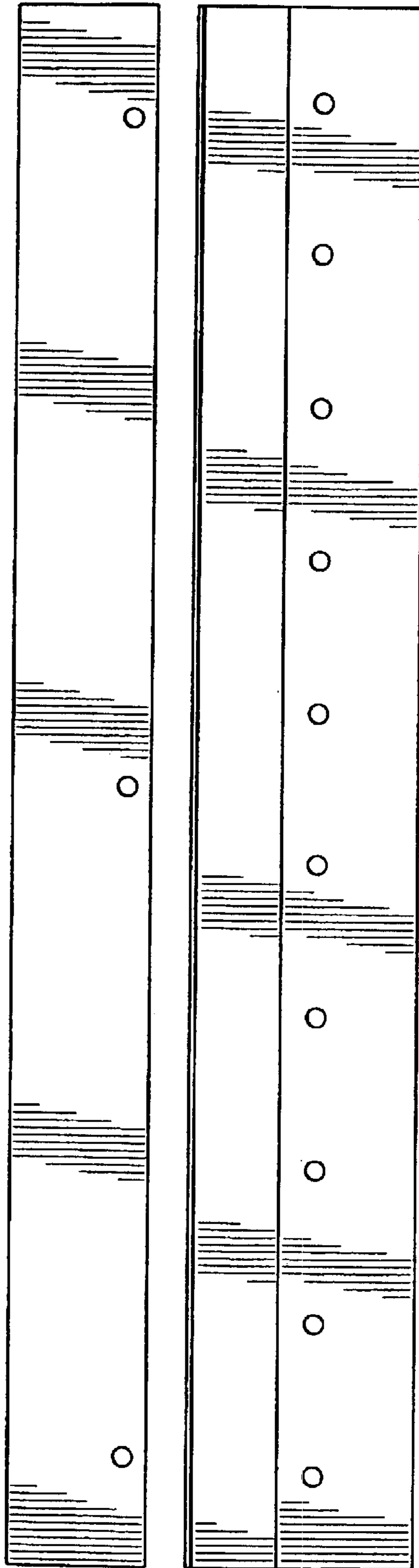
*Fig. 1*



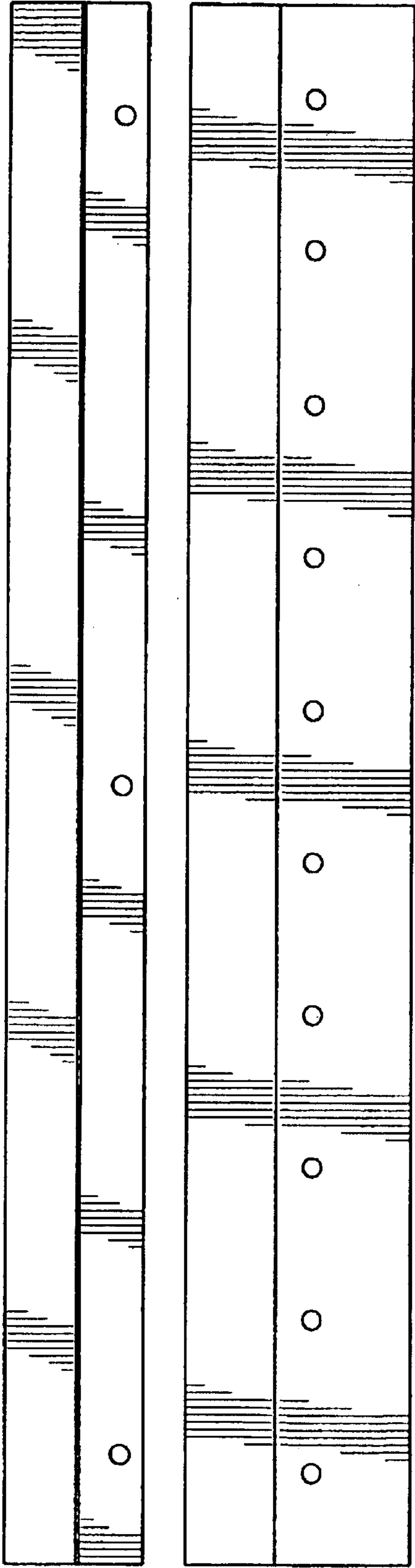
*Fig. 2*



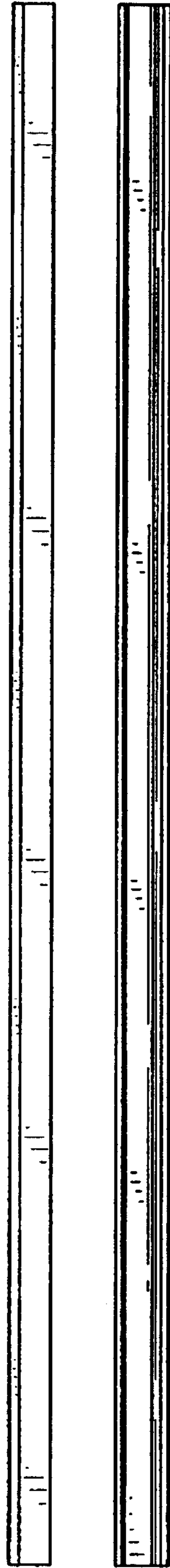
*Fig. 3*



*Fig. 4*



*Fig. 5*



*Fig. 6*