



US00D542445S

(12) **United States Design Patent**
Matsunami

(10) **Patent No.:** **US D542,445 S**

(45) **Date of Patent:** **** May 8, 2007**

(54) **REAR COMBINATION LAMP OF
AUTOMOBILES**

D476,434 S * 6/2003 Lin D26/28
D477,886 S * 7/2003 Lin D26/28
D478,182 S * 8/2003 Lin D26/28

(75) Inventor: **Hiroshi Matsunami**, Wako (JP)

* cited by examiner

(73) Assignee: **Honda Motor Co., Ltd.**, Tokyo (JP)

Primary Examiner—Marcus A. Jackson

(**) Term: **14 Years**

(74) *Attorney, Agent, or Firm*—Birch, Stewart, Kolasch & Birch, LLP

(21) Appl. No.: **29/263,706**

(57) **CLAIM**

(22) Filed: **Jul. 28, 2006**

The ornamental design for a rear combination lamp of automobiles, as shown and described.

(30) **Foreign Application Priority Data**

Mar. 28, 2006 (JP) 2006-007830

DESCRIPTION

(51) **LOC (8) Cl.** **26-06**

(52) **U.S. Cl.** **D26/28**

(58) **Field of Classification Search** D26/28–36;
362/459–468, 475–478, 485–487

See application file for complete search history.

FIG. 1 is a front view of a rear combination lamp of automobiles showing my new design; FIG. 2 is a left side view thereof; and, FIG. 3 is a front perspective view thereof.

The broken lines shown in FIGS. 1–3 are for the purpose of showing environmental structure only and form no part of the claimed design.

(56) **References Cited**

U.S. PATENT DOCUMENTS

D467,020 S * 12/2002 Lin D26/28

1 Claim, 2 Drawing Sheets

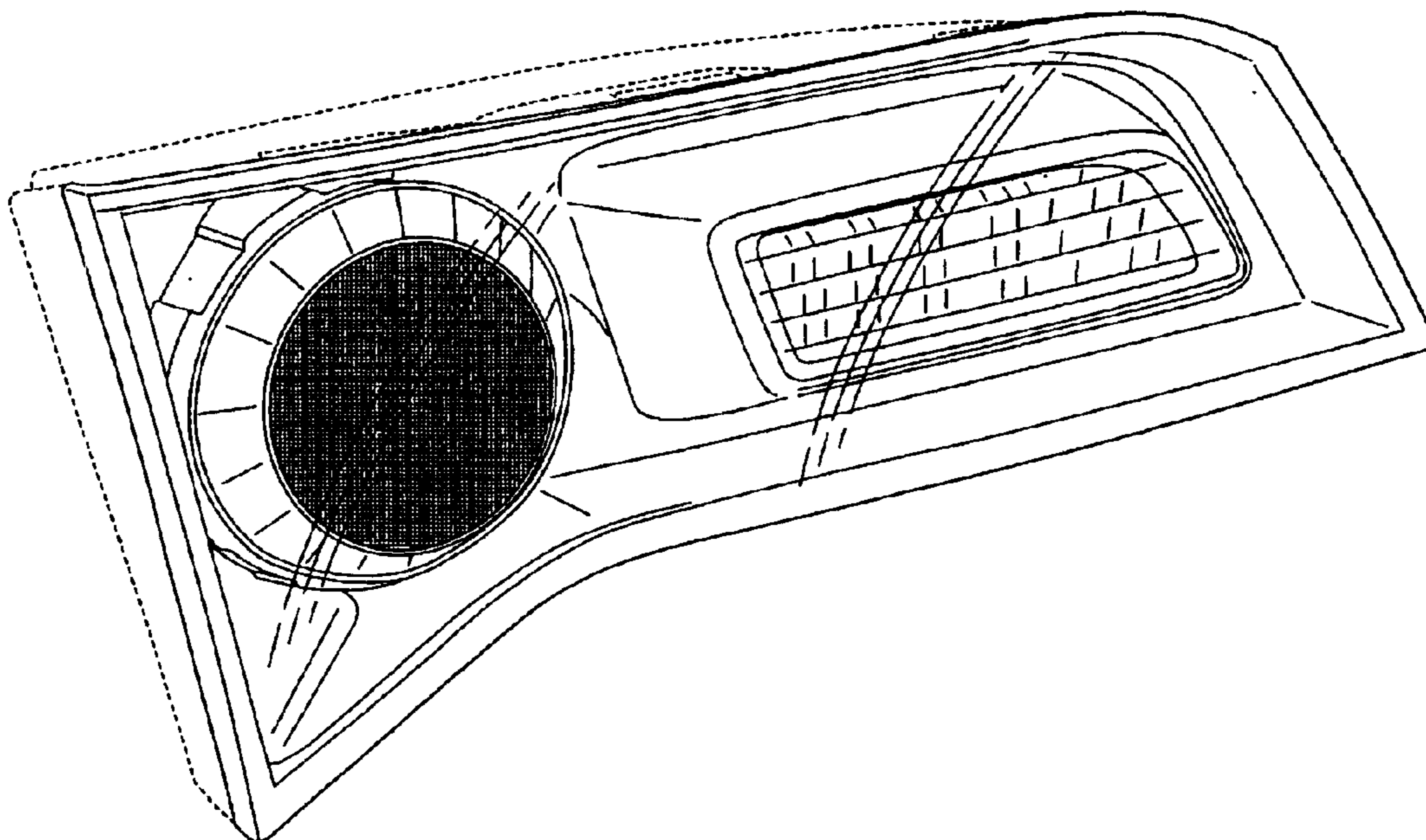

FIG.1

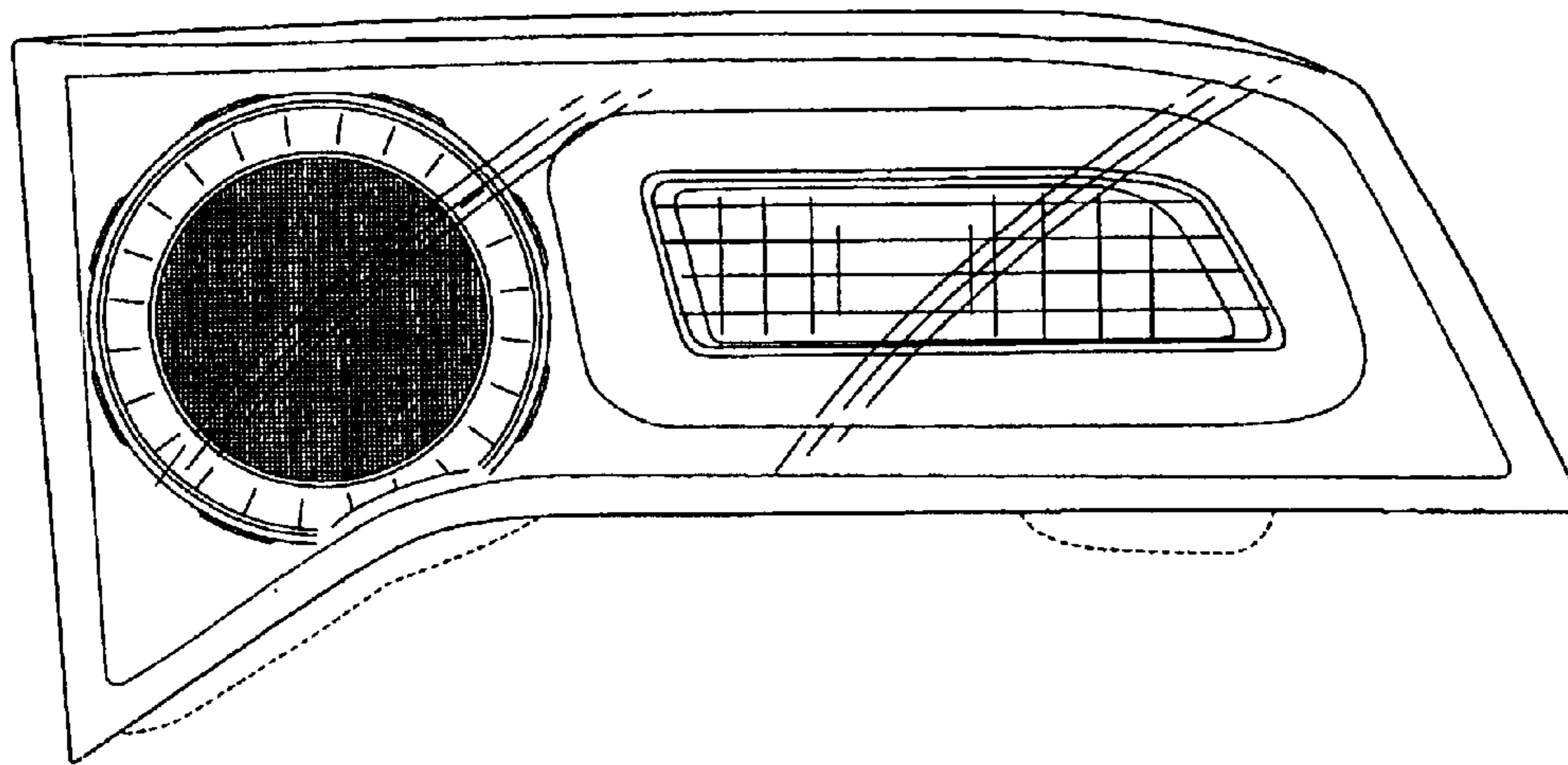

FIG.2

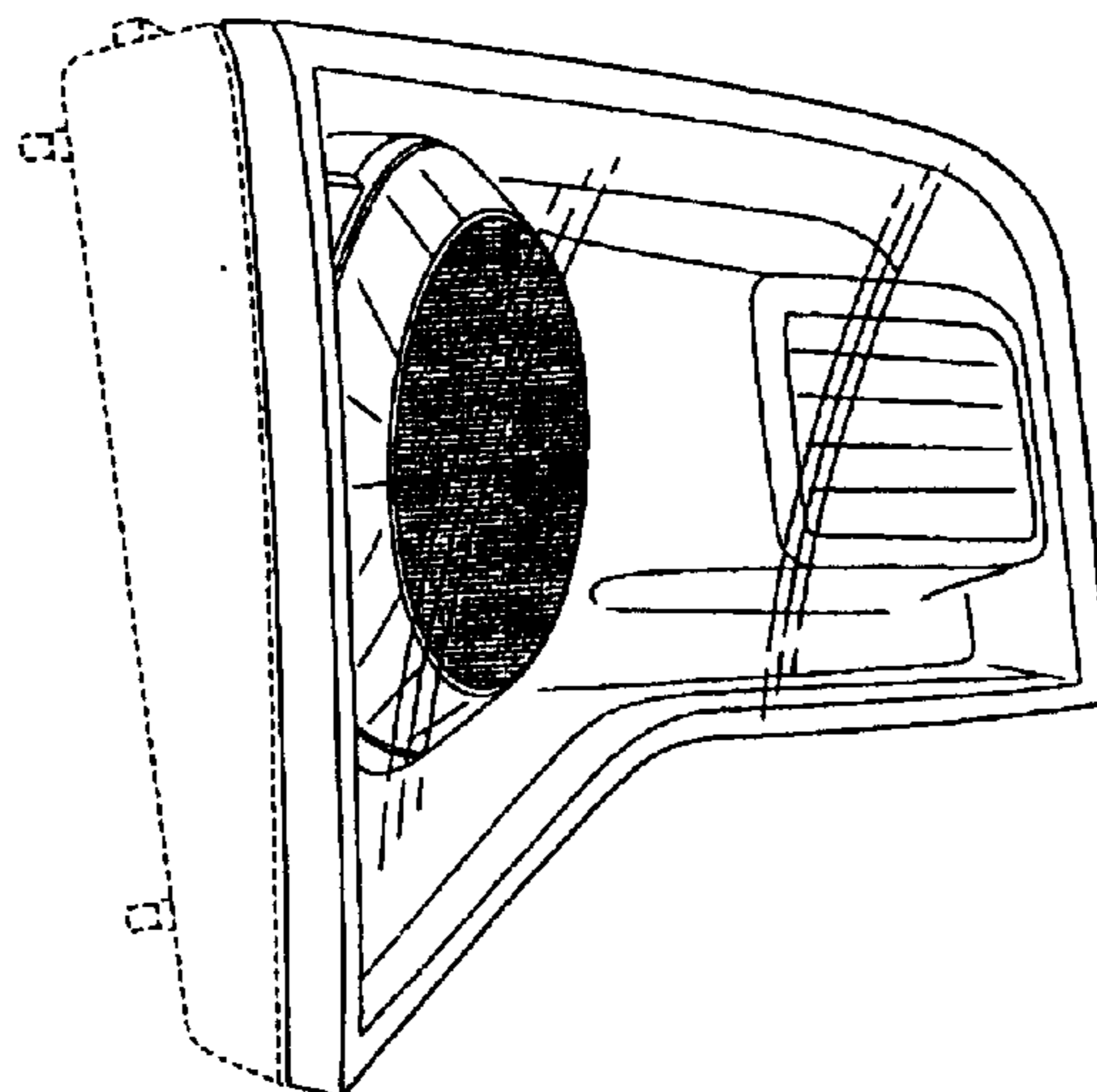

FIG.3

