

US00D542276S

(12) **United States Design Patent**
Hibino

(10) **Patent No.:** **US D542,276 S**

(45) **Date of Patent:** **** May 8, 2007**

(54) **SPEAKER BOX**

(75) Inventor: **Takuro Hibino**, Tokyo (JP)

(73) Assignee: **Sony Corporation**, Tokyo (JP)

(**) Term: **14 Years**

(21) Appl. No.: **29/251,595**

(22) Filed: **Jan. 11, 2006**

(51) **LOC (8) Cl.** **14-01**

(52) **U.S. Cl.** **D14/215; D14/214**

(58) **Field of Classification Search** D14/204,
D14/209-216; 181/143-144, 147-148, 150,
181/157, 198-199, 151, 153; 381/300-302,
381/306, 333, 345, 361-364, 386-388, 332,
381/336

See application file for complete search history.

(56) **References Cited**

U.S. PATENT DOCUMENTS

D379,629 S	*	6/1997	Watson et al.	D14/215
D384,668 S		10/1997	Yoneda	
D422,593 S	*	4/2000	Ito et al.	D14/214
D437,307 S		2/2001	Tejima	
D470,474 S	*	2/2003	Kobayashi	D14/215
D484,115 S	*	12/2003	Nishii et al.	D14/215

OTHER PUBLICATIONS

Web page "MHC-RG575S" <http://www.sony.co.za/prod.asp?DTID=0&CID=51&SID=125&PID=1402> , 2 sheets, Sony (Nov. 2005).

Web page "MHC-GNX60" <http://www.sony.cl/corporate?model=MHC-GNX60&page=productosDetalles#>, 2 shetts, Sony (Nov. 2005).

* cited by examiner

Primary Examiner—Nanda Bondade

(74) *Attorney, Agent, or Firm*—Grauer Fishman & Grauer PLLC

(57) **CLAIM**

The ornamental design for a speaker box, as shown.

DESCRIPTION

FIG. 1 is a perspective view of a speaker box showing my new design;

FIG. 2 is a front elevational view thereof;

FIG. 3 is a rear elevational view thereof;

FIG. 4 is a left side elevational view thereof;

FIG. 5 is a right side elevational view thereof;

FIG. 6 is a top plan view thereof; and,

FIG. 7 is a bottom plan view thereof.

1 Claim, 7 Drawing Sheets

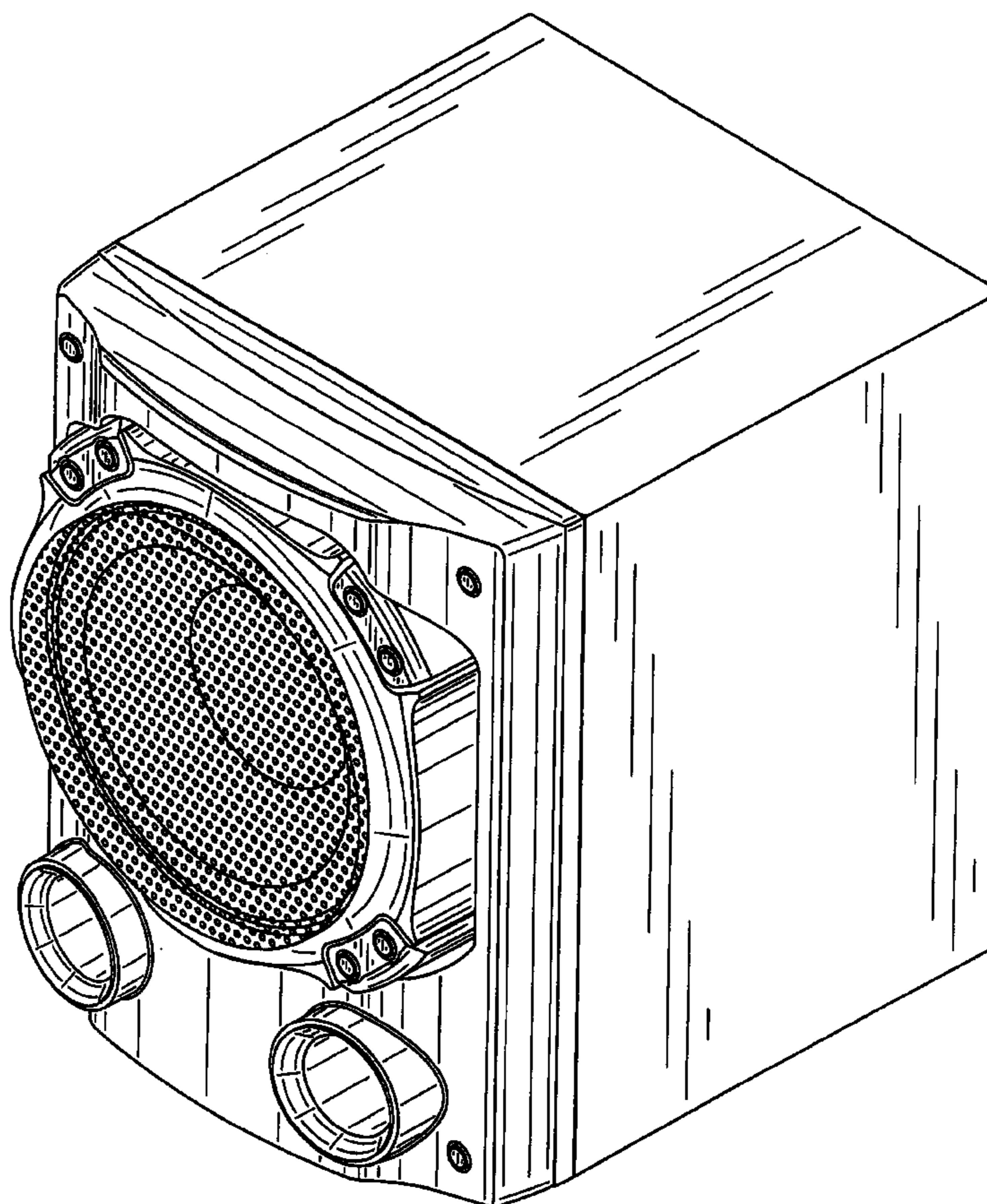

Fig.1

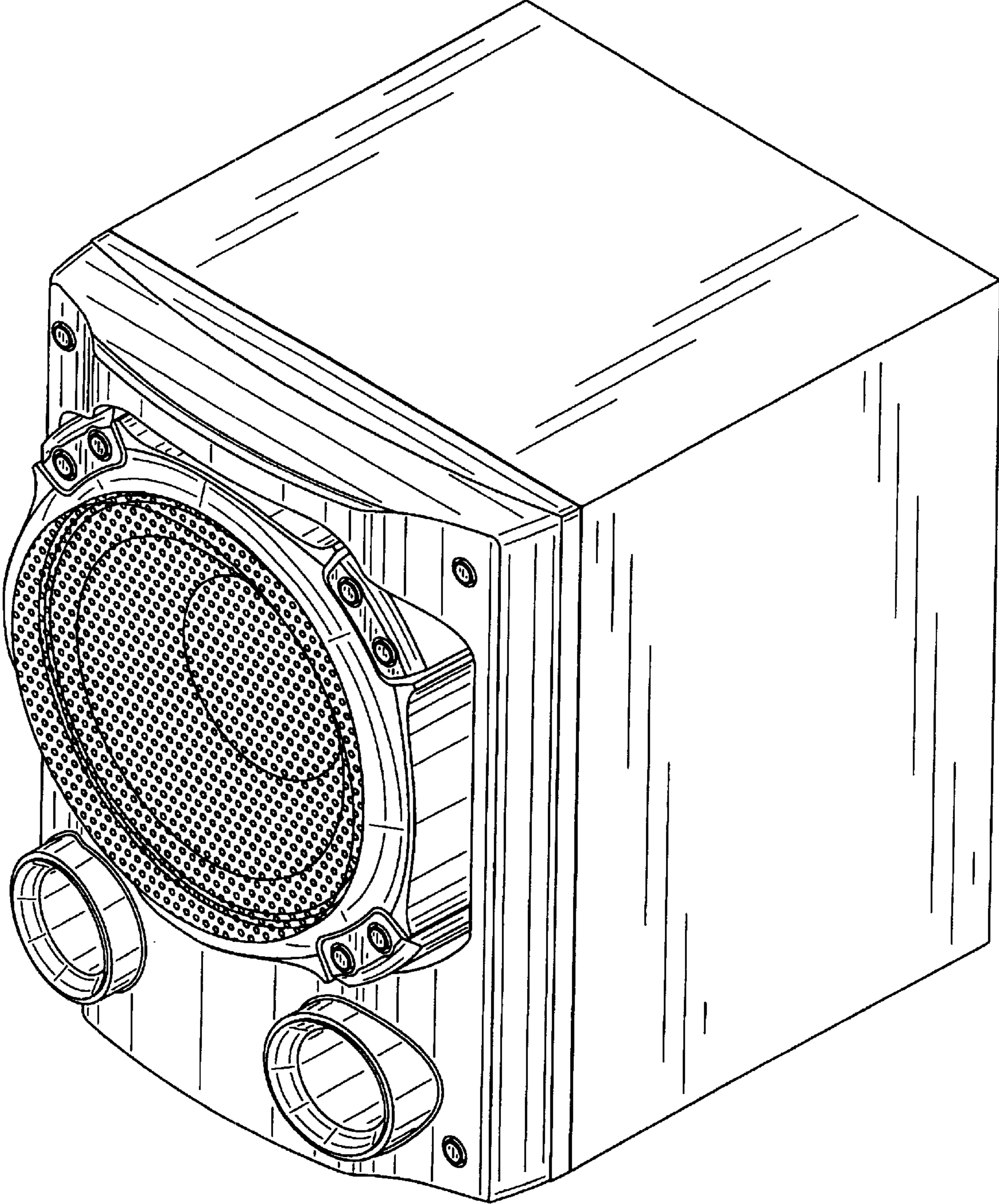

Fig.2

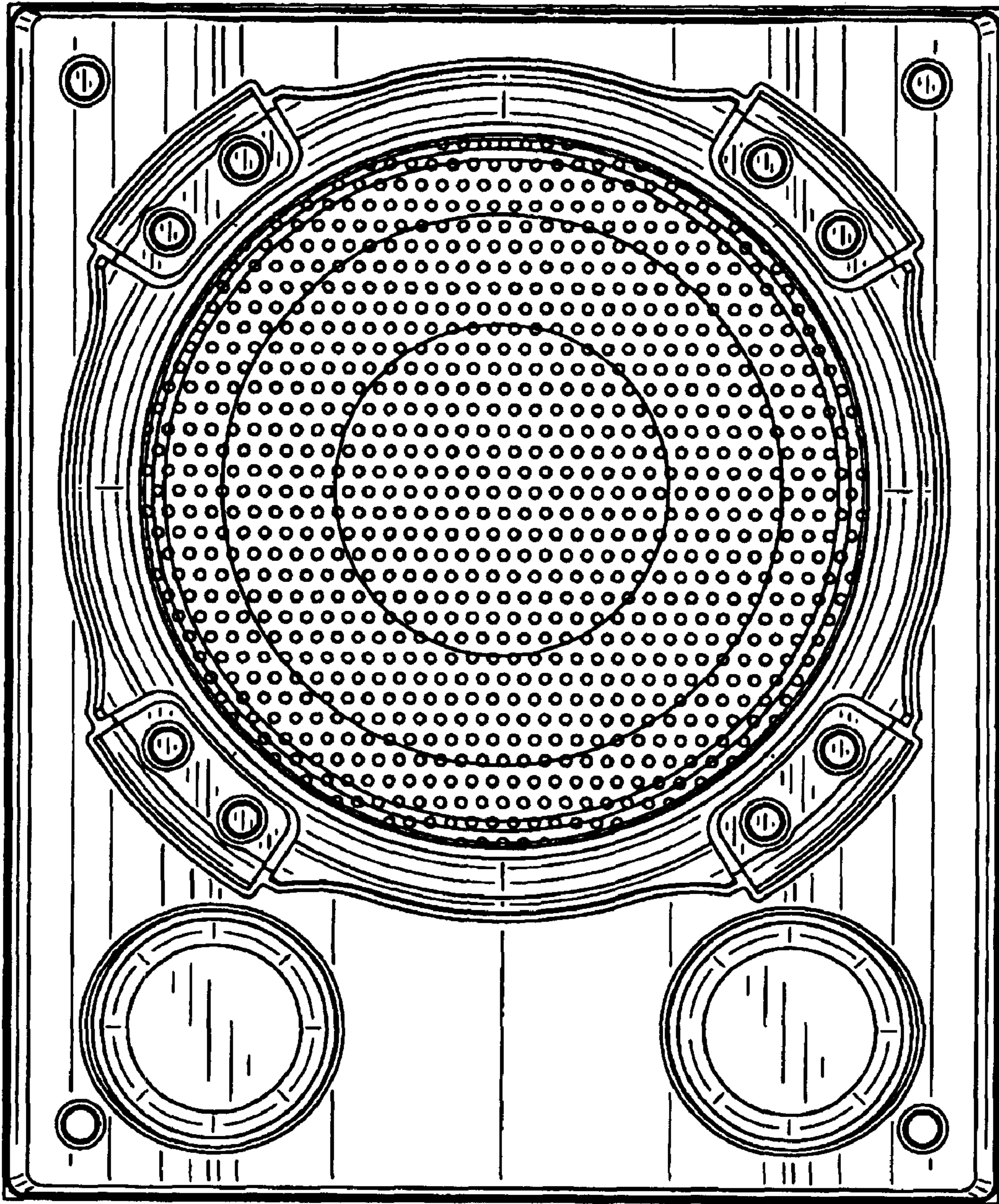

Fig.3

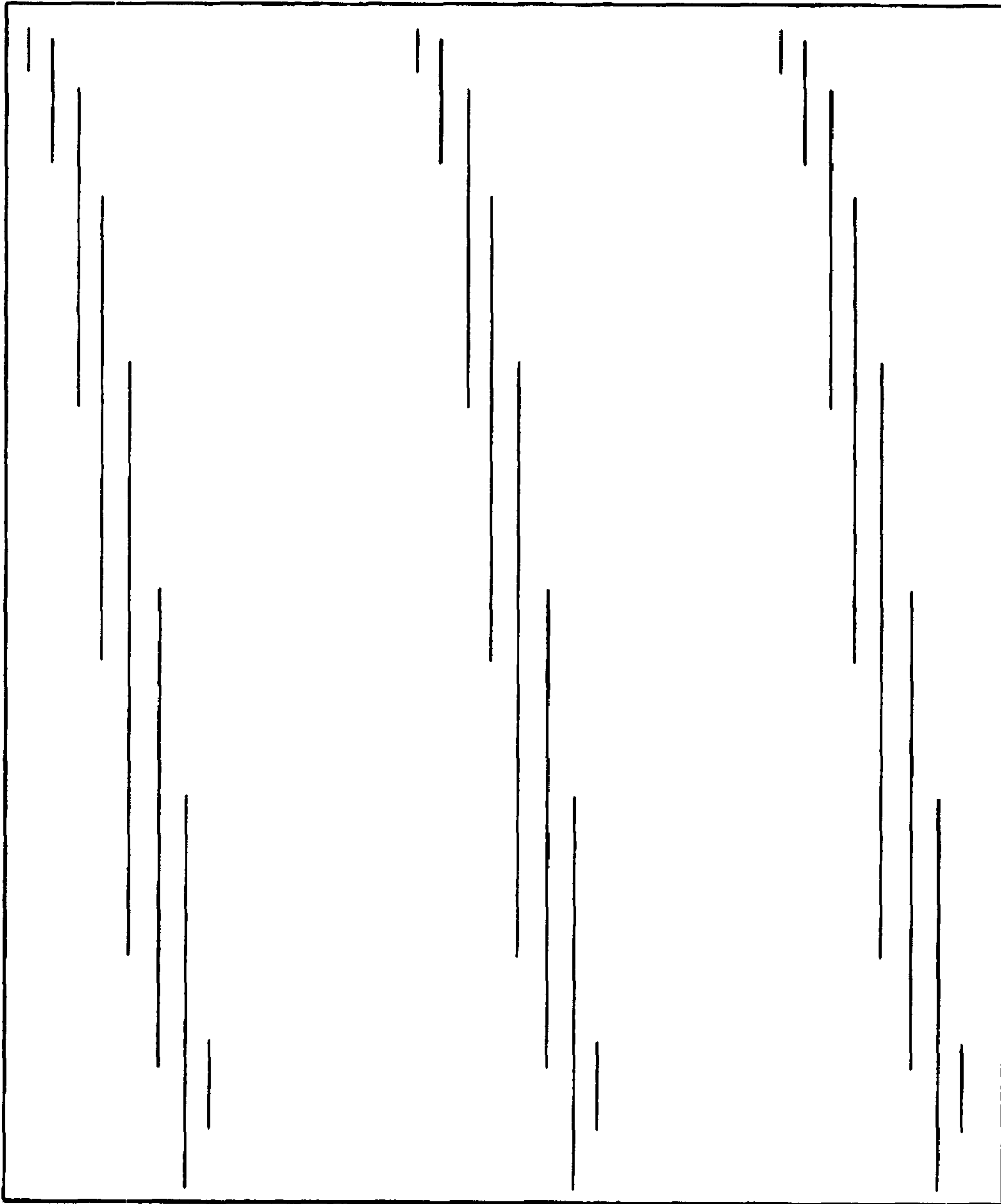

Fig.4

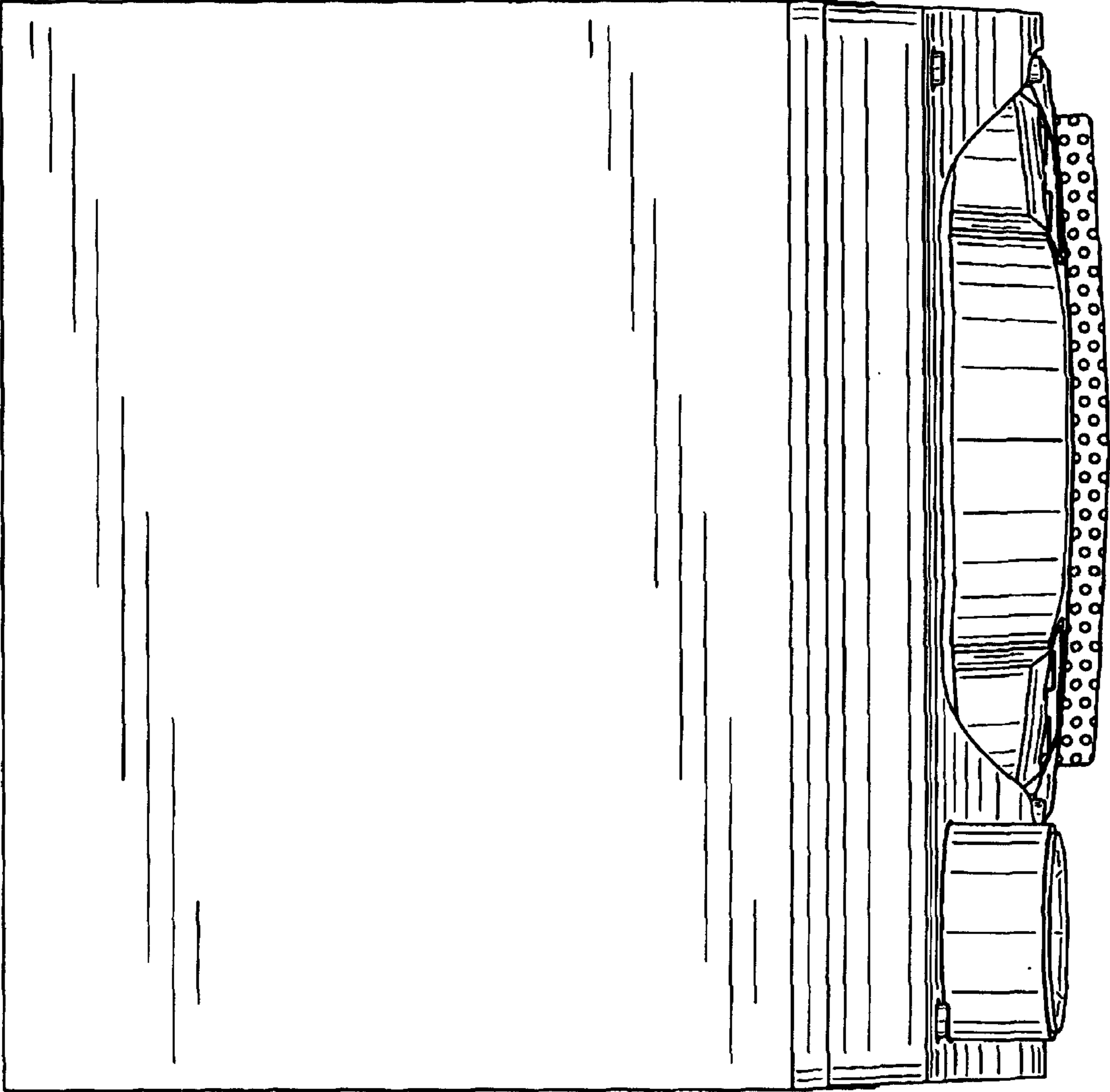

Fig.5

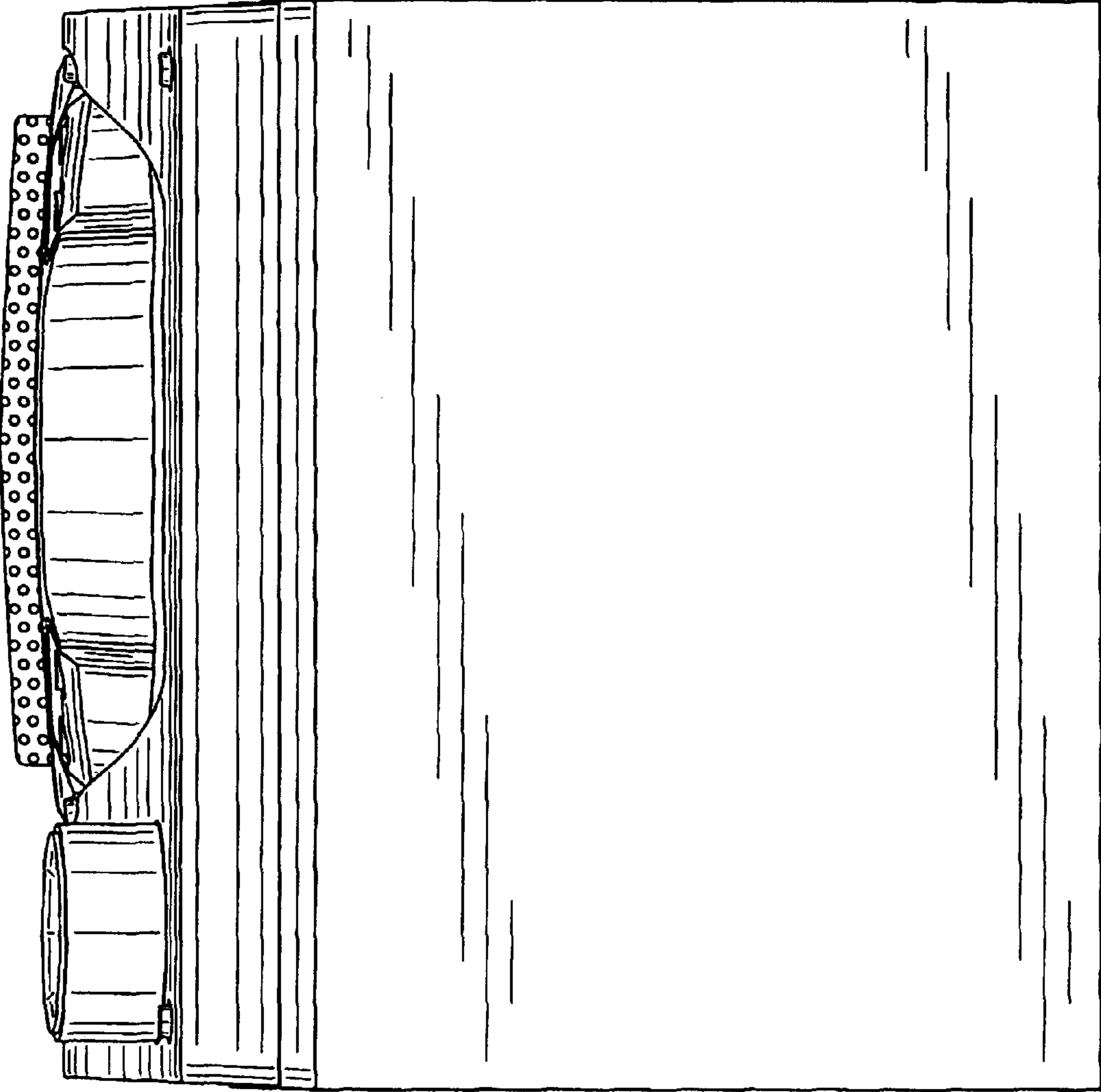

Fig.6

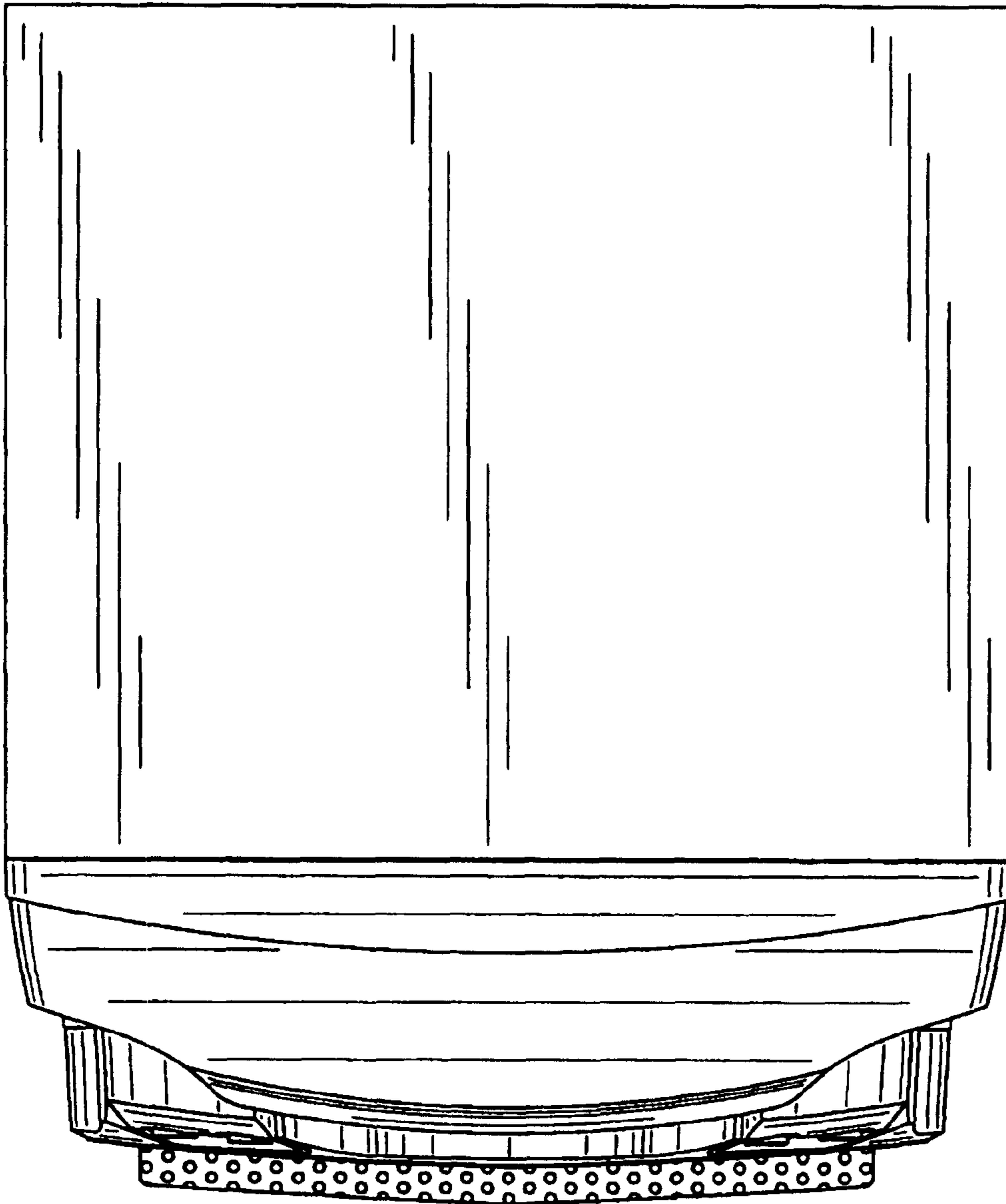

Fig.7

