

US00D542198S

(12) **United States Design Patent**
Goodman et al.

(10) **Patent No.:** **US D542,198 S**

(45) **Date of Patent:** **** May 8, 2007**

(54) **HANDLE FOR TOWED VEHICLE
AUXILIARY BRAKING SYSTEM**

D477,553 S 7/2003 Brock et al.
6,634,466 B1 10/2003 Brock et al.
D490,349 S 5/2004 Brock et al.
D498,190 S 11/2004 Brock et al.

(75) Inventors: **Steven Goodman**, Pender, NE (US);
Klint Bremer, Waverly, NE (US)

* cited by examiner

(73) Assignee: **Automatic Equipment Manufacturing
Company**, Pender, NE (US)

Primary Examiner—Stacia Cadmus

(74) *Attorney, Agent, or Firm*—Donald R. Schoonover

(**) Term: **14 Years**

(57) **CLAIM**

(21) Appl. No.: **29/262,678**

We claim the ornamental design for a handle for towed vehicle auxiliary braking system, as shown and described.

(22) Filed: **Jul. 10, 2006**

DESCRIPTION

(51) **LOC (8) Cl.** **12-16**

(52) **U.S. Cl.** **D12/180**

(58) **Field of Classification Search** D12/179,
D12/180, 400; D8/300, 315, 316, 319, 320;
D15/4; 303/16, 20, 7; 188/3 R, 352, 345,
188/73.31, 73.45

See application file for complete search history.

FIG. 1 is a top, side and front perspective view of a handle for towed vehicle auxiliary braking system showing our new design;

FIG. 2 is a front elevational view thereof;

FIG. 3 is a top plan view thereof;

FIG. 4 is a bottom plan view thereof;

FIG. 5 is a left side elevational view thereof, the elevational view of the right side being a mirror image thereof;

FIG. 6 is a rear elevational view thereof; and,

FIG. 7 is a top, side and front perspective view showing the handle for towed vehicle auxiliary braking system in use; the broken lines depict environmental structure for illustrative purposes only and form no part of the claimed design.

(56) **References Cited**

U.S. PATENT DOCUMENTS

D308,525 S * 6/1990 Robbins D15/4
D380,956 S * 7/1997 Collins D8/316
6,126,246 A 10/2000 Decker, Sr. et al.
D468,243 S * 1/2003 Iida D12/180

1 Claim, 4 Drawing Sheets

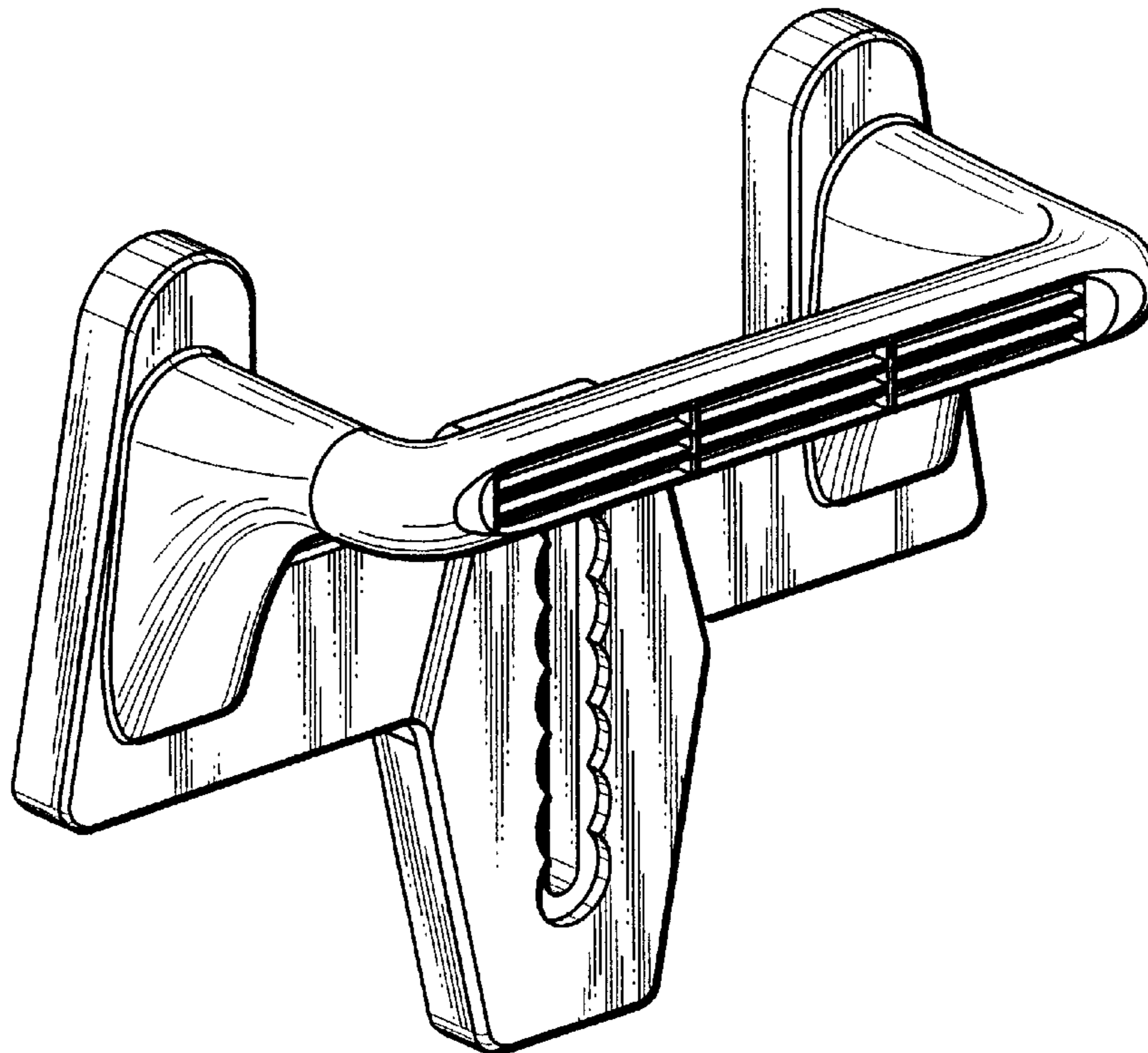

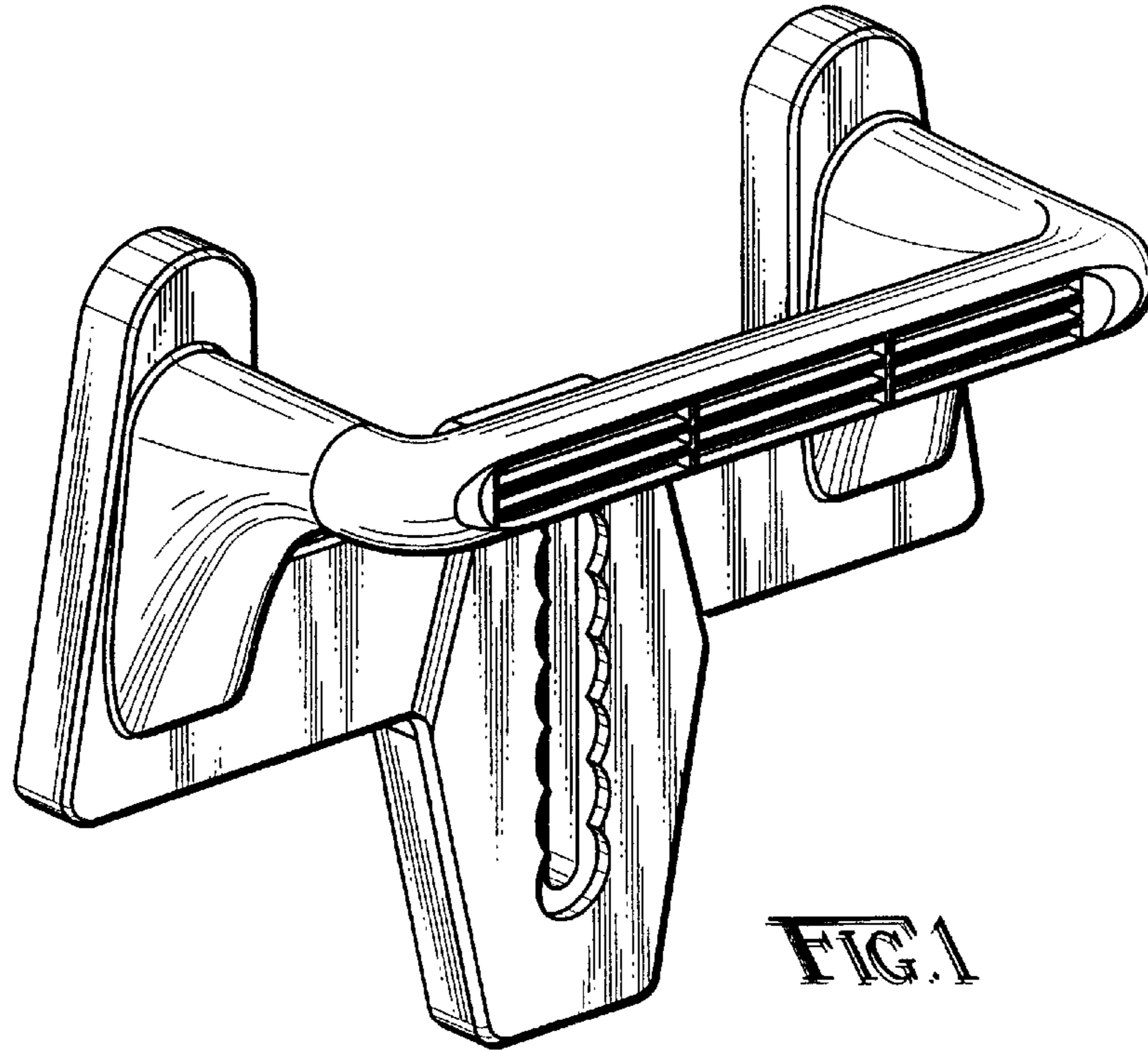

FIG. 1

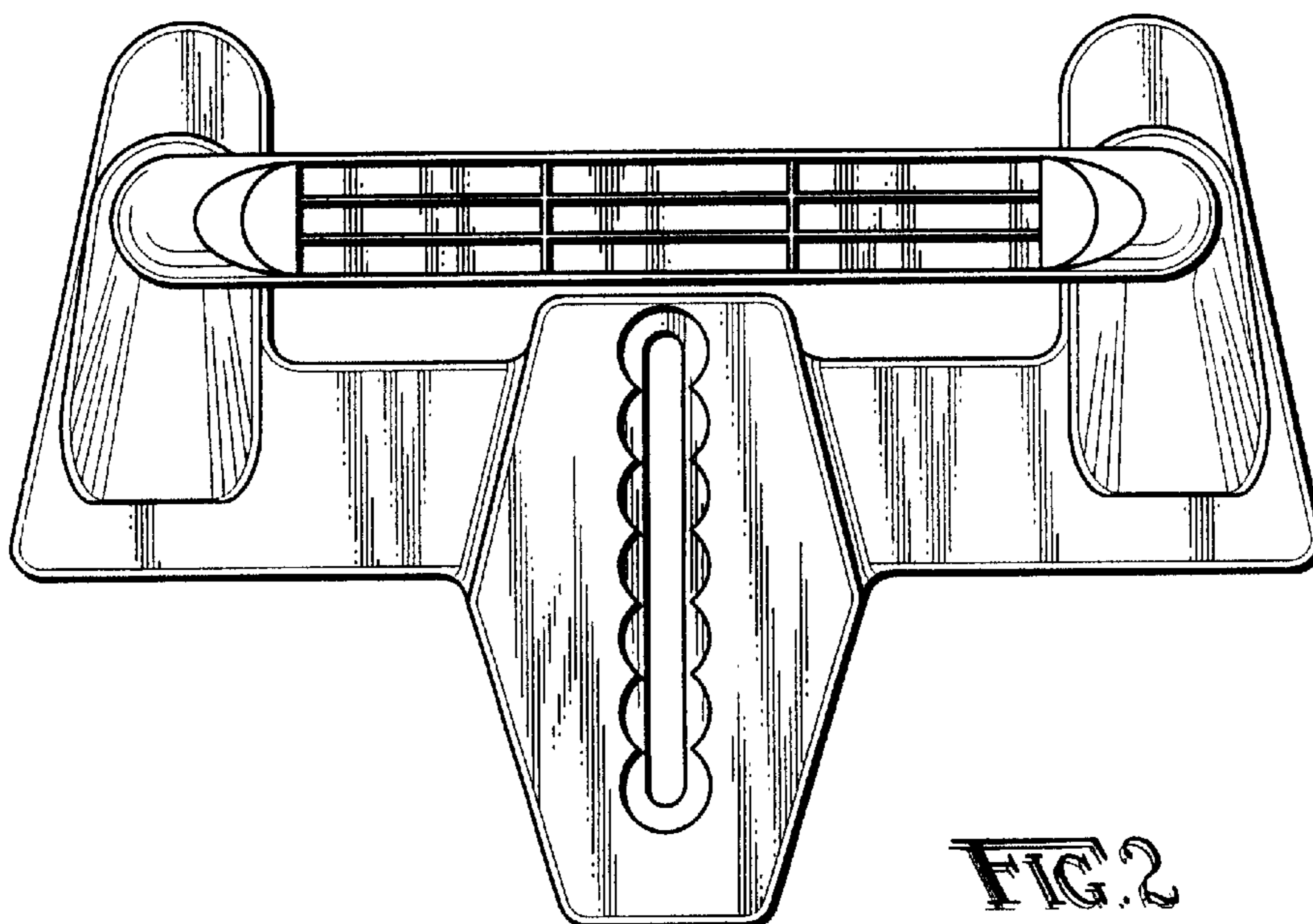

FIG. 2

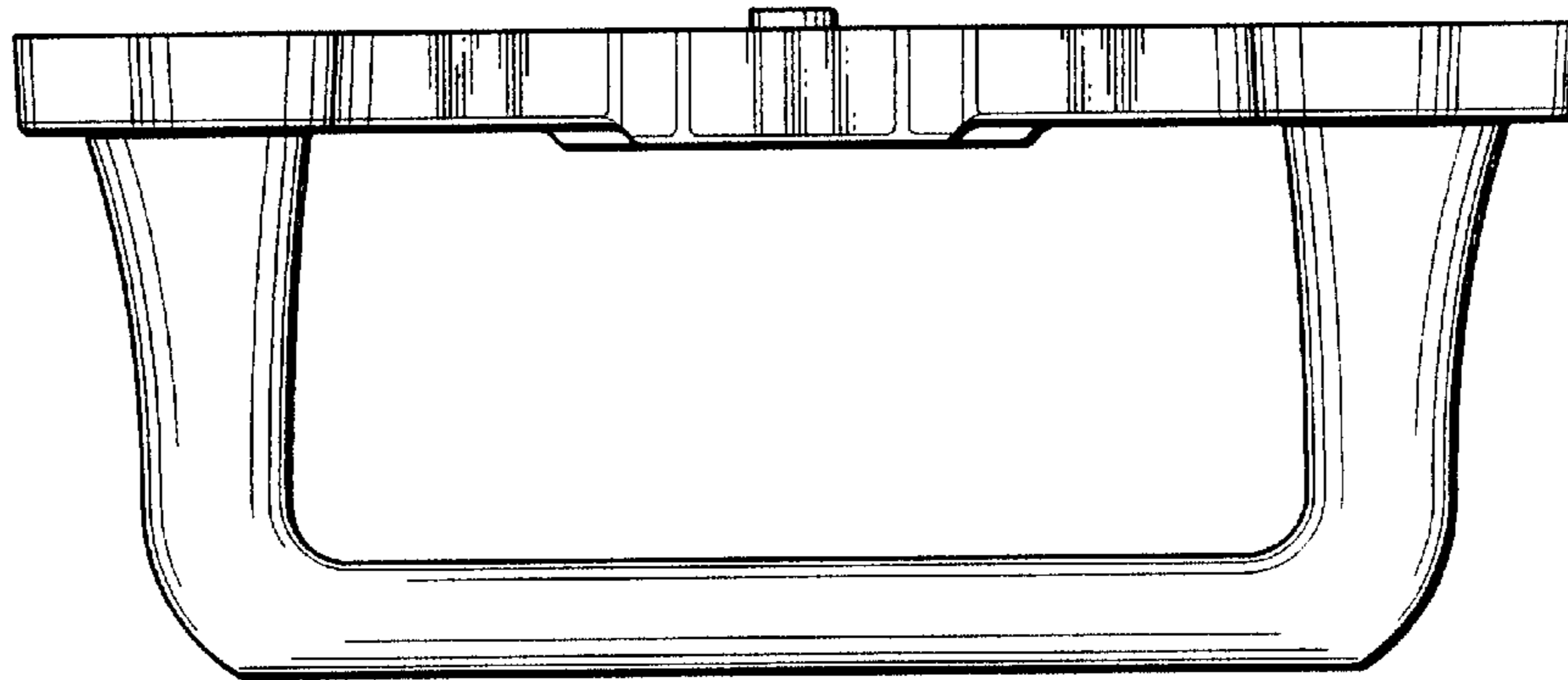

FIG. 3

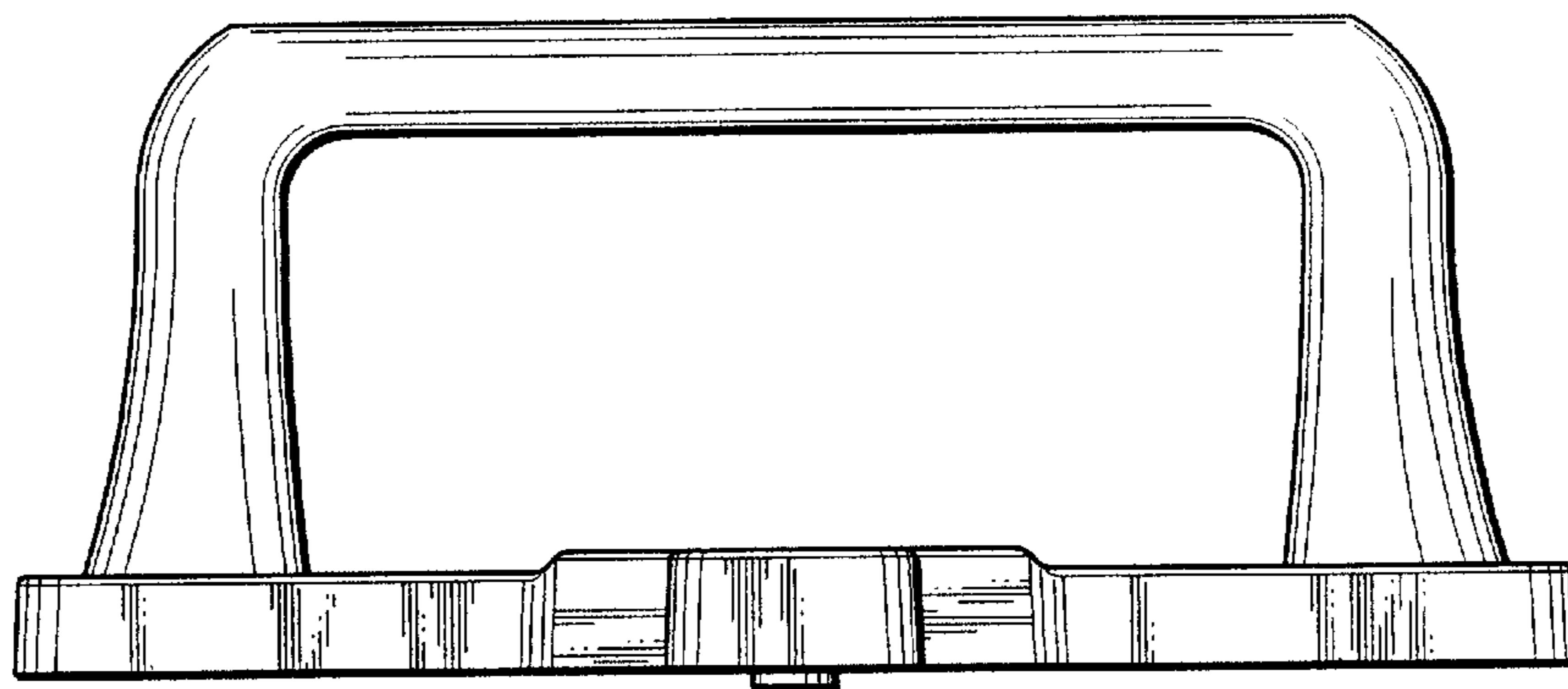

FIG. 4

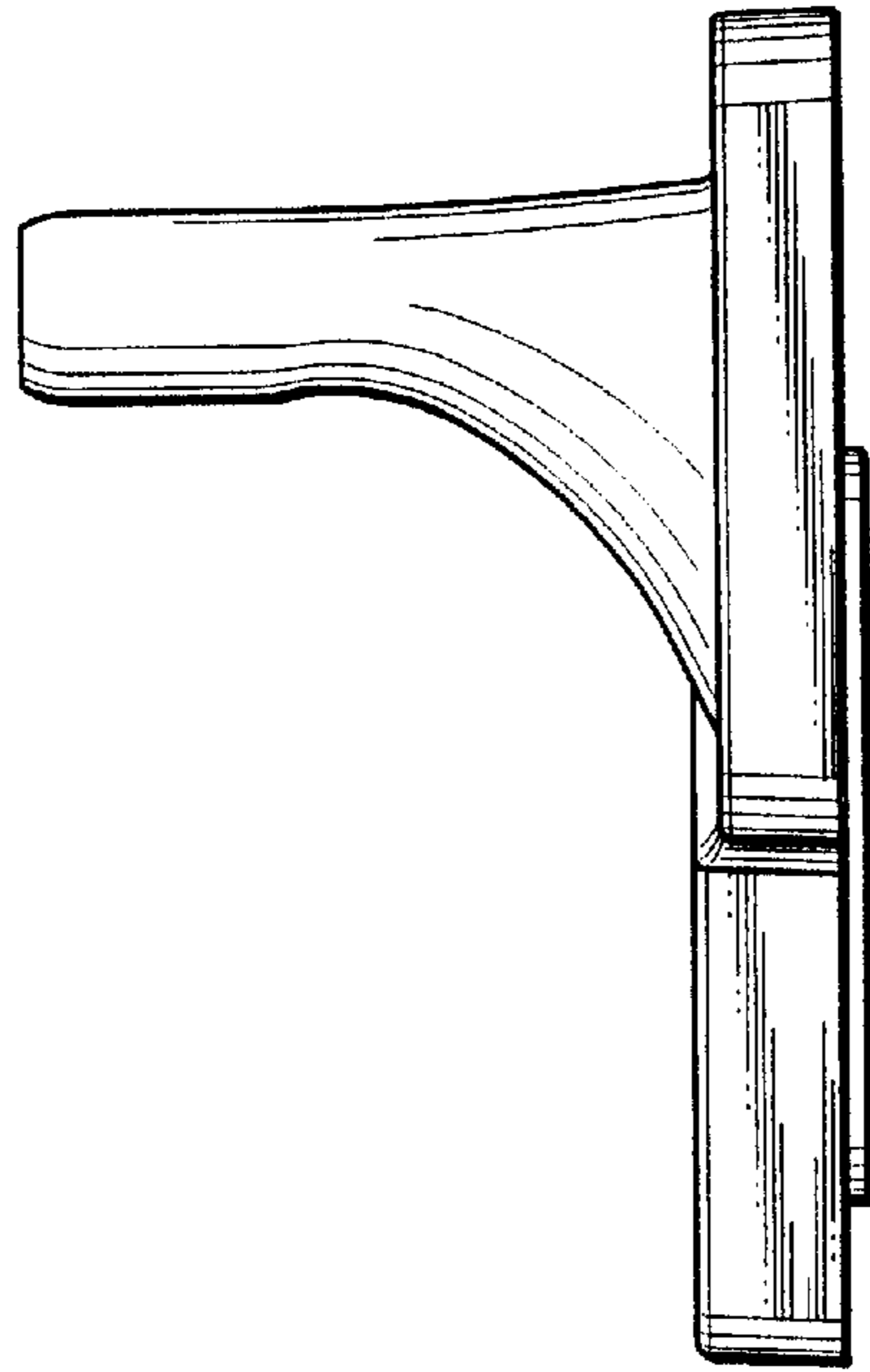

FIG. 5

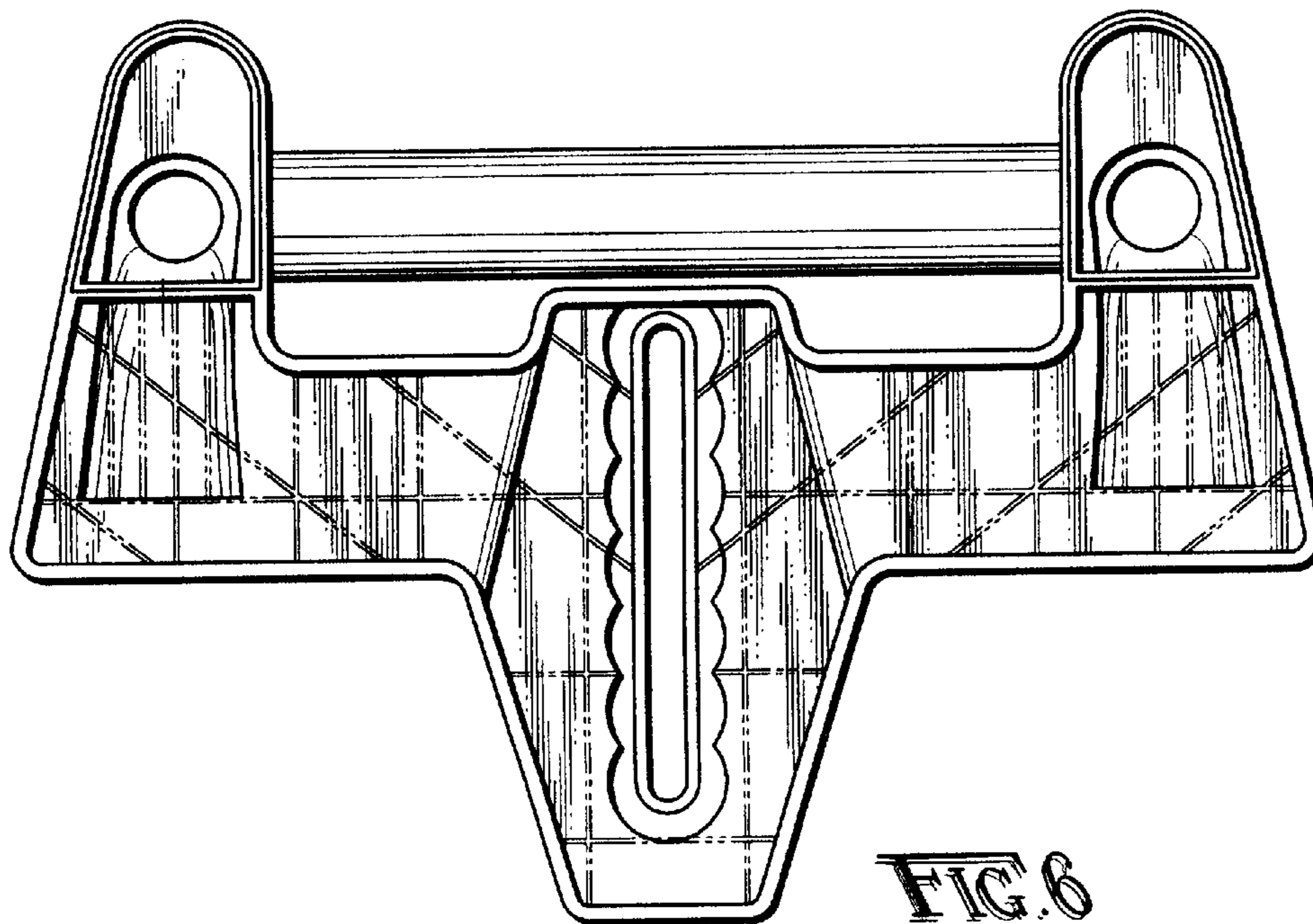

FIG. 6

