



US00D542197S

(12) **United States Design Patent**
Carlini

(10) **Patent No.:** **US D542,197 S**

(45) **Date of Patent:** **** May 8, 2007**

(54) **HANDLEBAR**

(76) Inventor: **Tony J. Carlini**, 5308 Seashore Dr.,
Apt. B, Newport Beach, CA (US)
92663

(**) Term: **14 Years**

(21) Appl. No.: **29/243,096**

(22) Filed: **Nov. 17, 2005**

(51) **LOC (8) Cl.** **12-16**

(52) **U.S. Cl.** **D12/178**

(58) **Field of Classification Search** D12/110-113,
D12/178; 74/551.1, 551.2, 551.3, 551.4,
74/551.5, 551.6, 551.7, 551.8, 551.9; 280/274-280,
280/281.1, 288.1-288.4; 180/219, 220
See application file for complete search history.

(56) **References Cited**

U.S. PATENT DOCUMENTS

3,331,617	A	*	7/1967	Jacoby	280/279
3,477,741	A	*	11/1969	Ross	280/279
D224,696	S	*	8/1972	Pawsat et al.	D12/178
D328,266	S	*	7/1992	Cummings	D12/112
D342,475	S	*	12/1993	Haro	D12/178
D415,084	S	*	10/1999	Clarkson	D12/178
D502,673	S	*	3/2005	Schlick	D12/111

OTHER PUBLICATIONS

Biker's Choice 2000 Handbook, Handlebar Dimension Chart at top of p. 417 and handlebars on the remainder of p. 417.*

Custom Chrome® Chrome Specialities® 2003, Ape Hanger Handlebars product Nos. 110000, 110005, and 110001 on p. 4.46.*

Drag Specialties 2002 FatBook, Arlen Ness 1.25" Fatness Bars product No. DS-300562 on p. 489.*

* cited by examiner

Primary Examiner—Alan P. Douglas

Assistant Examiner—Linda Brooks

(74) *Attorney, Agent, or Firm*—The Eclipse Group LLP

(57) **CLAIM**

The ornamental design for a handlebar, as shown and described.

DESCRIPTION

FIG. 1 is a front elevation view of a handlebar.

FIG. 2 is a rear perspective view of the handlebar of FIG. 1.

FIG. 3 is a front perspective view of the handlebar of FIG. 1.

FIG. 4 is a right side elevation view of the handlebar of FIG. 1.

FIG. 5 is a left side elevation view of the handlebar of FIG. 1.

FIG. 6 is a top view of the handlebar of FIG. 1; and,

FIG. 7 is a bottom view of the handlebar of FIG. 1.

1 Claim, 3 Drawing Sheets

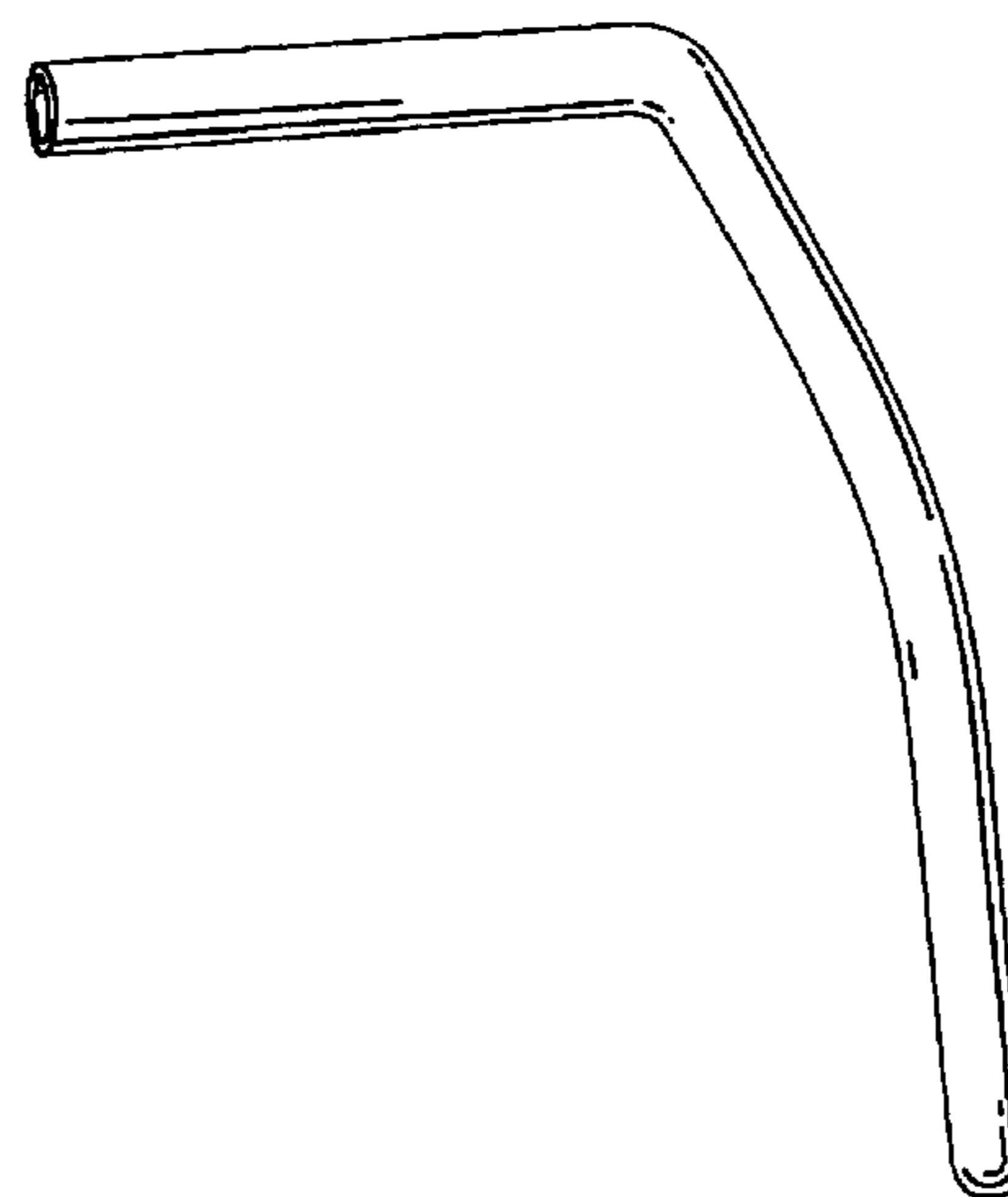
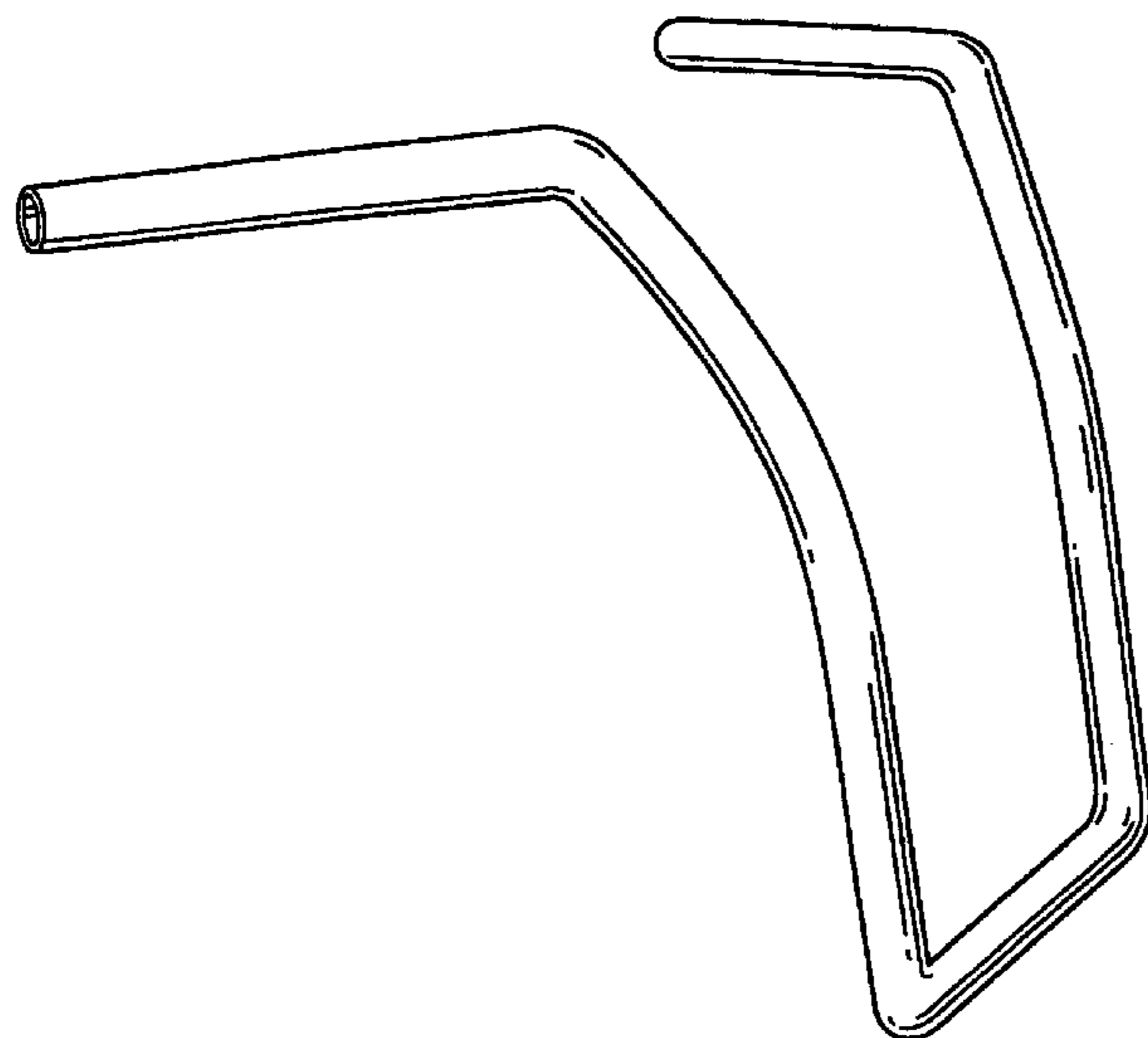

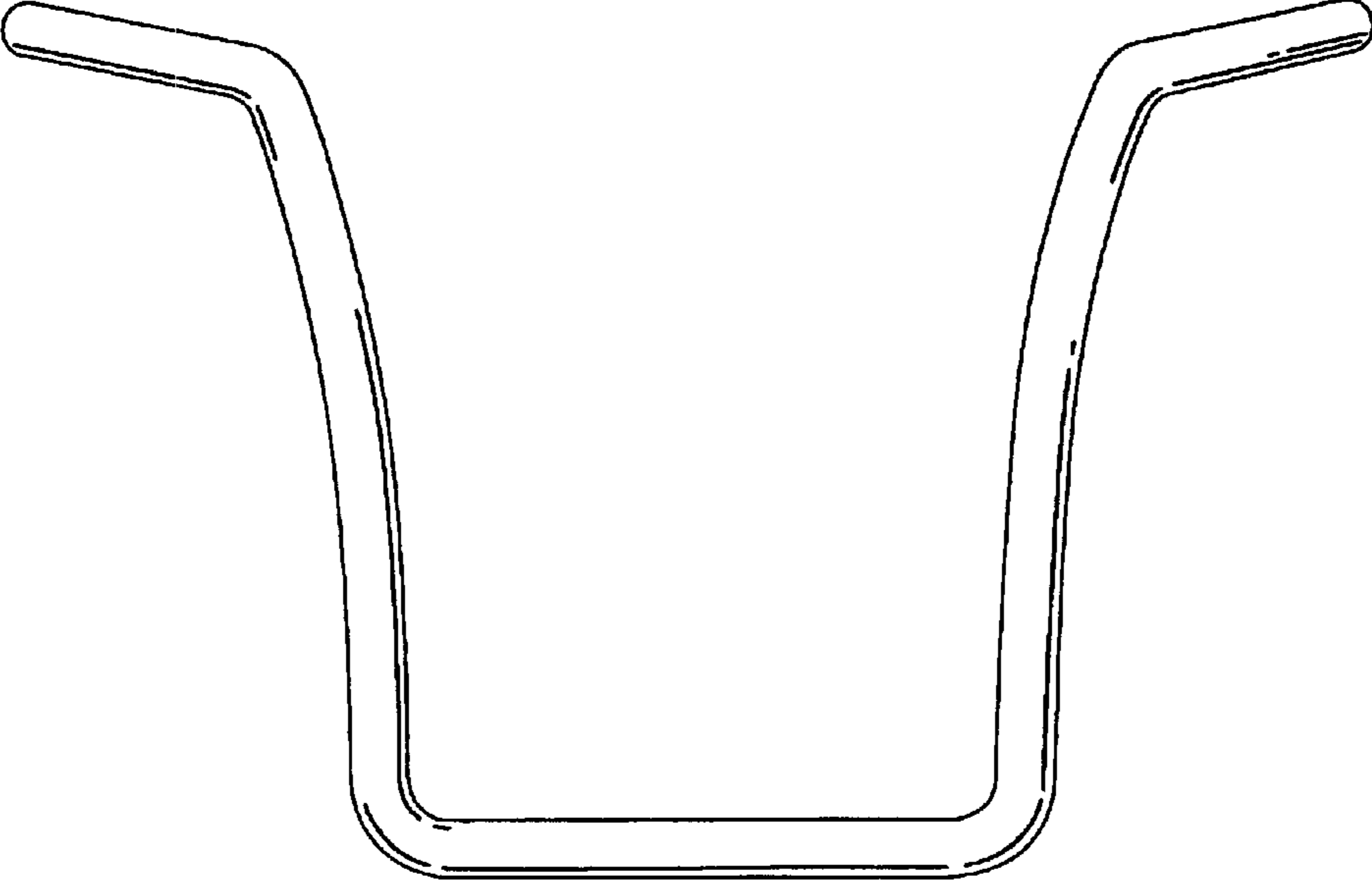

Fig. 1

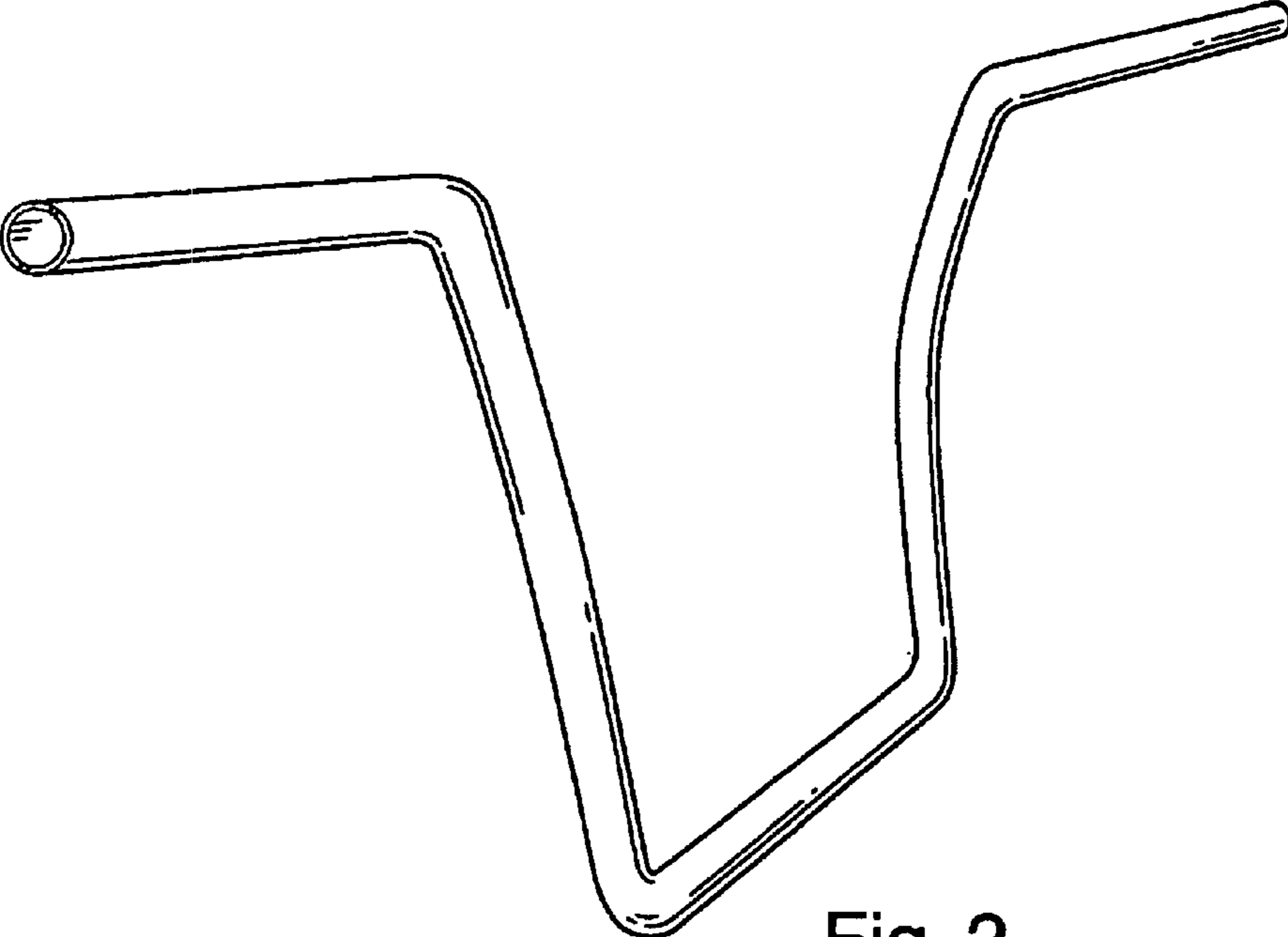

Fig. 2

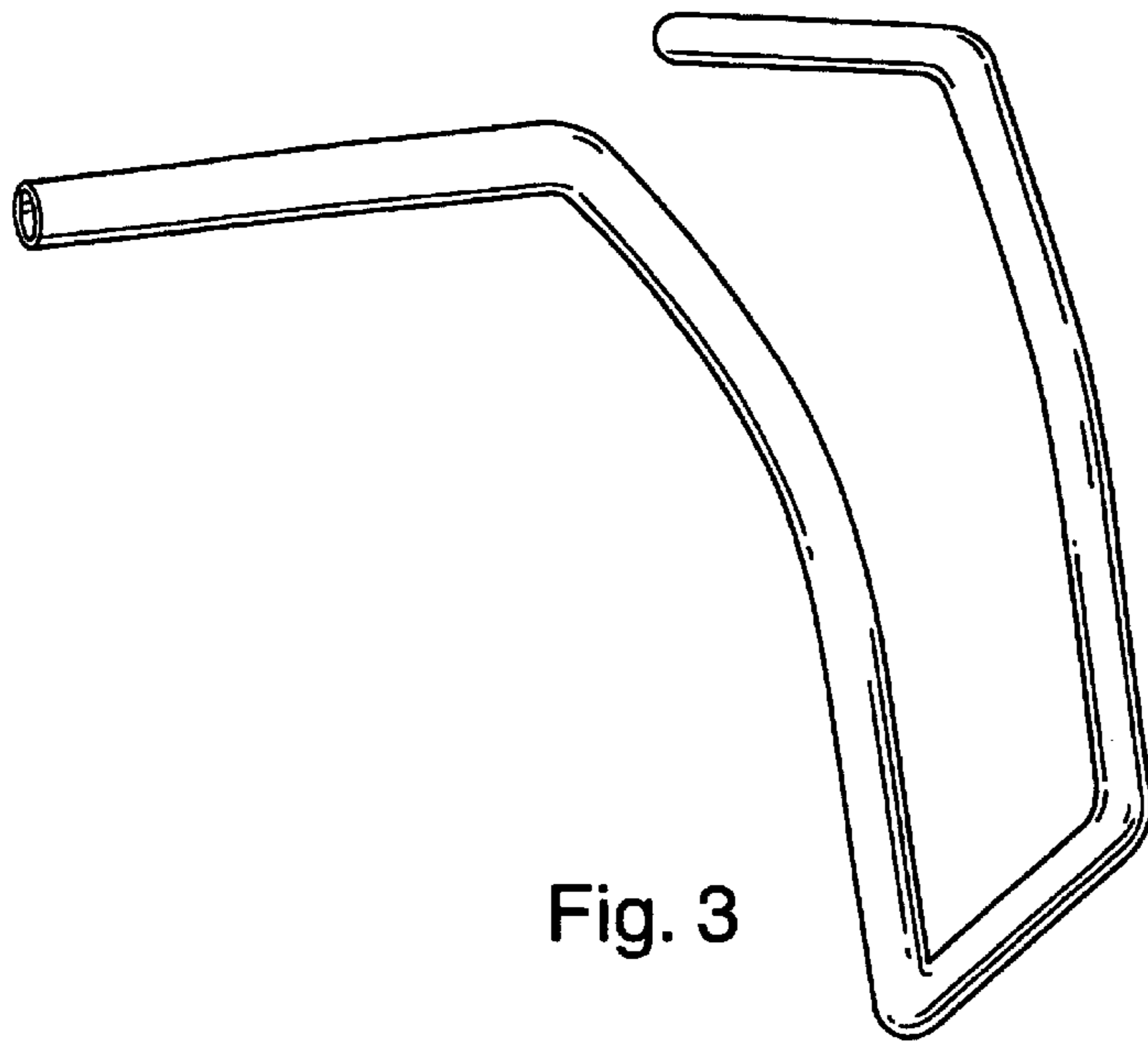

Fig. 3

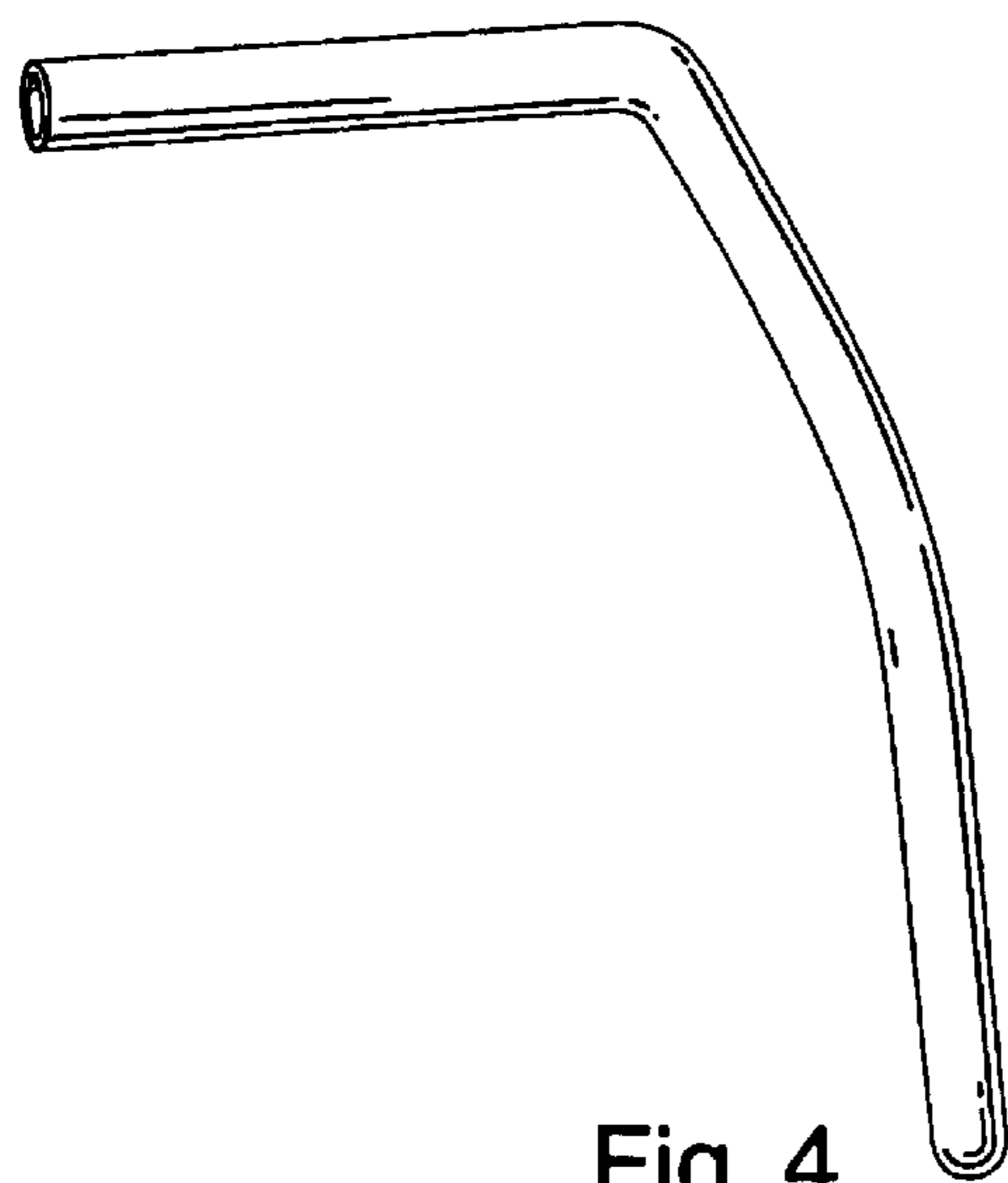

Fig. 4

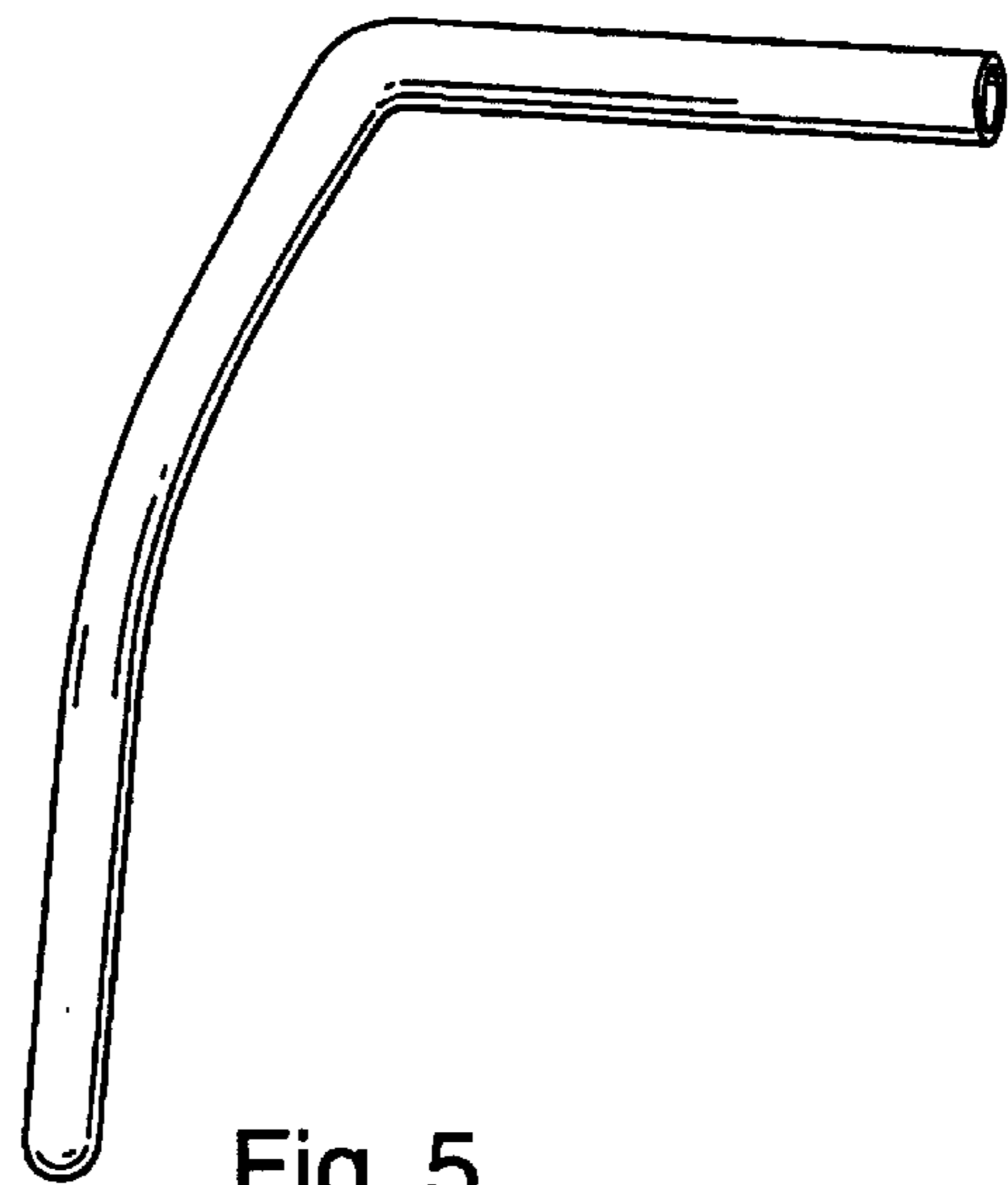

Fig. 5

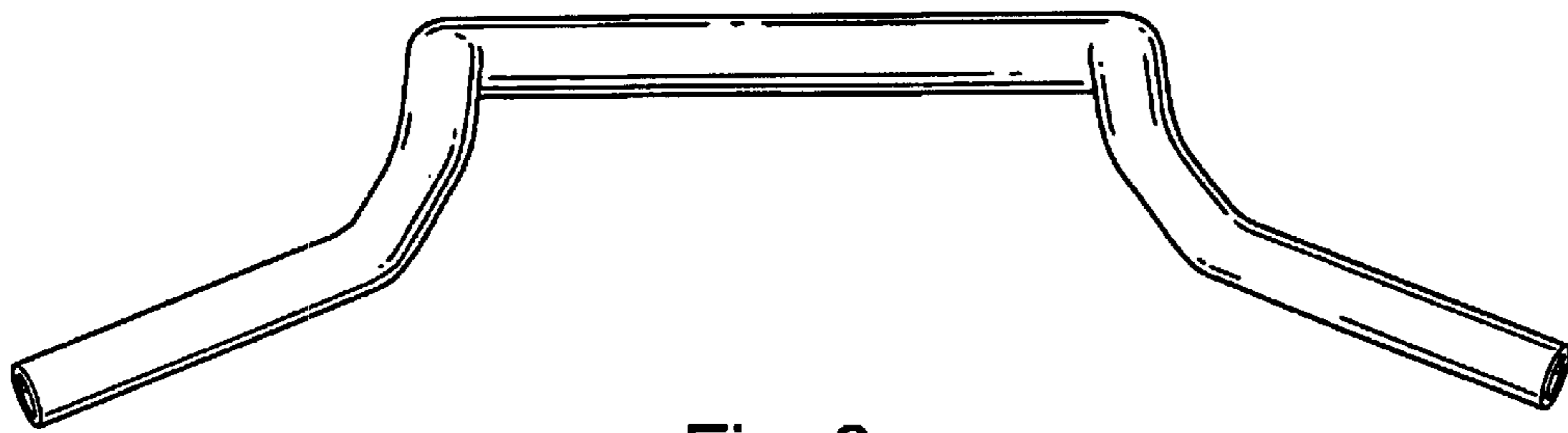

Fig. 6

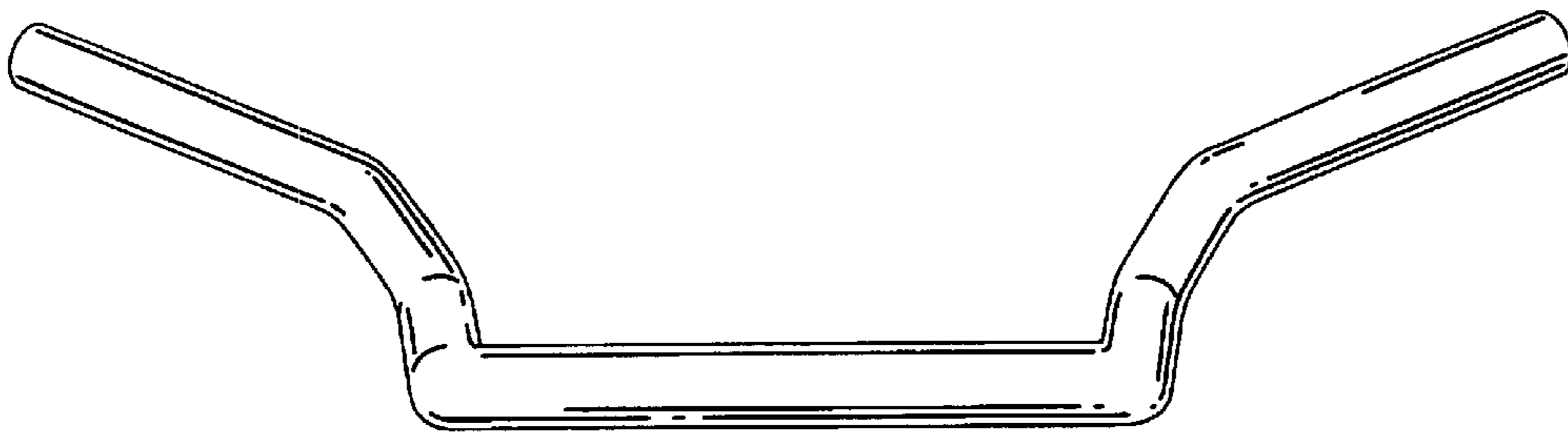

Fig. 7