



US00D542190S

(12) **United States Design Patent**
Chatigny

(10) **Patent No.:** **US D542,190 S**

(45) **Date of Patent:** **** May 8, 2007**

(54) **MOTORCYCLE RAIL**

(76) Inventor: **Albert R. Chatigny**, 87 Hadley Rd.,
Merrimack, MA (US) 01860

(**) Term: **14 Years**

(21) Appl. No.: **29/233,625**

(22) Filed: **Jul. 7, 2005**

(51) **LOC (8) Cl.** **12-11**

(52) **U.S. Cl.** **D12/114**

(58) **Field of Classification Search** D12/114,
D12/223, 407, 409, 410, 414, 190, 110; 280/202,
280/288.4, 304.3; 224/413, 441, 428-439,
224/42.11, 924

See application file for complete search history.

(56) **References Cited**

U.S. PATENT DOCUMENTS

624,669 A * 5/1899 Moore 224/432
D280,310 S * 8/1985 Preisler et al. D12/407
5,762,249 A * 6/1998 Hann 224/430

6,817,501 B1 * 11/2004 Rogers et al. 224/413

* cited by examiner

Primary Examiner—Alan P. Douglas

Assistant Examiner—Linda Brooks

(74) *Attorney, Agent, or Firm*—Bourquo and Associates

(57) **CLAIM**

The ornamental design for a motorcycle rail, as shown and described.

DESCRIPTION

FIG. (1) is a side view of motorcycle rail shown in combination with a motorcycle having a side bag;

FIG. (2) is a top perspective view of the motorcycle rail shown installed on a side bag;

FIG. (3) is a top, end perspective view of the motorcycle rail;

FIG. (4) is a top plan view thereof;

FIG. (5) is a side plan view thereof; and,

FIG. (6) is an end plan view thereof.

The motorcycle and side bag shown in broken lines form no part of the claimed design thereof.

1 Claim, 5 Drawing Sheets

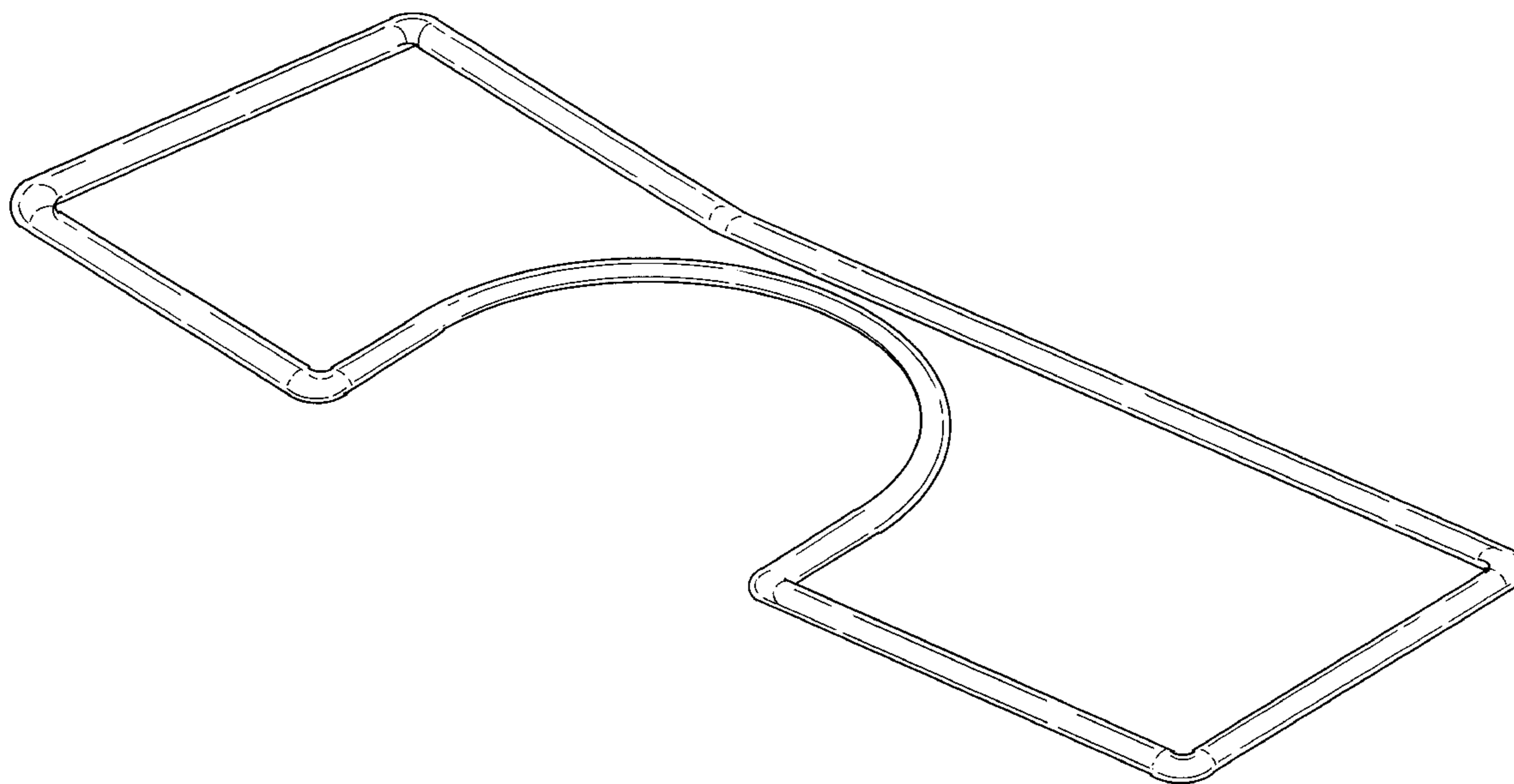

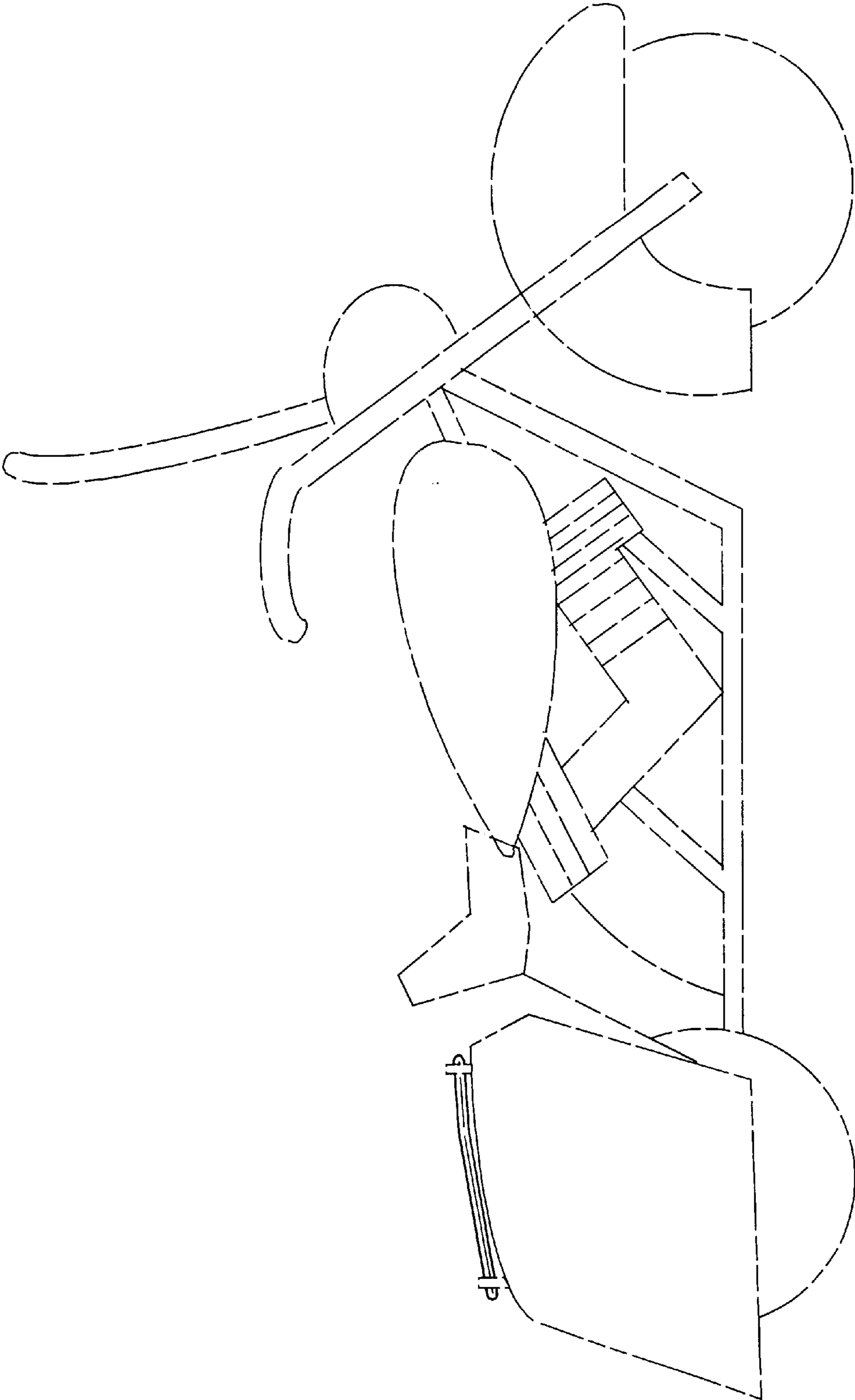

FIG. 1

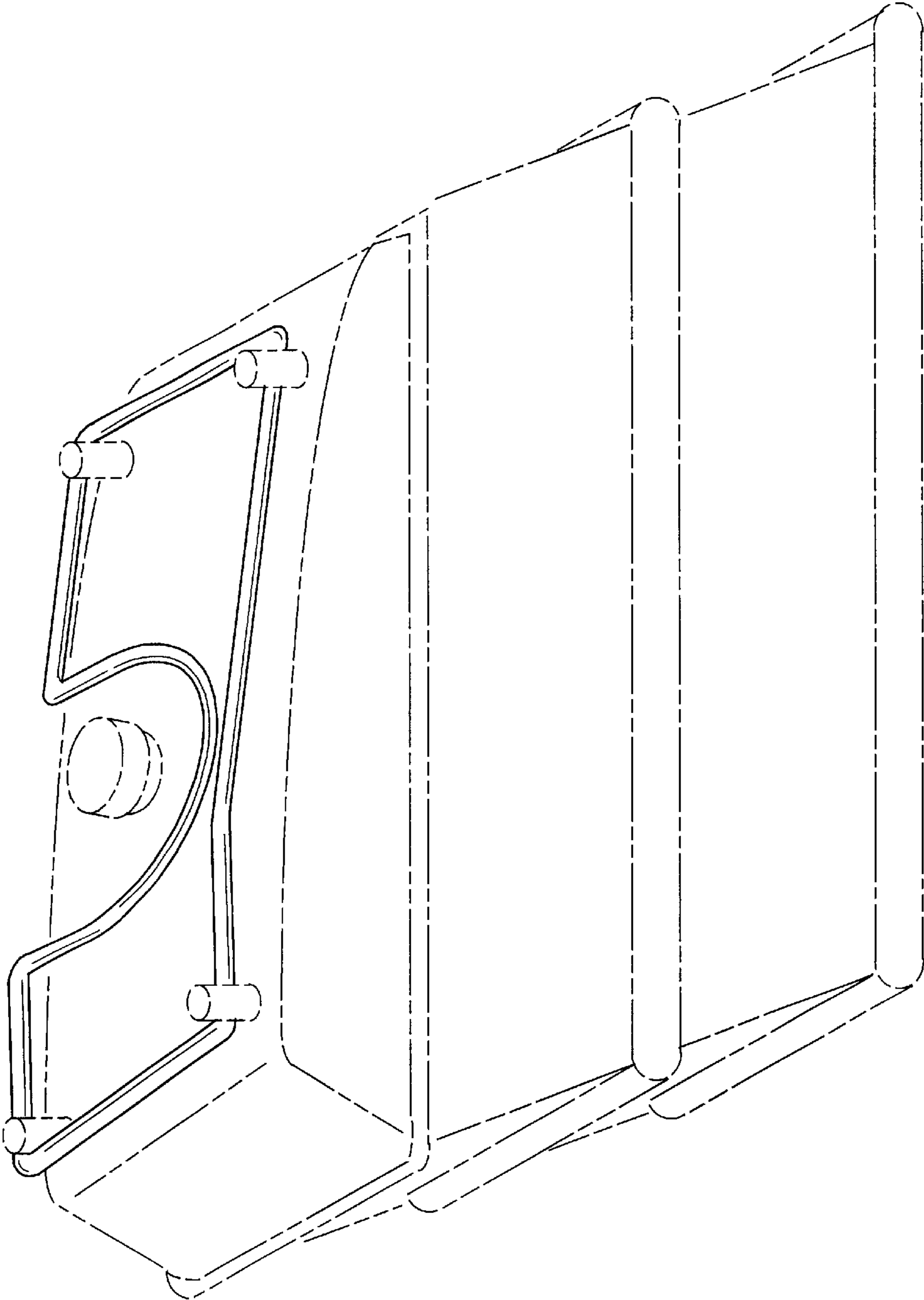

FIG. 2

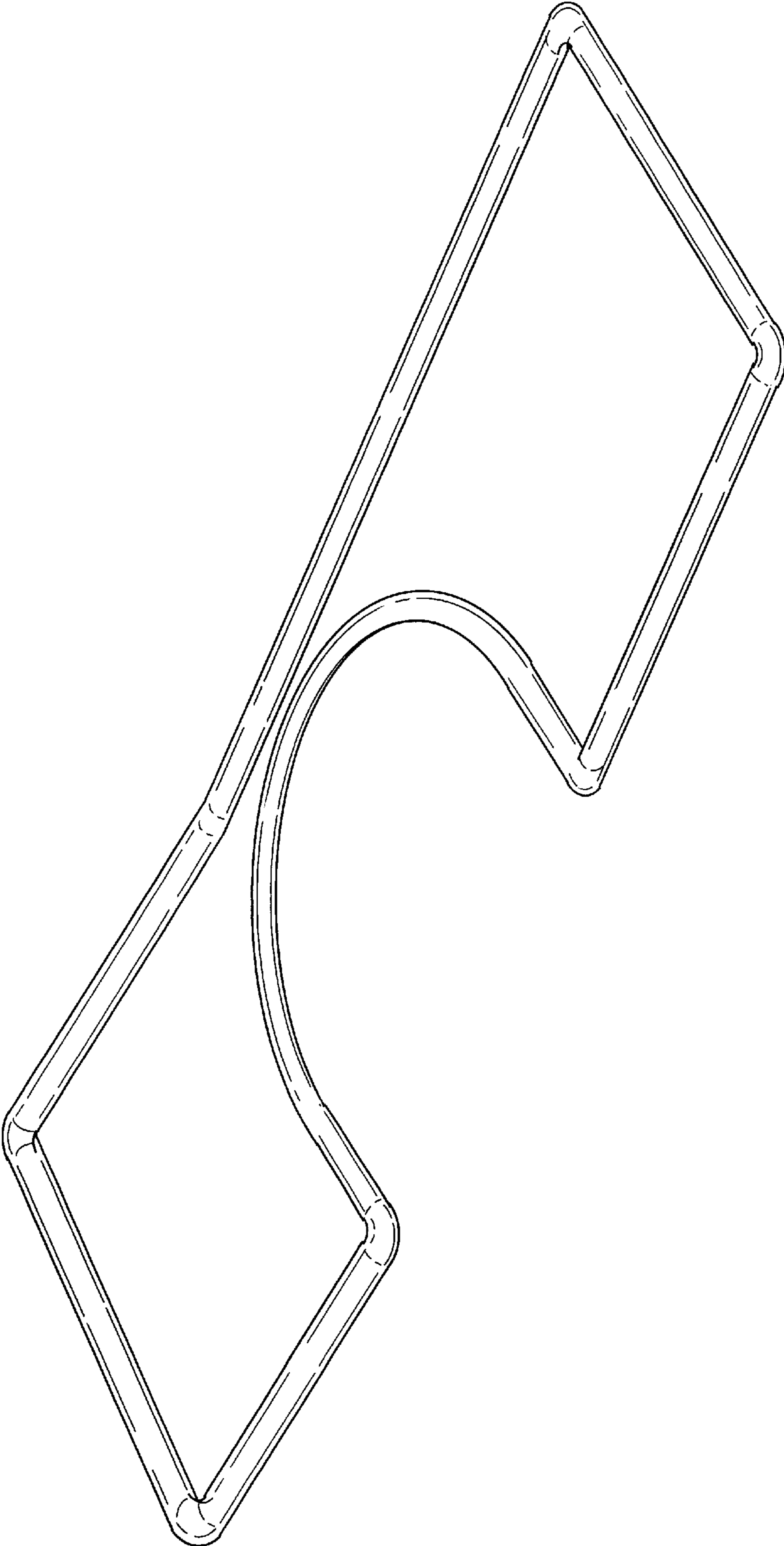

FIG. 3

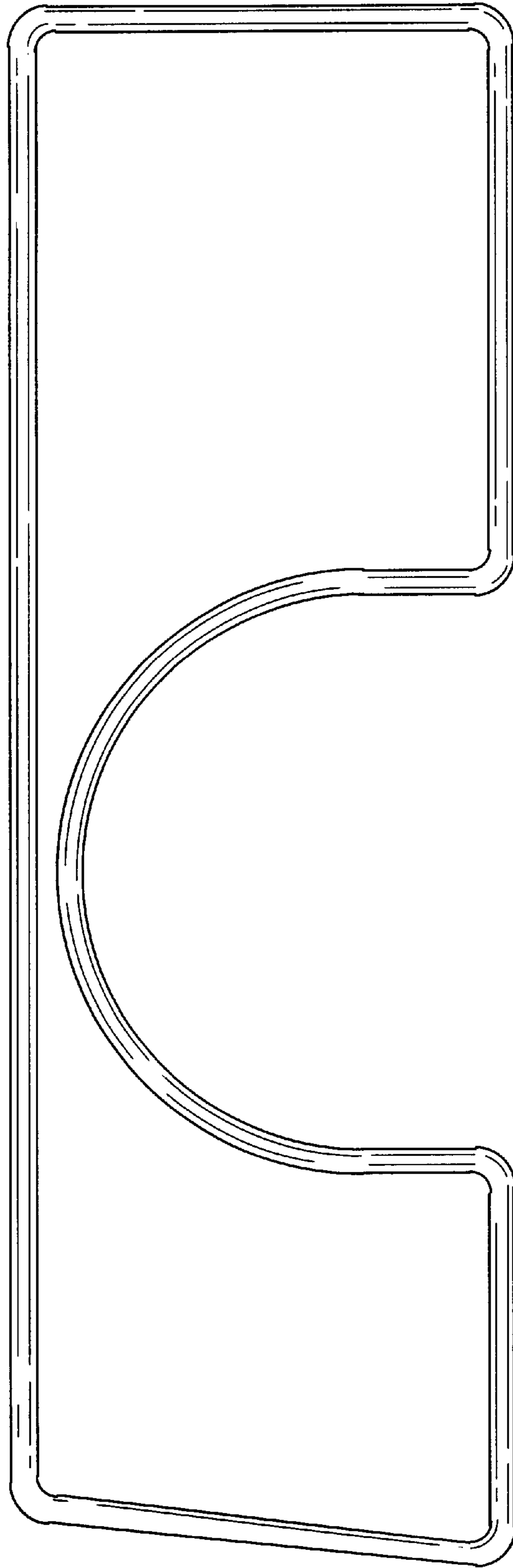

FIG. 4

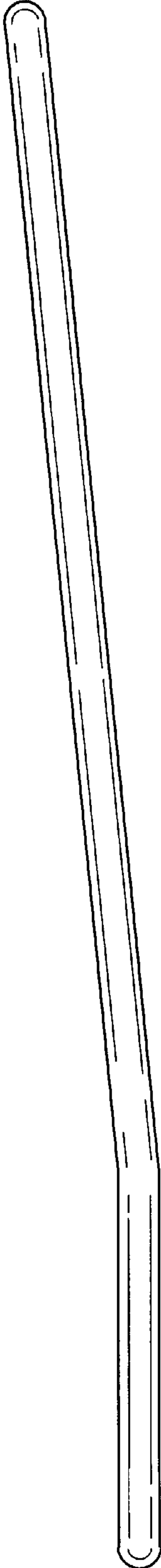

FIG. 5

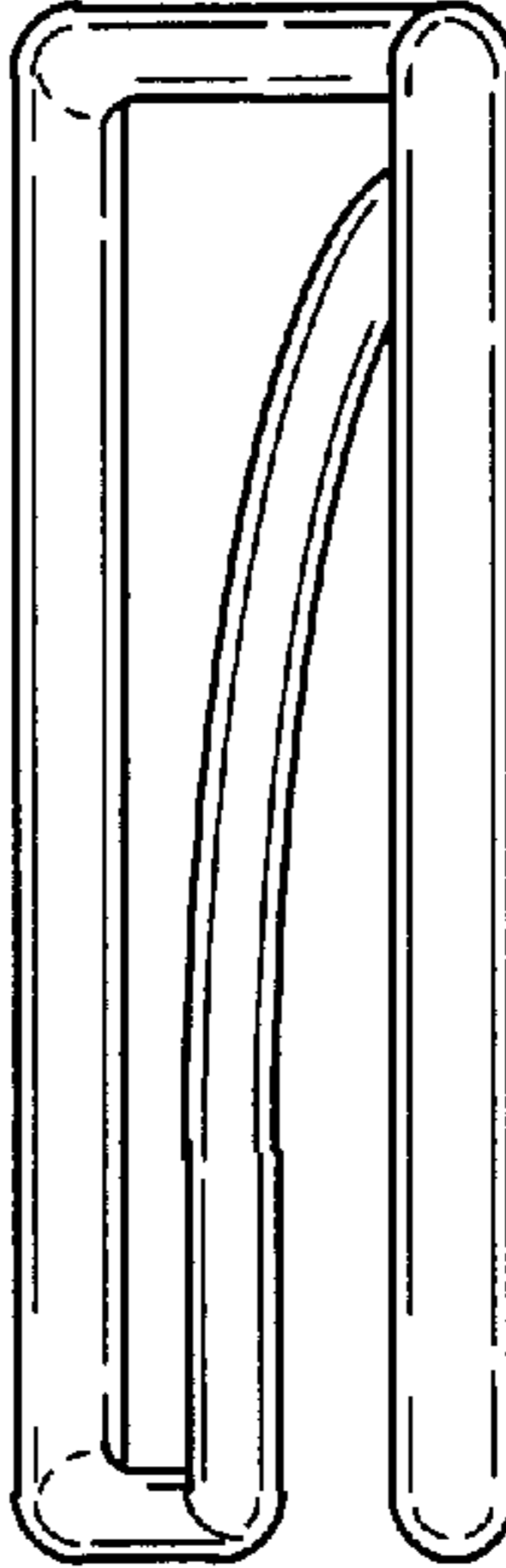

FIG. 6