

US00D541719S

(12) **United States Design Patent**  
**McChesney et al.**

(10) **Patent No.:** **US D541,719 S**

(45) **Date of Patent:** **\*\* May 1, 2007**

(54) **AUTOMOTIVE TAILGATE**

D494,910 S \* 8/2004 Metros et al. .... D12/196  
D508,440 S \* 8/2005 Hall et al. .... D12/98

(75) Inventors: **Mark McChesney**, Saline, MI (US);  
**Richard Susack**, Belleville, MI (US);  
**Patrick Schiavone**, Birmingham, MI  
(US); **Chelsia Lau**, Ann Arbor, MI  
(US)

**OTHER PUBLICATIONS**

<http://www.fordvehicles.com/suvs/explorersporttrac/>, Ford  
Vehicles: 2005 Ford Explorer Sport Trac—See pricing  
details, SUV options, packages and more, 16 pages.

(73) Assignee: **Ford Global Technologies, LLC**,  
Dearborn, MI (US)

\* cited by examiner

(\*\*) Term: **14 Years**

*Primary Examiner*—Melody N. Brown

(74) *Attorney, Agent, or Firm*—Frank A. MacKenzie;  
Brooks Kushman P.C.

(21) Appl. No.: **29/225,429**

(57) **CLAIM**

(22) Filed: **Mar. 15, 2005**

The ornamental design for an automotive tailgate, as shown  
and described.

(51) **LOC (8) Cl.** ..... **12-16**

(52) **U.S. Cl.** ..... **D12/196**

(58) **Field of Classification Search** ..... D12/196,  
D12/98, 93; 296/57.1, 3, 26, 50, 37.1, 37.6  
See application file for complete search history.

**DESCRIPTION**

FIG. 1 is a perspective view of an automotive tailgate; and,  
FIG. 2 is a front end perspective view of the automotive  
tailgate of FIG. 1.

(56) **References Cited**

The rear of the design is not being claimed as part of the  
design.

**U.S. PATENT DOCUMENTS**

The broken lines are for illustrative purposes only and form  
no part of the claimed design.

D479,157 S \* 9/2003 Hayashi et al. .... D12/98

D481,339 S \* 10/2003 McClellan et al. .... D12/196

D494,521 S \* 8/2004 Metros et al. .... D12/196

**1 Claim, 1 Drawing Sheet**

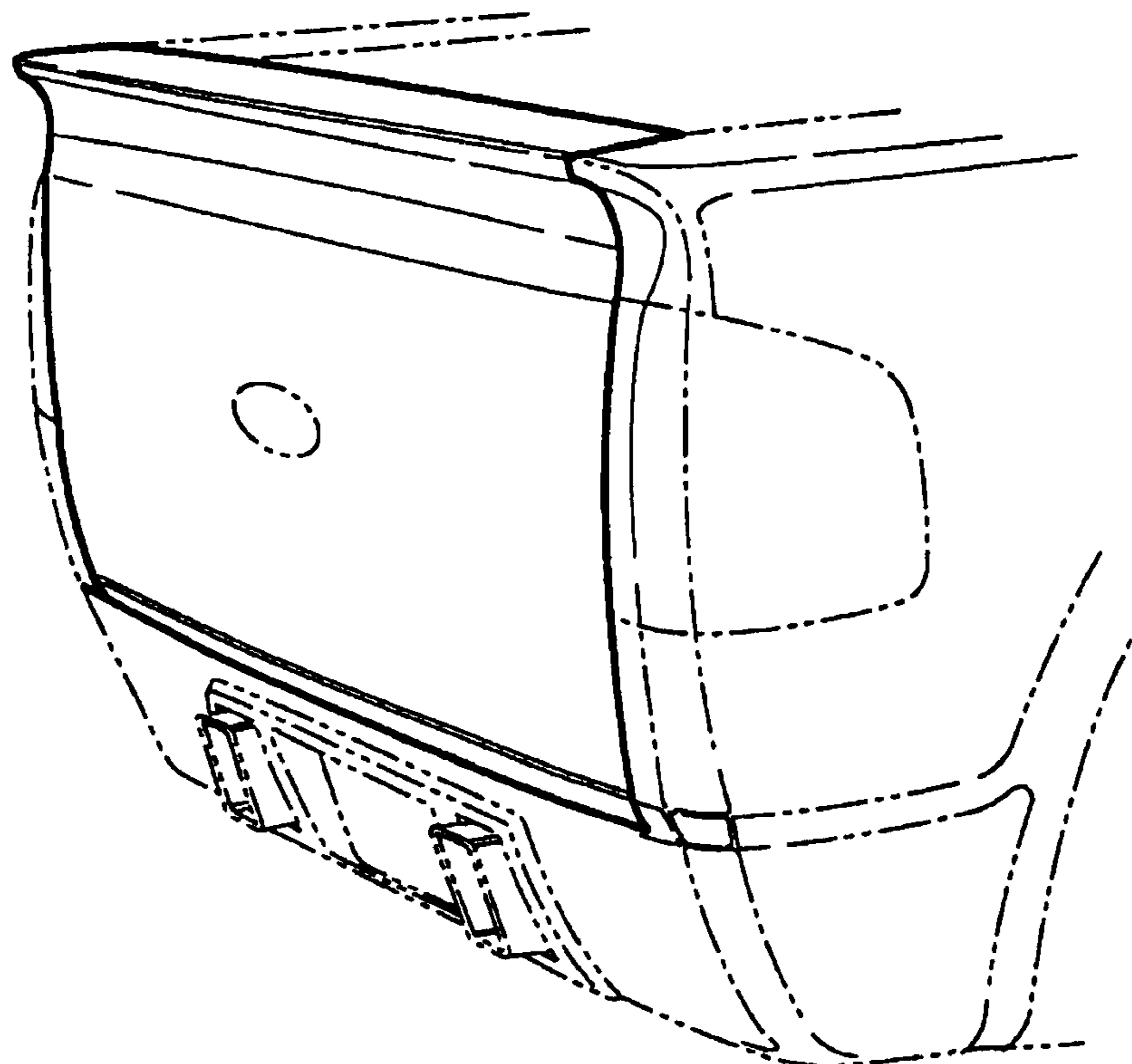

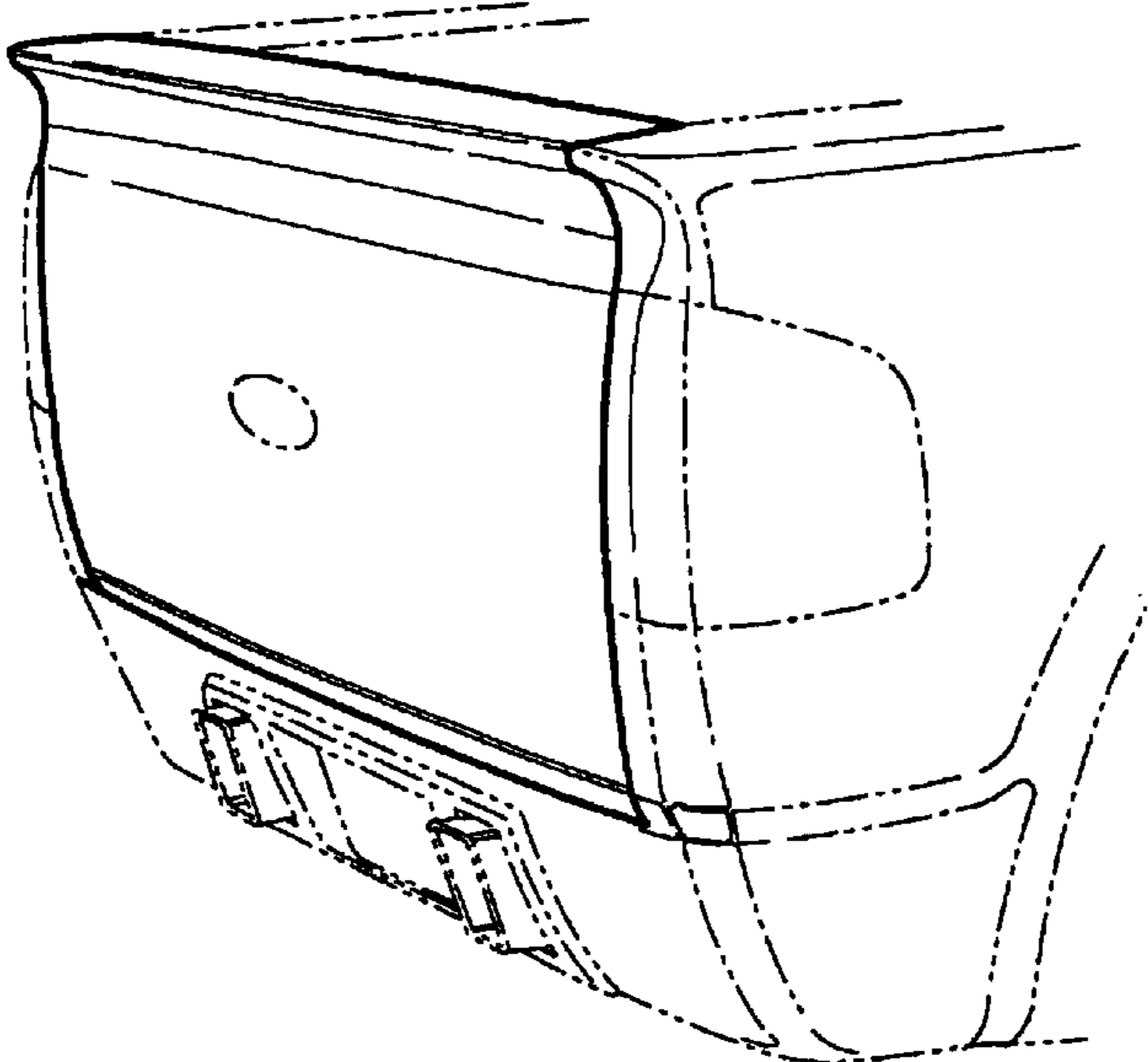

**FIG - 1**

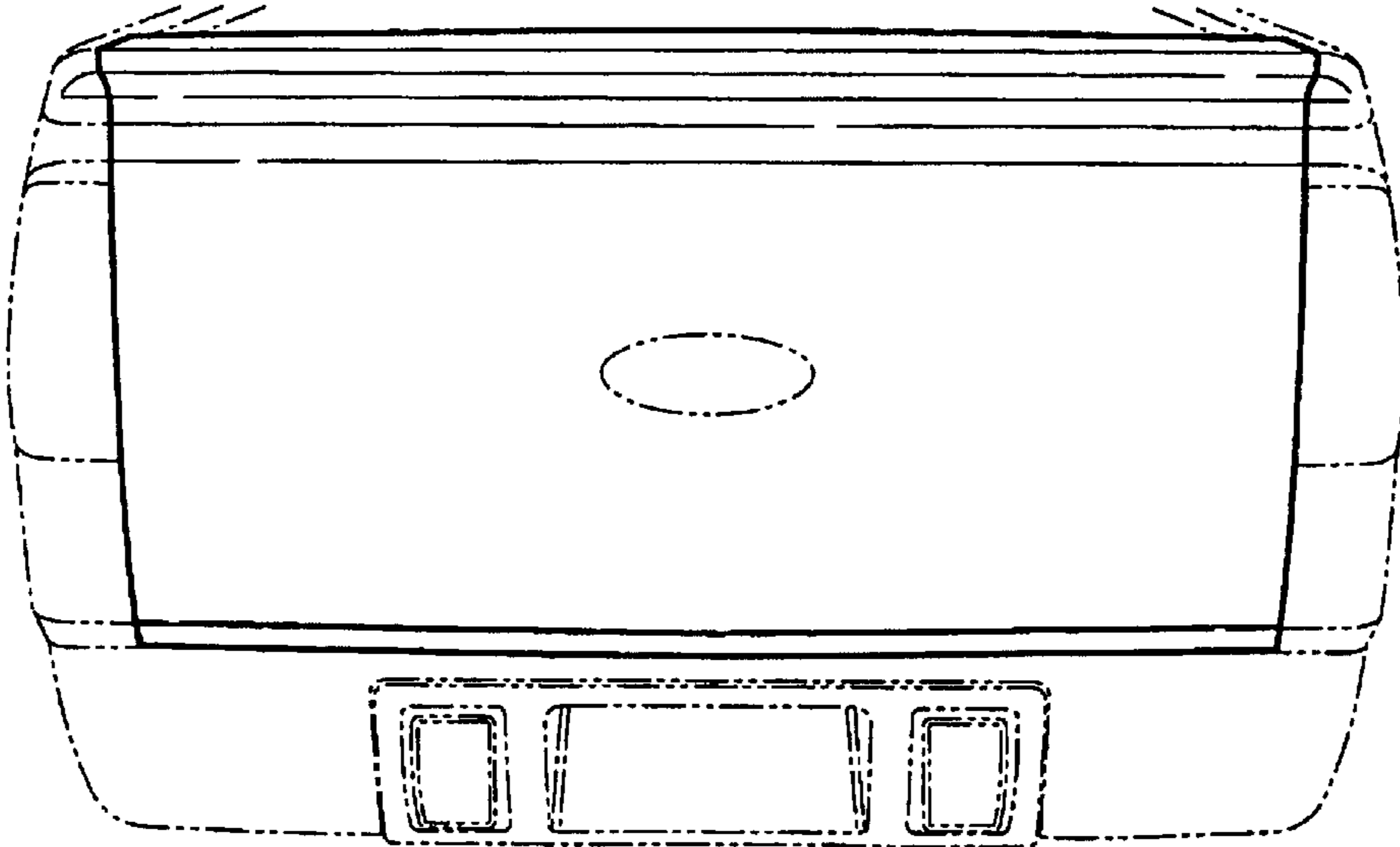

**FIG - 2**