

US00D541711S

(12) **United States Design Patent**
Golden et al.

(10) **Patent No.:** **US D541,711 S**

(45) **Date of Patent:** **** May 1, 2007**

(54) **AUTOMOBILE LOWER BUMPER**

(75) Inventors: **Edward Golden**, Pinckney, MI (US);
Darrell Behmer, Novi, MI (US);
Melvin Betancourt, Shelby Township,
MI (US); **Solomon Song**, Farmington
Hills, MI (US); **Shawn Wehrly**, Royal
Oak, MI (US)

(73) Assignee: **Ford Global Technologies, LLC**,
Dearborn, MI (US)

(**) Term: **14 Years**

(21) Appl. No.: **29/241,396**

(22) Filed: **Oct. 27, 2005**

(51) **LOC (8) Cl.** **12-16**

(52) **U.S. Cl.** **D12/169**

(58) **Field of Classification Search** D12/90-92,
D12/86, 169, 196; 296/180.1, 180.2; 293/102,
293/113, 115, 117, 120

See application file for complete search history.

(56) **References Cited**

U.S. PATENT DOCUMENTS

D494,514 S	*	8/2004	Pfeiffer	D12/163
D494,897 S	*	8/2004	Pfeiffer	D12/163
D516,956 S	*	3/2006	Bucci et al.	D12/91
D523,791 S	*	6/2006	Pfeiffer	D12/163
D525,920 S	*	8/2006	Toyoda	D12/163

OTHER PUBLICATIONS

Car And Driver.com, Auto Show: *2004 North American International Auto Show*, Jan. 2004, http://www.caranddriver.com/article.asp?intAsvPageCurrent=9§ion_id=31&article_id=7671.

Automotive News, Lincoln: *Division searches for styling product mix*, p. 39, Jan. 5, 2004.

LA Car.com, Turning Up The Heat: *Lincoln Aviator*, Jan. 10, 2004 <http://lacar.com/modules.php?name=News&file=print&sid=185>.

AIC Autosite Online, *Cool Concept: Lincoln Aviator Concept*, Apr. 19, 2004 <http://www.aicautosite.com/Previews/concept-lincoln-aviator.asp>.

Automobile Magazine, *50 Sneak Peaks—Lincoln Aviator*, p. 65, May 2004.

Automobile News Online, Future Products—*FORD: Going global: Ford borrows platforms from Europe, Japan*, Aug. 2, 2004 <http://www.autonews.com/article.cms?articleId=49216>.

Popular Mechanics Online, *Spy Reports—Detroit, Asia and Europe*, Feb. 2005 http://www.popularmechanics.com/automotive/spy_reports/1372741.html.

Trailer Life, *Downsizing Lincoln*, vol: 65, Issue 2, ISSN: 00410780, p. 18, Feb. 1, 2005.

The Detroit News, *2007 Lincoln Aviator*, p. 3, Feb. 9, 2005. AutoWeek.com, *2007 Lincoln Aviator*, Feb. 16, 2005 <http://forums.autoweek.com/thread.jspa?forumID=31&threadID=12757&messageID=250387>.

TheCarConnection.com, *Future Cars: Ford/PAG/Mazda*, May 16, 2005 http://www.thecarconnection.com/Shoppers/Future_Cars/Ford.S283.A8367.html.

Automobile Magazine, *2006 SUV Sneak Preview*, Publication Date: Unknown http://www.automobilemag.com/2006_sneak_preview/0503_sp_suv/index.html.

* cited by examiner

Primary Examiner—Melody N. Brown

(74) *Attorney, Agent, or Firm*—Fredrick Owens

(57) **CLAIM**

The ornamental design for an automobile lower bumper, as shown and described in FIGS. 1-5.

DESCRIPTION

FIG. 1 is a front perspective view of an automobile lower bumper attached to a vehicle, no part of the vehicle is claimed;

FIG. 2 is a perspective view of the automobile grille;

FIG. 3 is a front view of the automobile grille;

FIG. 4 is a top view of the automobile grille; and,

FIG. 5 is a left side view of the automobile grille (the right side view is a mirror of the left side view and is not shown).

The broken lines are for illustrative purposes only and form no part of the claimed design.

1 Claim, 5 Drawing Sheets

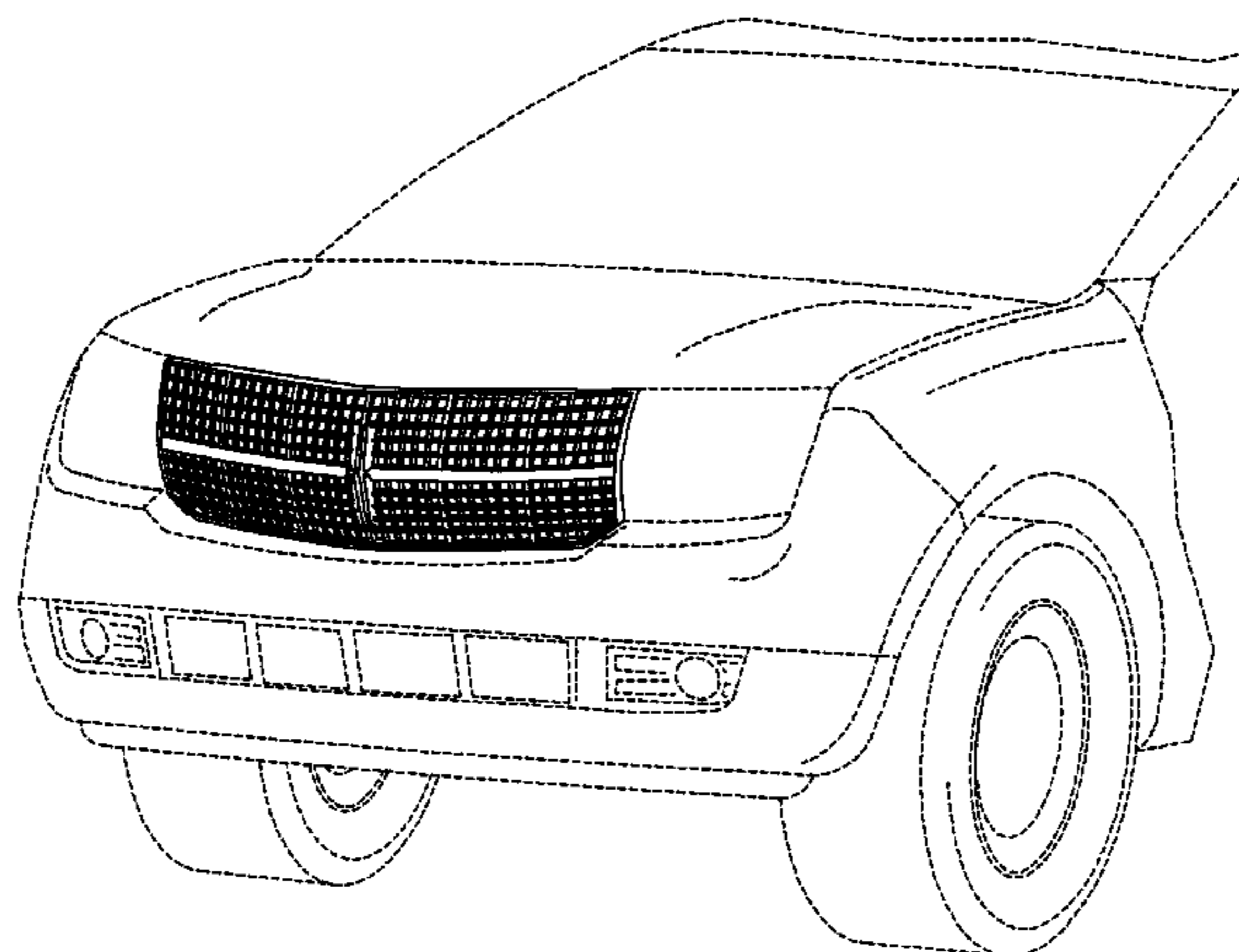

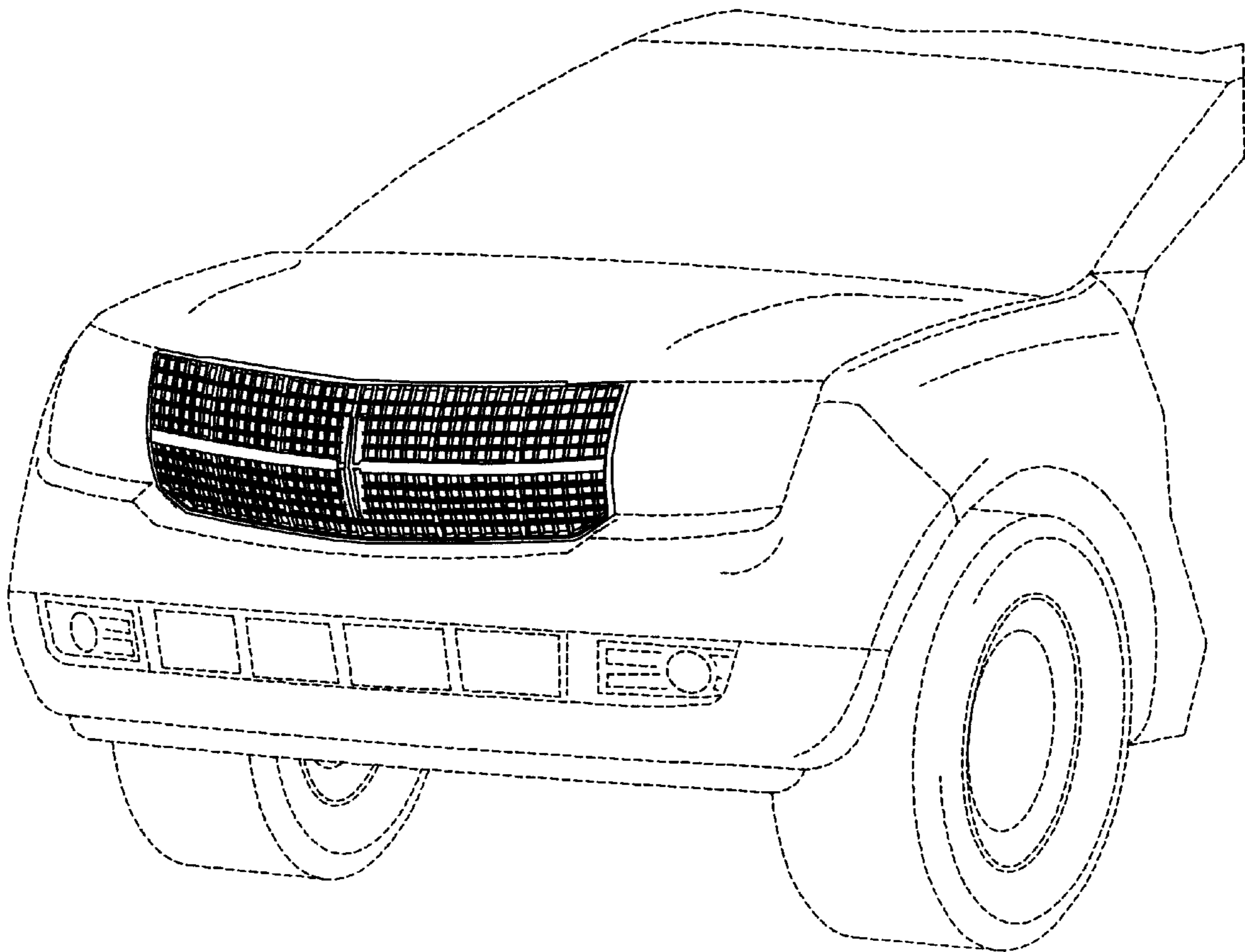

FIG - 1

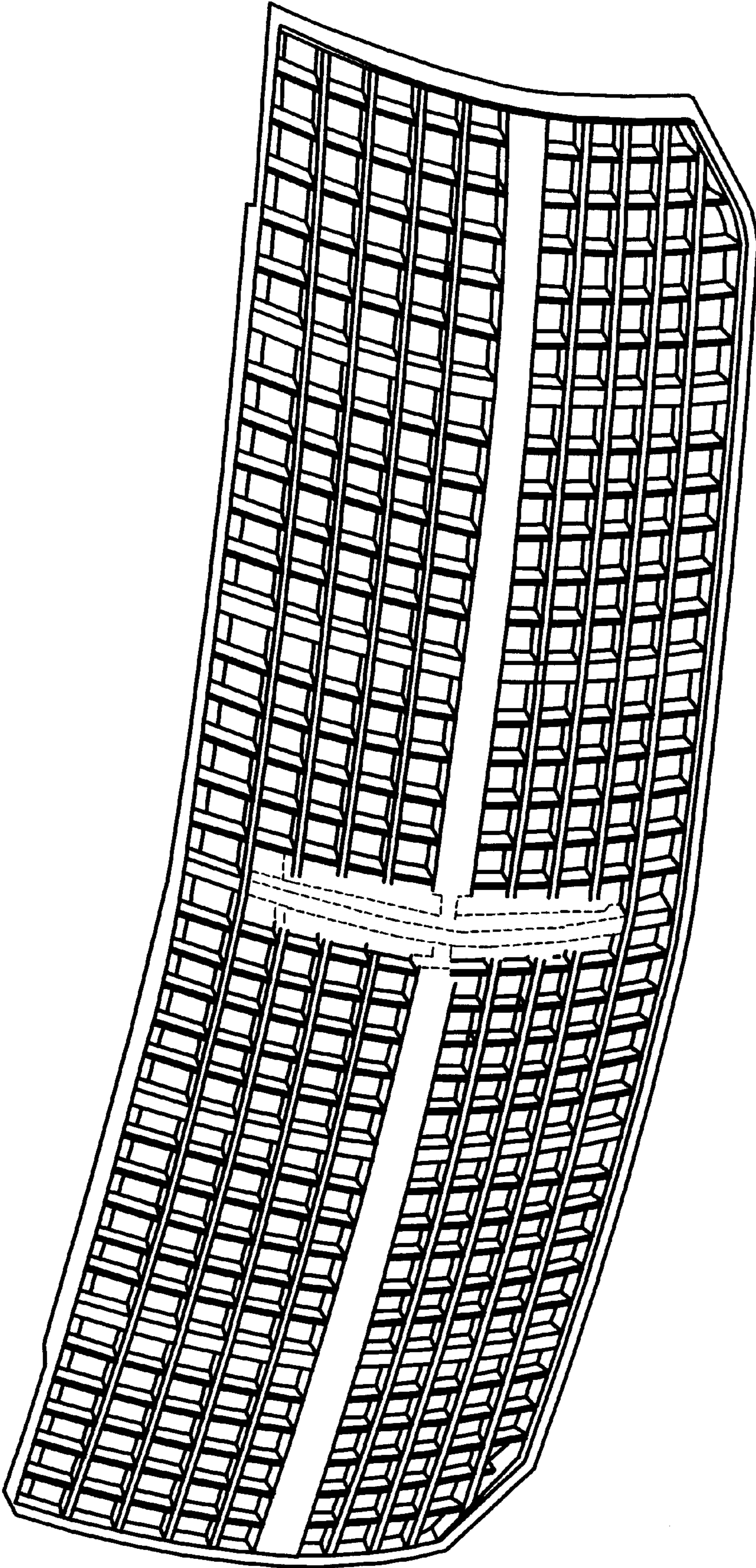

FIG - 2

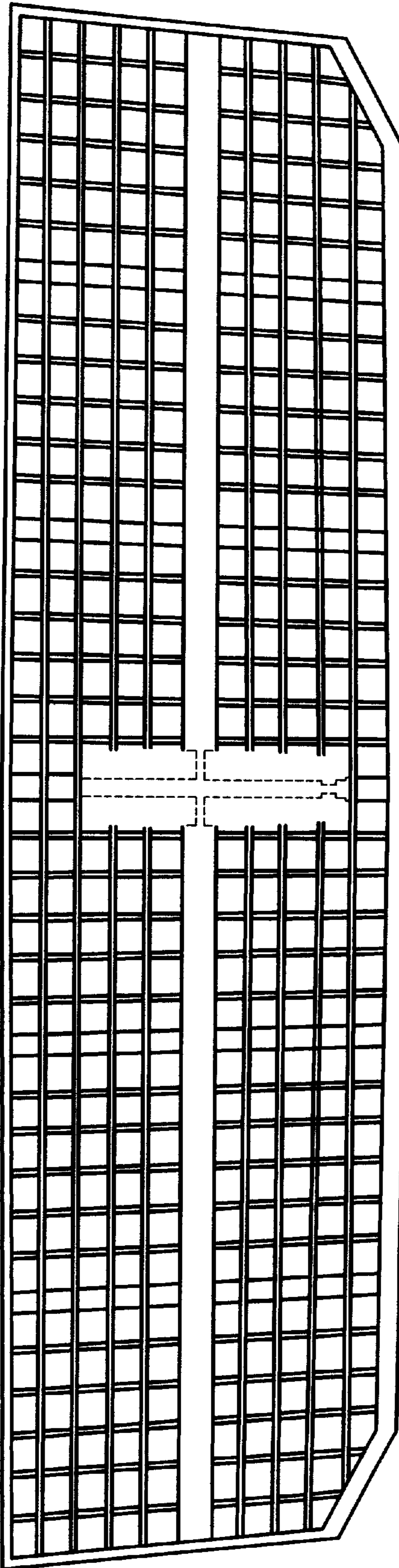

FIG - 3

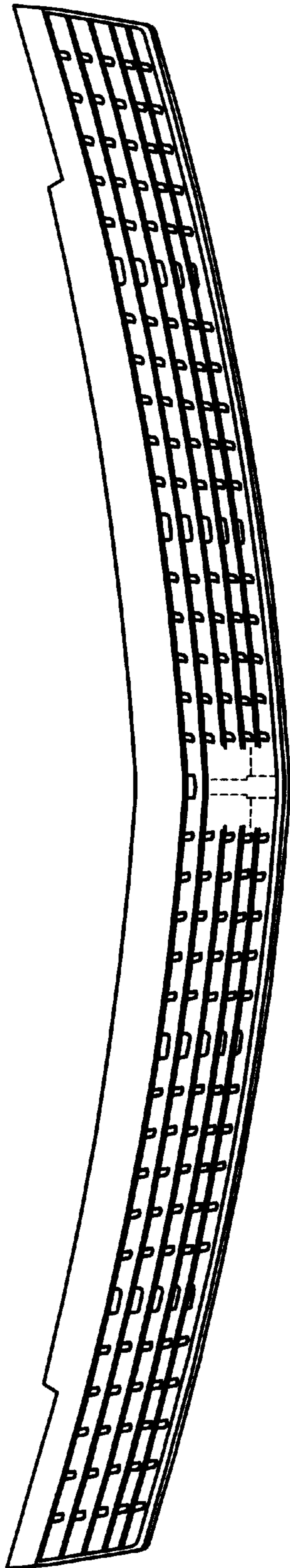

FIG - 4

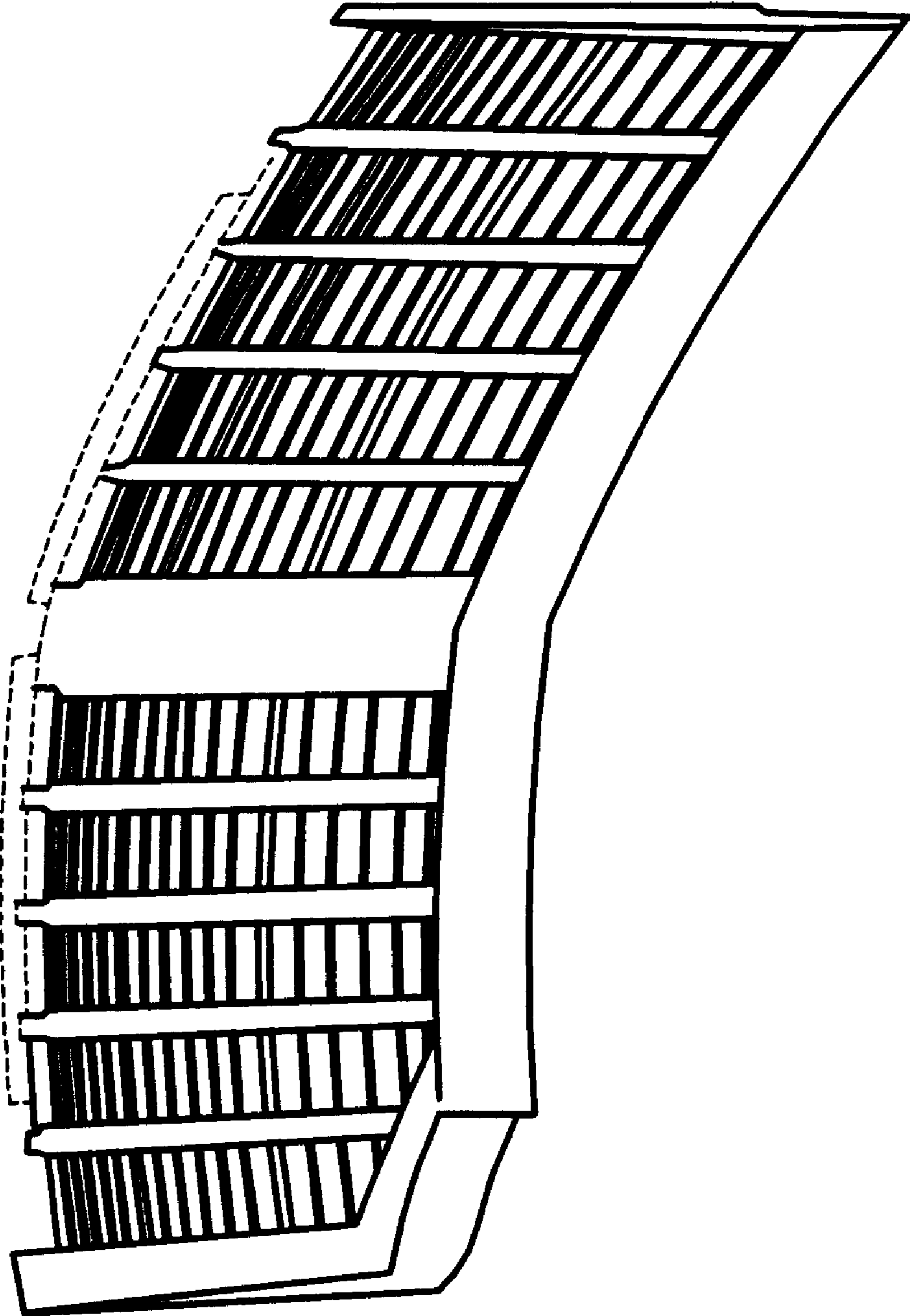

FIG - 5

UNITED STATES PATENT AND TRADEMARK OFFICE
CERTIFICATE OF CORRECTION

PATENT NO. : Des. 541,711 S
APPLICATION NO. : 29/241396
DATED : May 1, 2007
INVENTOR(S) : Edward Golden et al.

Page 1 of 1

It is certified that error appears in the above-identified patent and that said Letters Patent is hereby corrected as shown below:

Front Page

Item (54) delete "AUTOMOBILE LOWER BUMPER"
and insert -- AUTOMOBILE GRILLE --

Item (57) delete "The ornamental design for an automobile lower bumper, as shown and described in FIGS. 1-5"
and insert -- The ornamental design for an automobile grille, as shown and described in FIGS. 1-5. --

Under DESCRIPTION delete "FIG. 1 is a front perspective view of an automobile lower bumper attached to a vehicle, no part of the vehicle is claimed:"
and insert -- FIG. 1 is a front perspective view of an automobile grille attached to a vehicle, no part of the vehicle is claimed: --

Signed and Sealed this

Seventeenth Day of March, 2009



JOHN DOLL
Acting Director of the United States Patent and Trademark Office