



US00D541708S

(12) **United States Design Patent**
Lau et al.

(10) **Patent No.:** **US D541,708 S**
(45) **Date of Patent:** **** May 1, 2007**

(54) **VEHICLE BUMPER**

(75) Inventors: **Chelsia Lau**, Ann Arbor, MI (US);
Patrick Schiavone, Birmingham, MI
(US); **Jeffrey Nowak**, Huntington
Woods, MI (US); **Mark McChesney**,
Saline, MI (US)

(73) Assignee: **Ford Global Technologies, LLC**,
Dearborn, MI (US)

(**) Term: **14 Years**

(21) Appl. No.: **29/237,809**

(22) Filed: **Sep. 7, 2005**

(51) **LOC (8) Cl.** **12-16**

(52) **U.S. Cl.** **D12/169**

(58) **Field of Classification Search** D12/90-92,
D12/86, 169, 196; 296/180.1, 180.2; 293/102,
293/113, 115, 117, 120

See application file for complete search history.

(56) **References Cited**

U.S. PATENT DOCUMENTS

D516,474 S * 3/2006 Honda et al. D12/169
D521,903 S * 5/2006 Matei et al. D12/91
D525,178 S * 7/2006 Tsubaki et al. D12/169
D525,565 S * 7/2006 Karikomi D12/91

OTHER PUBLICATIONS

1999 North American Auto Show (Detroit), Explorer Sport
Trac, stock photo, data unknown.

2001 Auto Show (Geneva), Explorer, stock photo, date
unknown.

2002 North American Auto Show (Detroit), Explorer Sport
Trac, stock photo, data unknown.

TheCarConnection.com, *Spy Shots: '06 Ford Explorer*. A
fresh face for a middle-age warrior. [http://www.thecarcon-
nection.com/Enthusiasts/Spy_Shots/Spy_Shots_06_
Ford_Explorer.S178.A7402.html](http://www.thecarcon-
nection.com/Enthusiasts/Spy_Shots/Spy_Shots_06_
Ford_Explorer.S178.A7402.html), Aug. 9, 2004.
Jalopnik, *Auto Week Reader Snaps Photo of '06 Explorer, or
is that the '04?*, v 54, No. 33, p. 4, [http://www.jalopnik.com/
cars/spy-photos/autoweek-reader-snaps-photo-of-06-
explorer-or-is-that-the-04-019721.php](http://www.jalopnik.com/
cars/spy-photos/autoweek-reader-snaps-photo-of-06-
explorer-or-is-that-the-04-019721.php), Aug. 16, 2004.

(Continued)

Primary Examiner—Melody N. Brown

(74) *Attorney, Agent, or Firm*—Damian Porcari

(57) **CLAIM**

The ornamental design for a vehicle bumper, as shown and
described.

DESCRIPTION

FIG. 1 is a front perspective view of a vehicle bumper
attached to a vehicle, no part of the vehicle is claimed;
FIG. 2 is a front view of the vehicle bumper;
FIG. 3 is a left perspective view of the vehicle bumper;
FIG. 4 is a left side view of the vehicle bumper;
FIG. 5 is a right side view of the vehicle bumper;
FIG. 6 is an enlarged fragmental front view of the area
marked 6 in FIG. 2;
FIG. 7 is a top plan view of the vehicle bumper; and,
FIG. 8 is a right perspective view of the vehicle bumper.
The broken lines are for illustrative purposes only and form
no part of the claimed design.

The stippling indicates the curvature of the front fascia. The
front fascia has an in-board upper curved portion descending
below the generally upper line of the front fascia receiving
a portion of a headlight.

1 Claim, 7 Drawing Sheets

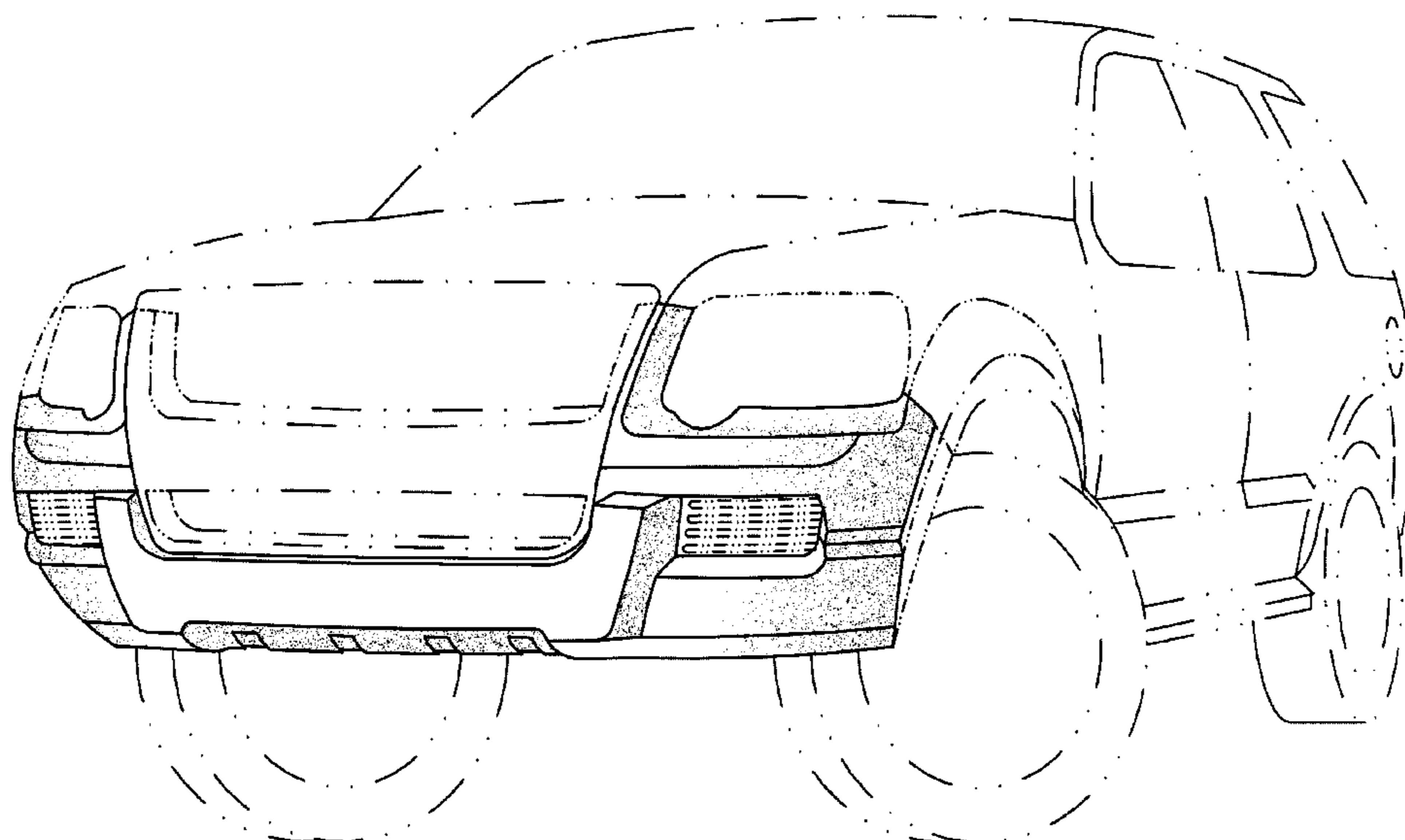

OTHER PUBLICATIONS

Auto Week, *AW Spies*, v 54, No. 33, p. 4, Aug. 16, 2004.

Popular Mechanics, *Detroit Spy Report*, p. 40, Nov. 2004.

Popular Mechanics, *Detroit Spy*, http://www.popularmechanics.com/automotive/spy_reports/1318501.html, Jan. 3, 2005.

Auto Week, *Topic: 2006 Sport Trac photos*, <http://forums.autoweek.com/thread.jspa?forumID=31&threadID=11652&start=60&start=0>, Jan. 13, 2005.

Jalopnik, *Spy Photos: 2007 Ford Sport Trac*, <http://www.jalopnik.com/cars/spy-photos/spy-photos-2007-ford-sport-trac-030973.php>, Jan. 24, 2005.

The Car Connection, *Spy Shots: '07 Explorer Sport Trac*, From concept to reality—really, really quickly. http://www.thecarconnection.com/Enthusiasts/Spy_Shots/Spy_Shots_07_Explorer_Sport_Trac.S178.A8021.html, Jan. 24, 2005.

The Detroit News, *Autos Insider: Ford Sport Trac a preview of the new Explorer*, <http://info.detnews.com/autosinsider/sneakpeek/index.cfm?id=18254>, Feb. 2, 2005.

Automotive News, *Web watchers offer early read on autos*, v 79, No. 6140, p. 8, Mar. 28, 2005.

The Car Lounge, *2006 Ford Explorer*, <http://forums.thecar-lounge.net/zerthread?id=1910776>, Mar. 30, 2005.

TheCarConnection.com, *Spy Shots: '06 Ford Explorer*, A sharper image of the perennial best-selling SUV. http://www.thecarconnection.com/Enthusiasts/Spy_Shots/Spy_Shots_06_Ford_Explorer.S178.A847.html, May 2, 2005.

Automotive News, *Exploring a new look*, p. 1, May 2, 2005.

Auto Week, *Exploring its Options: 2006 Ford Explorer gets new face and an optional Mustang V8*, <http://www.autoweek.com/article.cms?articleId=102311>, May 9, 2005.

TheCarConnection.com, *Future Cars: Ford/PAG/Mazda*, http://www.thecarconnection.com/Enthusiasts/Future_Cars/Ford.S283.A8367.html, May 16, 2005.

Motor Trend's Truck Trend, *News Front: Explorer Sport Trac*, p. 14, May/June 2005.

Motor Trend, *'06 Ford Explorer—Climbing Every Mountain*, p. 30, June 2005.

Popular Mechanics, *Detroit Spy Report*, p. 46, July 2005.

Edmunds.com, *2006 Ford Explorer Midsize SUV*, http://www.edmunds.com/future/2006/ford/explorer/100536557/preview.html?tid=edmunds.f.photos.leftsidenav..0.Ford*, date unknown.

Automobile Magazine Online, *2006 SUV Sneak Preview*, http://www.automobilemag.com/2006_sneak_preview/0503_sp_suv/, date unknown.

* cited by examiner

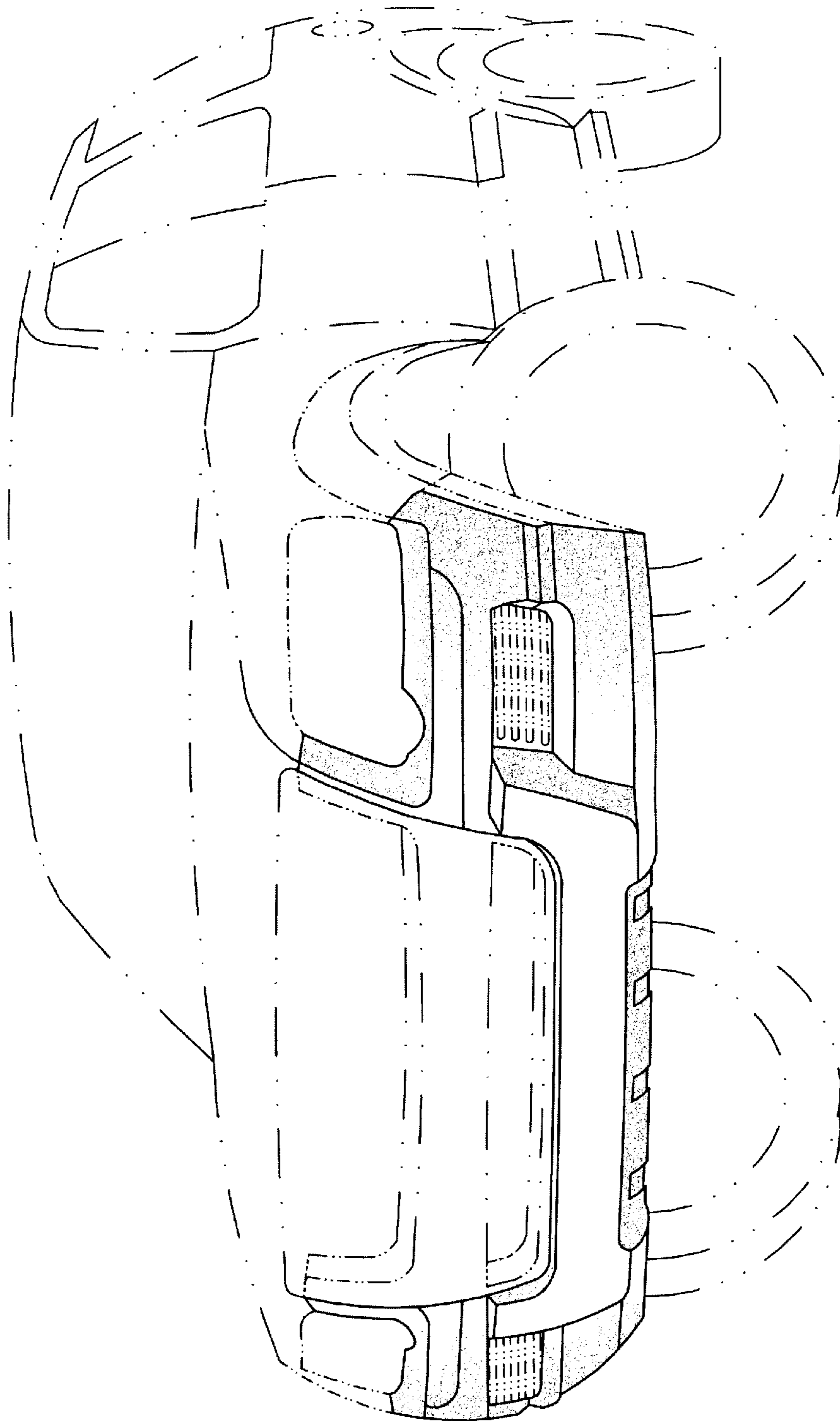

Figure 1

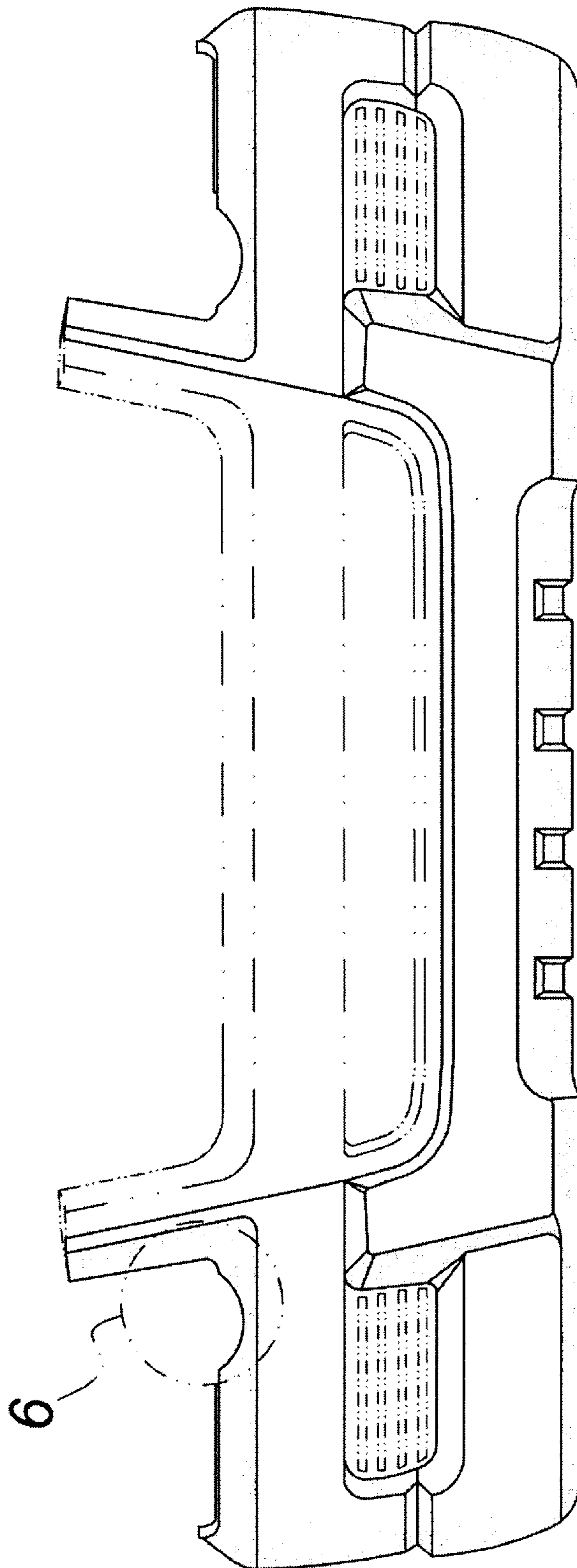

Figure 2

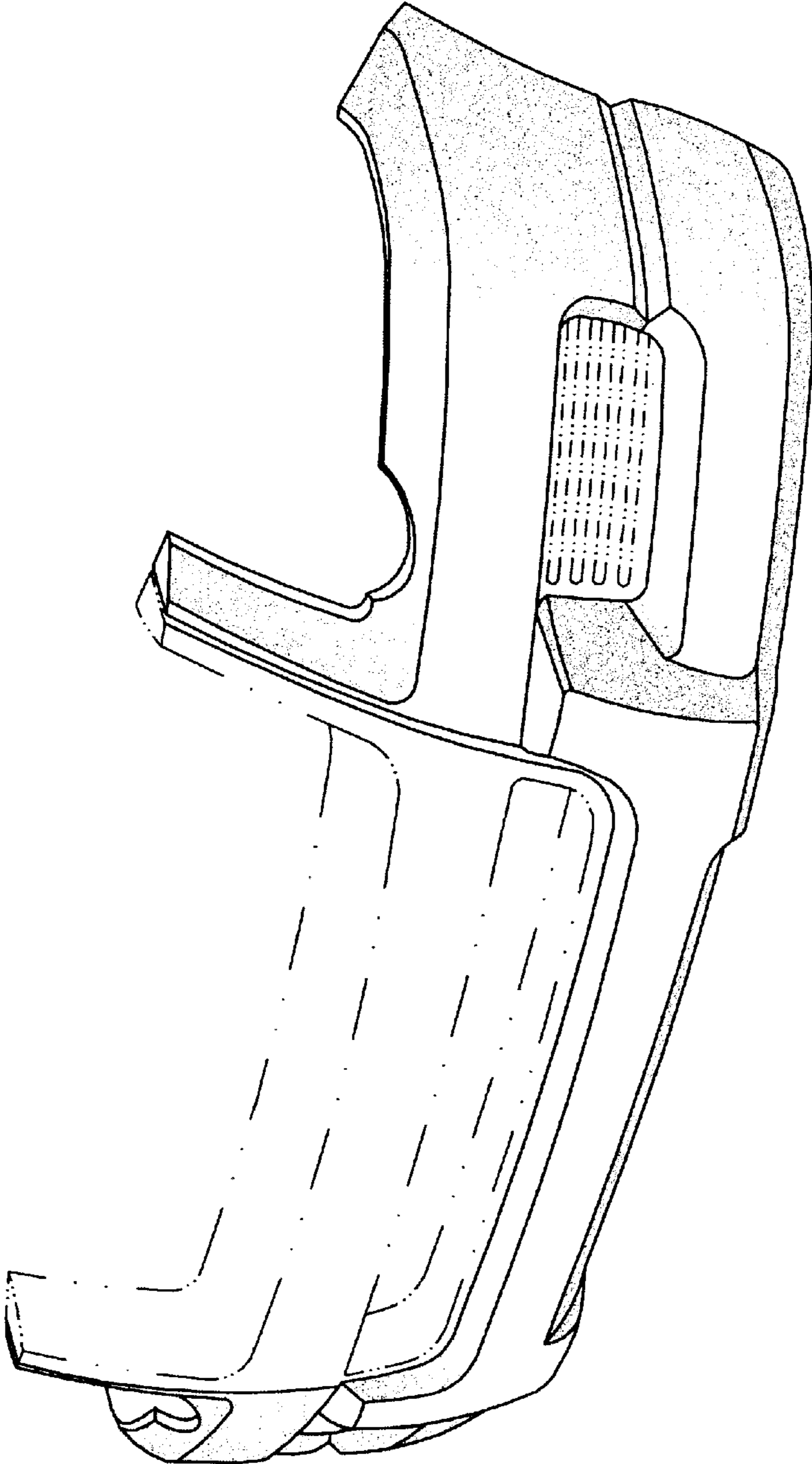

Figure 3

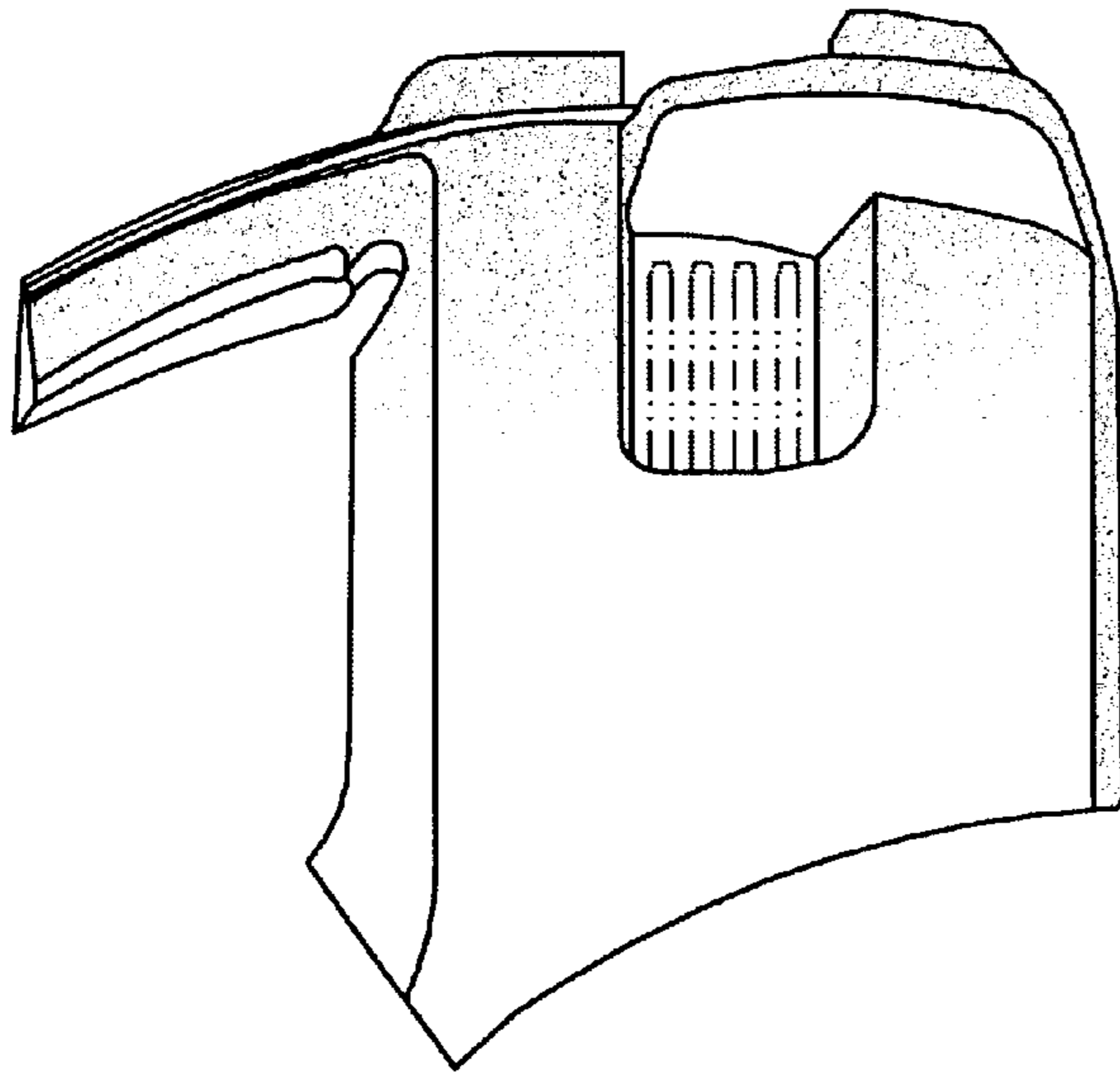

Figure 5

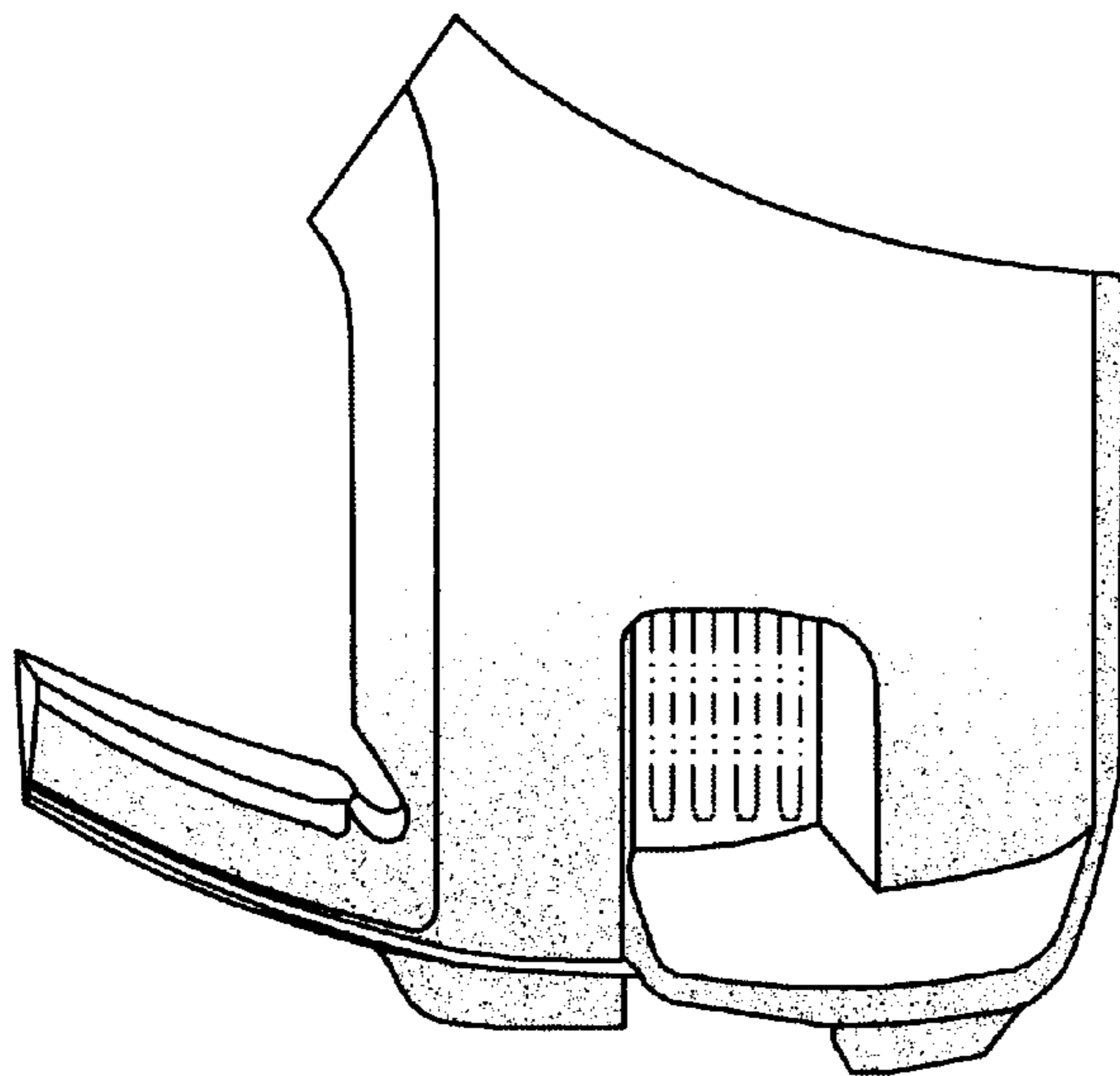

Figure 4

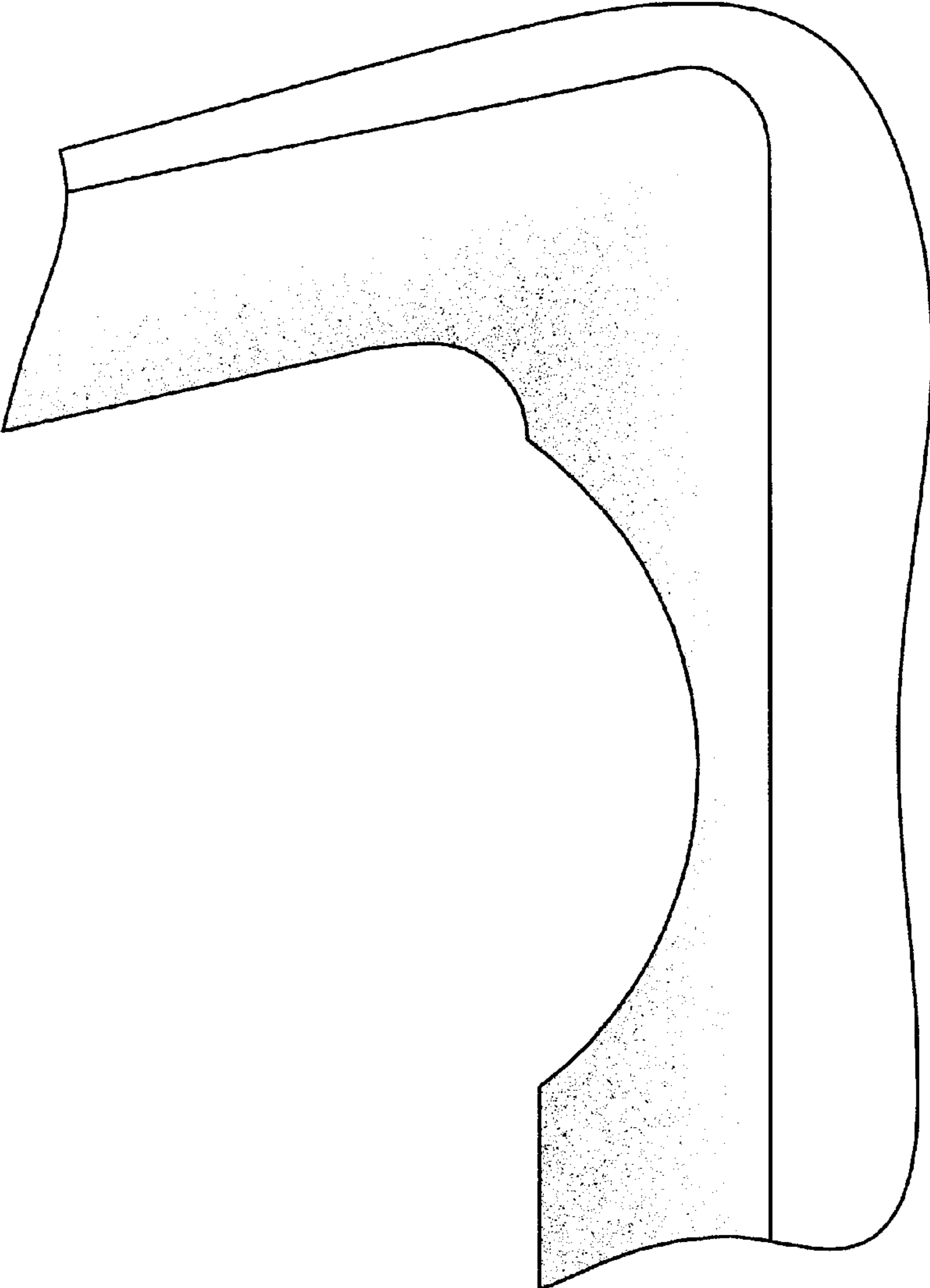

Figure 6

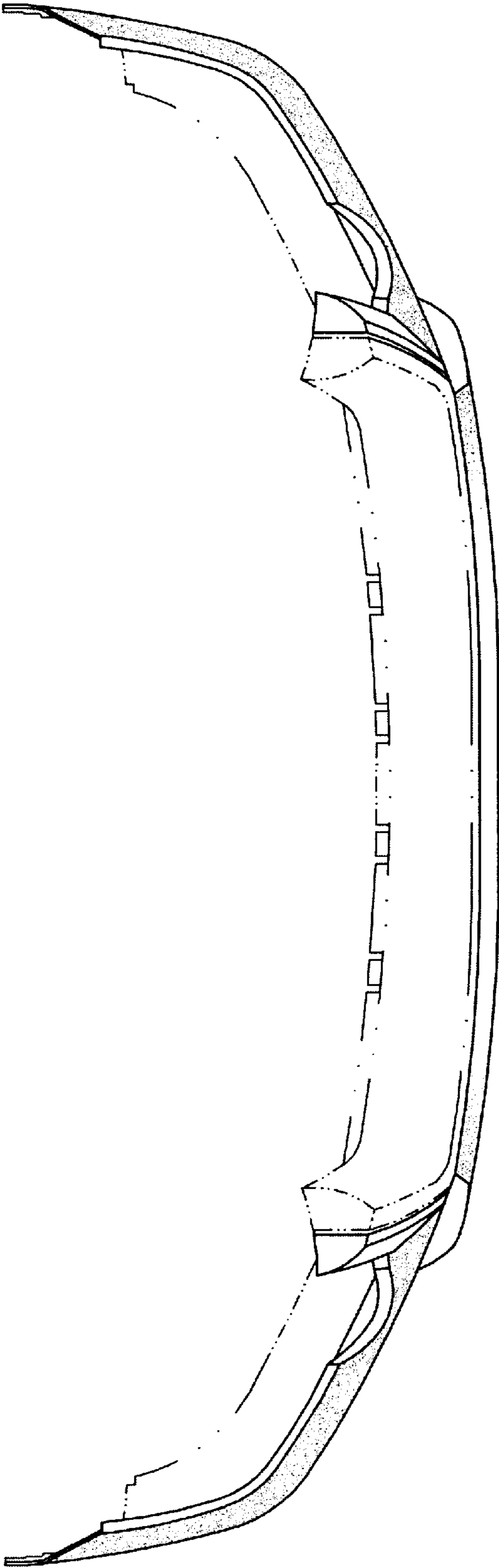

Figure 7

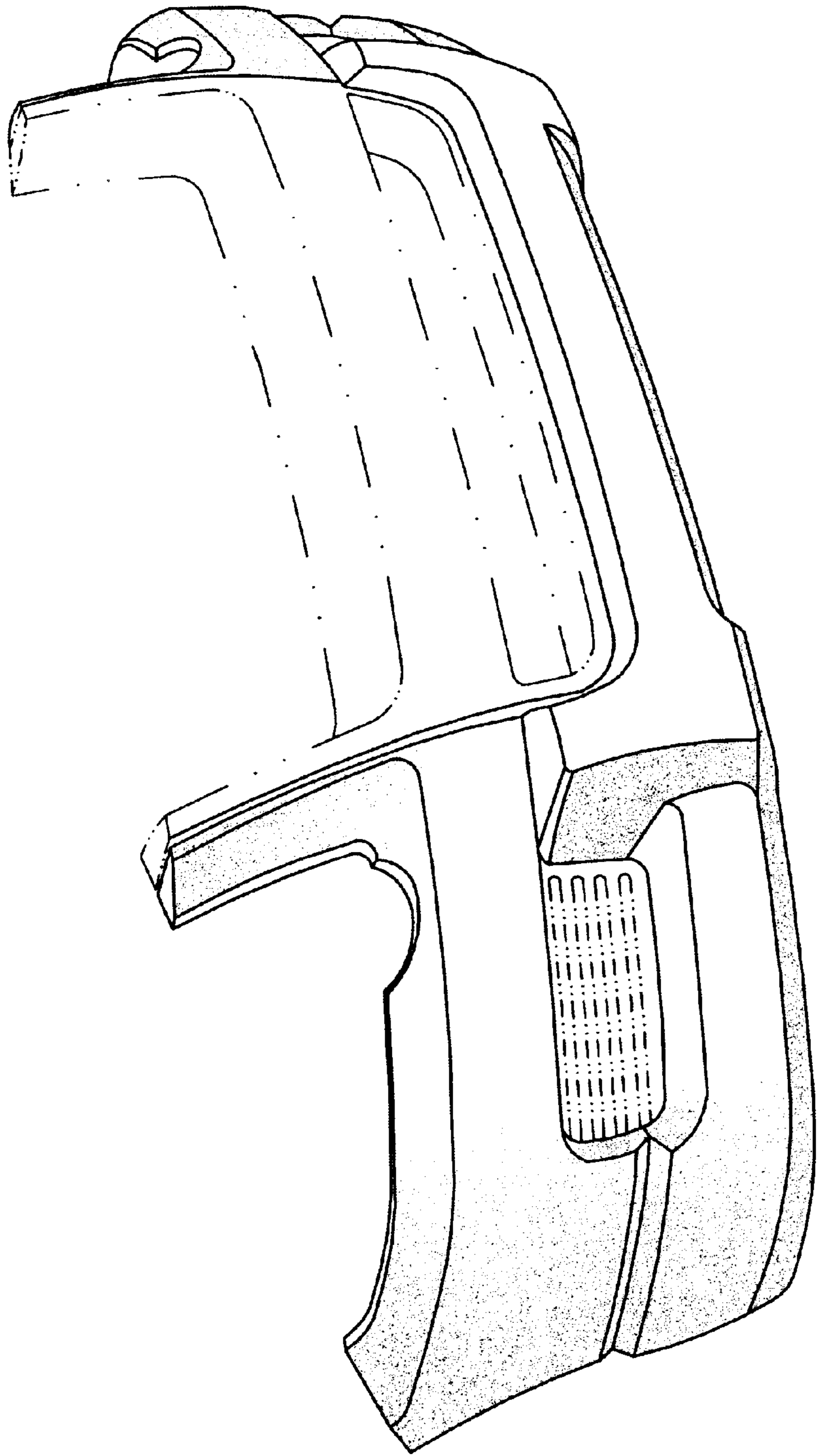

Figure 8