



US00D541704S

(12) **United States Design Patent**  
**Tanaka et al.**

(10) **Patent No.:** **US D541,704 S**

(45) **Date of Patent:** **\*\* May 1, 2007**

(54) **ALL TERRAIN VEHICLE**

(75) Inventors: **Shunji Tanaka**, Kobe (JP); **Seiichi Ino**,  
Kakogawa (JP); **Chiho Yaginuma**,  
Kobe (JP)

(73) Assignee: **Kawasaki Jukogyo Kabushiki Kaisha**,  
Kobe (JP)

(\*\*) Term: **14 Years**

(21) Appl. No.: **29/258,888**

(22) Filed: **Apr. 28, 2006**

(51) **LOC (8) Cl.** ..... **12-11**

(52) **U.S. Cl.** ..... **D12/107**

(58) **Field of Classification Search** ..... D12/3,  
D12/86, 87, 107, 110; 180/225, 229, 233,  
180/311, 312

See application file for complete search history.

D446,475 S	8/2001	Luh
D448,325 S	9/2001	Fujieda
D452,835 S	1/2002	Aoki et al.
D458,562 S	6/2002	Kalhok et al.
D485,212 S	1/2004	Wu
D485,213 S	1/2004	Wu
D491,108 S	6/2004	Tamura
D491,491 S	6/2004	Luh
D511,123 S	11/2005	Lin
D513,208 S	12/2005	Lin
D513,396 S	1/2006	Lin
D515,976 S	2/2006	Lin

*Primary Examiner*—Alan P. Douglas

*Assistant Examiner*—Linda Brooks

(74) *Attorney, Agent, or Firm*—Alleman Hall McCoy  
Russell & Tuttle LLP

(57) **CLAIM**

The ornamental design for an all terrain vehicle, as shown  
and described.

**DESCRIPTION**

FIG. 1 is a front view of an all terrain vehicle according to  
the present invention.

FIG. 2 is a rear view of the all terrain vehicle of FIG. 1.

FIG. 3 is a left side view of the all terrain vehicle of FIG. 1.

FIG. 4 is a right side view of the all terrain vehicle of FIG.  
1.

FIG. 5 is a top view of the all terrain vehicle of FIG. 1.

FIG. 6 is a bottom view of the all terrain vehicle of FIG. 1.

FIG. 7 is perspective view of the front of the all terrain  
vehicle of FIG. 1; and,

FIG. 8 is perspective view of the rear of the all terrain  
vehicle of FIG. 1.

The broken lines show environment, and form no part of the  
claimed design.

(56) **References Cited**

U.S. PATENT DOCUMENTS

D285,058 S	8/1986	Takagaki
D285,424 S	9/1986	Hishinuma
D286,866 S	11/1986	Makita et al.
D295,153 S	4/1988	Ryuzoji et al.
D295,273 S	4/1988	Saito et al.
D298,113 S	10/1988	Tamura et al.
D298,744 S	11/1988	Saito et al.
D298,745 S	11/1988	Takagaki
D298,812 S	12/1988	Miyata
D299,707 S	2/1989	Makita et al.
D327,457 S	6/1992	Saito
D330,694 S	11/1992	Kimura et al.
D349,078 S	7/1994	Kimura et al.
D412,464 S	8/1999	Ichihara et al.
D438,823 S	3/2001	Luh
D445,363 S	7/2001	Luh

**1 Claim, 8 Drawing Sheets**

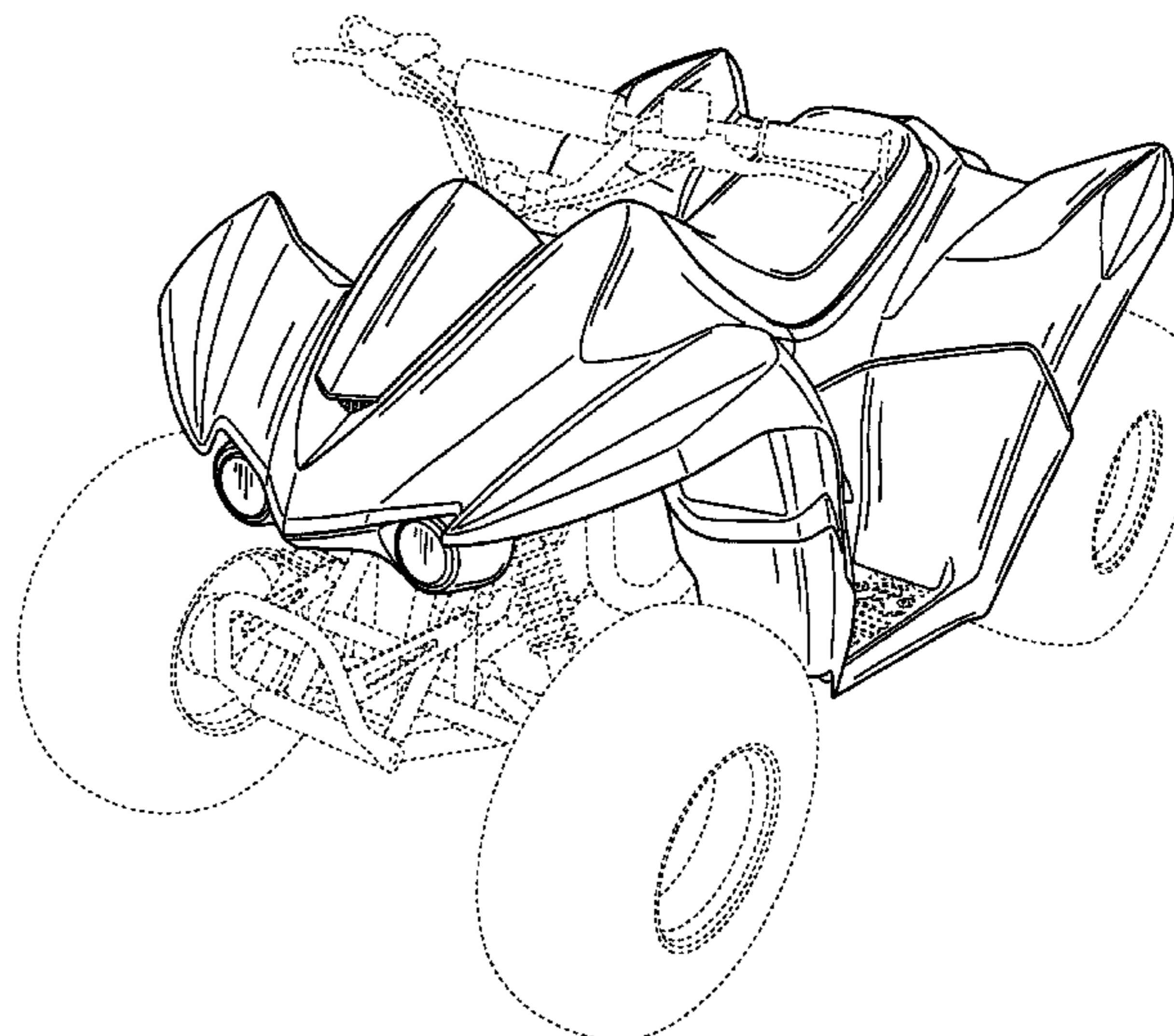
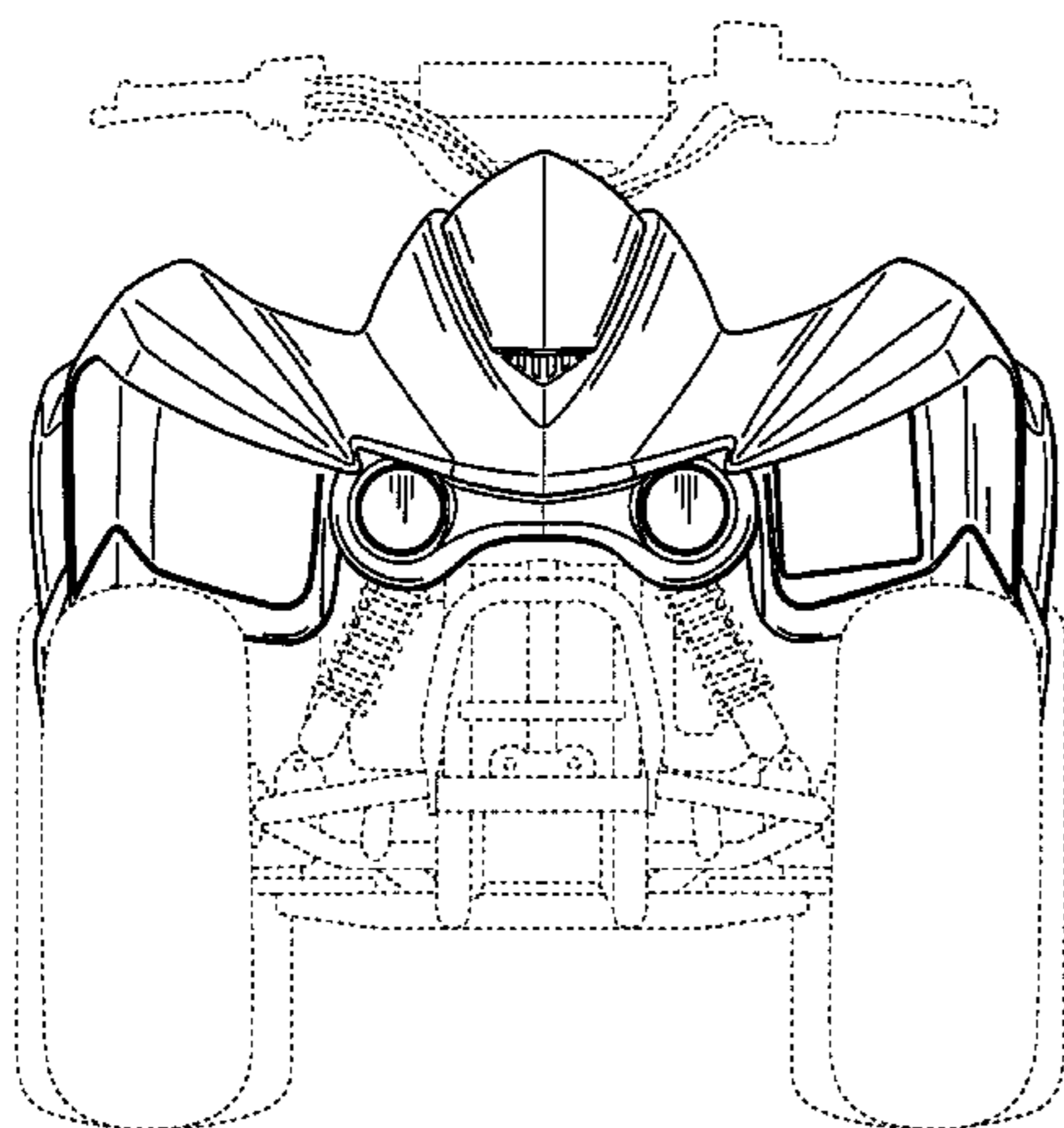

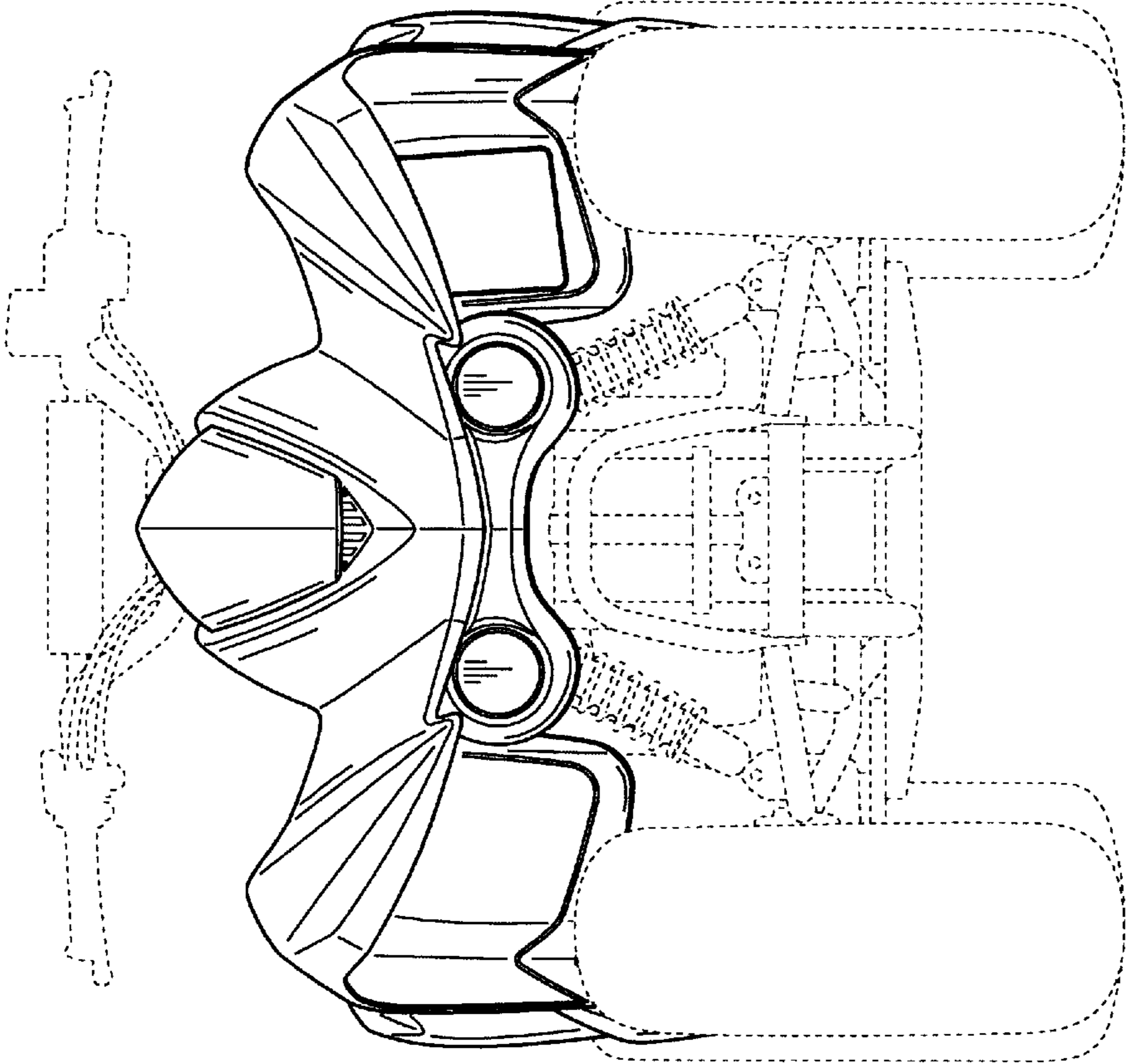

FIG.1

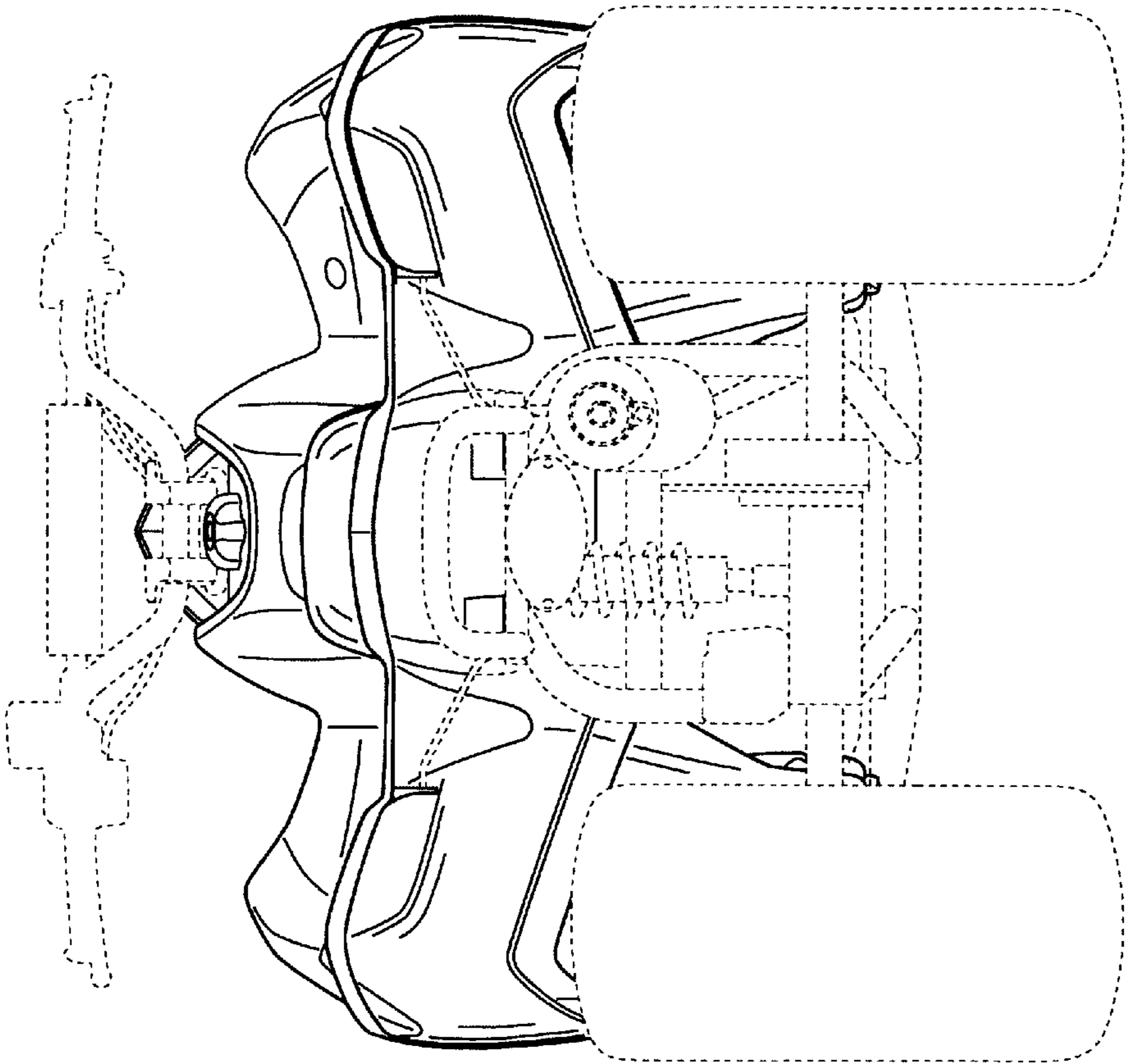

FIG.2

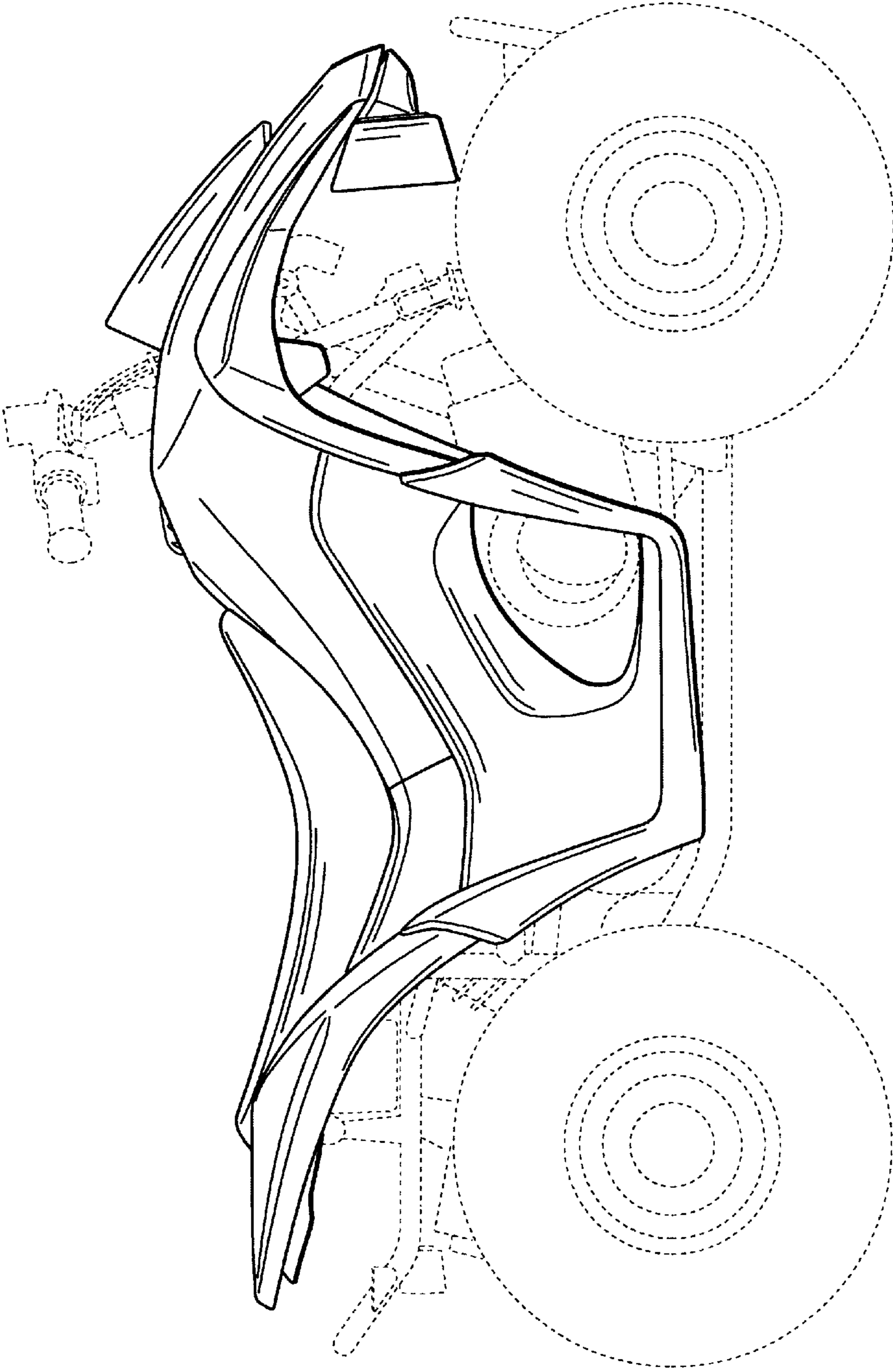

FIG.3

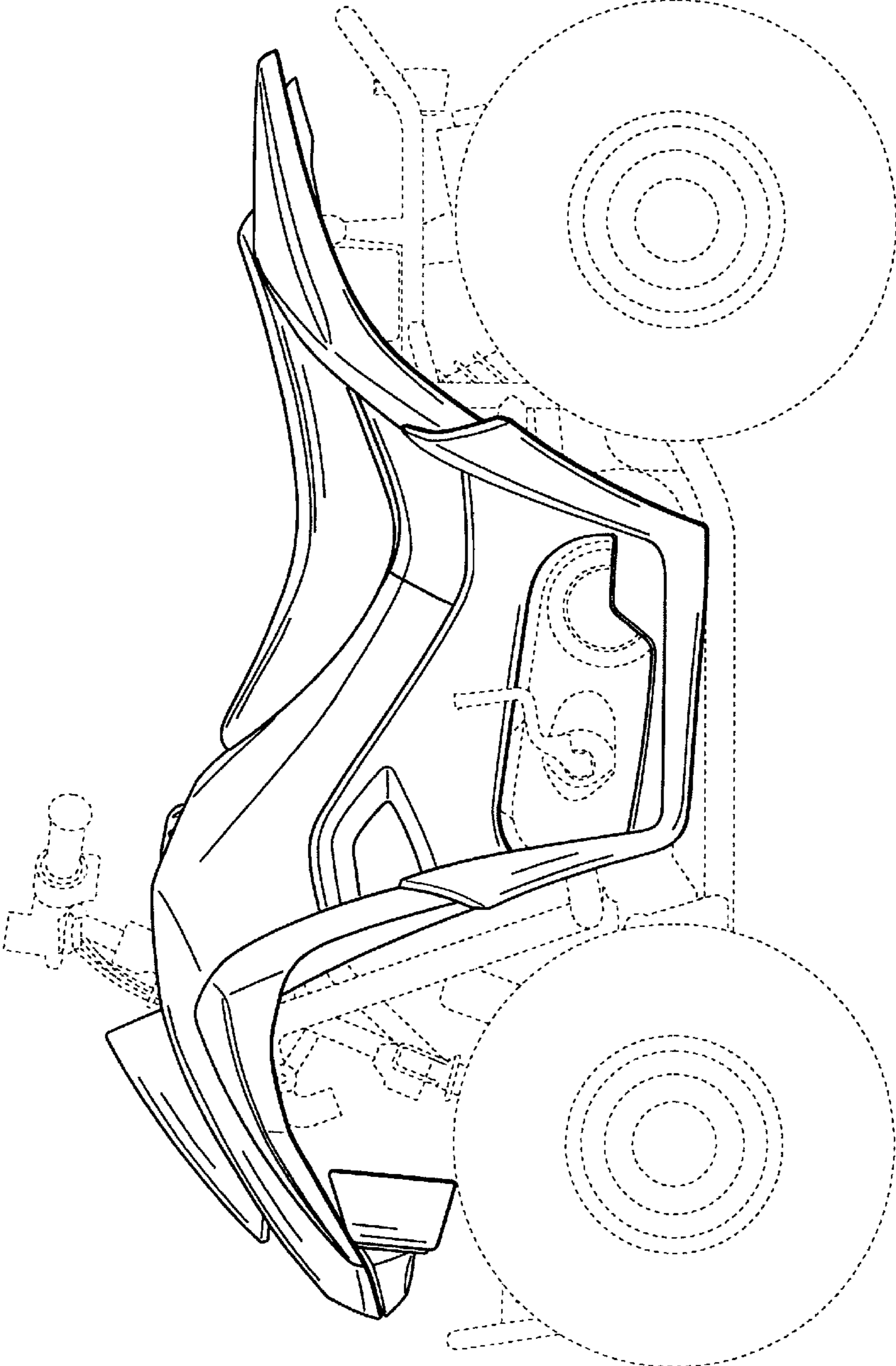

FIG.4

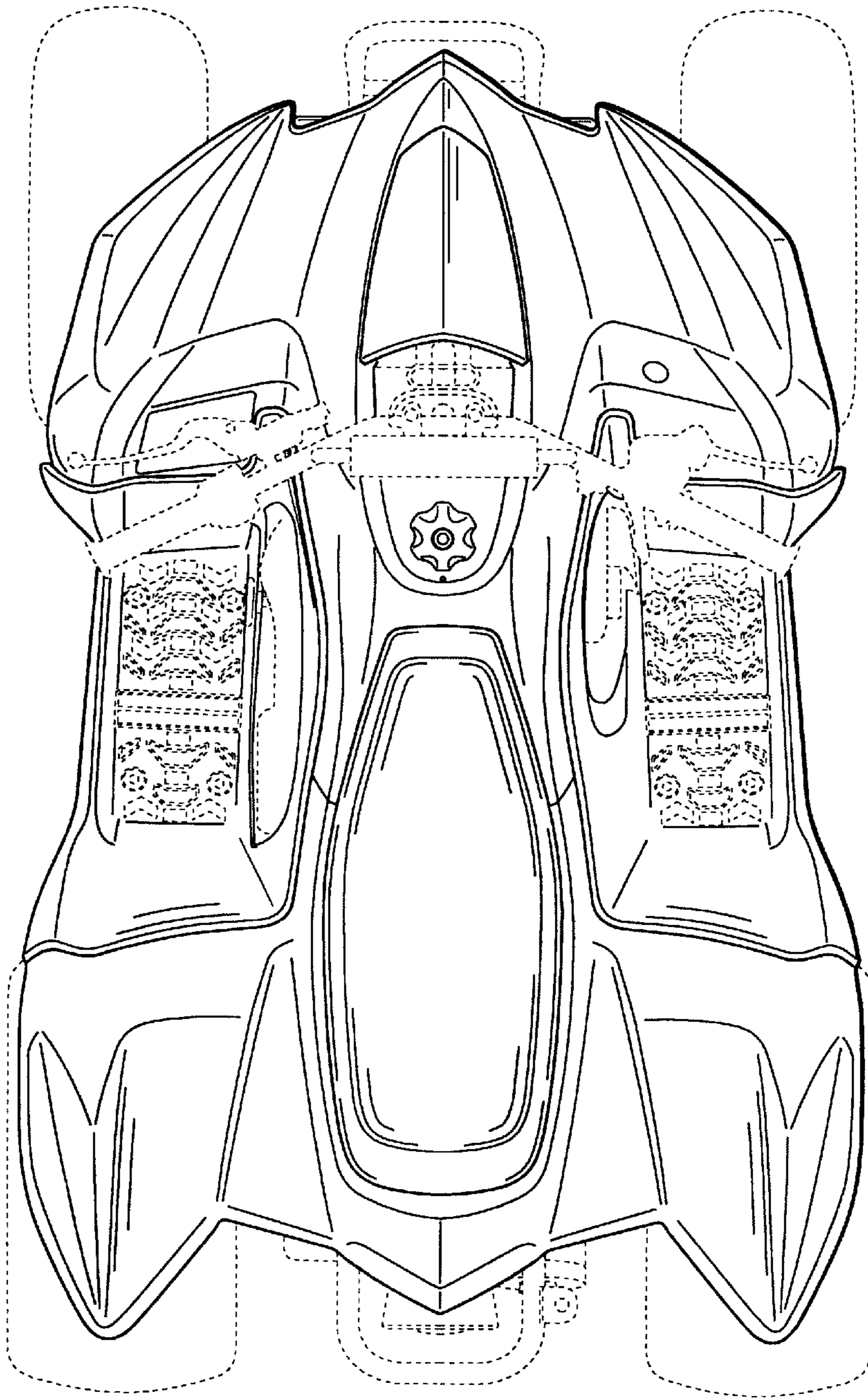

FIG. 5

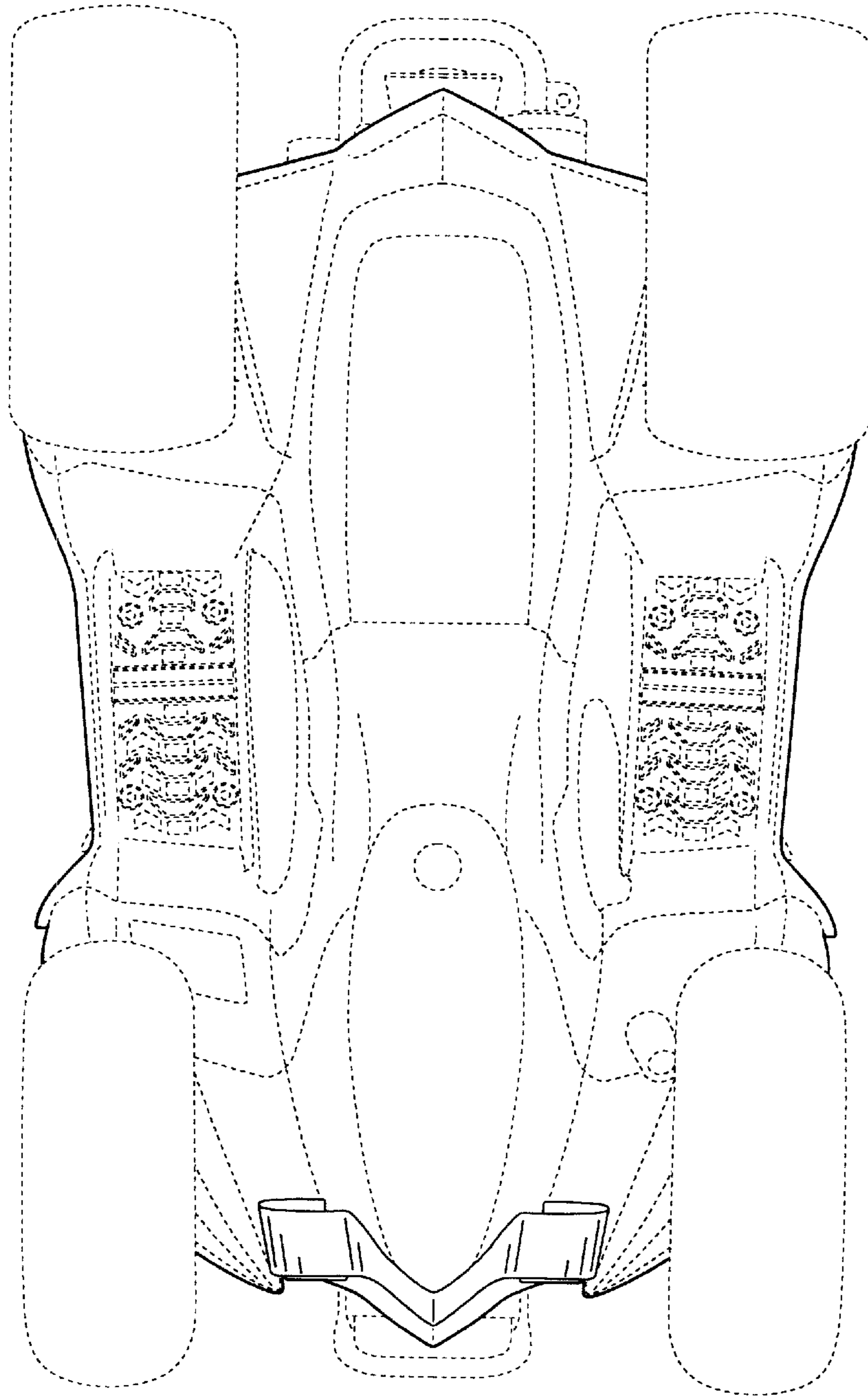

FIG.6

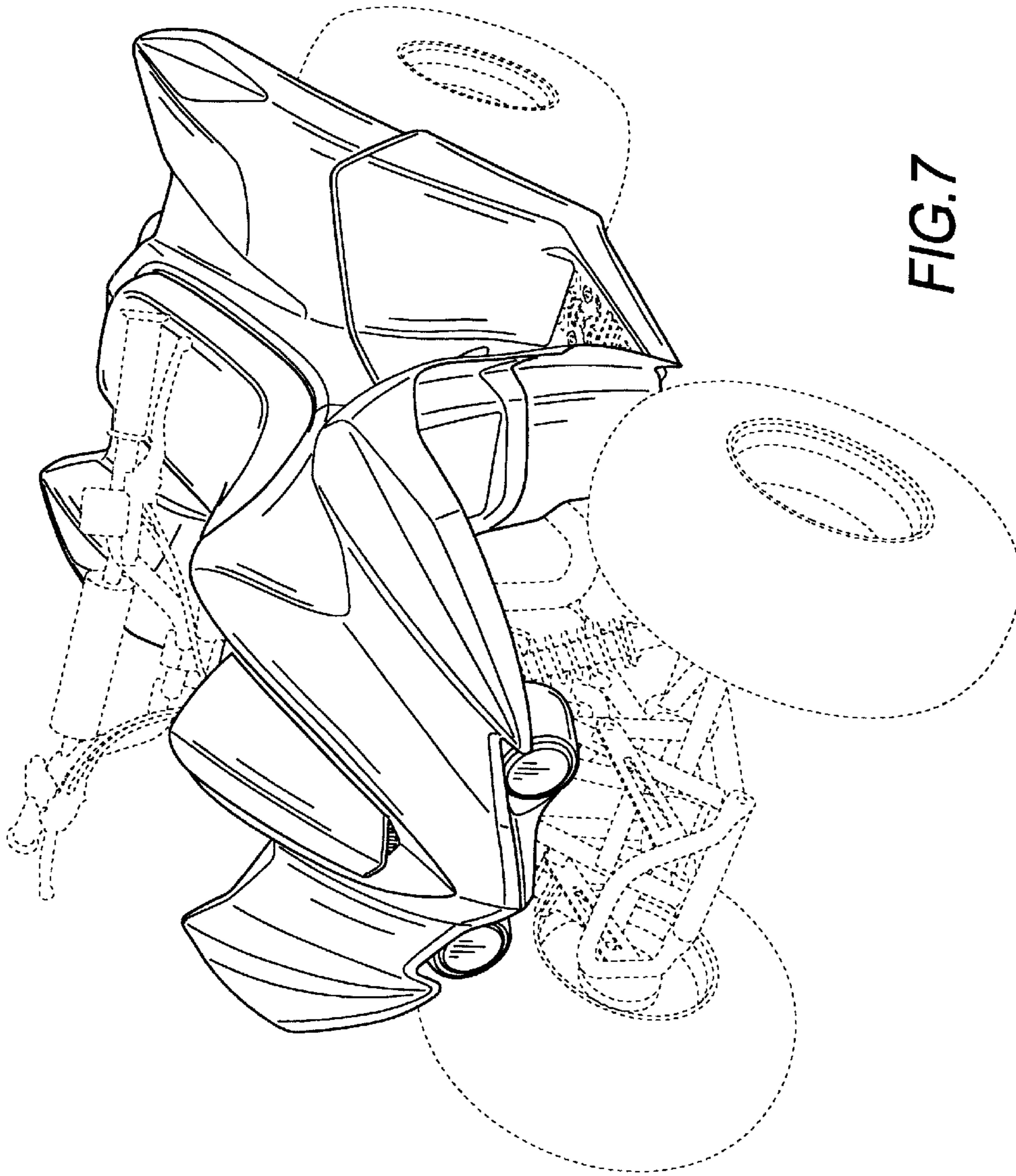

FIG. 7



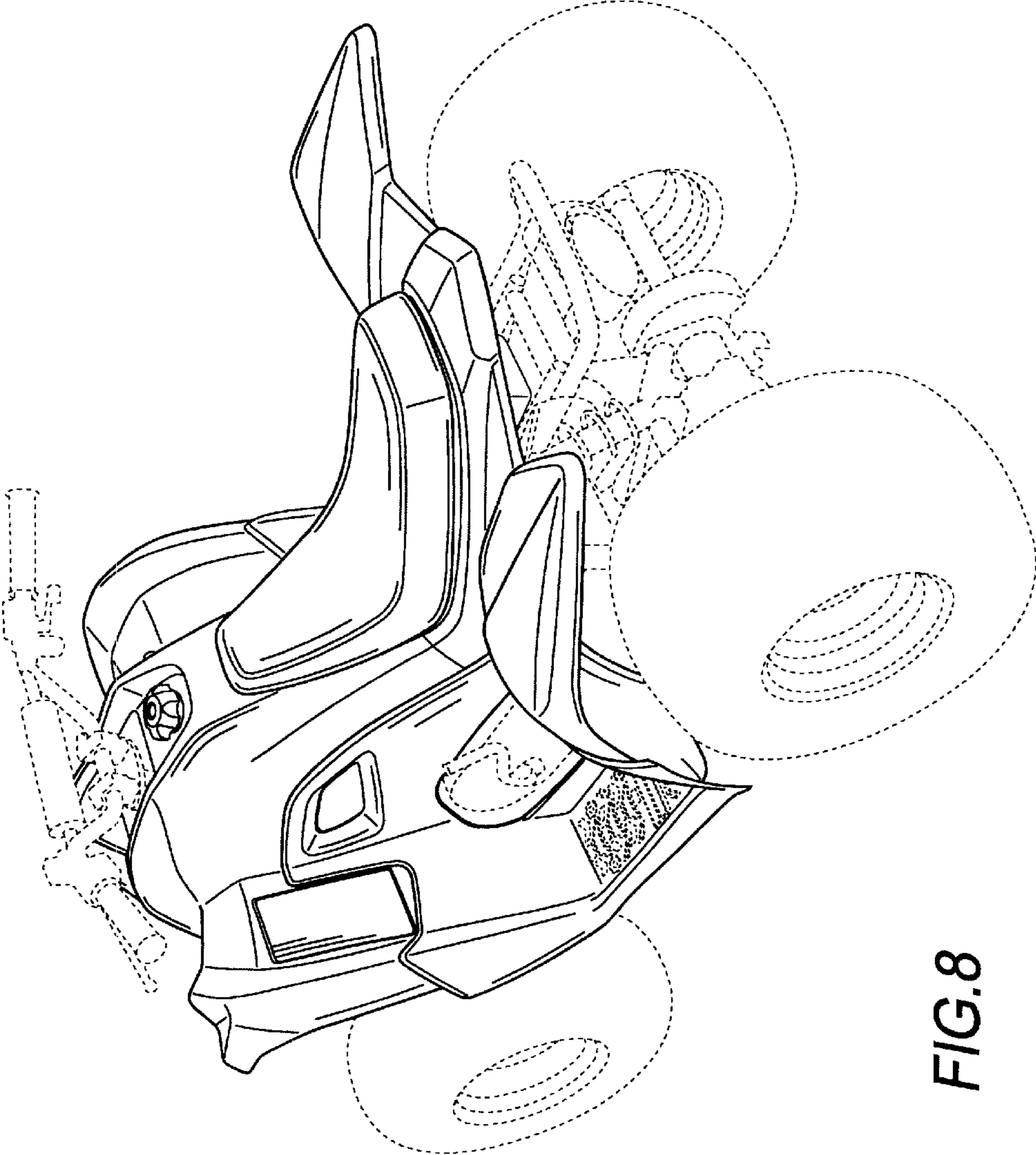

FIG.8