



US00D541492S

(12) **United States Design Patent**
Nam

(10) **Patent No.:** **US D541,492 S**

(45) **Date of Patent:** **** Apr. 24, 2007**

(54) **WASHING MACHINE**

(75) **Inventor:** **Yeon Young Nam**, Goyang-si (KR)

(73) **Assignee:** **Samsung Electronics Co., Ltd.** (KR)

(**) **Term:** **14 Years**

(21) **Appl. No.:** **29/257,179**

(22) **Filed:** **Mar. 30, 2006**

(30) **Foreign Application Priority Data**

Dec. 20, 2005 (KR) 30-2005-0043024

(51) **LOC (8) Cl.** **15-05**

(52) **U.S. Cl.** **D32/6**

(58) **Field of Classification Search** D32/1,
D32/5-10, 25, 28; 68/3 R, 5 R, 12.01; 34/523-524;
312/31

See application file for complete search history.

(56) **References Cited**

U.S. PATENT DOCUMENTS

2,416,405 A * 2/1947 Purpura 34/134
D465,307 S * 11/2002 Du et al. D32/6
D465,622 S * 11/2002 Wang et al. D32/6
D496,513 S * 9/2004 Tsuda et al. D32/8
D515,256 S * 2/2006 Tsuda et al. D32/5

D517,256 S * 3/2006 Kim D32/6
D520,193 S * 5/2006 Yokoyama D32/5
D524,493 S * 7/2006 Choi et al. D32/6

* cited by examiner

Primary Examiner—Louis S. Zarfaz

Assistant Examiner—Kathleen Sims

(74) *Attorney, Agent, or Firm*—Irving Keschner

(57) **CLAIM**

The ornamental design for washing machine, as shown.

DESCRIPTION

FIG. 1 is a perspective view of the ornamental design of the present invention;

FIG. 2 is a front elevational view of the ornamental design of the present invention;

FIG. 3 is a rear elevational view of the ornamental design of the present invention;

FIG. 4 is a left side elevational view of the ornamental design of the present invention;

FIG. 5 is a right side elevational view of the ornamental design of the present invention;

FIG. 6 is a top plan view of the ornamental design of the present invention; and,

FIG. 7 is a bottom view of the ornamental design of the present invention.

1 Claim, 6 Drawing Sheets

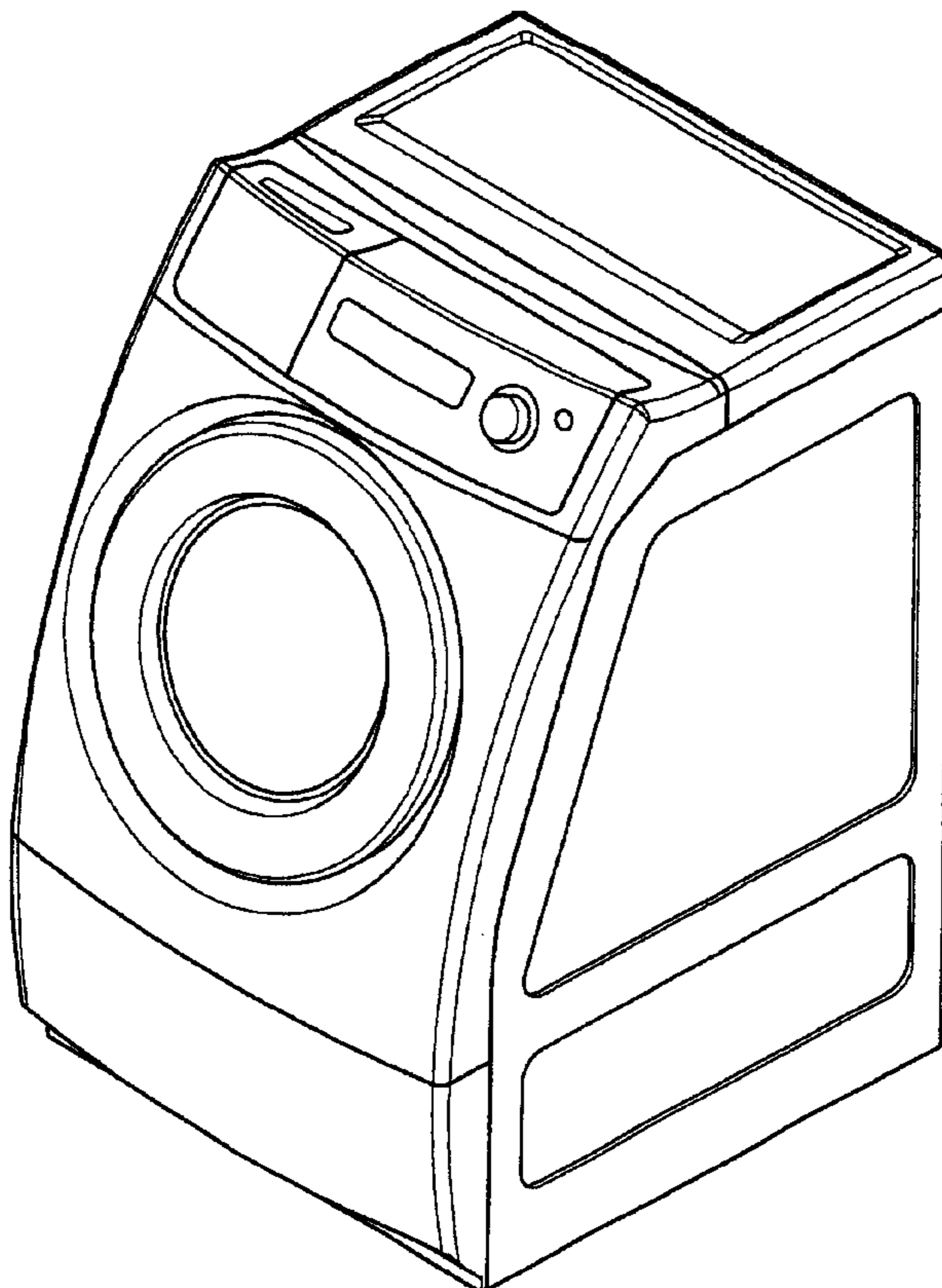
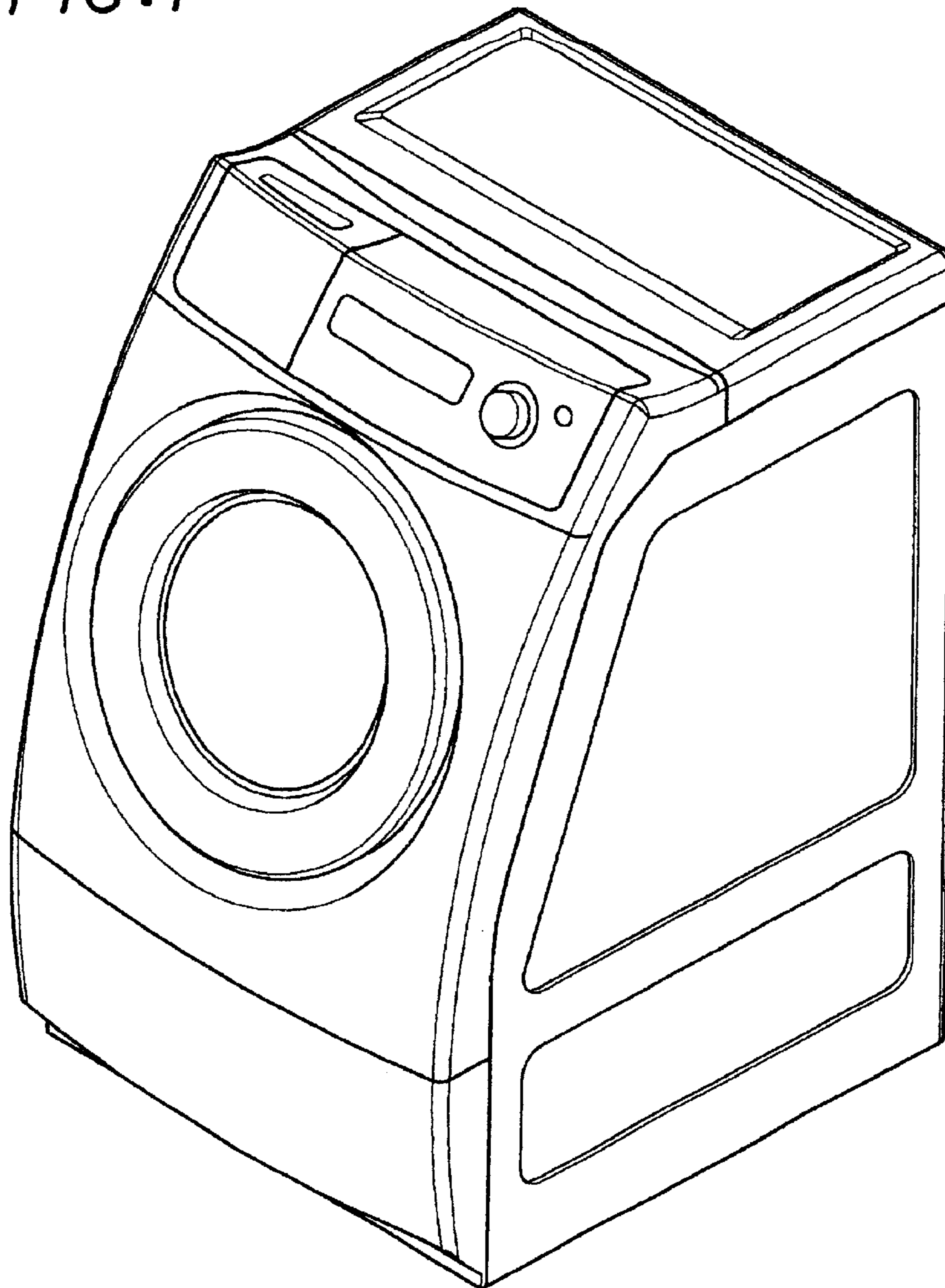

FIG. 1



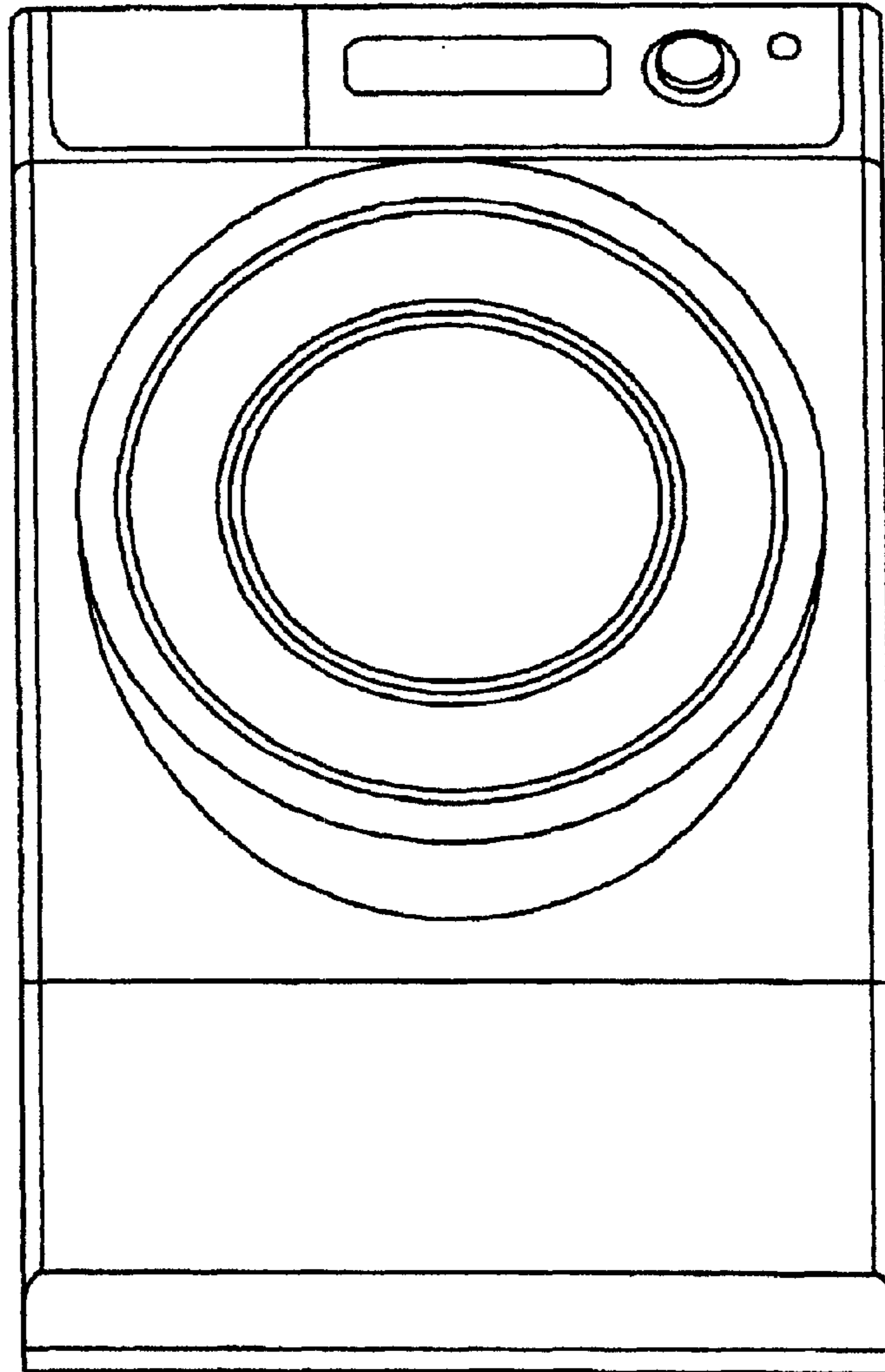

FIG. 2

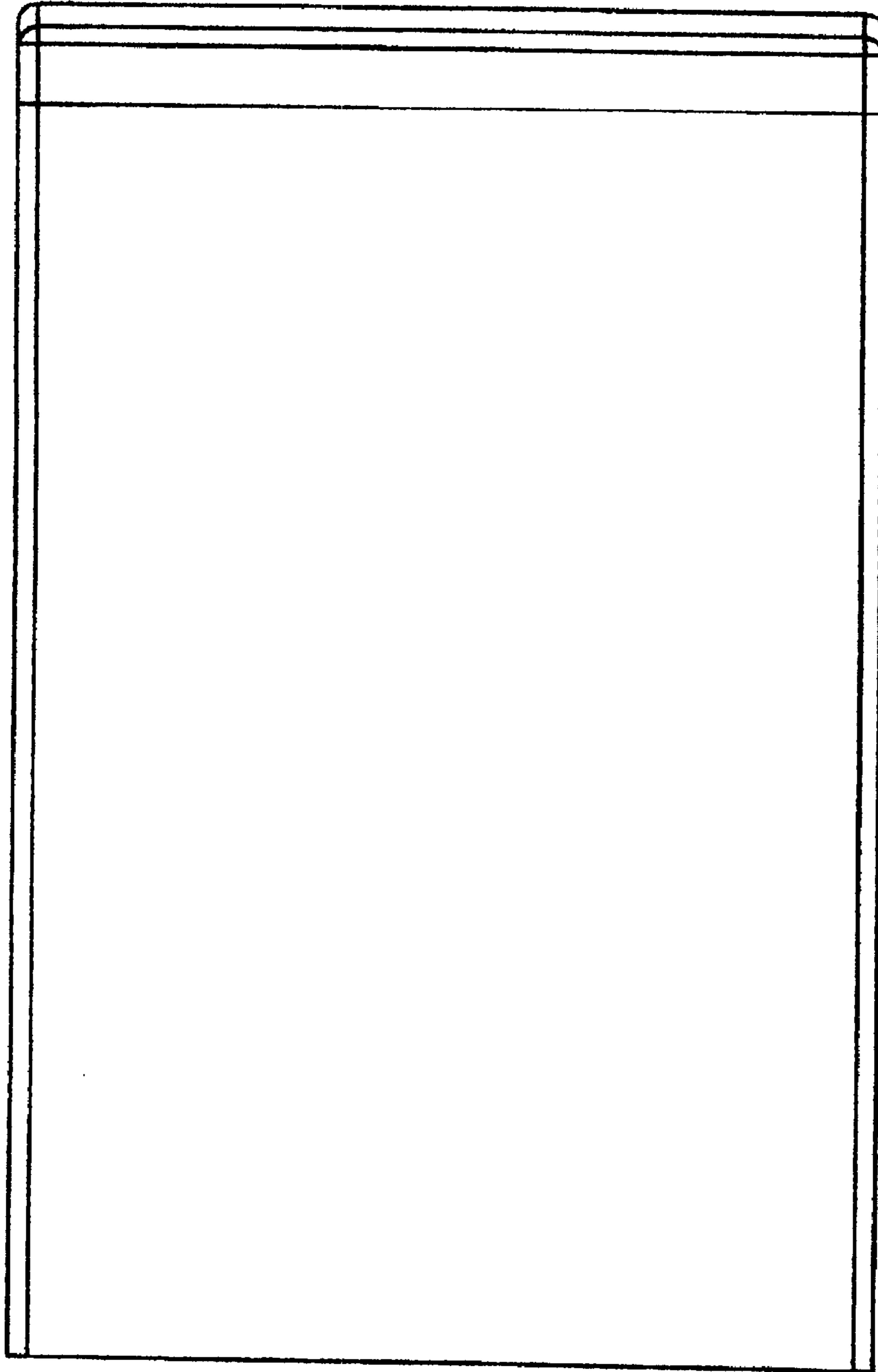

FIG. 3

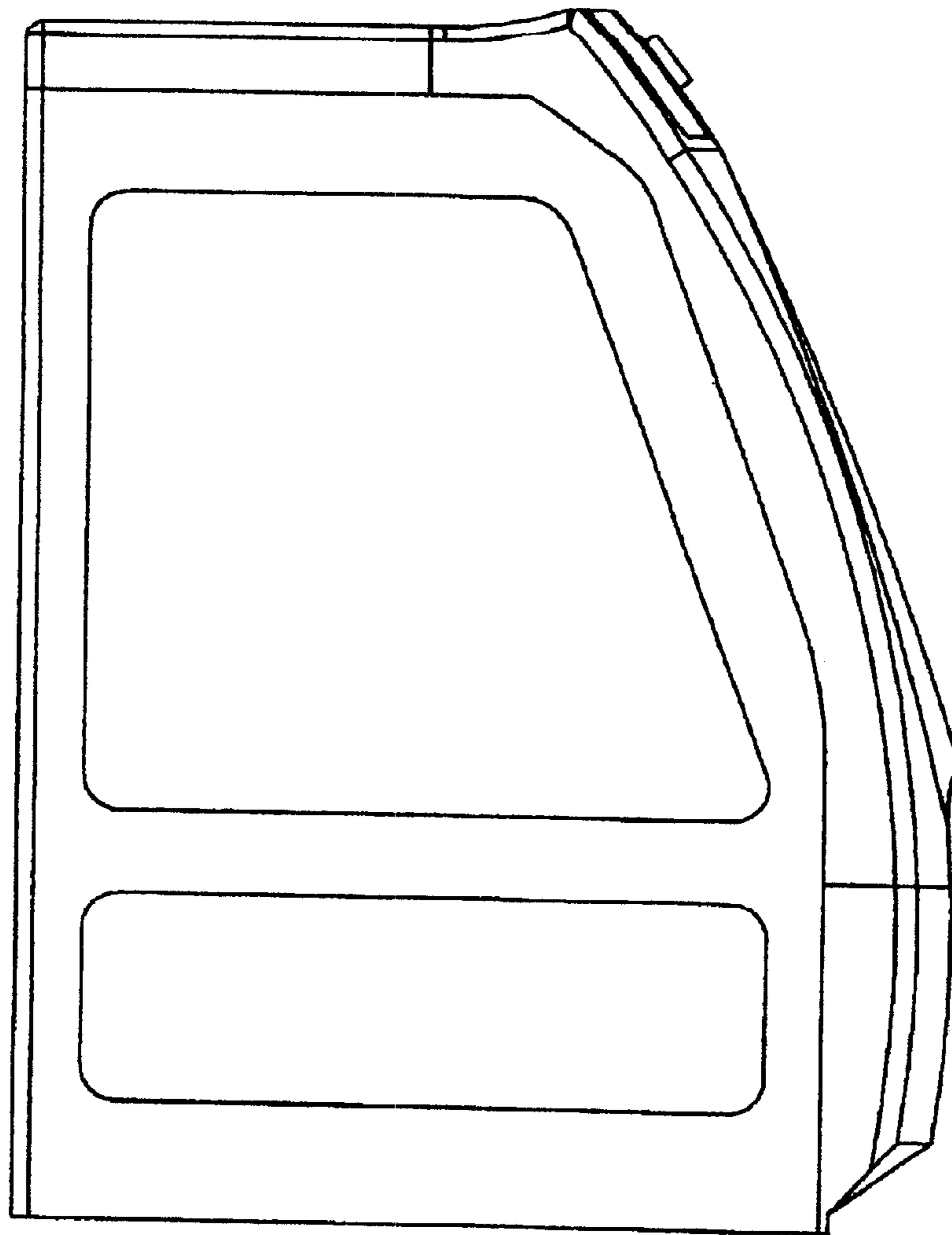

FIG. 4

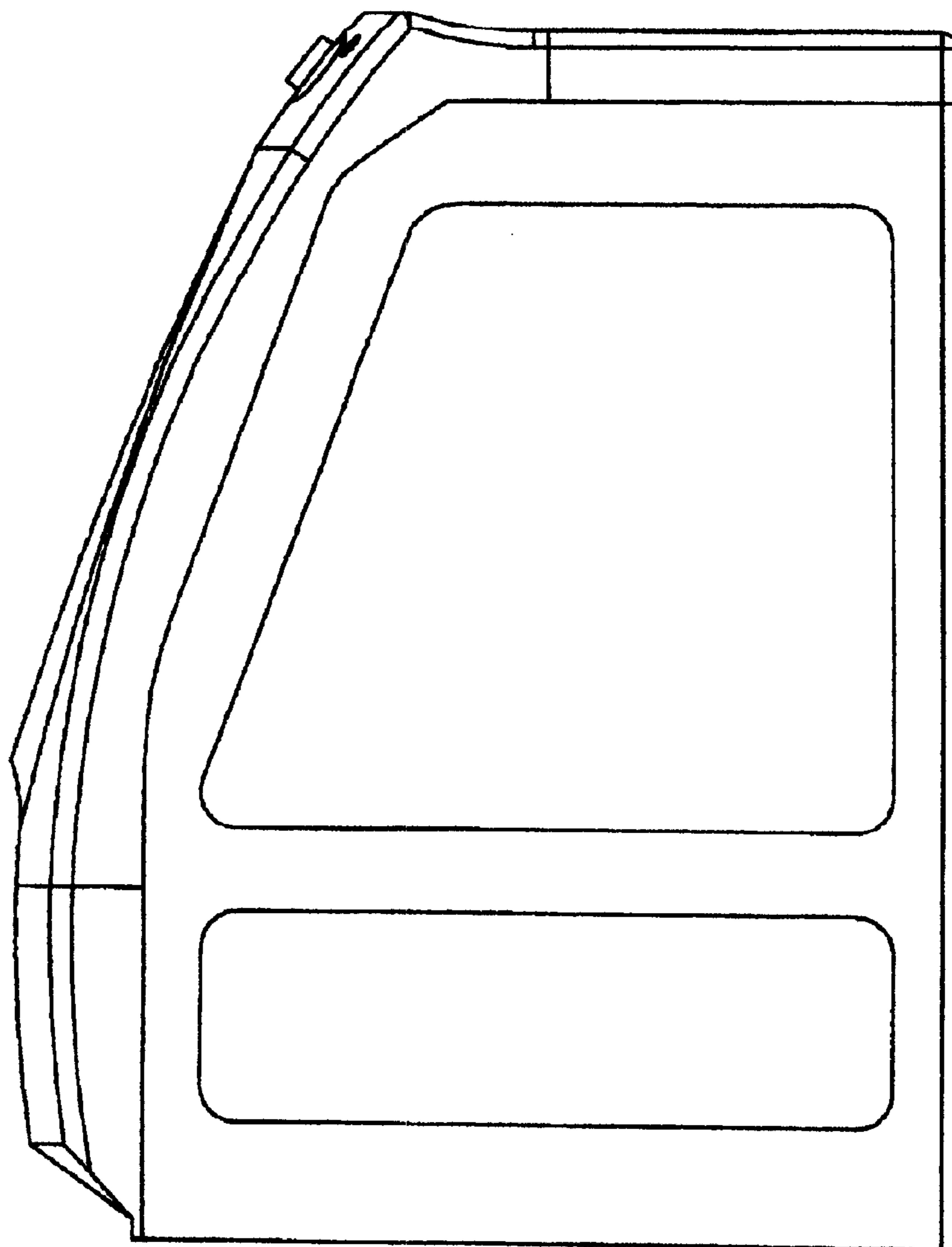

FIG. 5

FIG. 6

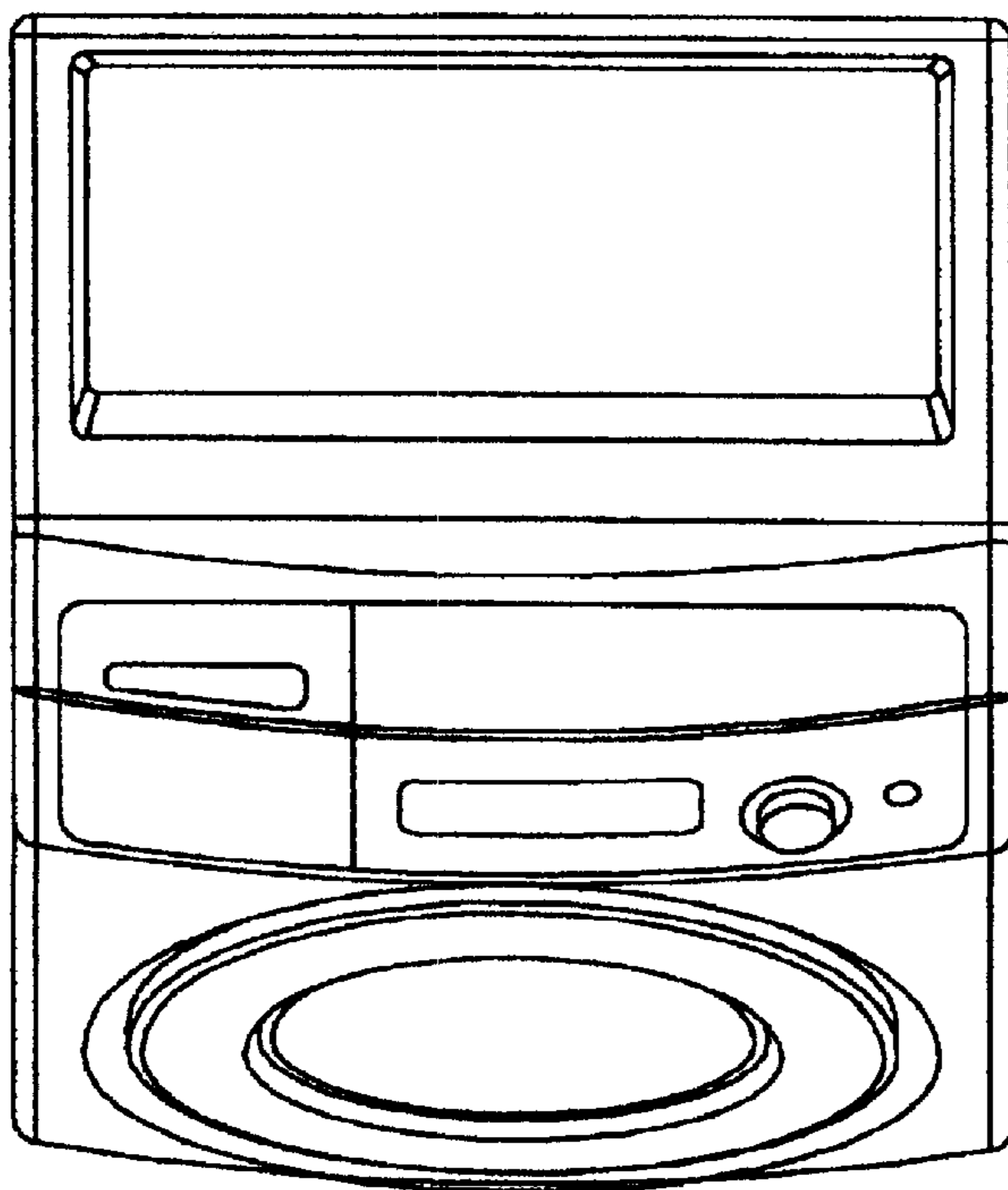

FIG. 7

