



US00D541192S

(12) **United States Design Patent**  
**Jokelainen**

(10) **Patent No.:** **US D541,192 S**

(45) **Date of Patent:** **\*\* Apr. 24, 2007**

(54) **ELEMENTS OF A FRONT FAIRING FOR A SNOWMOBILE**

(75) Inventor: **Jari Jokelainen**, Rovaniemi (FI)

(73) Assignee: **BRP Finland Oy**, Rovaniemi (FI)

(\*\*) Term: **14 Years**

(21) Appl. No.: **29/222,764**

(22) Filed: **Feb. 2, 2005**

(51) **LOC (8) Cl.** ..... **12-14**

(52) **U.S. Cl.** ..... **D12/7**

(58) **Field of Classification Search** ..... D12/7,  
D12/307, 400, 110, 111, 9, 112, 167, 171,  
D12/169, 196, 190, 90-92, 86, 85, 88; 280/645;  
D21/533; 180/182-86, 190

See application file for complete search history.

(56) **References Cited**

U.S. PATENT DOCUMENTS

D403,273 S	*	12/1998	Cadotte et al.	.....	D12/7
D493,390 S	*	7/2004	Sanschagrín et al.	.....	D12/7
D494,504 S	*	8/2004	Sanschagrín et al.	.....	D12/7
D494,505 S	*	8/2004	Sanschagrín et al.	.....	D12/7
D512,662 S	*	12/2005	Deluy	.....	D12/7
2006/0175106 A1	*	8/2006	Vaisanen	.....	180/190

\* cited by examiner

*Primary Examiner*—Louis S. Zarfás

*Assistant Examiner*—Anna K Dworzecka

(74) *Attorney, Agent, or Firm*—Osler, Hoskin & Harcourt LLP

(57) **CLAIM**

The ornamental design for elements of a front fairing for a snowmobile, as shown and described.

**DESCRIPTION**

FIG. 1 is a perspective illustration, from the rear and left side, of elements of a front fairing for a snowmobile according to my design;

FIG. 2 is a top plan view thereof;

FIG. 3 is a bottom plan view thereof;

FIG. 4 is a rear elevation view thereof;

FIG. 5 is a front elevation view thereof;

FIG. 6 is a left side elevation view thereof;

FIG. 7 is a right side elevation view thereof;

FIG. 8 is a perspective illustration from the front and right side, of elements of a front fairing for a snowmobile according to my new design shown on a snowmobile,

FIG. 9 is a top plan view thereof;

FIG. 10 is a bottom plan view thereof;

FIG. 11 is a rear elevation view thereof;

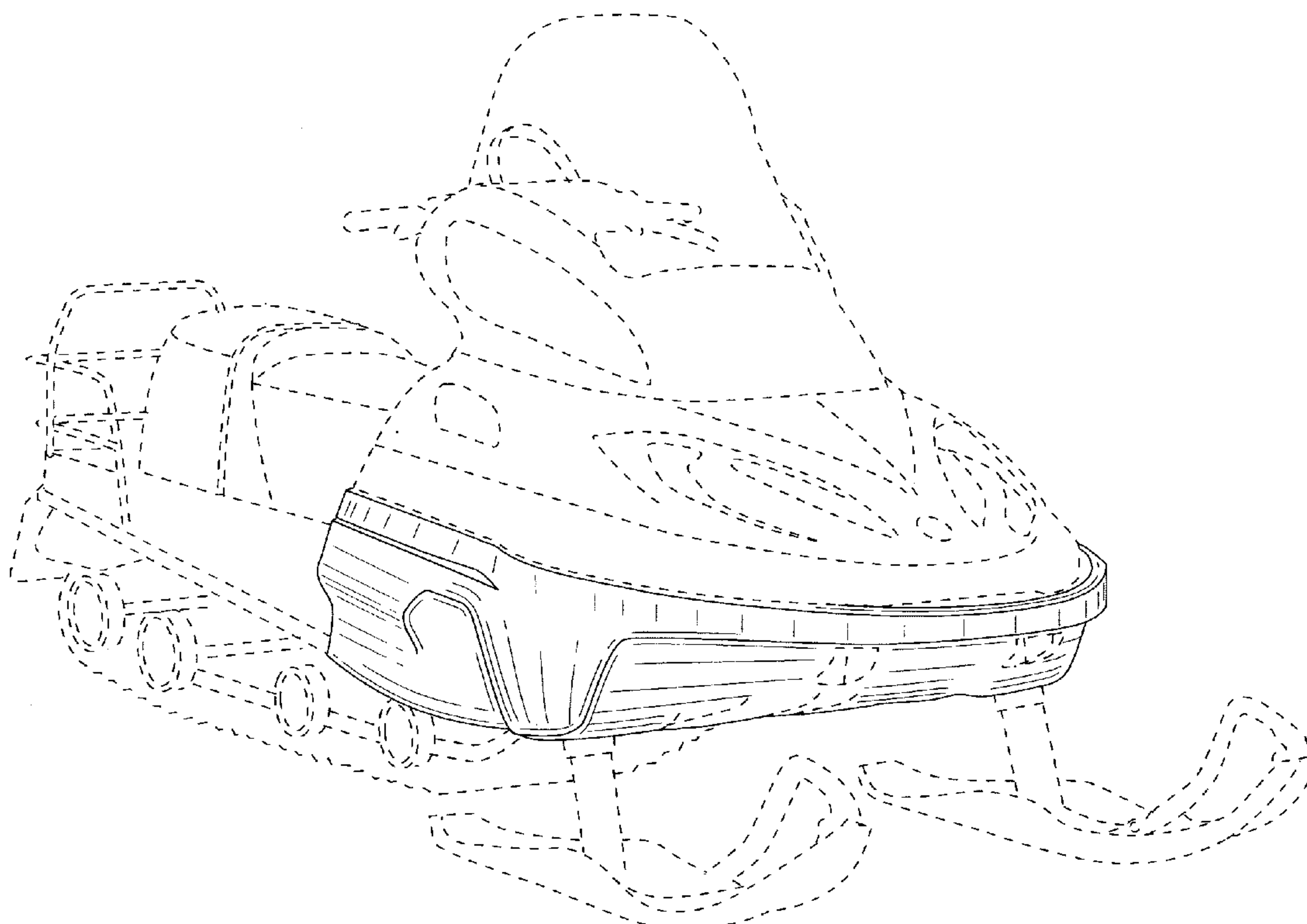
FIG. 12 is a front elevation view thereof;

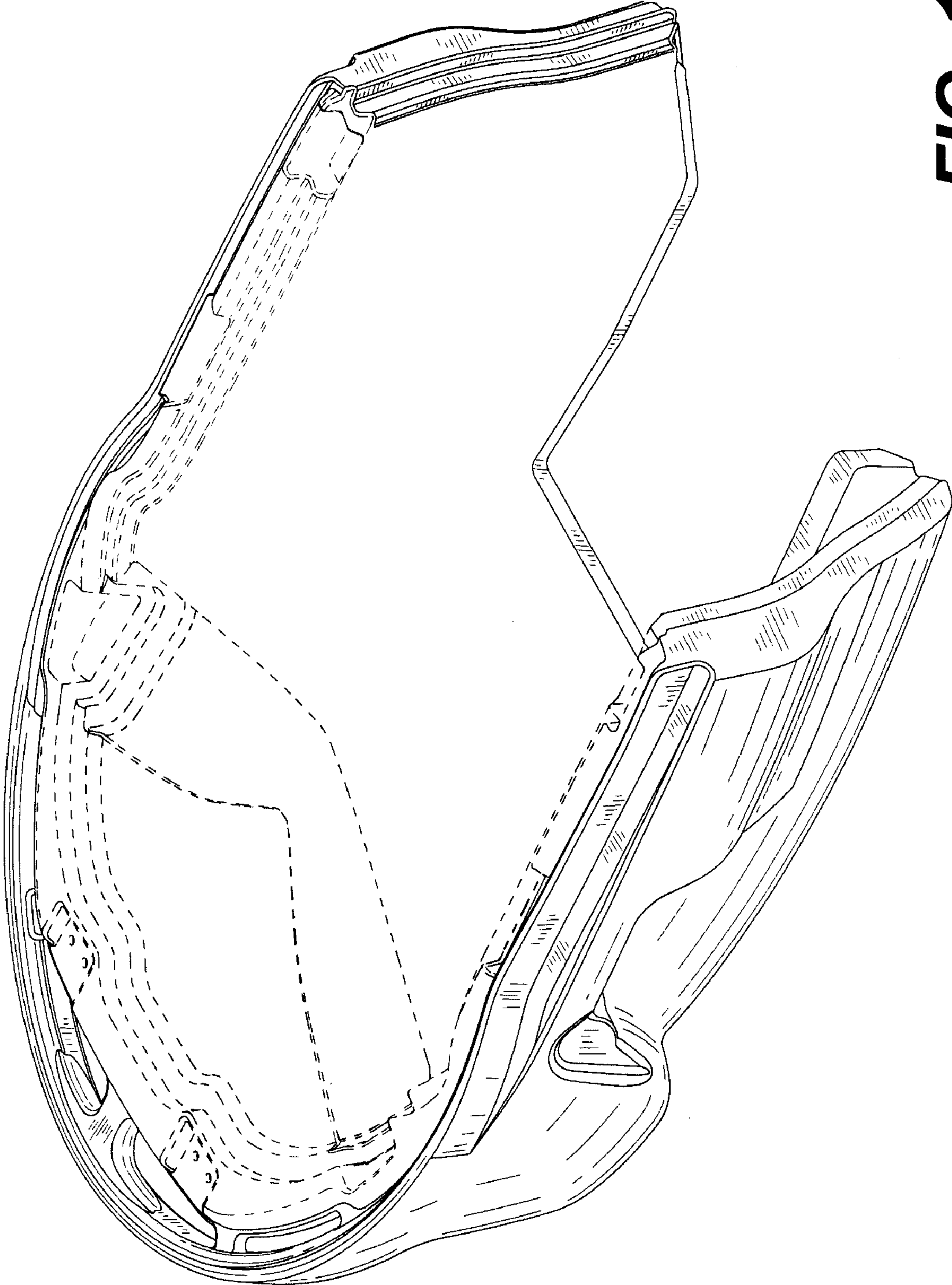
FIG. 13 is a left side elevation view thereof; and,

FIG. 14 is a right side elevation view.

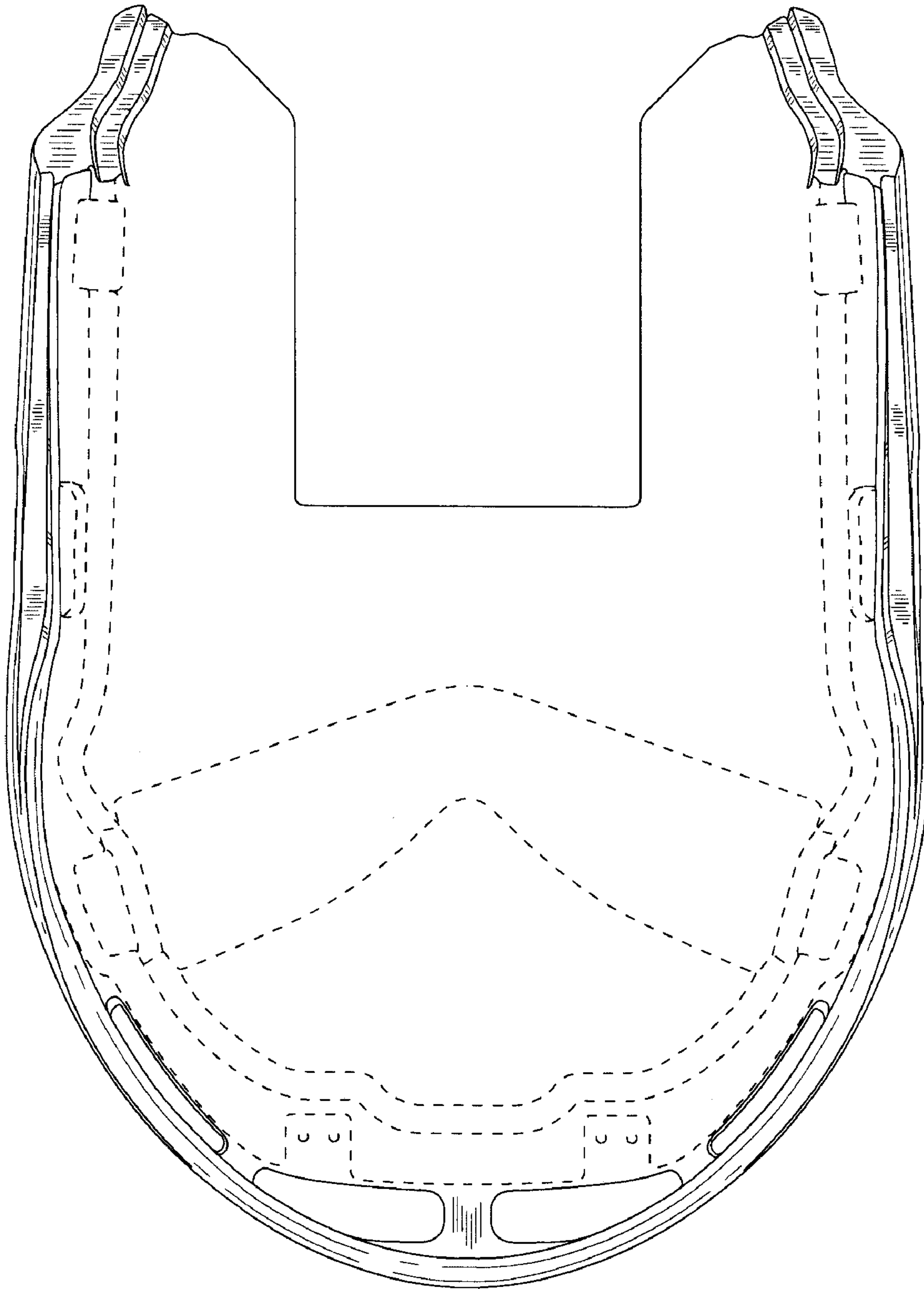
In FIGS. 1-14, broken lines showing structure are for illustrative purposes only and form no part of the claimed design.

**1 Claim, 11 Drawing Sheets**

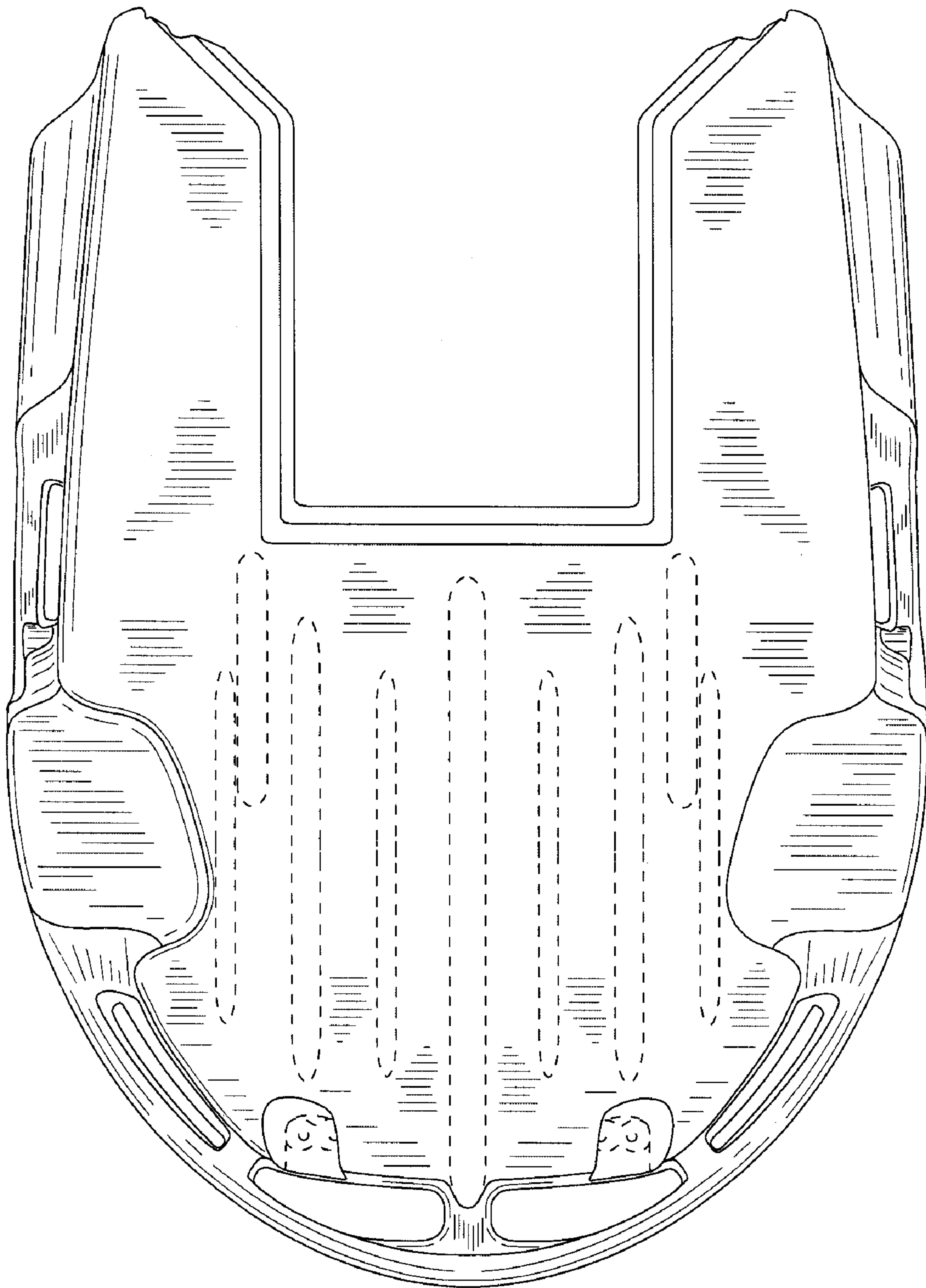




**FIG. 1**

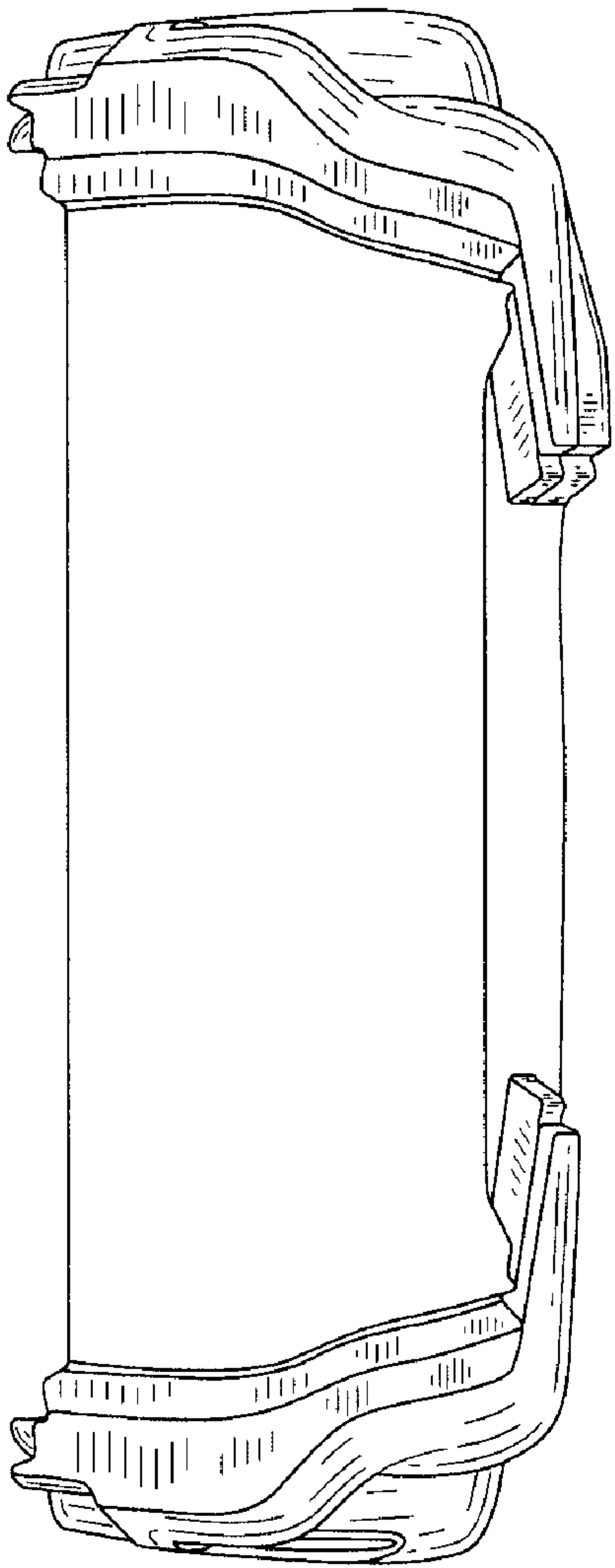


**FIG. 2**

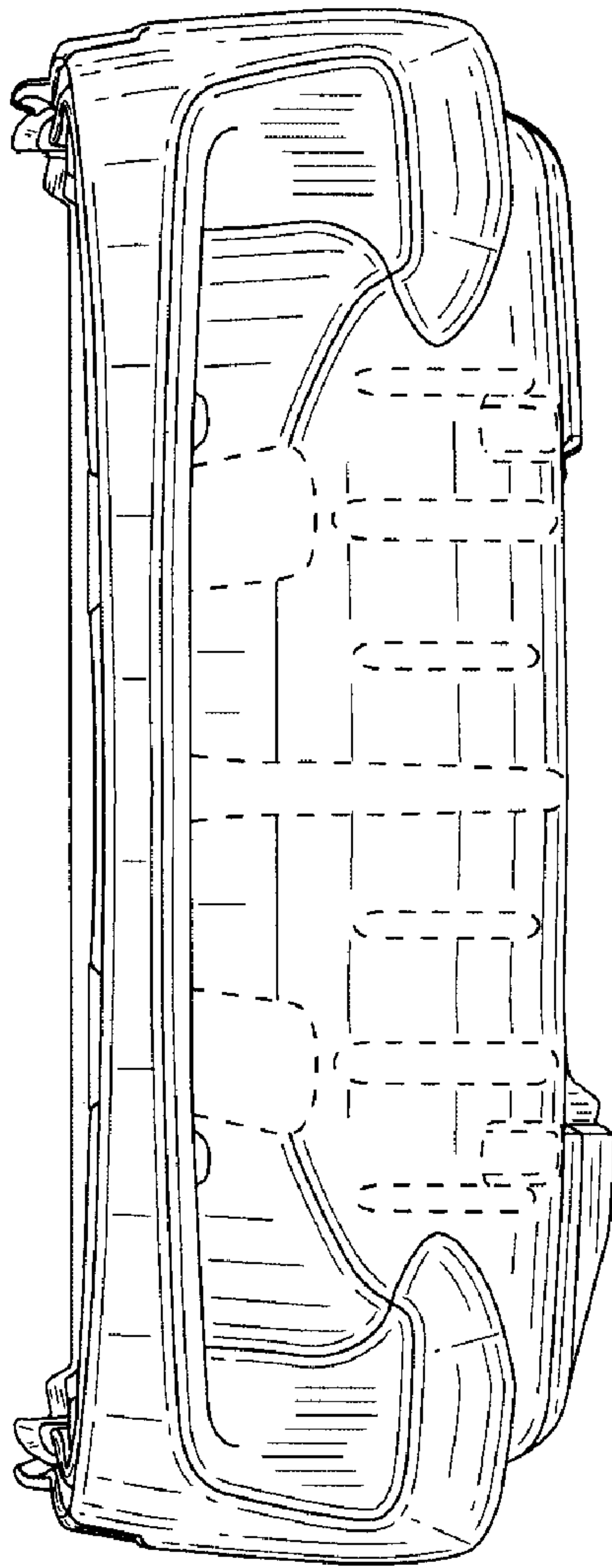


**FIG. 3**

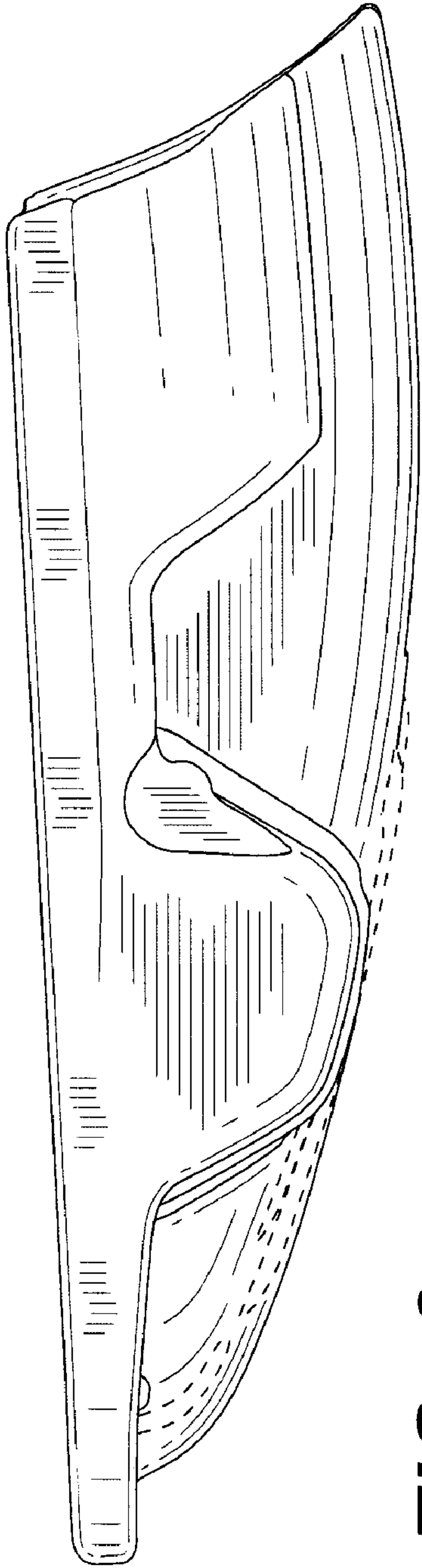




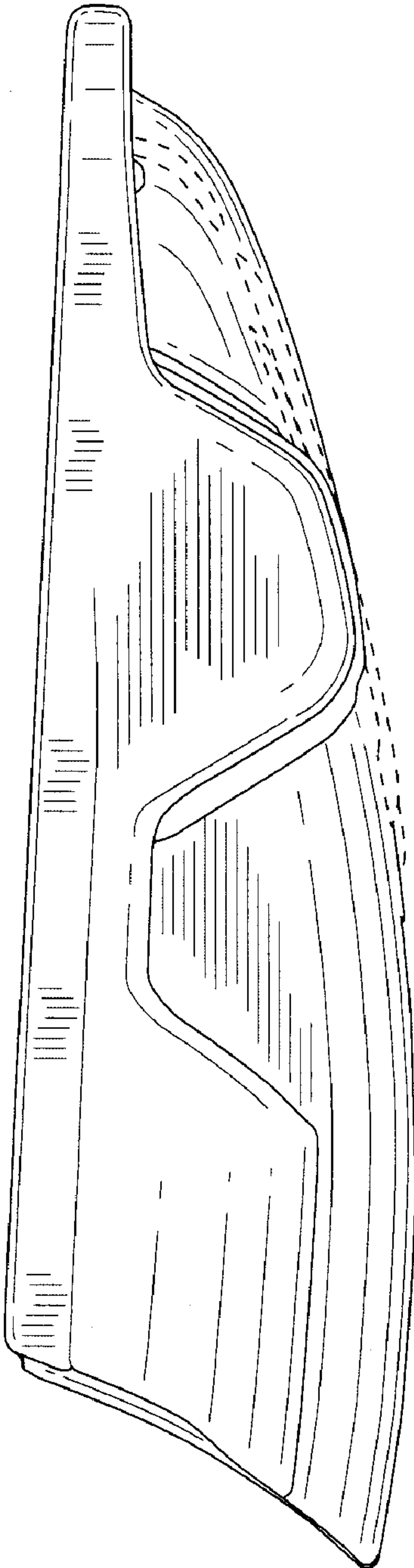
**FIG. 4**



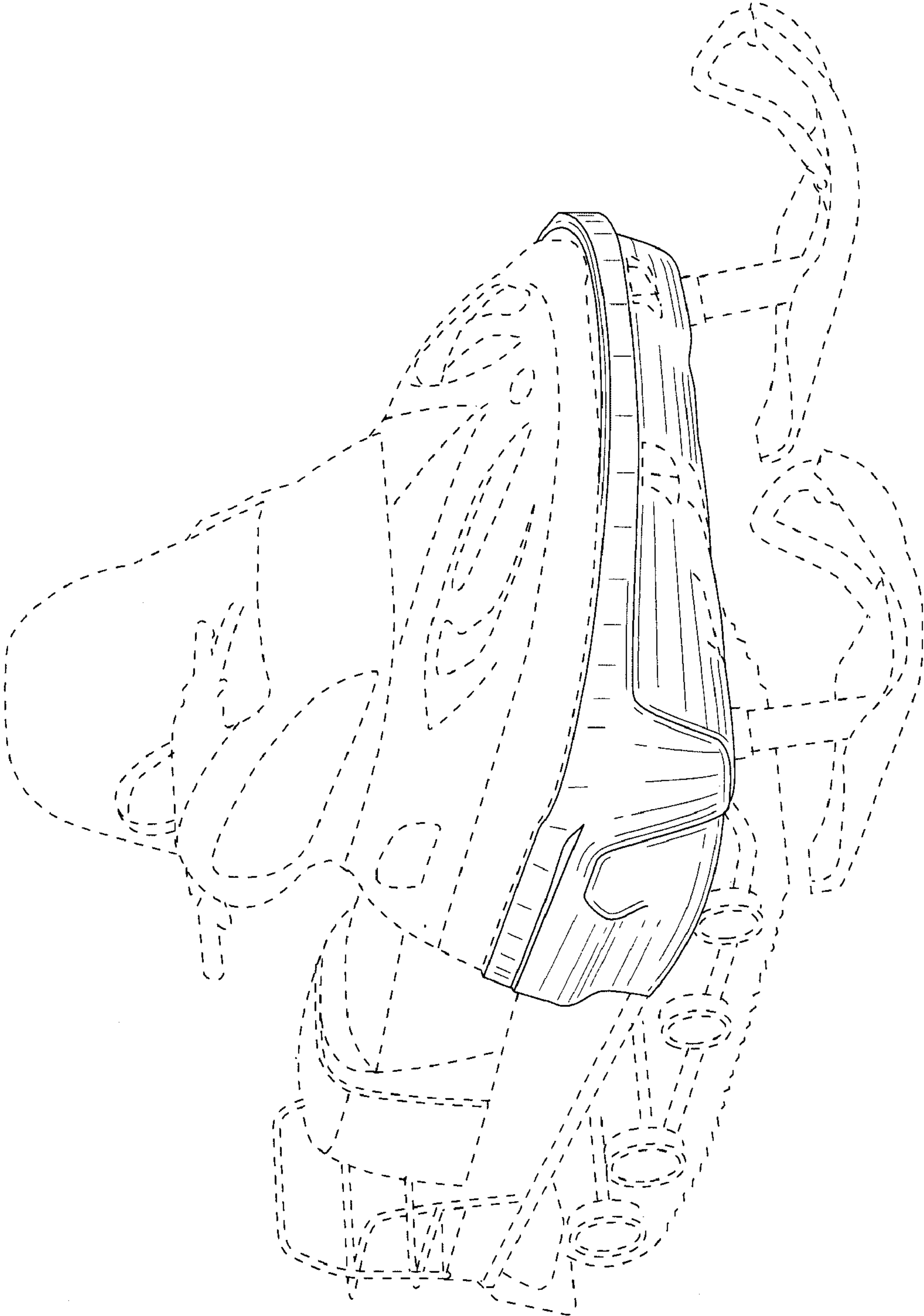
**FIG. 5**



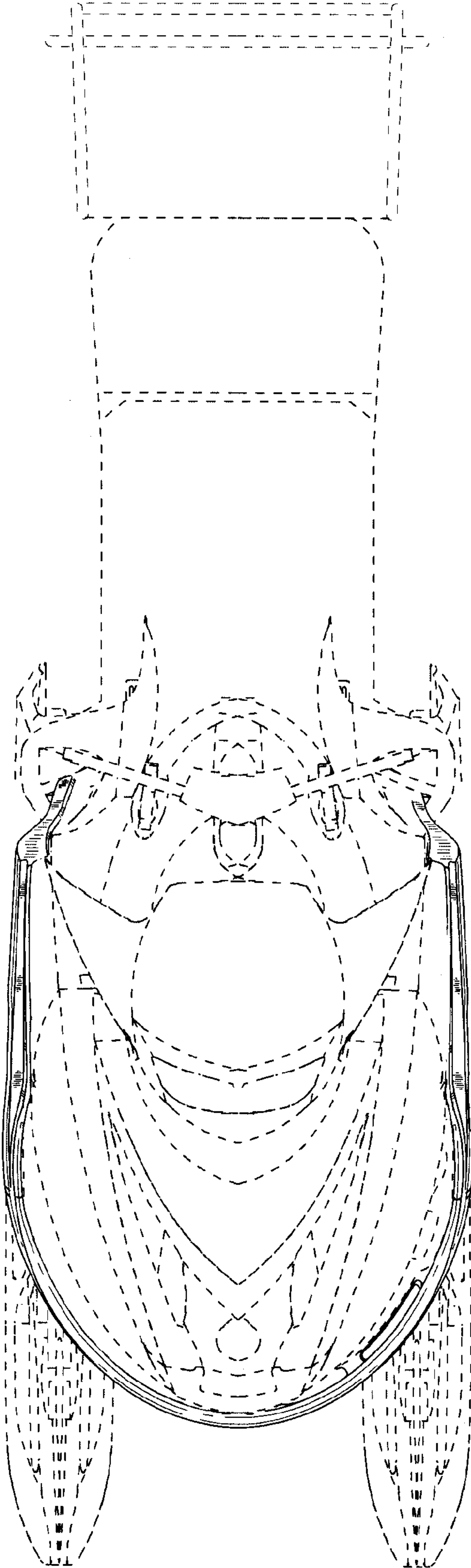
**FIG. 6**



**FIG. 7**

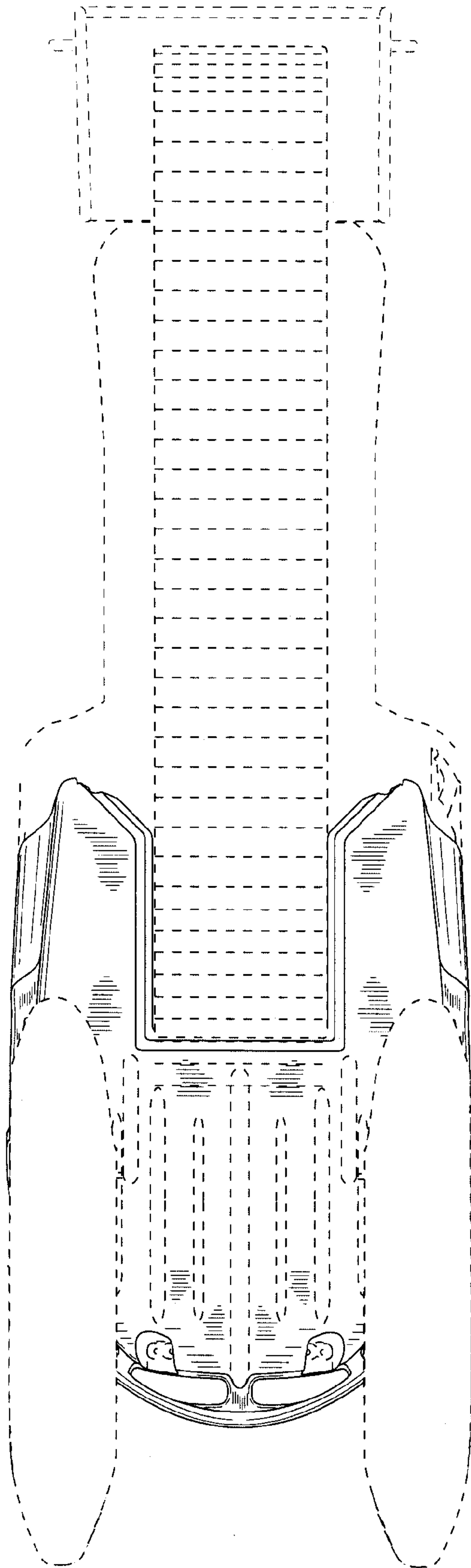


**FIG. 8**

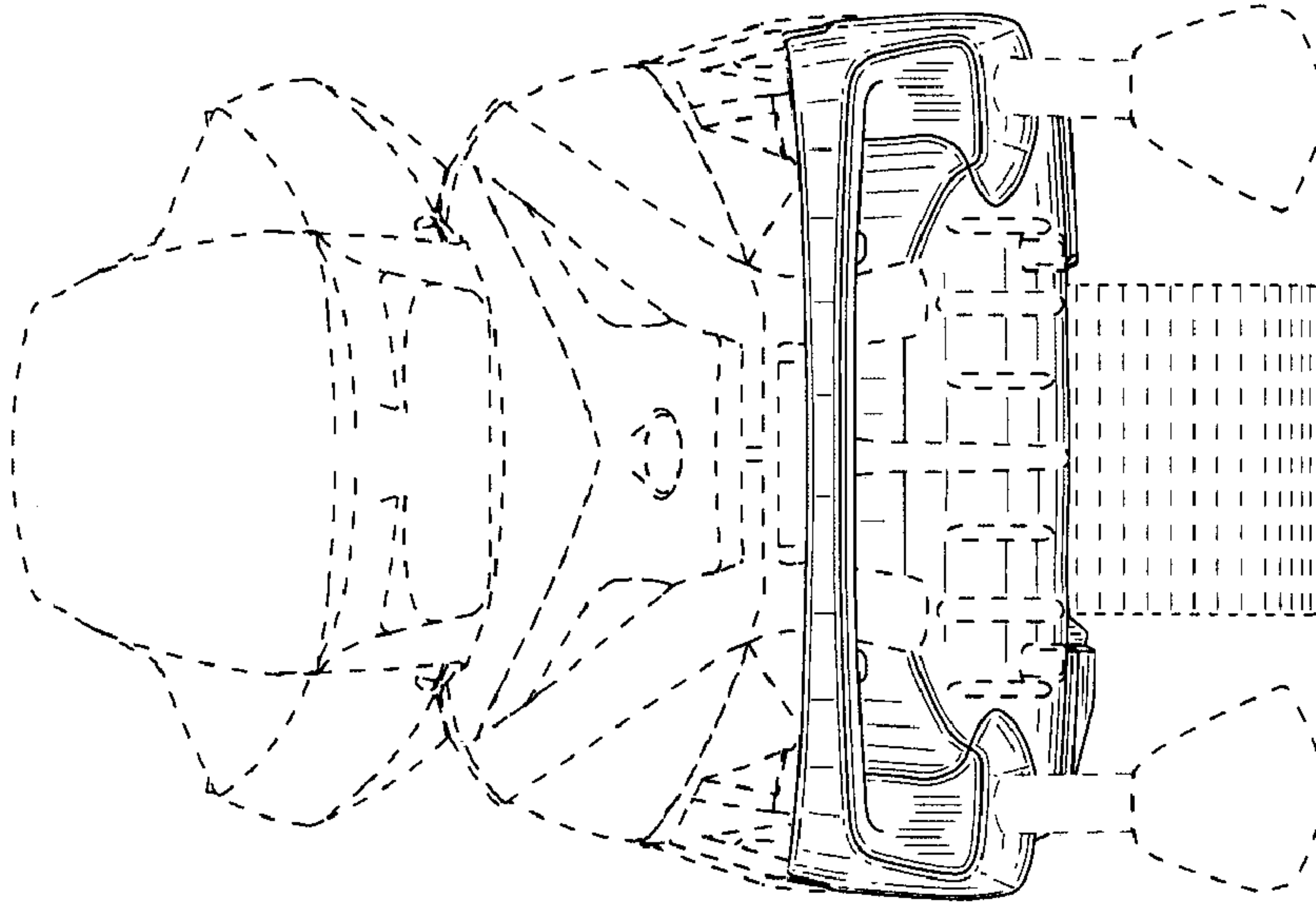


**FIG. 9**

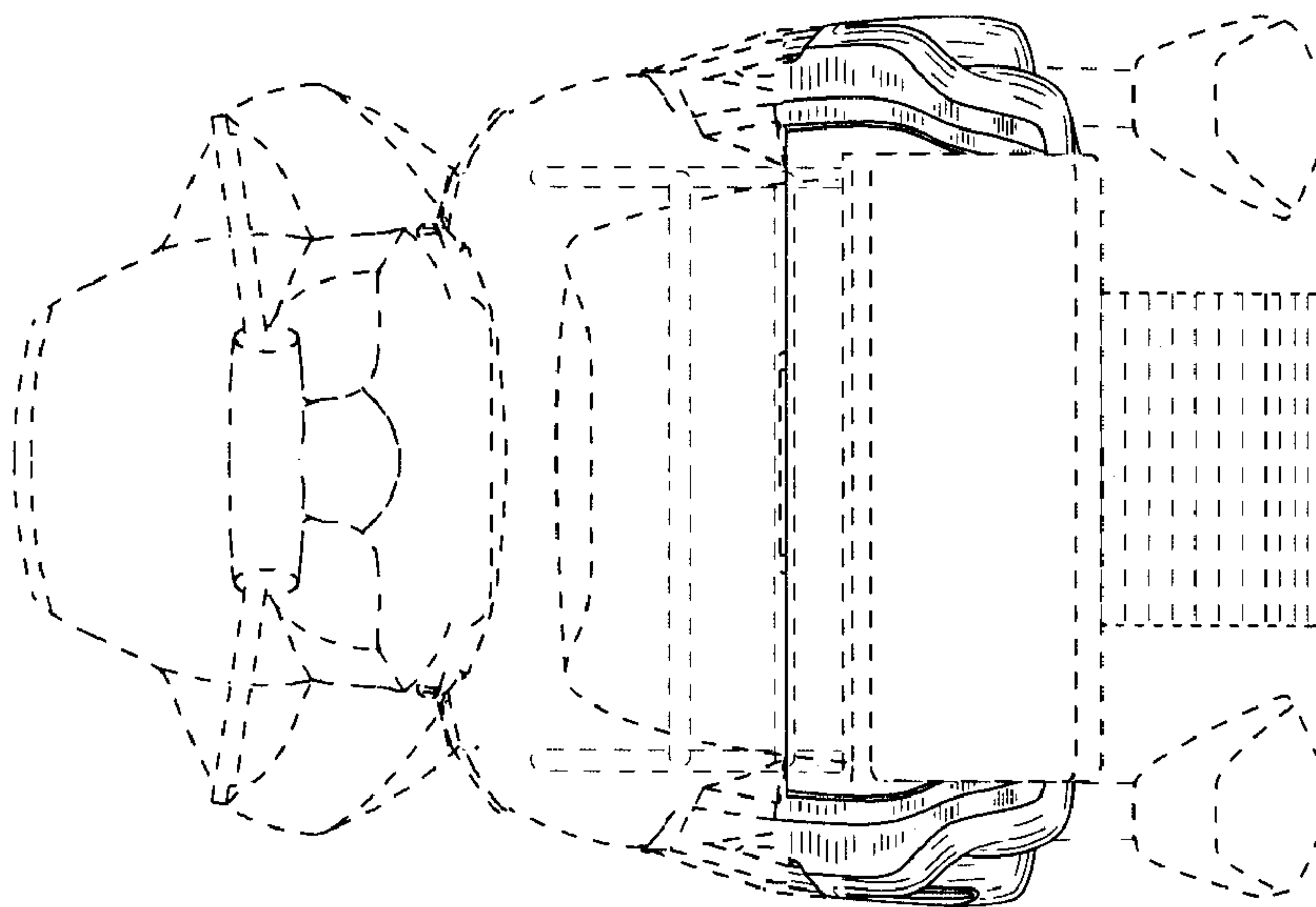




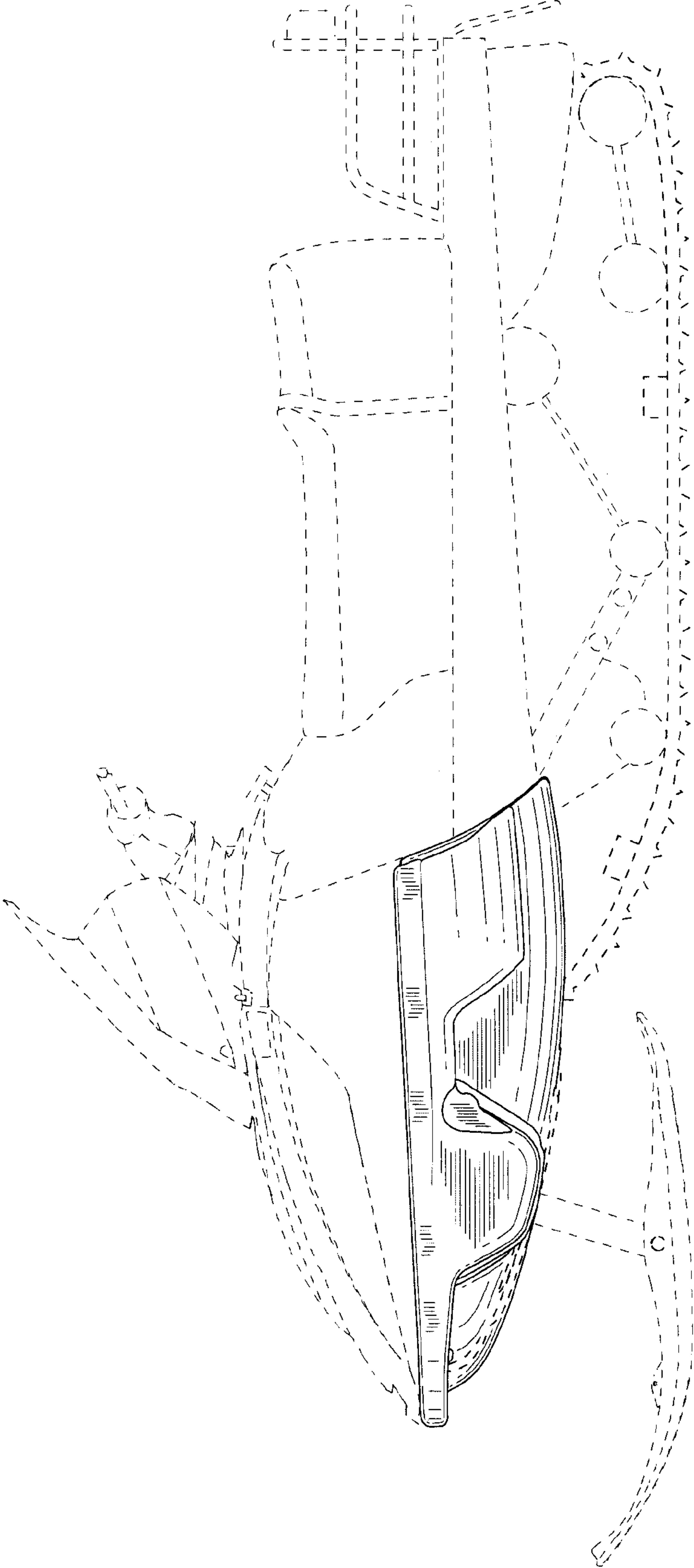
**FIG. 10**



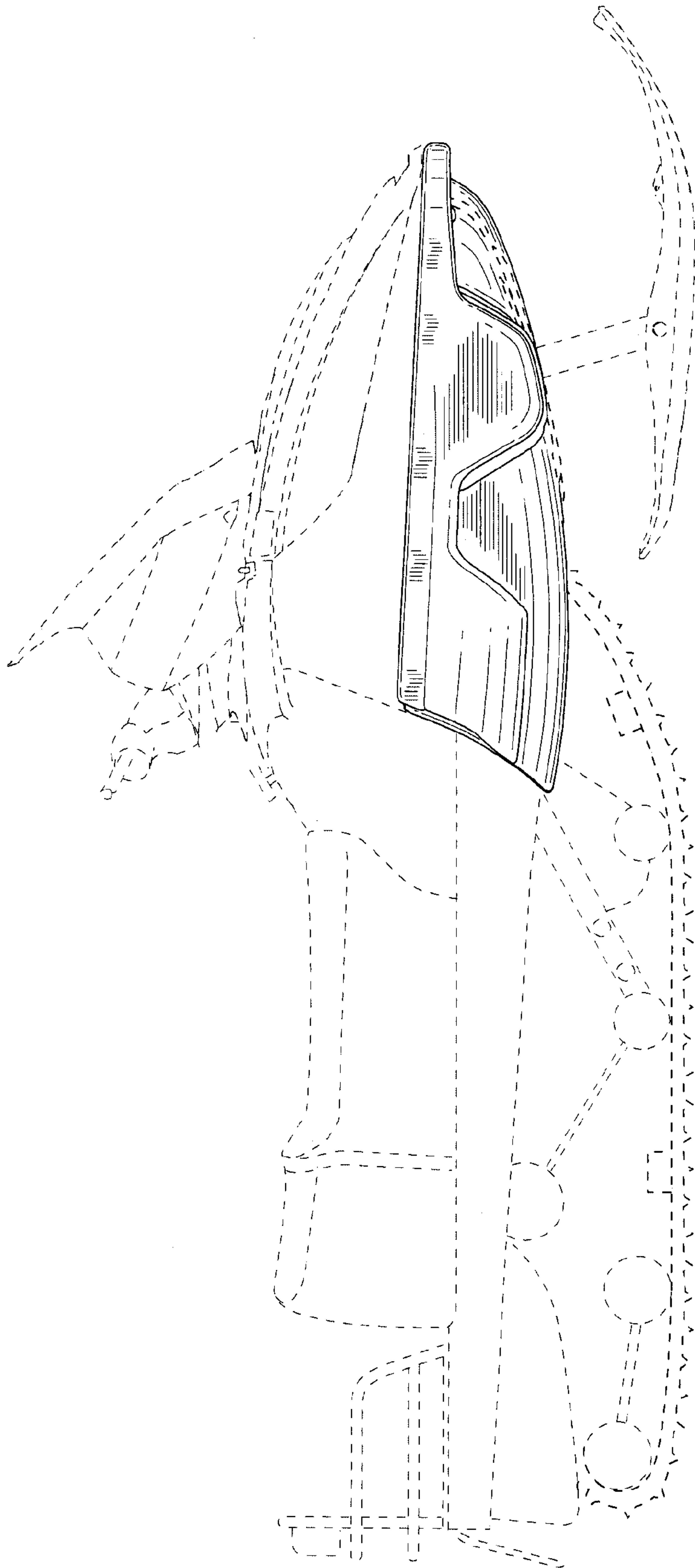
**FIG. 11**



**FIG. 12**



**FIG. 13**



**FIG. 14**