



US00D540921S

(12) **United States Design Patent**
Bruce

(10) **Patent No.:** **US D540,921 S**

(45) **Date of Patent:** **** Apr. 17, 2007**

(54) **SINK**

D394,496 S * 5/1998 Cuttriss D23/285
D464,128 S * 10/2002 Piano D23/293.1
D470,929 S * 2/2003 Kawamura et al. D23/293.1

(75) Inventor: **David Bruce**, Monroe Township, NJ
(US)

* cited by examiner

(73) Assignee: **Foremost Groups, Inc.**, East Hanover,
NJ (US)

Primary Examiner—Robert A. Delehanty
(74) *Attorney, Agent, or Firm*—Drinker Biddle & Reath
LLP

(**) Term: **14 Years**

(57) **CLAIM**

(21) Appl. No.: **29/227,081**

The ornamental design for a sink, as shown and described.

(22) Filed: **Apr. 6, 2005**

DESCRIPTION

(51) **LOC (8) Cl.** **23-02**

(52) **U.S. Cl.** **D23/293.1**

(58) **Field of Classification Search** D23/270–271,
D23/273, 284–287, 291, 293.1, 303, 308;
4/619, 624–625, 630, 661, DIG. 15; D21/524
See application file for complete search history.

FIG. 1 is front elevation view showing my new design.
FIG. 2 is a rear elevation view of the sink of FIG. 1.
FIG. 3 is a right side elevation view of the sink of FIG. 1,
the left side elevation view being a mirror-image.
FIG. 4 is a top plan view of the sink of FIG. 1; and,
FIG. 5 is a bottom plan view of the sink of FIG. 1.
The portions of the drawings appearing in broken lines are
for environment only and do not form a part of the claimed
design.

(56) **References Cited**

U.S. PATENT DOCUMENTS

D267,336 S * 12/1982 Fortuno D23/293.1
D281,449 S * 11/1985 Stairs, Jr. D23/293.1

1 Claim, 3 Drawing Sheets

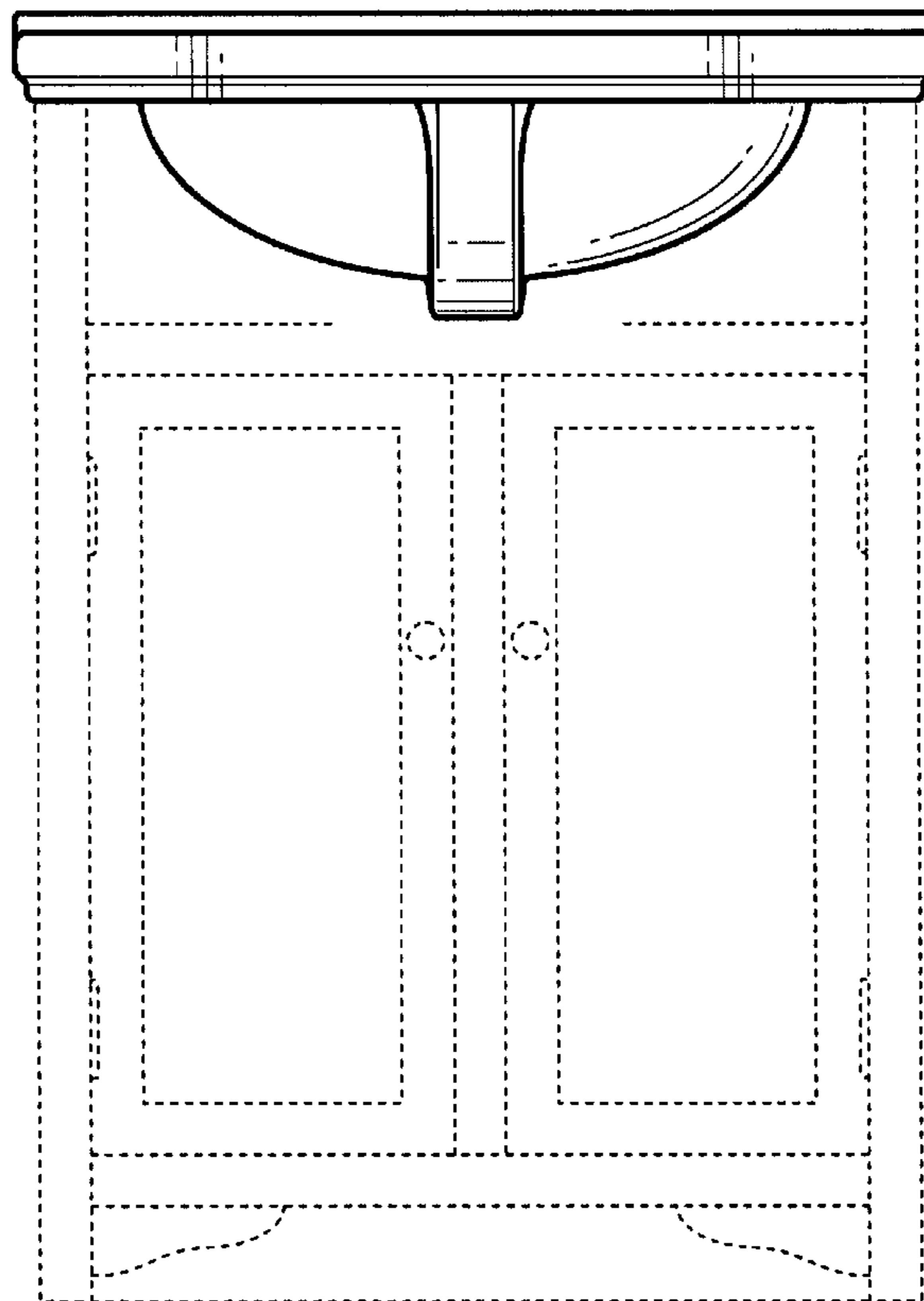

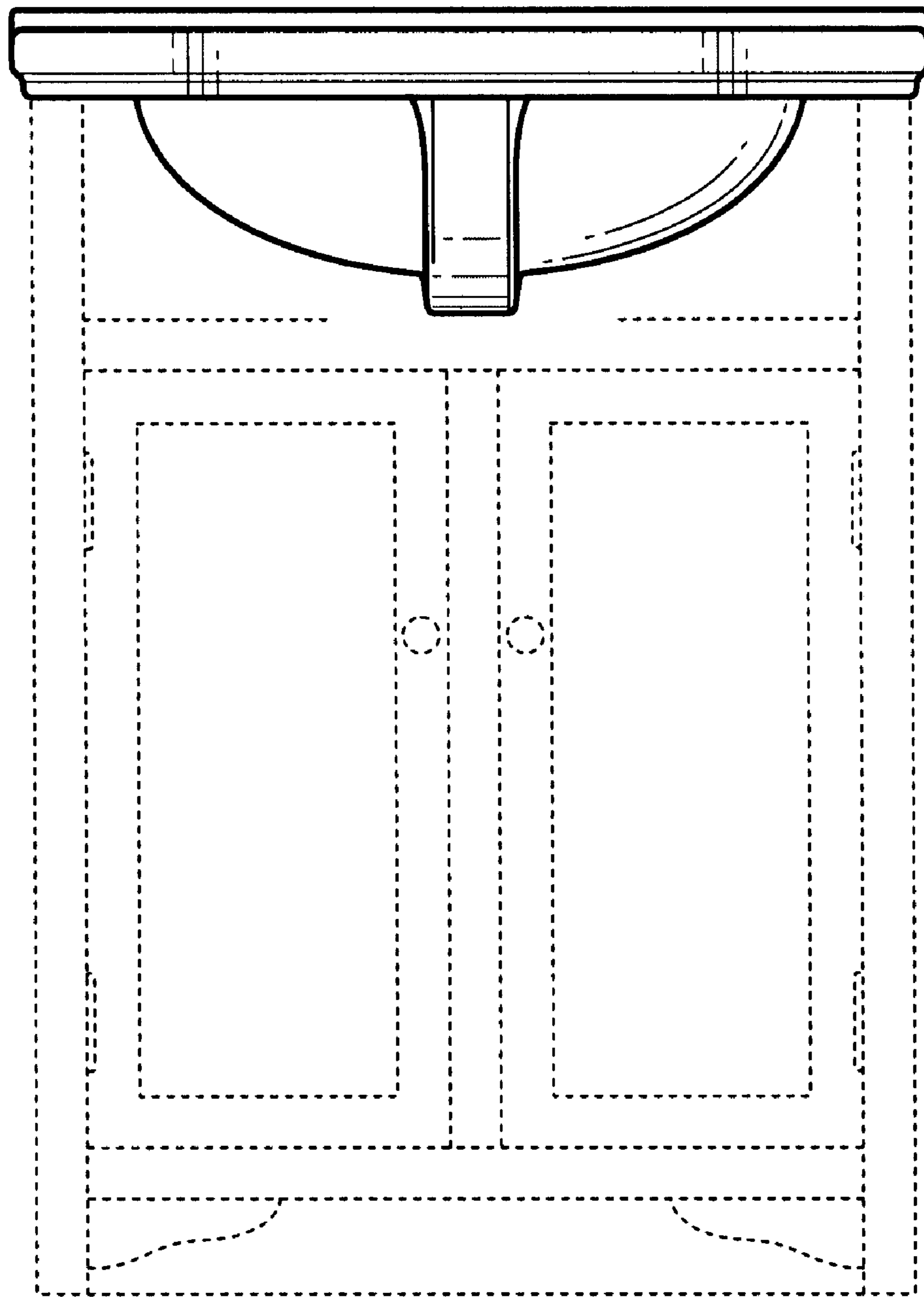

FIG. 1

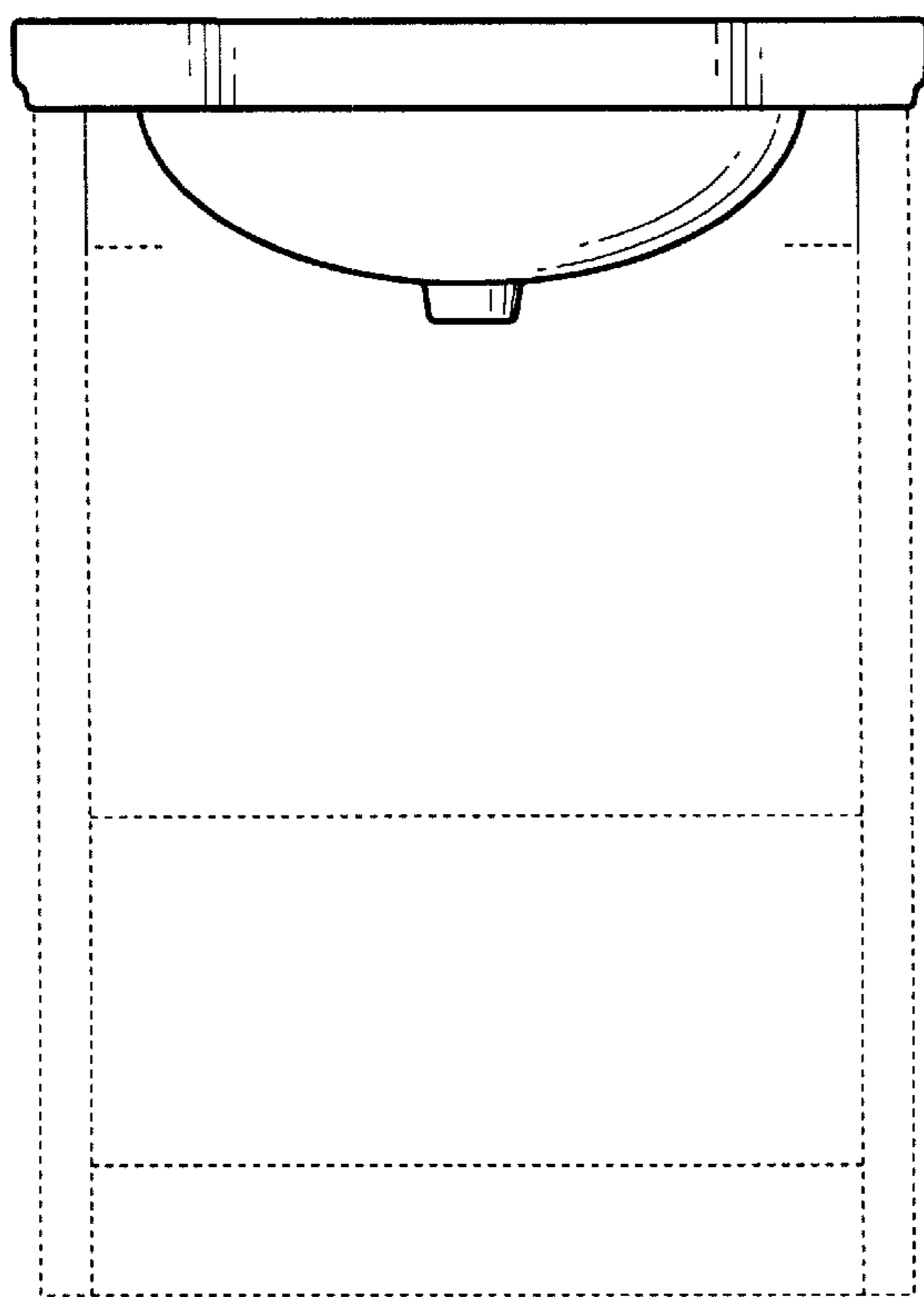

FIG. 2

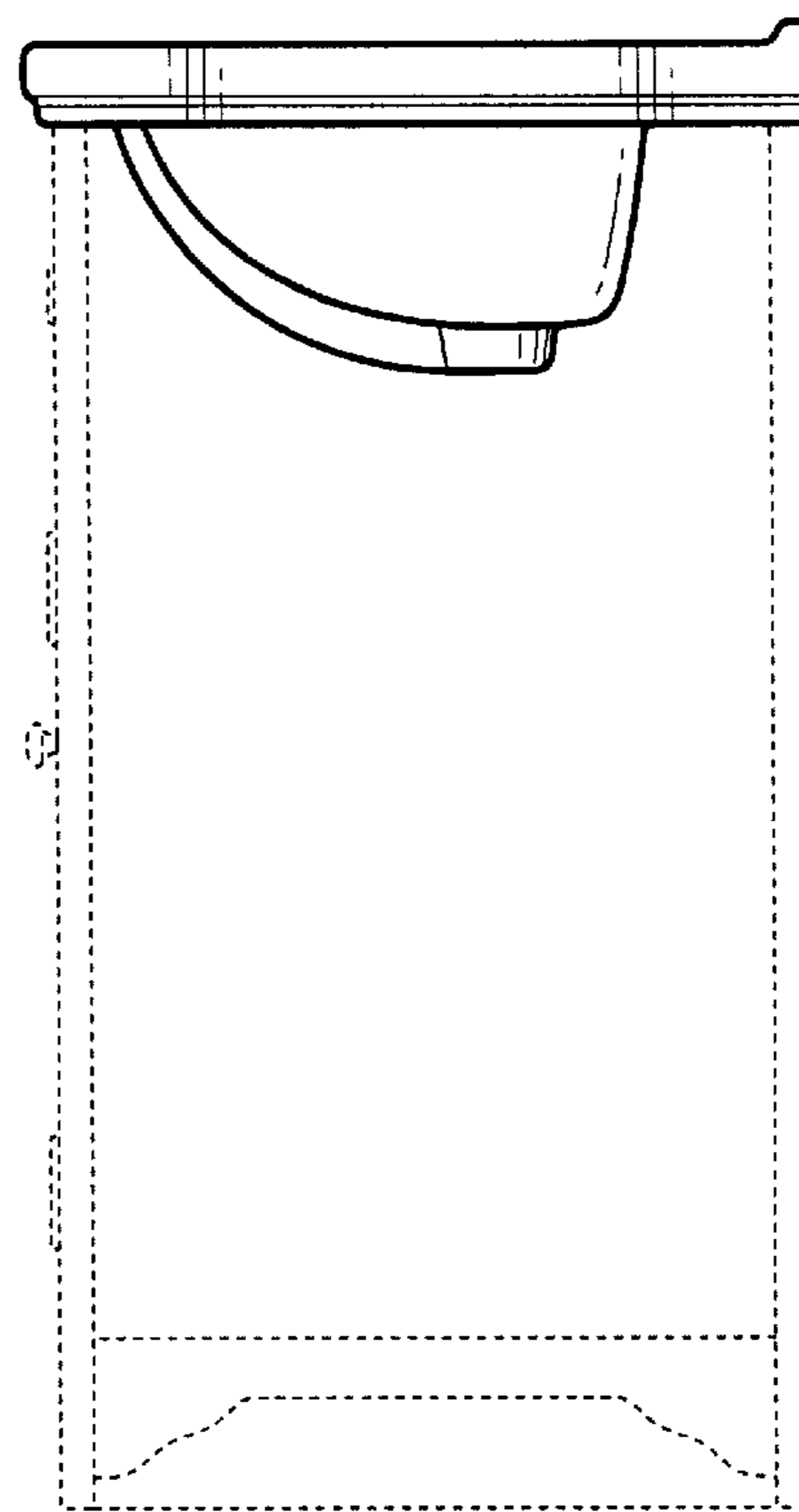

FIG. 3

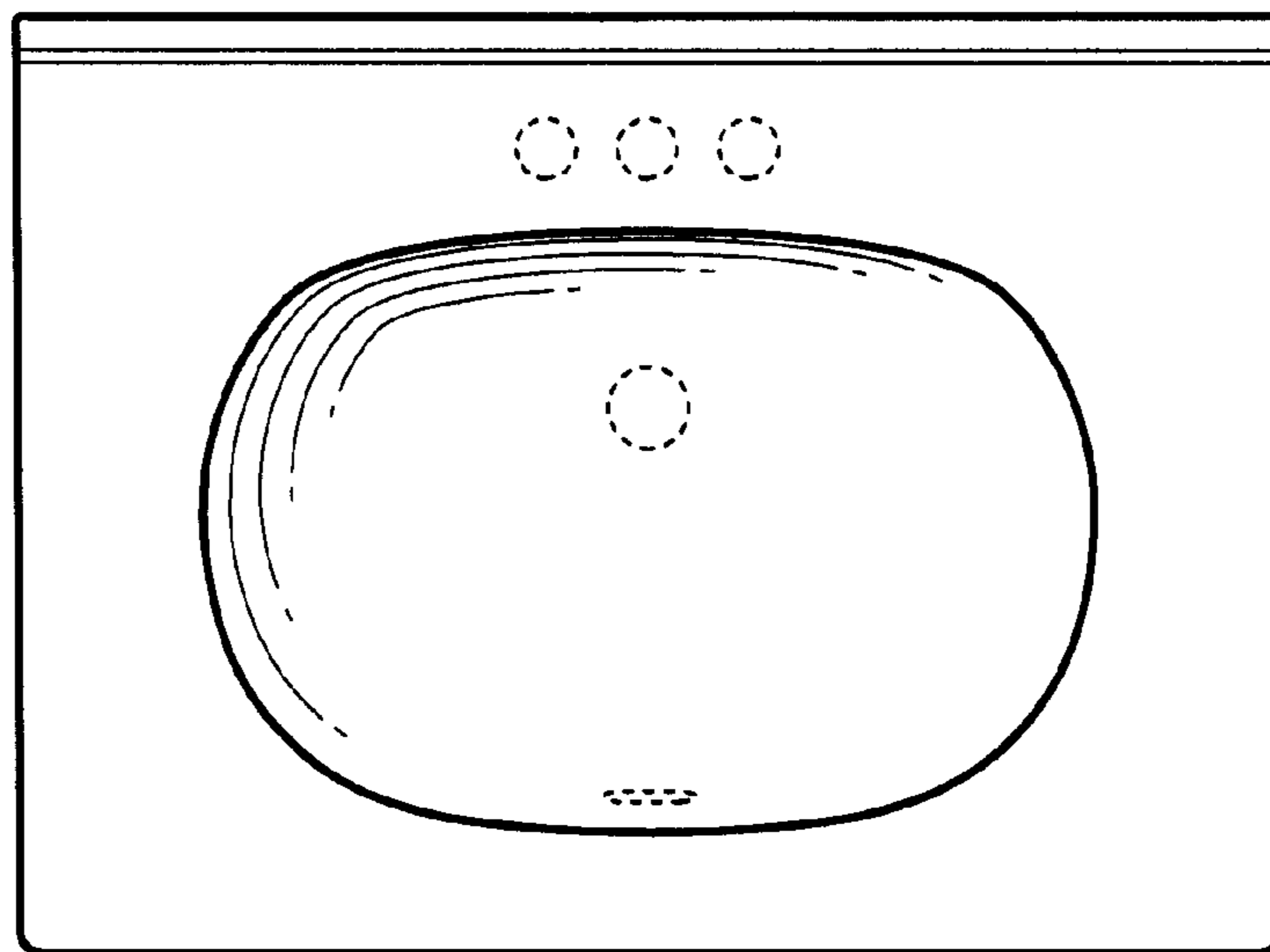

FIG. 4

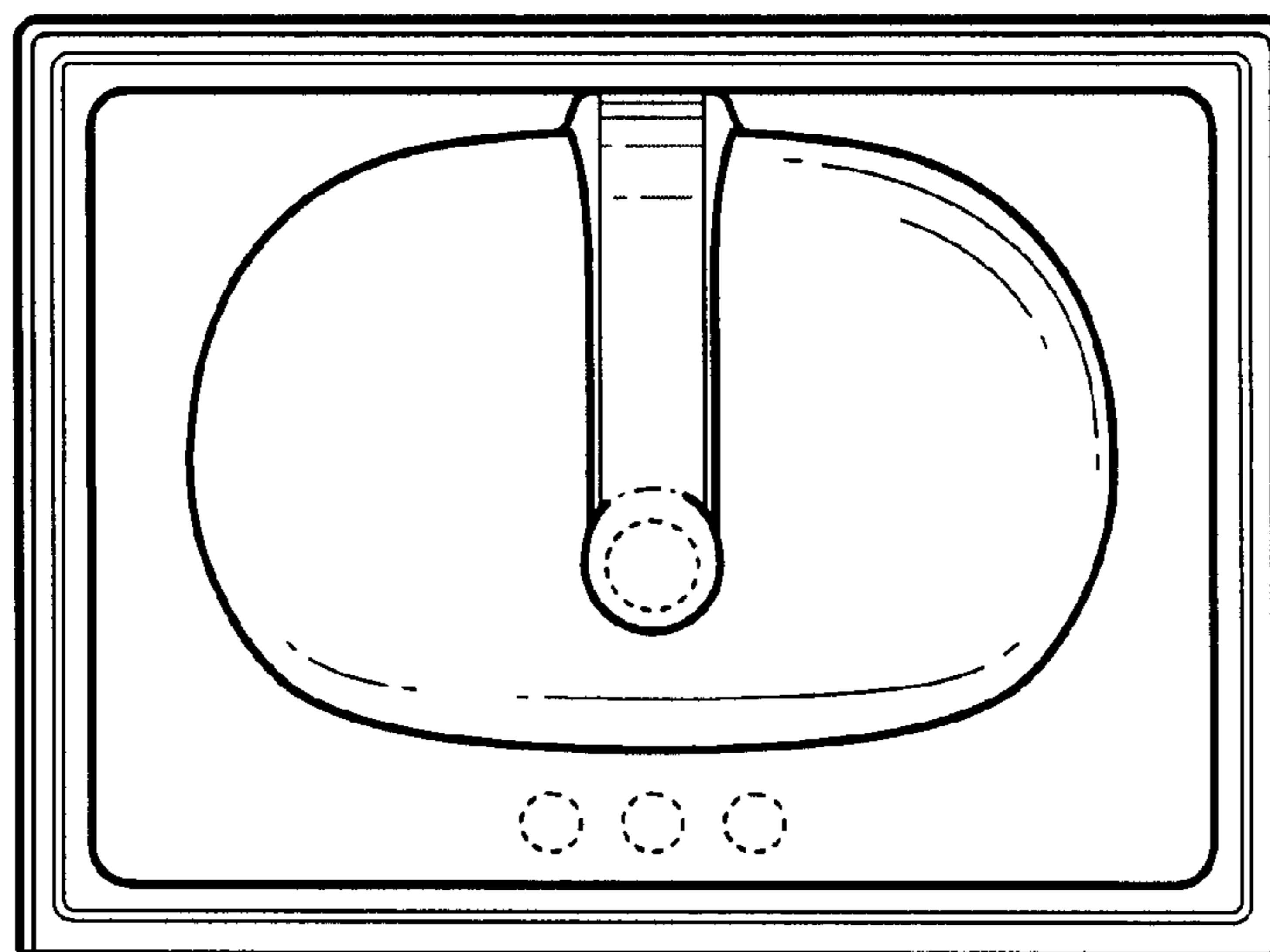

FIG. 5