



US00D540746S

(12) **United States Design Patent**  
**Watanabe et al.**

(10) **Patent No.:** **US D540,746 S**

(45) **Date of Patent:** **\*\* Apr. 17, 2007**

(54) **ELECTRICAL CONNECTOR**

(75) Inventors: **Tsuneki Watanabe**, Yokohama (JP);  
**Gwou-Jong Tseng**, Tu-Cheng (TW);  
**Meng-Huan Yang**, Tu-Cheng (TW)

(73) Assignee: **Hon Hai Precision Ind. Co., Ltd.**,  
Taipei Hsien (TW)

(\*\*) **Term:** **14 Years**

(21) **Appl. No.:** **29/259,284**

(22) **Filed:** **May 5, 2006**

(30) **Foreign Application Priority Data**

Dec. 5, 2005 (TW) ..... 94307394

(51) **LOC (8) Cl.** ..... **13-03**

(52) **U.S. Cl.** ..... **D13/147**

(58) **Field of Classification Search** ..... D13/123,  
D13/133, 146-147, 154, 184, 199; 439/79,  
439/108, 278, 374, 377, 660, 607-610, 680,  
439/682, 883, 891, 894

See application file for complete search history.

(56) **References Cited**

**U.S. PATENT DOCUMENTS**

D427,567 S \* 7/2000 Nishio et al. .... D13/147  
D446,773 S \* 8/2001 Yao et al. .... D13/147  
D450,302 S \* 11/2001 Shimojyo ..... D13/147  
D462,326 S \* 9/2002 Okamoto ..... D13/147

D462,663 S \* 9/2002 Hagiwara ..... D13/147  
D465,202 S \* 11/2002 Kubota ..... D13/147  
D476,954 S \* 7/2003 Nishio et al. .... D13/147  
D478,050 S \* 8/2003 Nishio et al. .... D13/147  
D482,658 S \* 11/2003 Shao ..... D13/147  
D499,382 S \* 12/2004 Zhu et al. .... D13/147  
D503,682 S \* 4/2005 Tanaka et al. .... D13/147  
D507,780 S \* 7/2005 Wang ..... D13/147  
D509,190 S \* 9/2005 Tsai ..... D13/147  
D509,192 S \* 9/2005 Chen ..... D13/147  
D509,799 S \* 9/2005 Tsai ..... D13/147  
D523,400 S \* 6/2006 Shang-Yen et al. .... D13/147  
D523,817 S \* 6/2006 Nishio et al. .... D13/147

\* cited by examiner

*Primary Examiner*—Daniel Bui

(74) *Attorney, Agent, or Firm*—We Te Chung

(57) **CLAIM**

The ornamental design for an electrical connector, as shown and described.

**DESCRIPTION**

FIG. 1 is a front, top and right side perspective view of an electrical connector showing our new design; FIG. 2 is a front elevational view thereof; FIG. 3 is a rear elevational view thereof; FIG. 4 is a left side elevational view thereof; FIG. 5 is a right side elevational view thereof; FIG. 6 is a top plan view thereof; and, FIG. 7 is a bottom plan view thereof.

**1 Claim, 7 Drawing Sheets**

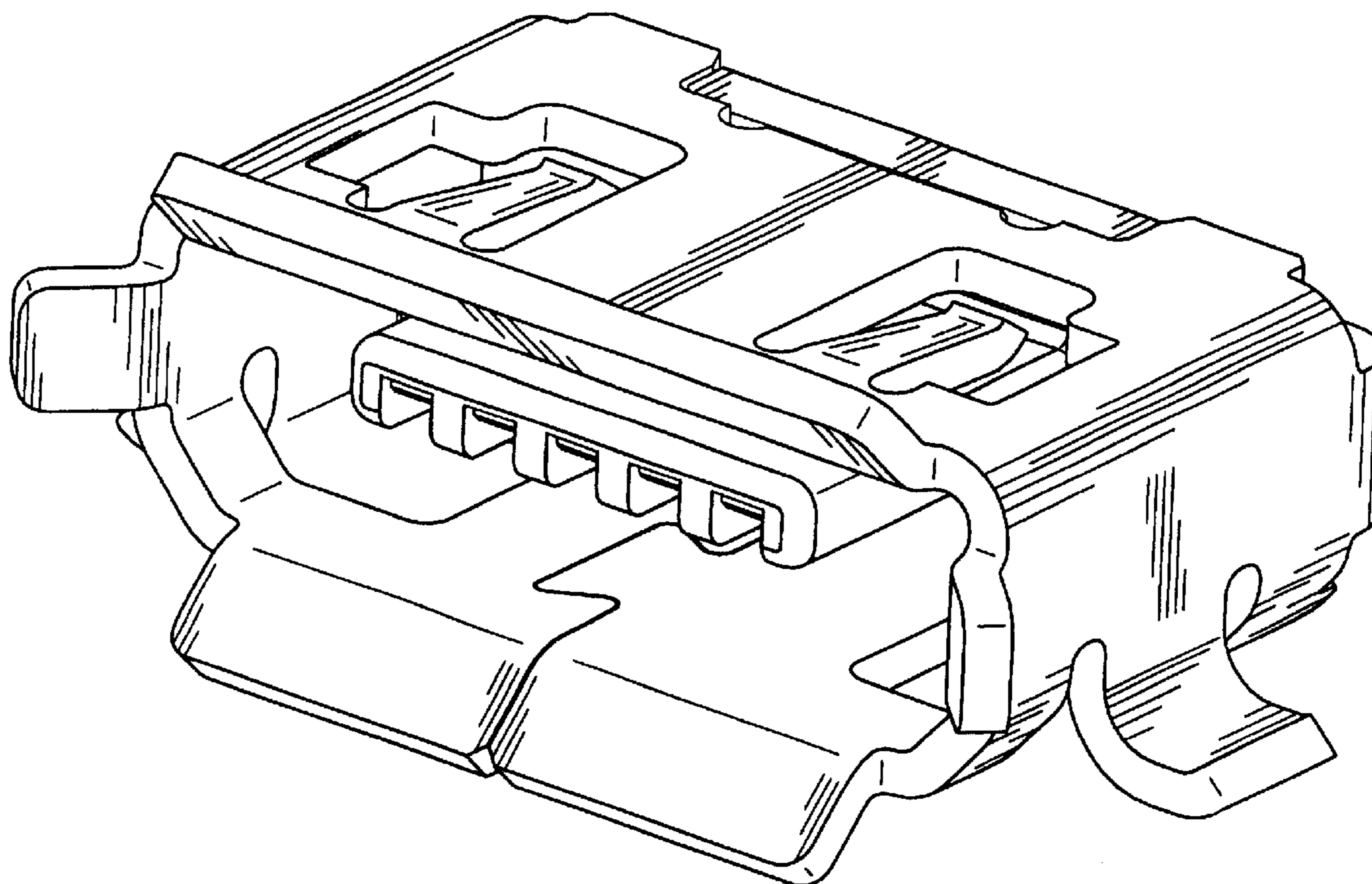

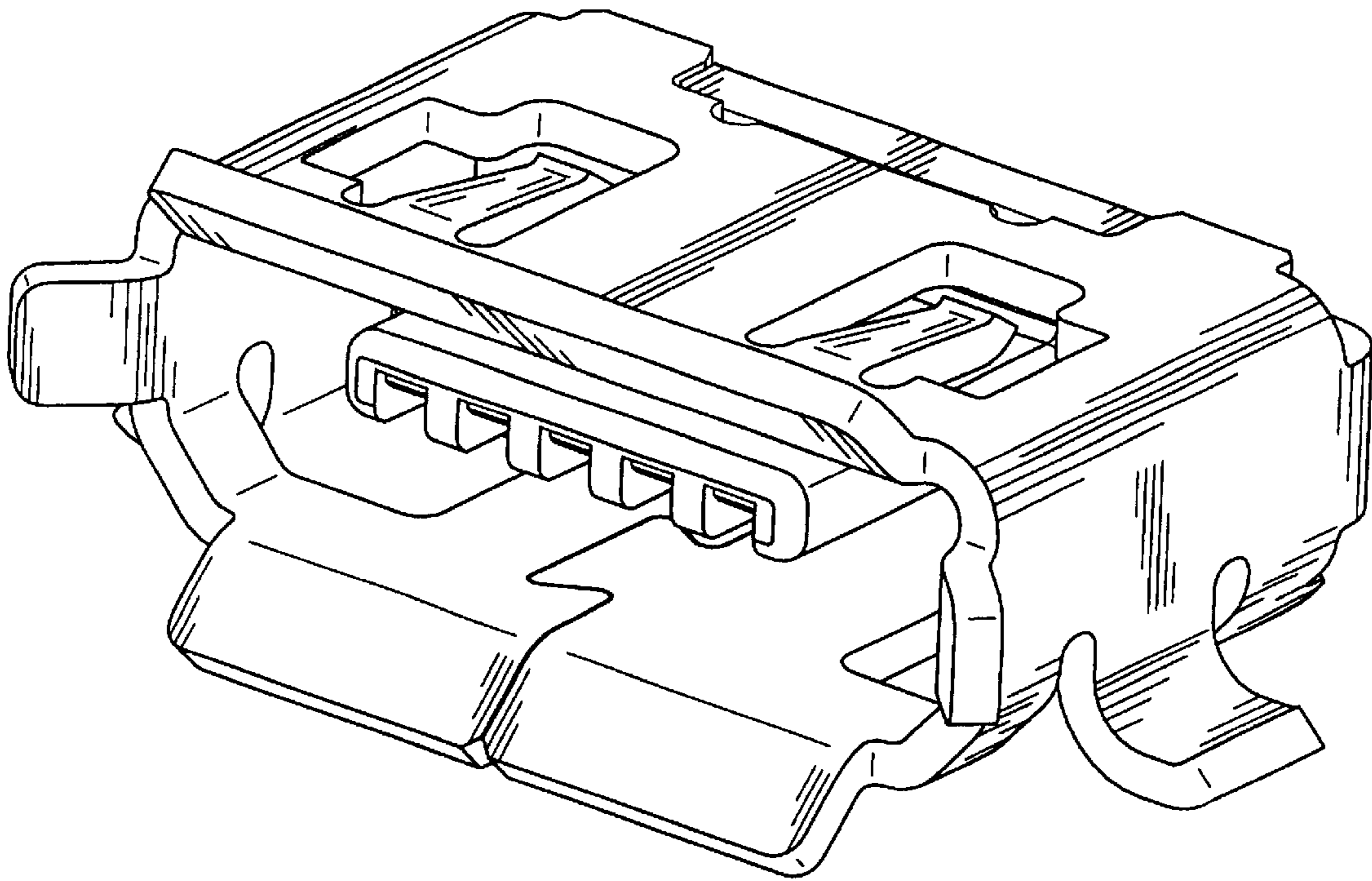

FIG. 1

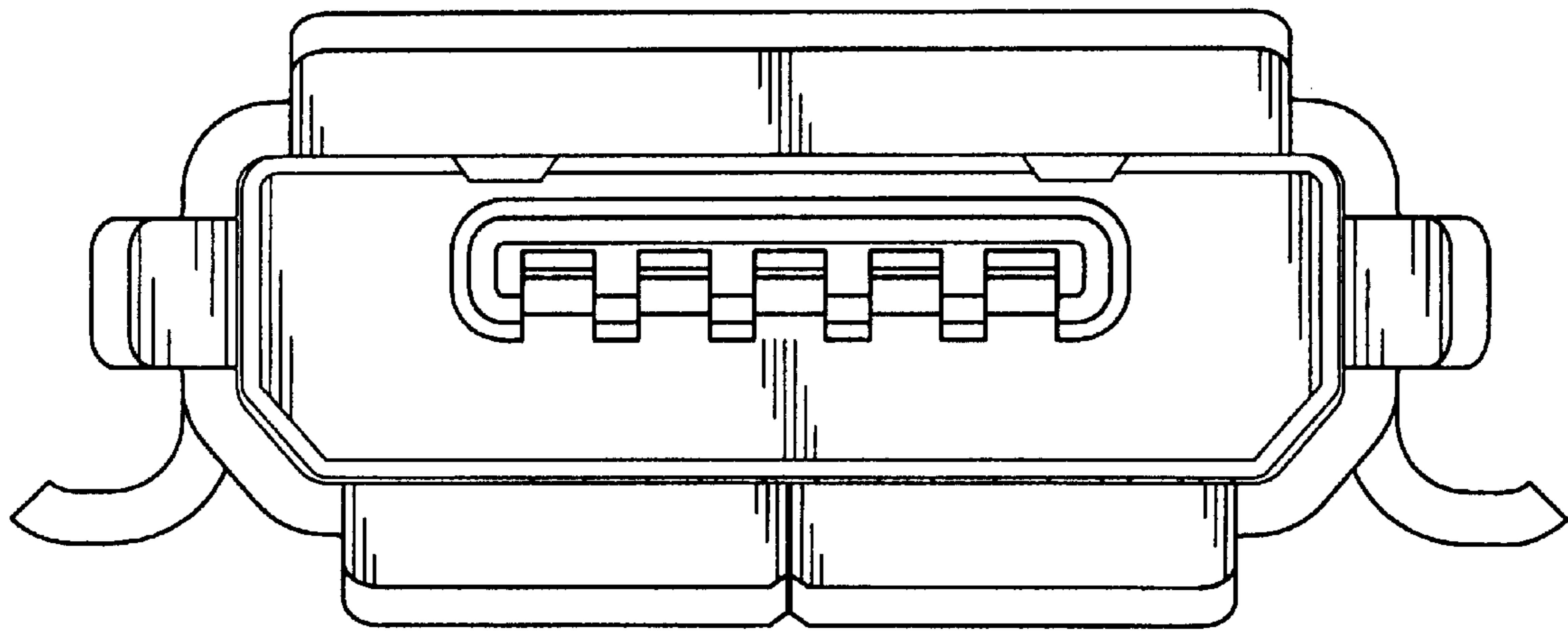

FIG. 2

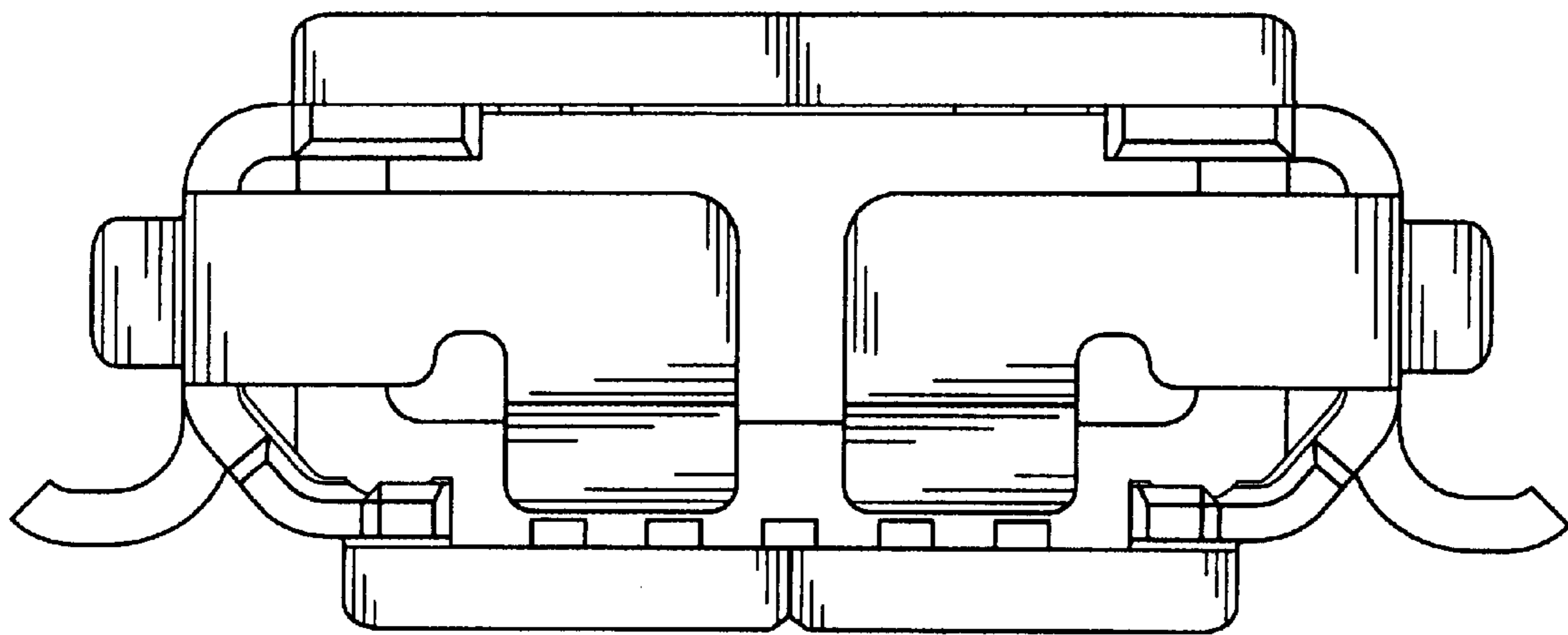

FIG. 3

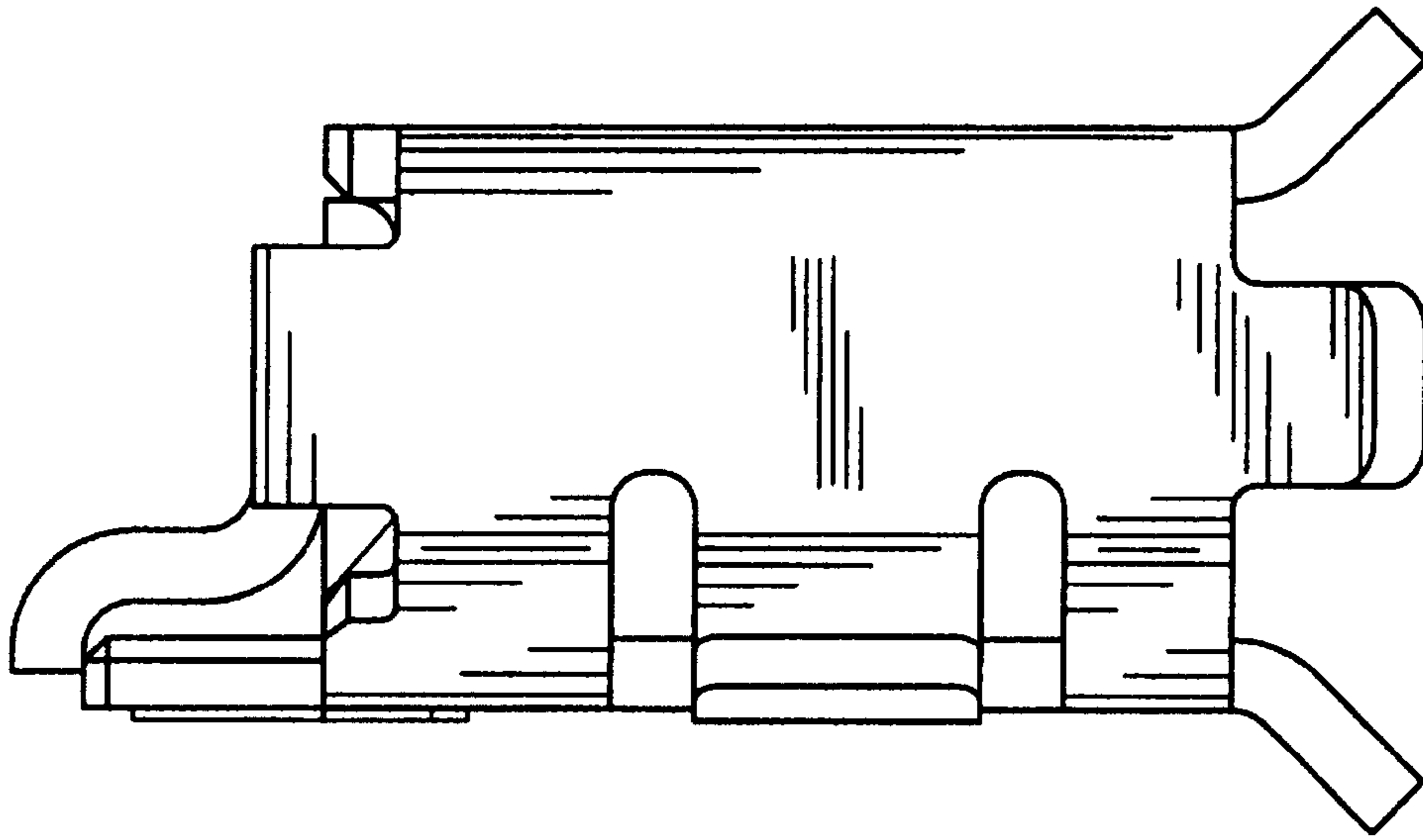

FIG. 4

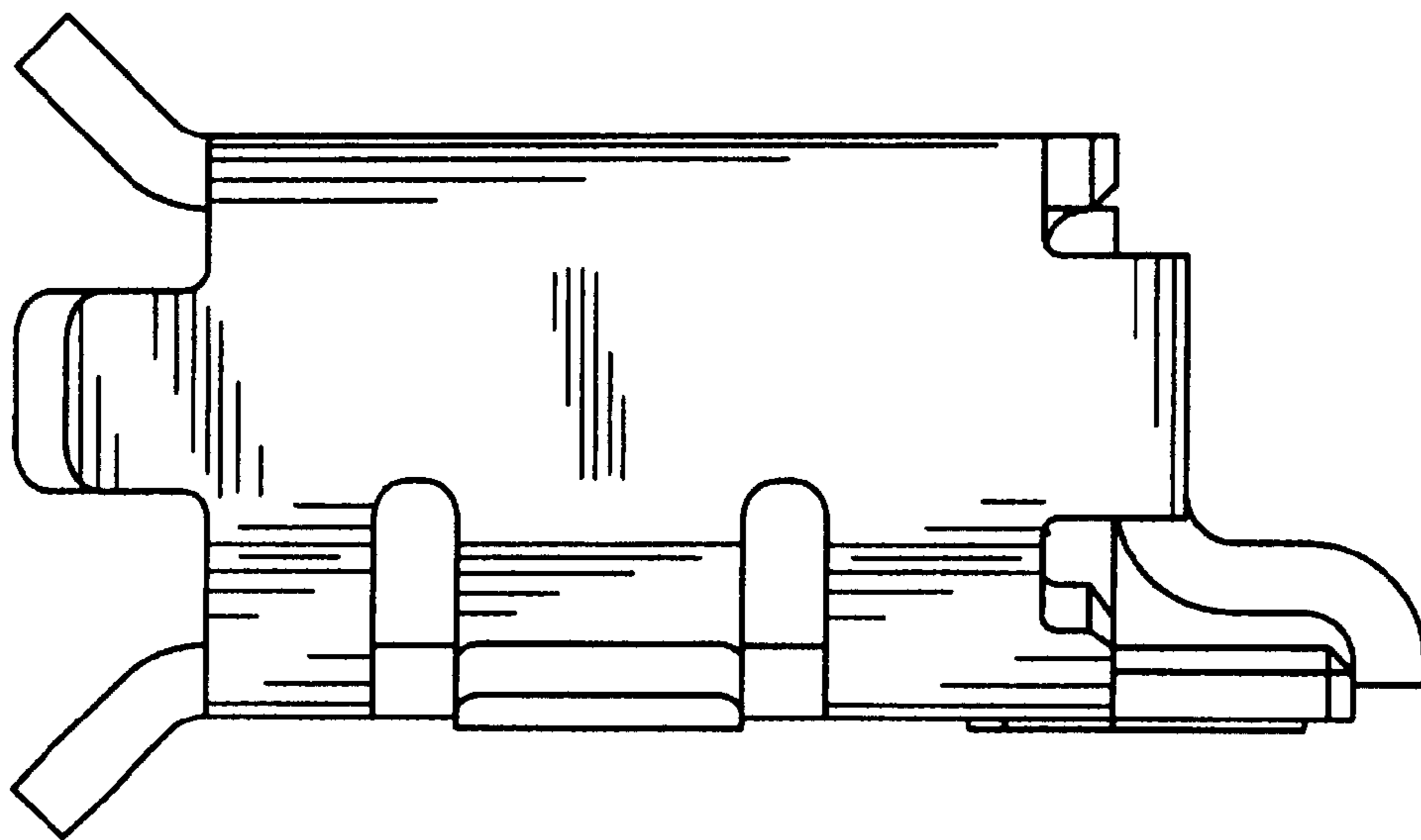

FIG. 5

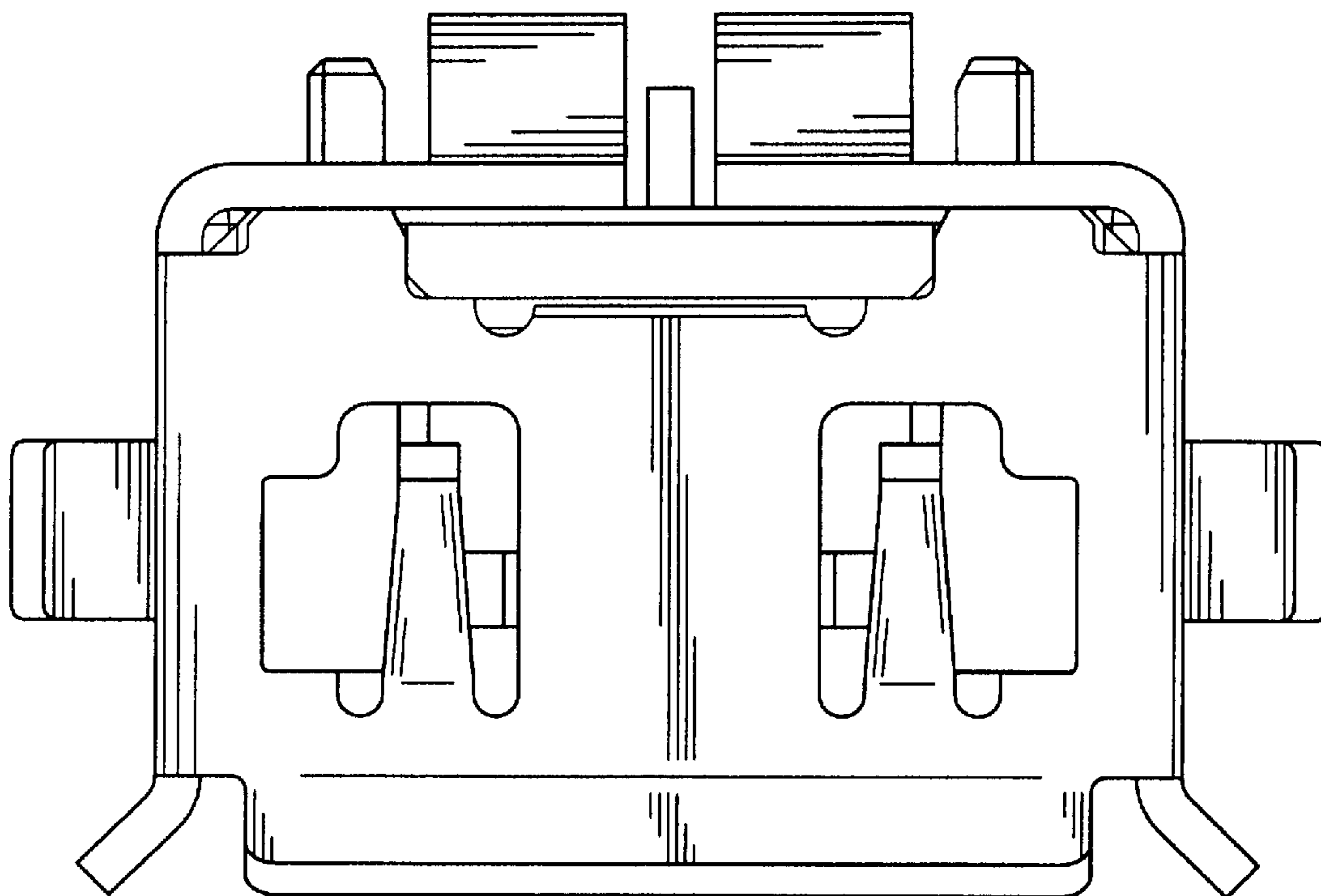

FIG. 6

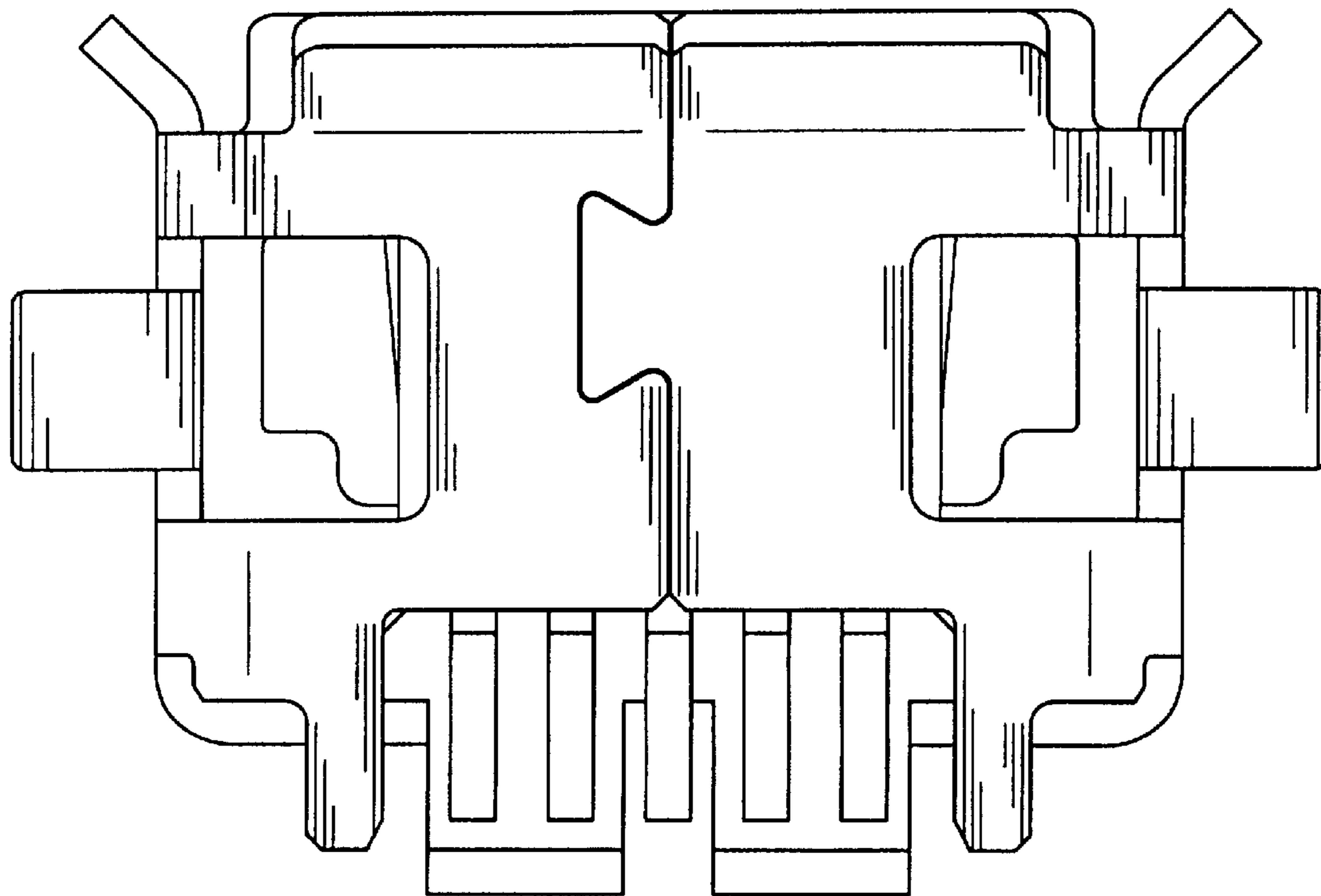

FIG. 7