

US00D540477S

(12) **United States Design Patent**  
**Price**

(10) **Patent No.:** **US D540,477 S**

(45) **Date of Patent:** **\*\* Apr. 10, 2007**

(54) **STACKABLE WALL BLOCK**

D485,371 S \* 1/2004 Burgess et al. .... D25/113  
7,059,808 B2 \* 6/2006 Risi ..... 405/284  
7,096,635 B2 8/2006 Price

(75) Inventor: **Brian A Price**, Rochester, MN (US)

(73) Assignee: **Rockwood Retaining Walls, Inc.**,  
Rochester, MN (US)

(\*\*) Term: **14 Years**

(21) Appl. No.: **29/260,132**

(22) Filed: **May 19, 2006**

(51) **LOC (8) Cl.** ..... **23-01**

(52) **U.S. Cl.** ..... **D25/113**

(58) **Field of Classification Search** ..... D25/112-118;  
D21/484-490, 499-502; 405/15-16, 33,  
405/35, 284-286; 404/29-42; 52/503, 504,  
52/575, 596-599, 603-605, 608, 612

See application file for complete search history.

(56) **References Cited**

**U.S. PATENT DOCUMENTS**

1,260,024	A	*	3/1918	Parton	.....	52/302.3
1,795,451	A	*	3/1931	Sharpe	.....	52/314
1,816,916	A	*	8/1931	Sentrop	.....	52/351
5,622,456	A	*	4/1997	Risi et al.	.....	405/284
5,647,185	A	*	7/1997	Forlini	.....	52/604
D403,437	S	*	12/1998	Risi et al.	.....	D25/113
D405,193	S	*	2/1999	Scales	.....	D25/113
D466,229	S	*	11/2002	Risi et al.	.....	D25/113
D479,342	S	*	9/2003	Dawson	.....	D25/113
6,651,401	B2		11/2003	Price et al.		

**OTHER PUBLICATIONS**

“Classic” product literature, Rockwood Retaining Walls, 12 pgs., 1997.

\* cited by examiner

*Primary Examiner*—Louis S. Zarfaz

*Assistant Examiner*—Gregory Andoll

(74) *Attorney, Agent, or Firm*—Patterson, Thunte, Skaar & Christensen, P.A.

(57) **CLAIM**

I claim the ornamental design for a stackable wall block, as shown.

**DESCRIPTION**

FIG. 1 is a perspective view of a stackable wall block showing my new design.

FIG. 2 is a front view thereof.

FIG. 3 is a rear view thereof.

FIG. 4 is a bottom view thereof.

FIG. 5 is a top view thereof; and,

FIG. 6 is a side view thereof.

The broken lines appearing in the figures are not intended to form part of the claimed design and are provided for illustrative purposes only.

**1 Claim, 2 Drawing Sheets**

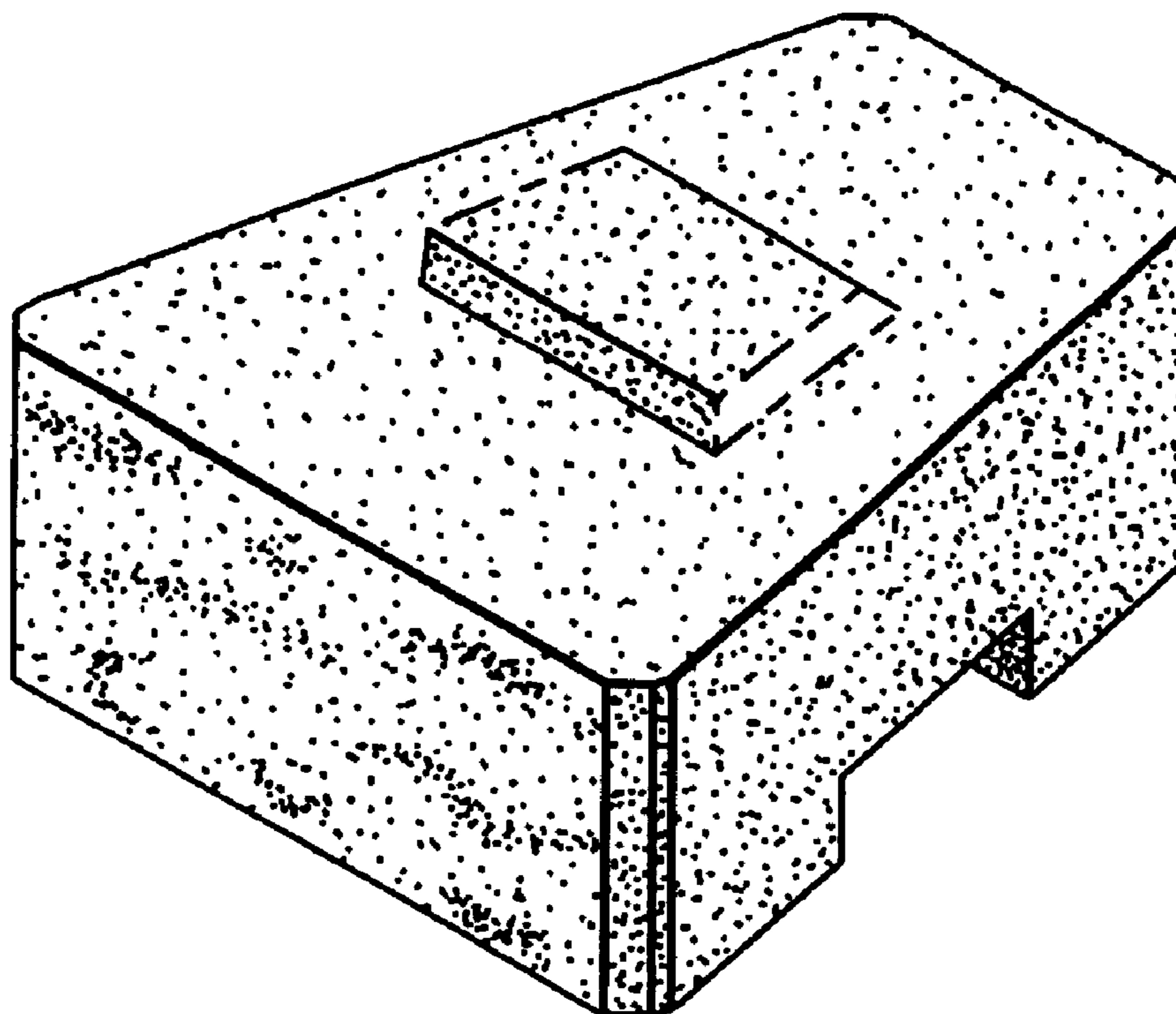

**Fig. 1**

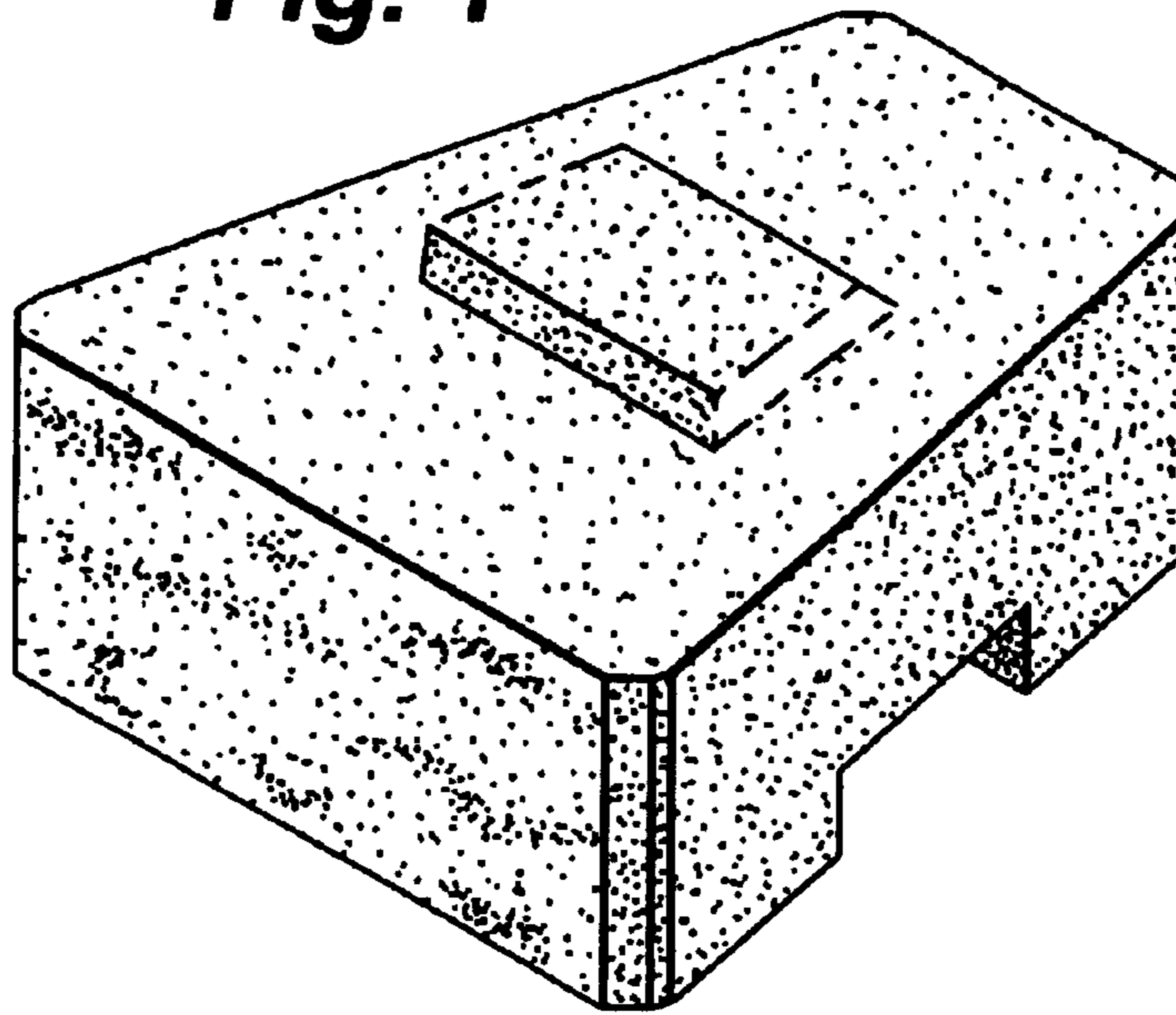

**Fig. 2**

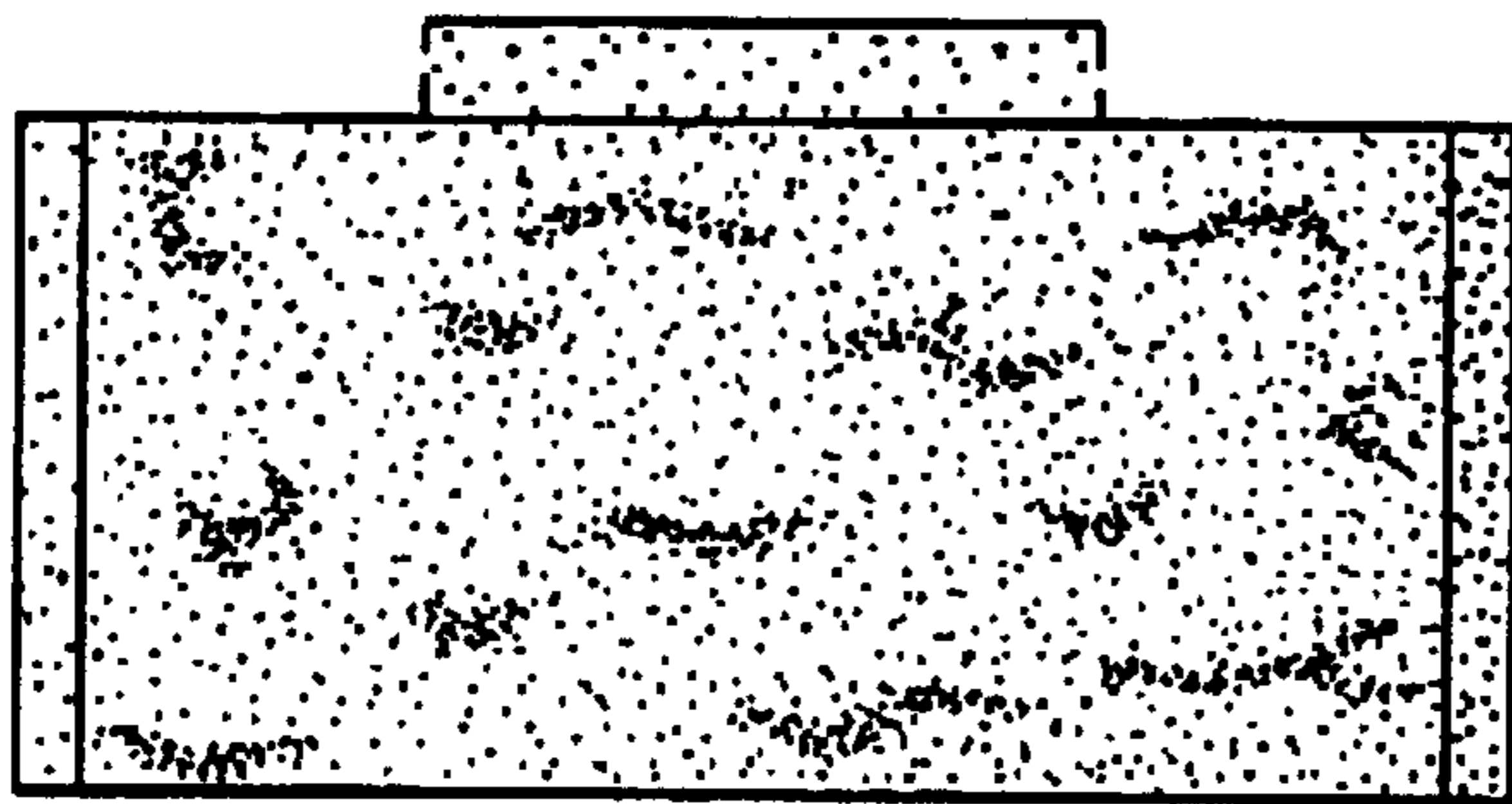

**Fig. 3**

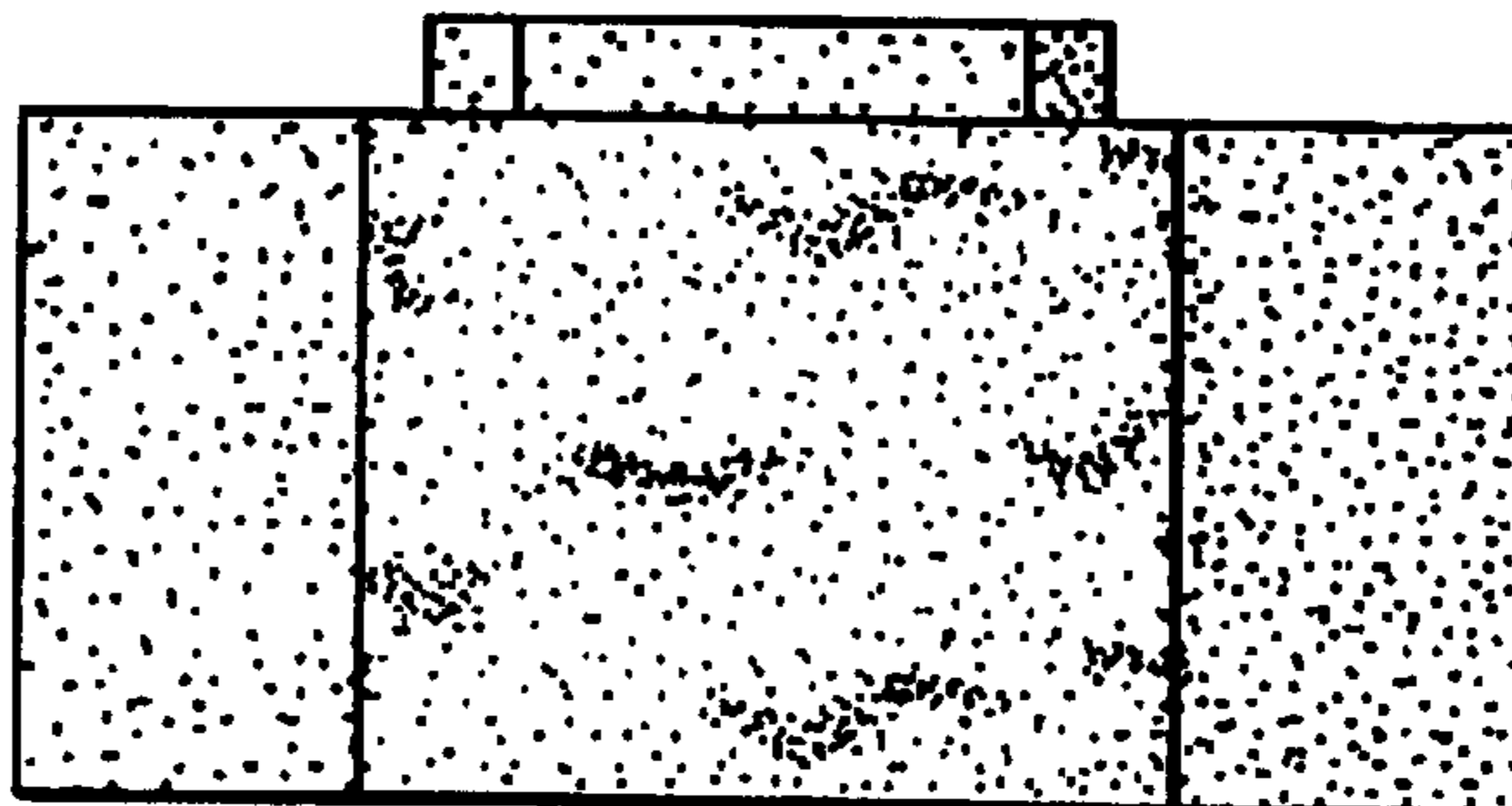

**Fig. 4**

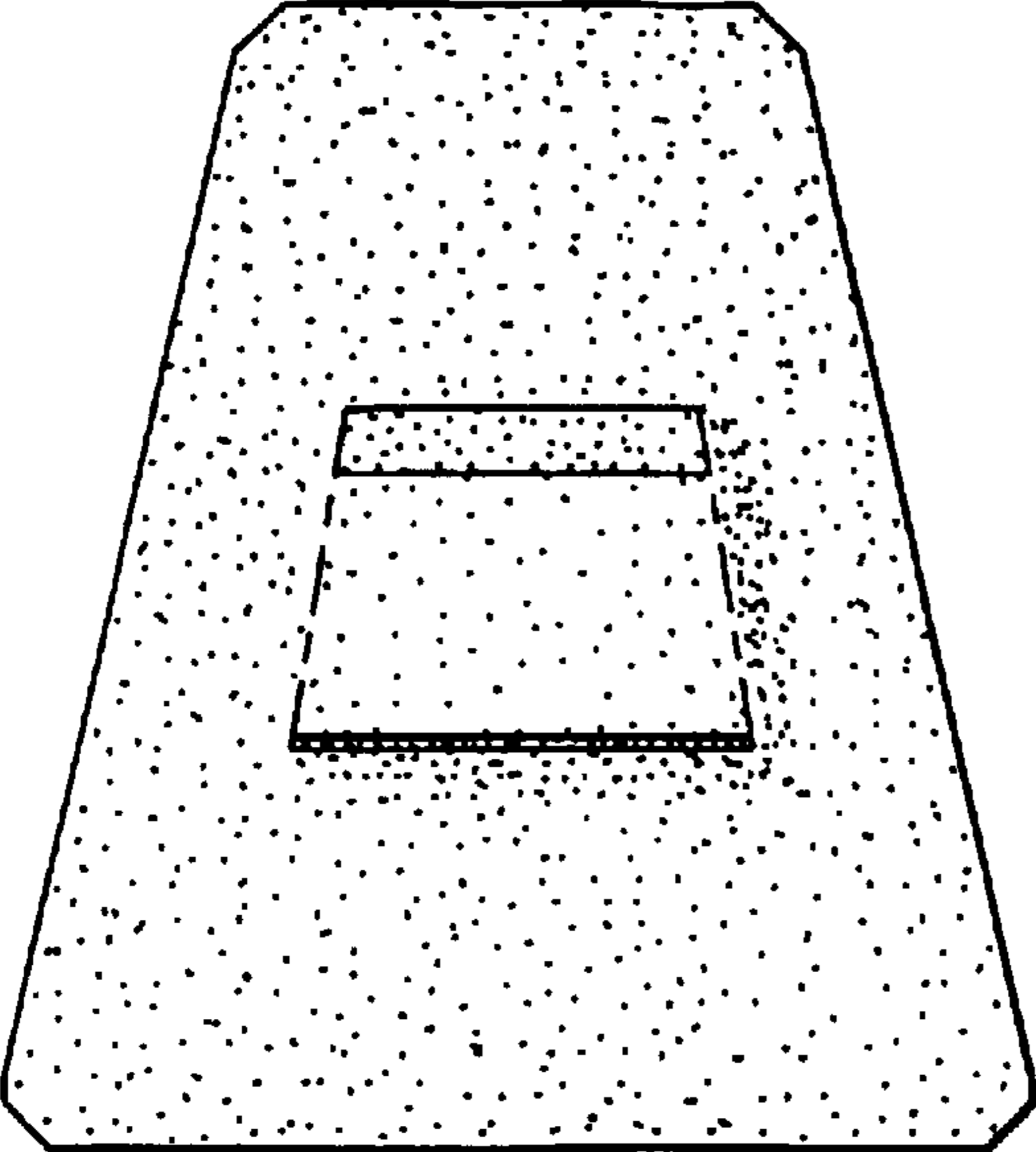

**Fig. 5**

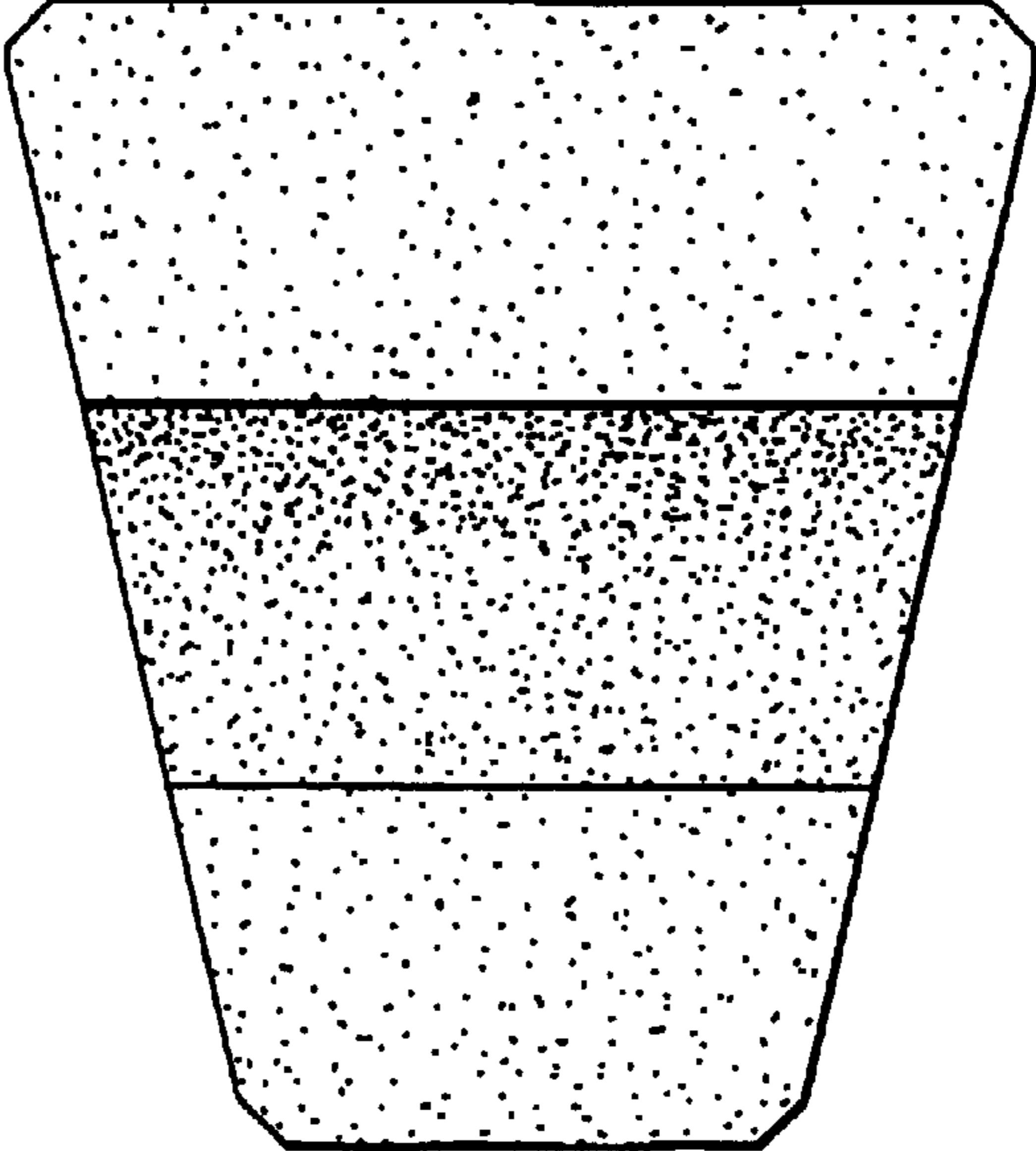

**Fig. 6**

