

US00D540220S

(12) **United States Design Patent**
Walters

(10) **Patent No.:** **US D540,220 S**

(45) **Date of Patent:** **** Apr. 10, 2007**

(54) **MOTORCYCLE**

(76) **Inventor:** **Tom Walters**, 7631 High Jackson Rd.,
Charlestown, IN (US) 47111

(**) **Term:** **14 Years**

(21) **Appl. No.:** **29/253,536**

(22) **Filed:** **Feb. 8, 2006**

(51) **LOC (8) Cl.** **12-11**

(52) **U.S. Cl.** **D12/110**

(58) **Field of Classification Search** D12/85,
D12/107, 112, 110; 180/210-212, 215, 217,
180/219; 280/202-204

See application file for complete search history.

(56) **References Cited**

U.S. PATENT DOCUMENTS

D246,776 S * 12/1977 Moore D12/110

D517,959 S * 3/2006 Pickering D12/110

* cited by examiner

Primary Examiner—Alan P. Douglas

Assistant Examiner—Linda Brooks

(74) *Attorney, Agent, or Firm*—Camoriano and Associate;
Theresa Fritz Camoriano; John M. Lenczyk

(57) **CLAIM**

The ornamental design for a motorcycle, as shown and described.

DESCRIPTION

FIG. 1 is a front perspective view showing my new design;
FIG. 2 is a top view thereof;
FIG. 3 is a right side view thereof;
FIG. 4 is a left side view thereof;
FIG. 5 is a front view thereof; and,
FIG. 6 is a rear view thereof.

The wheels shown in broken lines in FIGS. 1-6 are for illustrative purposes only and form no part of the claimed design.

1 Claim, 3 Drawing Sheets

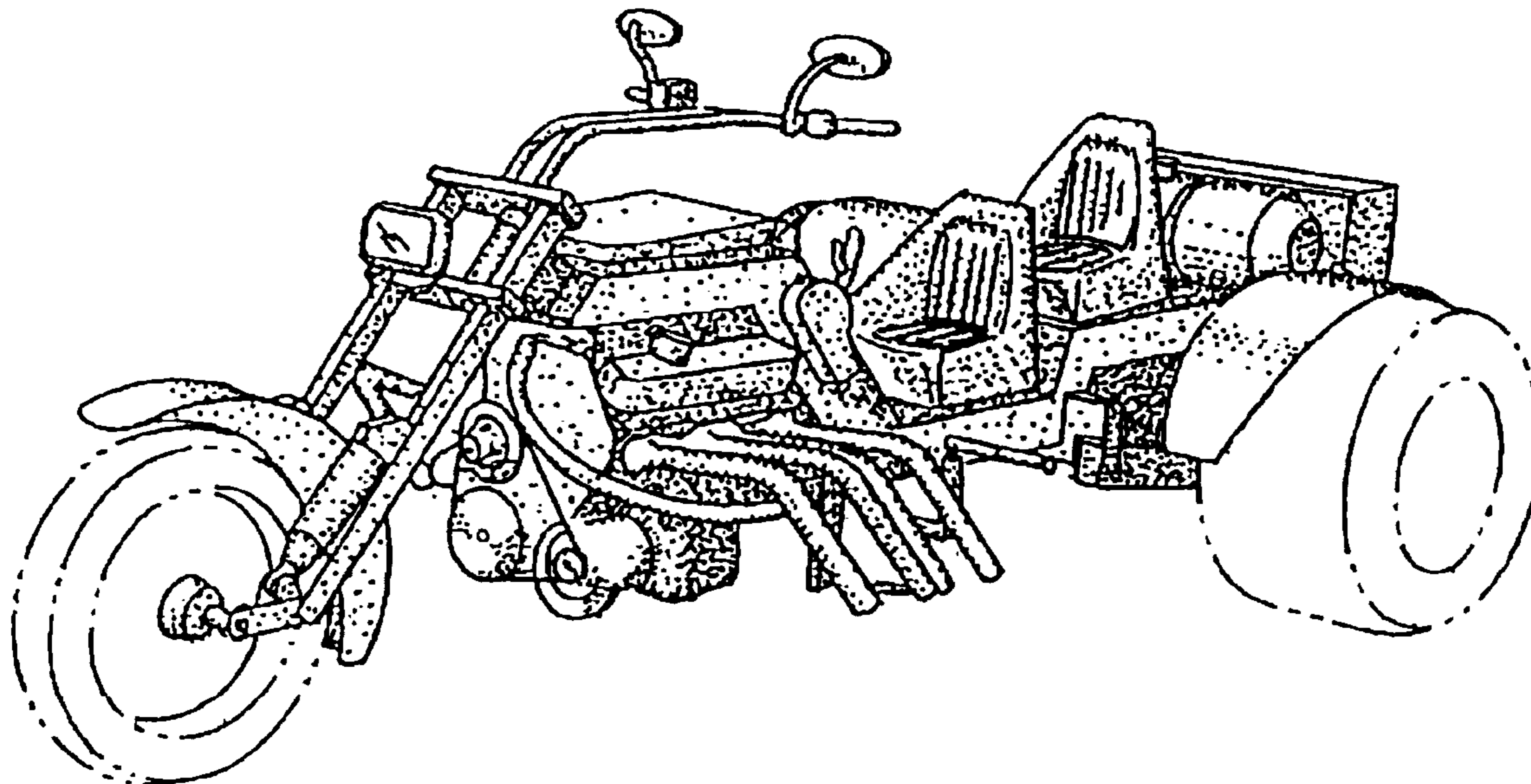

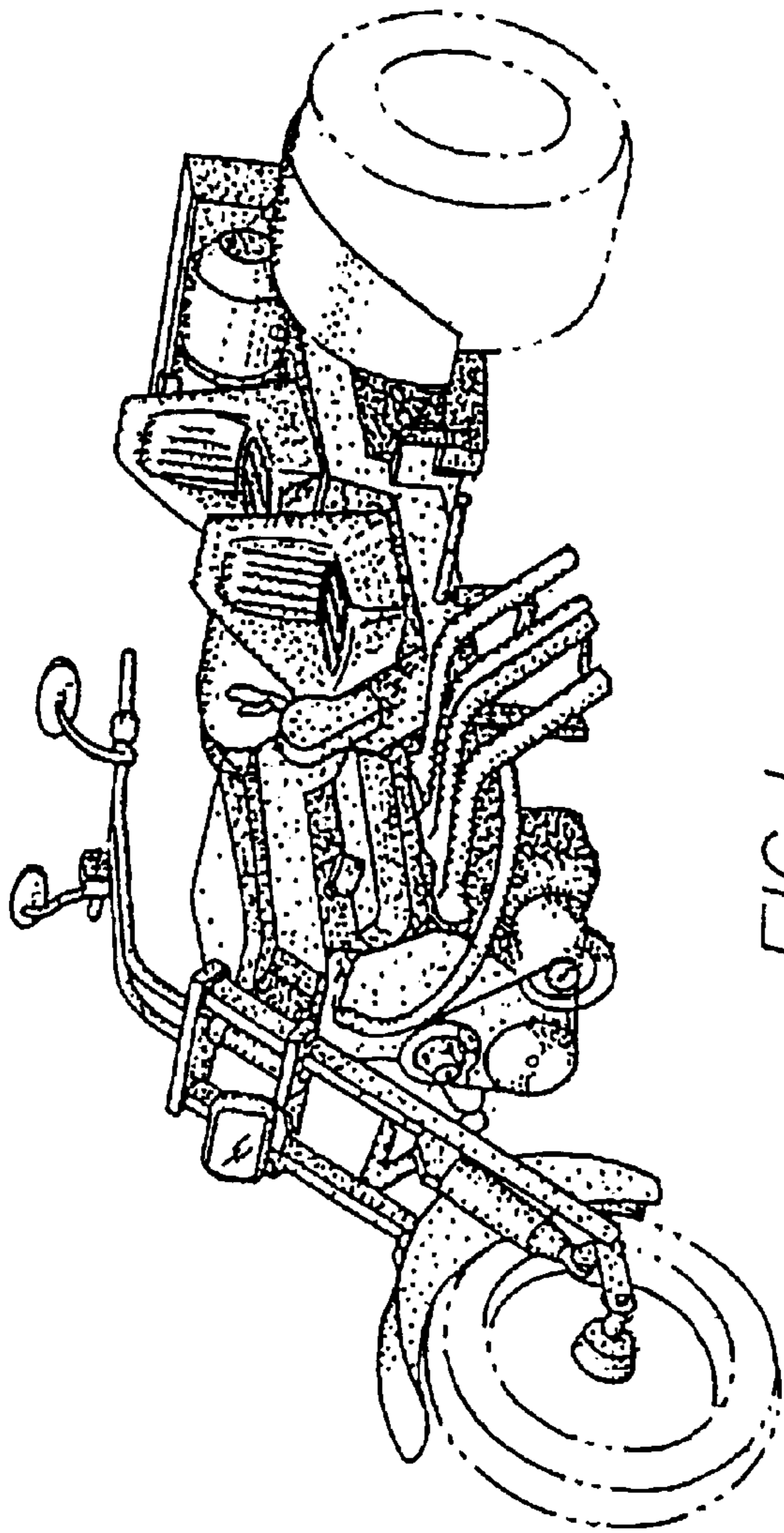

FIG. 1

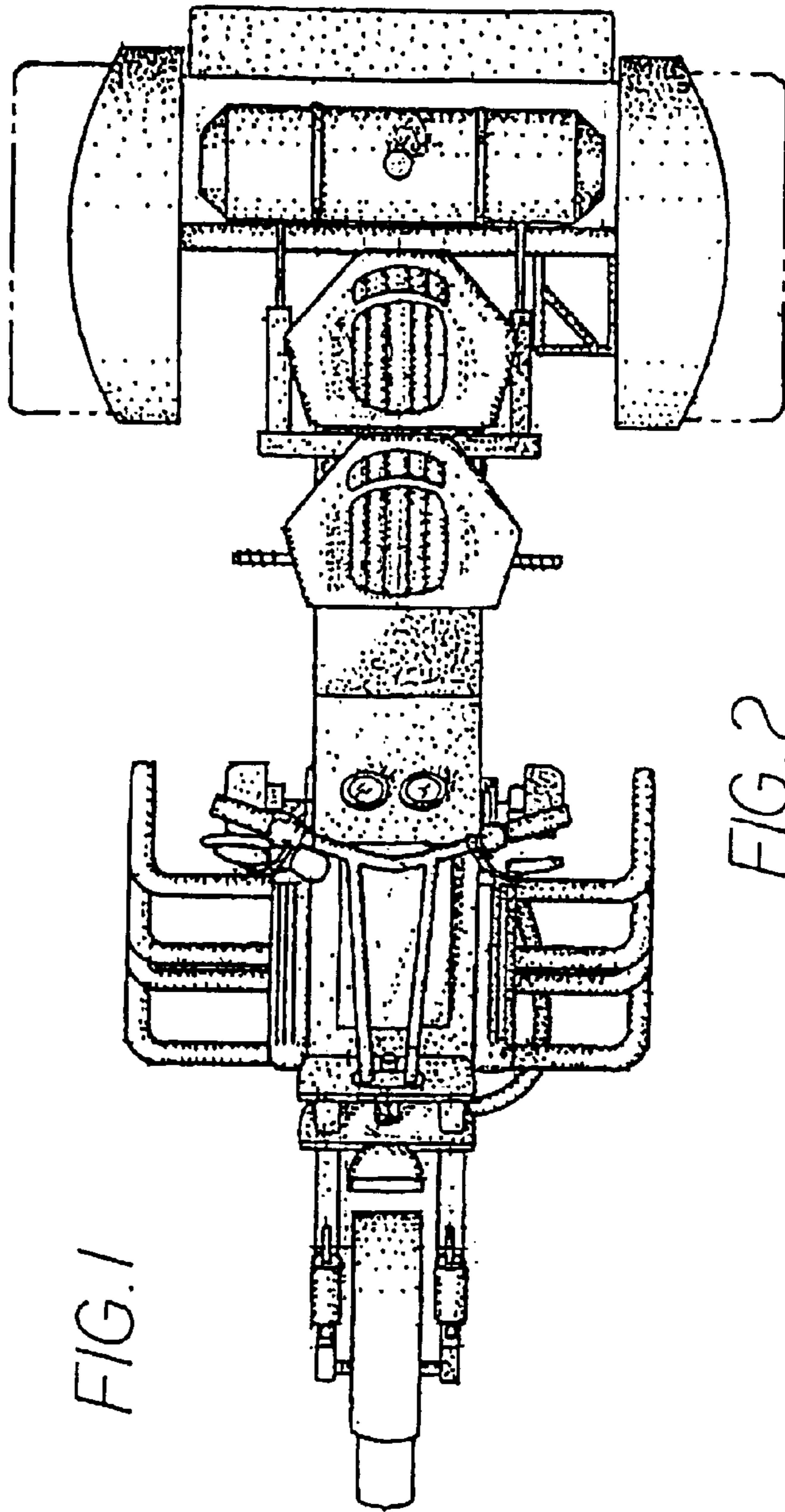

FIG. 2

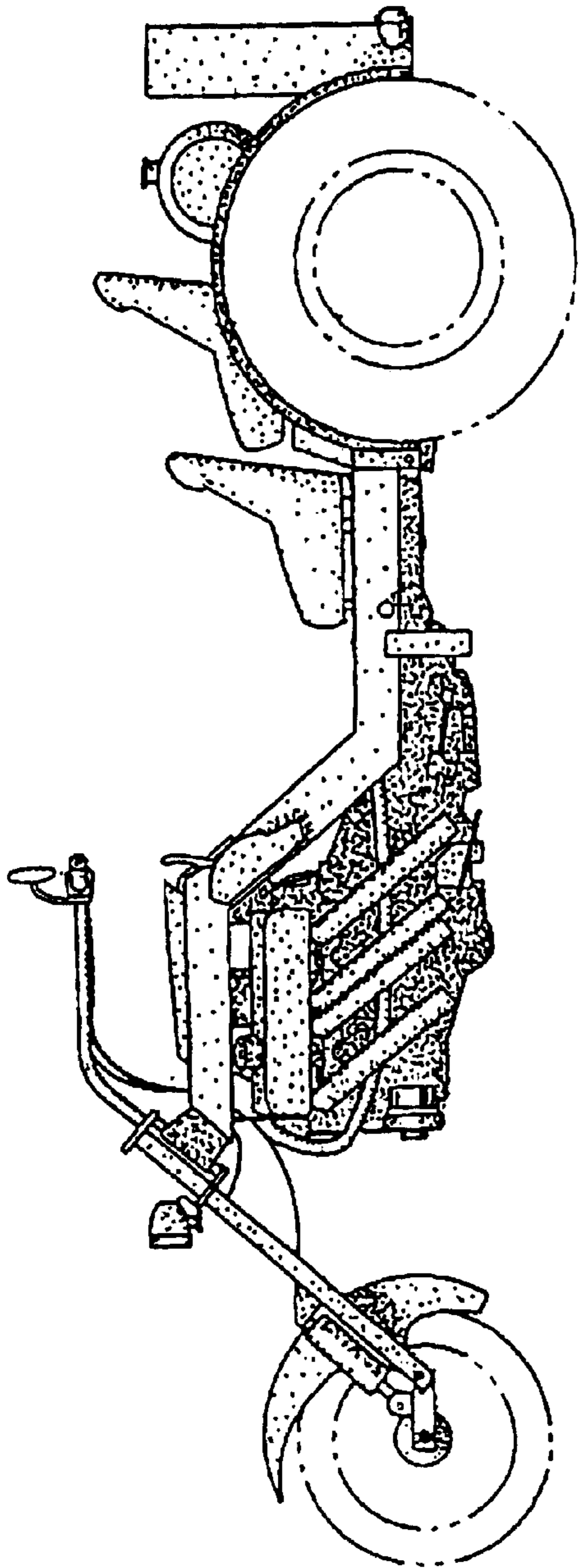

FIG. 3

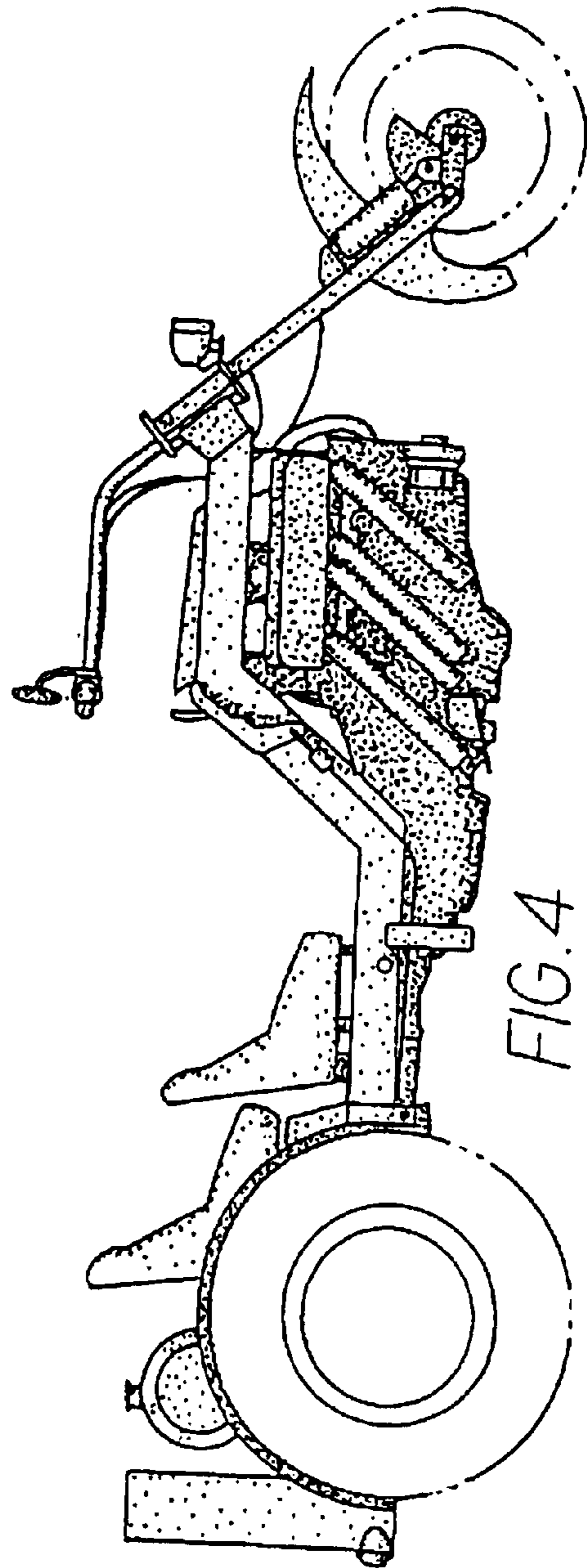

FIG. 4

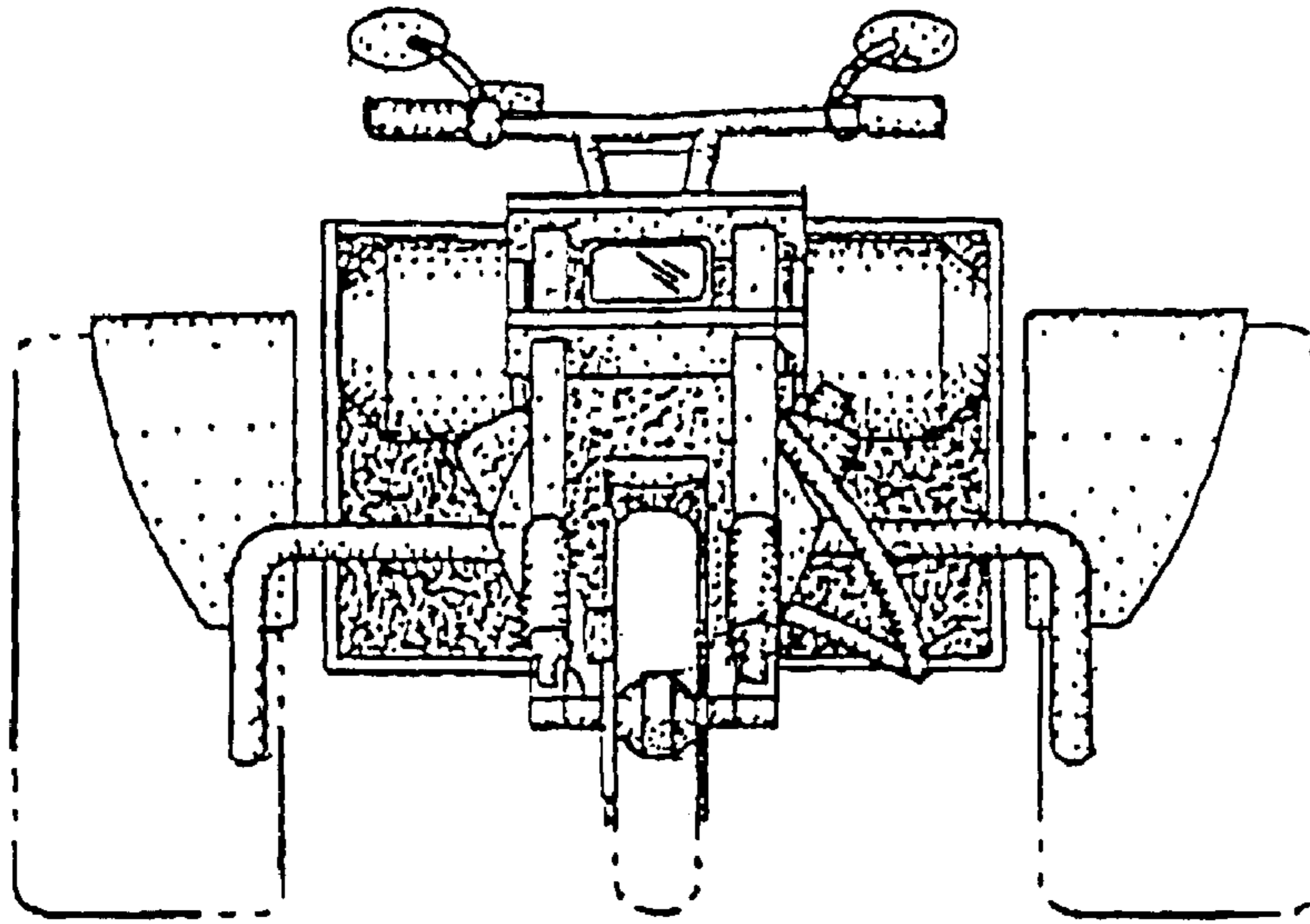

FIG. 5

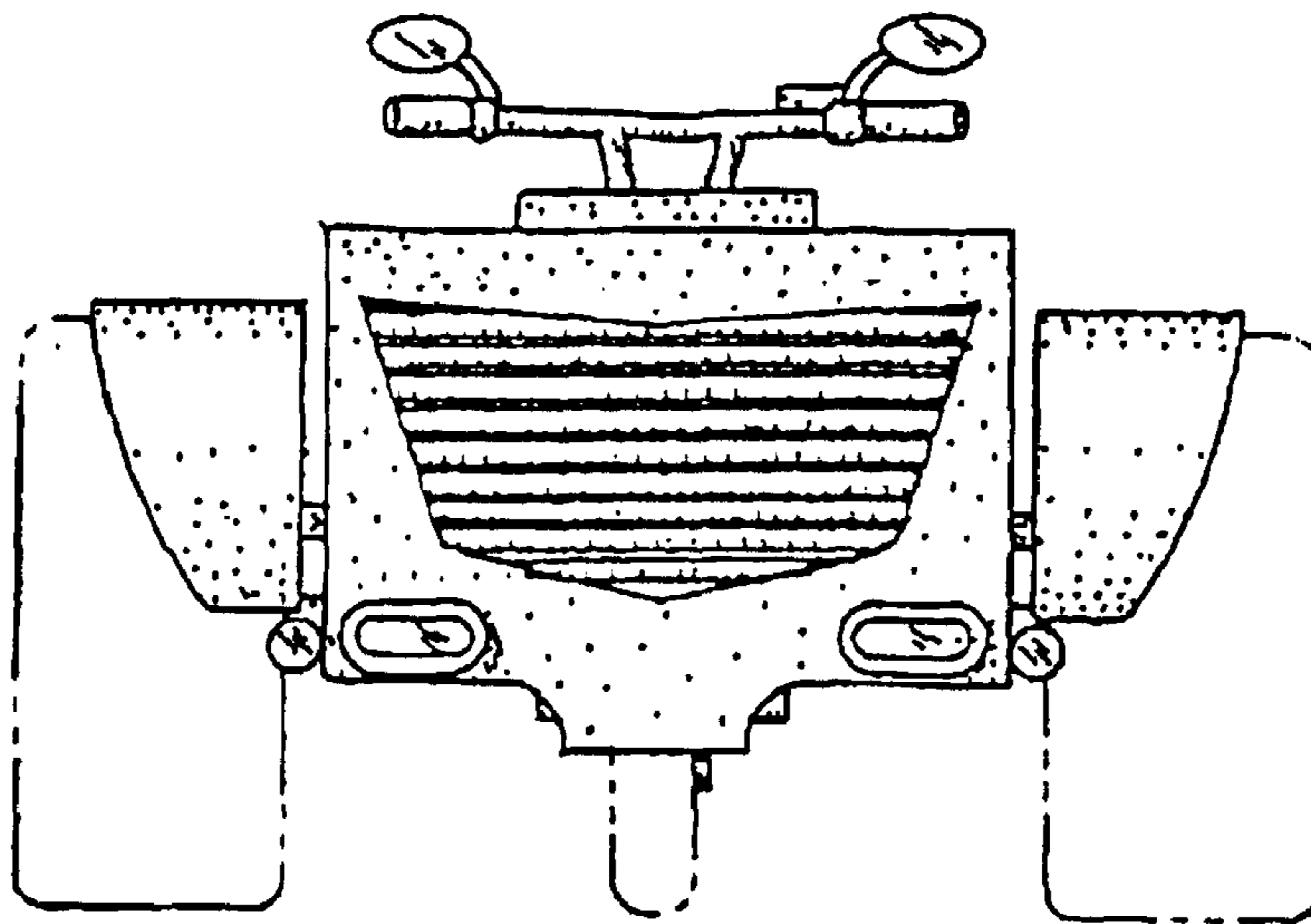

FIG. 6