



US00D540213S

(12) **United States Design Patent**
Markefka

(10) **Patent No.:** **US D540,213 S**

(45) **Date of Patent:** **** Apr. 10, 2007**

(54) **SURFACE CONFIGURATION OF A VEHICLE, TOY, AND/OR OTHER REPLICAS**

JP 1192413 12/2003

* cited by examiner

(75) Inventor: **Marc Michael Markefka**, Munich (DE)

Primary Examiner—Melody N. Brown

(74) *Attorney, Agent, or Firm*—Crowell & Moring LLP

(73) Assignee: **Bayerische Motoren Werke Aktiengesellschaft**, Munich (DE)

(57) **CLAIM**

(**) Term: **14 Years**

The ornamental design for a surface configuration of a vehicle, toy, and/or other replicas, as shown and described.

(21) Appl. No.: **29/255,177**

(22) Filed: **Mar. 7, 2006**

(30) **Foreign Application Priority Data**

Sep. 8, 2005 (DE) 40504712

(51) **LOC (8) Cl.** **12-08**

(52) **U.S. Cl.** **D12/91**

(58) **Field of Classification Search** D12/90–92, D12/86; D21/424, 433, 548; 296/181.1, 181.5
See application file for complete search history.

DESCRIPTION

This application is related to the following co-pending applications, of the inventor, filed on even date herewith: application Ser. No. 29/255,176, entitled “Surface Configuration of a Vehicle, Toy, and/or Other Replicas”; application Ser. No. 29/255,185, entitled “Surface Configuration of a Rear Fender for a Vehicle”; application Ser. No. 29/255,187, entitled “Surface Configuration of a Front Bumper for a Vehicle”; application Ser. No. 29/255,180, entitled “Surface Configuration of a Rear Bumper for a Vehicle”; and application Ser. No. 29/255,172, entitled “Surface Configuration of a Side Mirror for a Vehicle”.

FIG. 1 is a left, front perspective view of a surface configuration of a vehicle, toy, and/or other replicas according to my novel design, the right, front perspective view being mirror symmetrical;

FIG. 2 is a left, rear perspective view thereof, the right, rear perspective view being mirror symmetrical;

FIG. 3 is a left side view thereof;

FIG. 4 is a right side view thereof;

FIG. 5 is a front view thereof;

FIG. 6 is a rear view thereof; and,

FIG. 7 is a top view thereof.

The broken lines are for illustrative purposes only and form no part of the claimed design.

(56) **References Cited**

U.S. PATENT DOCUMENTS

D396,432 S	*	7/1998	Syring	D12/91
D478,533 S	*	8/2003	Nicholas et al.	D12/91
D483,298 S		12/2003	van Hooydonk		
D490,019 S	*	5/2004	Sakae	D12/91
D504,087 S	*	4/2005	Hakamata et al.	D12/91
D513,716 S	*	1/2006	Acampora	D12/91
D514,985 S	*	2/2006	Nagashima	D12/92
D521,907 S	*	5/2006	Elmitt	D12/92

FOREIGN PATENT DOCUMENTS

EM 000252523-0001 2/2005

1 Claim, 6 Drawing Sheets

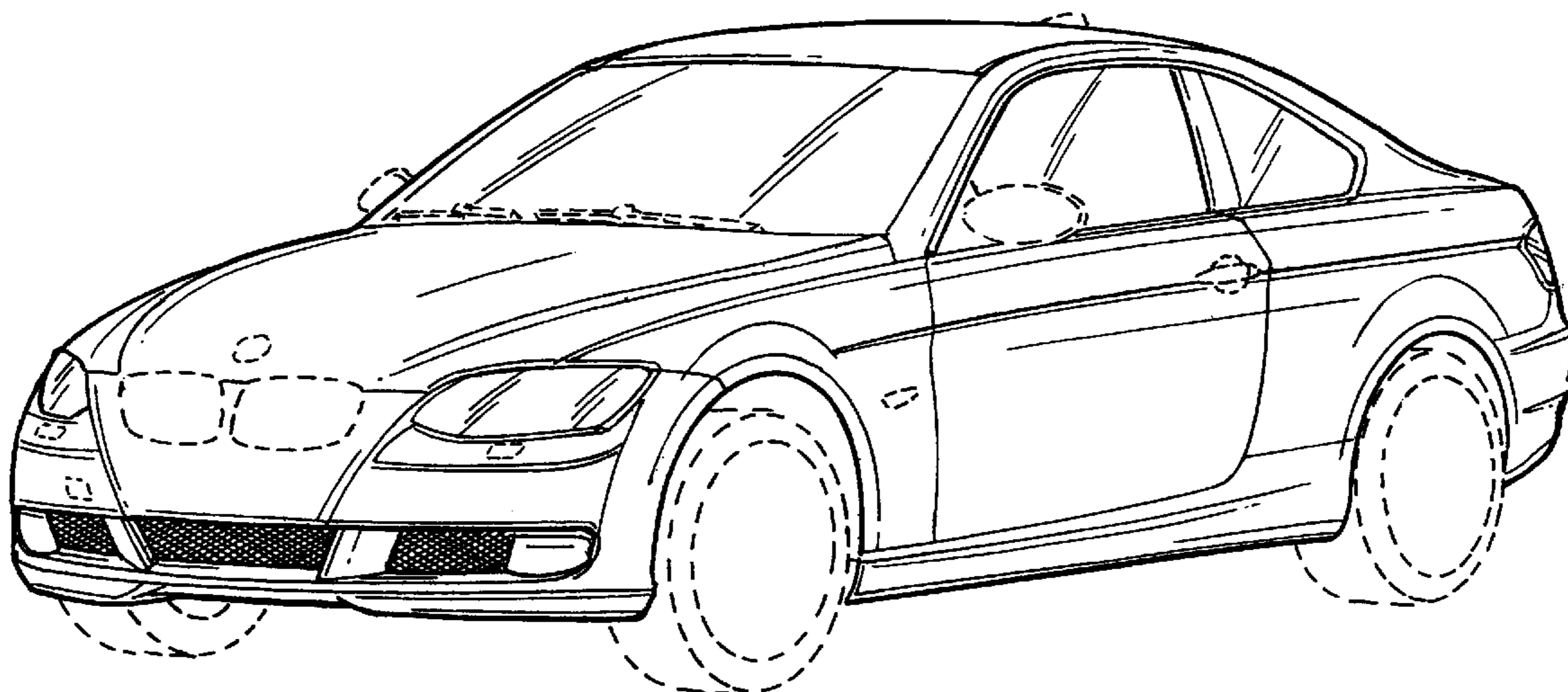

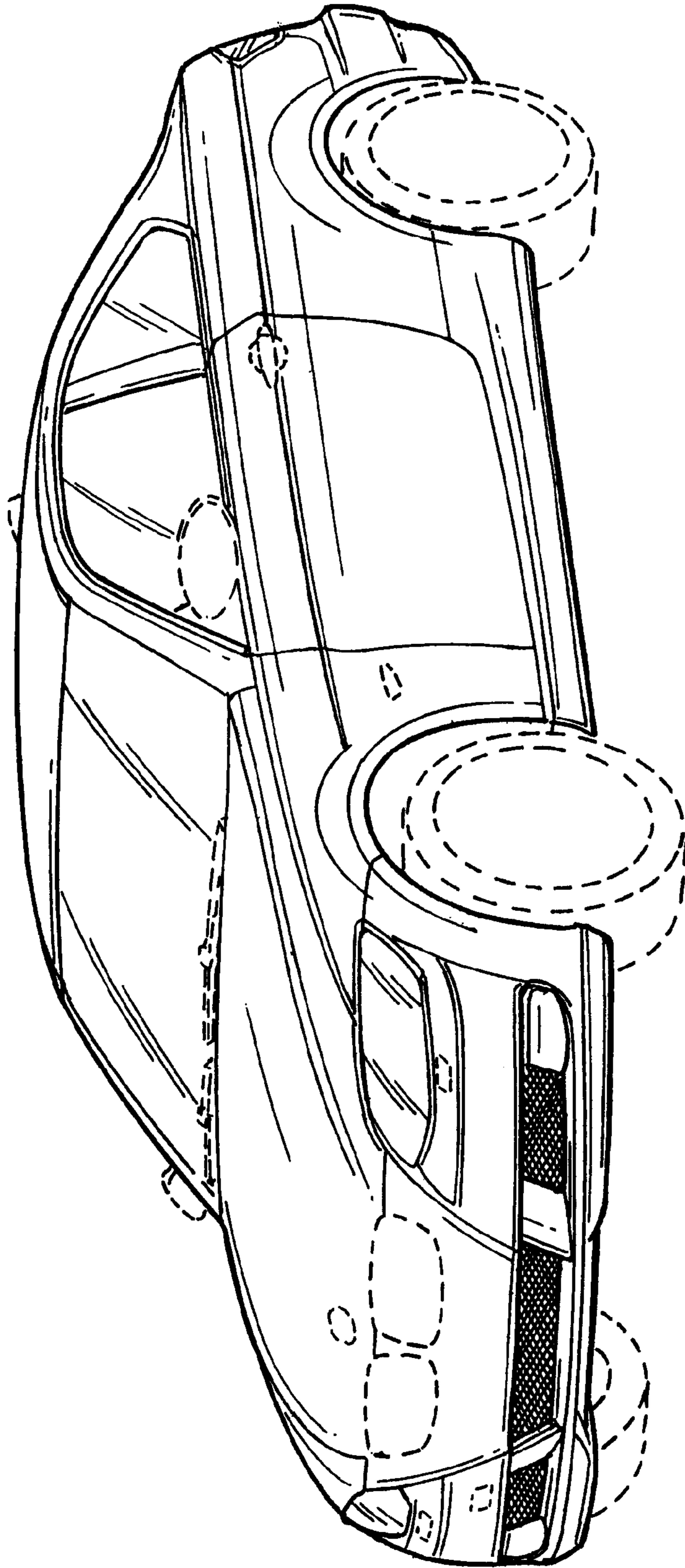

FIG. 1

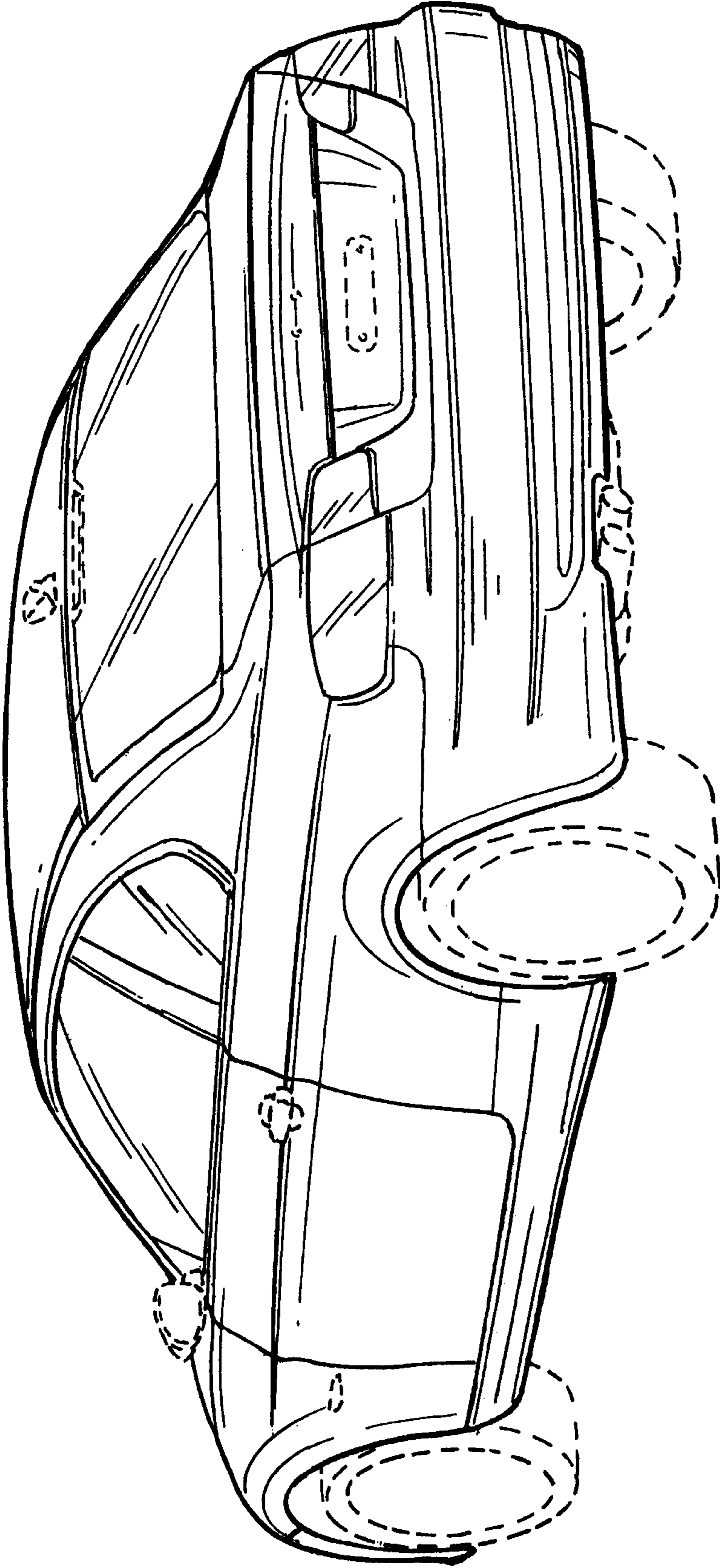

FIG. 2

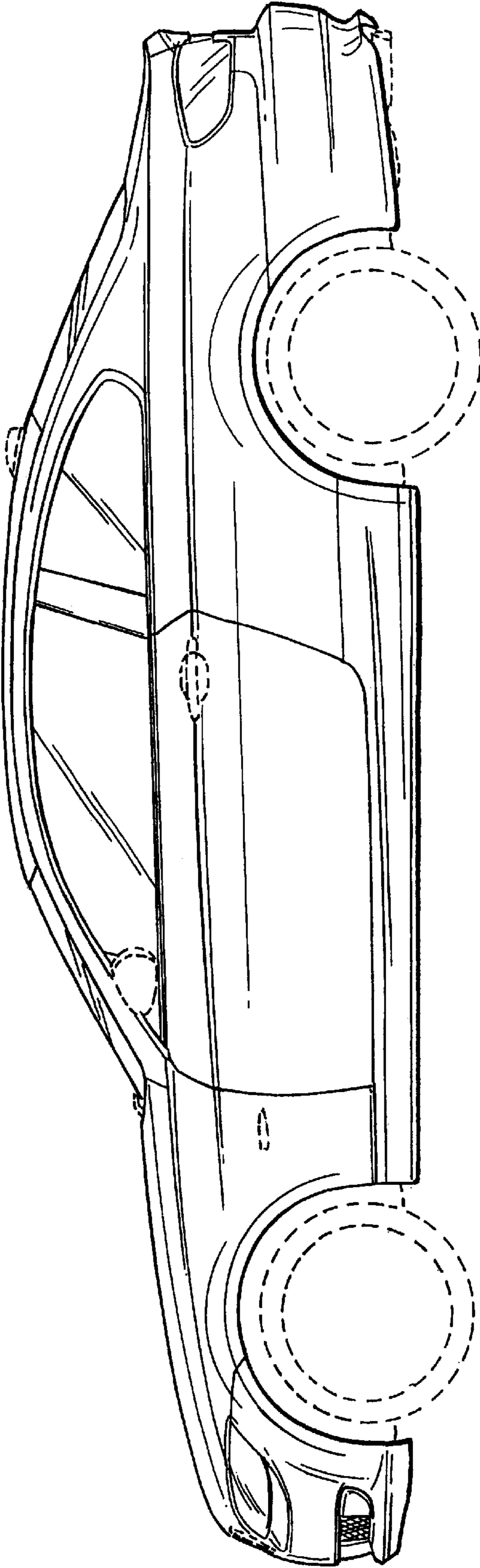

FIG. 3

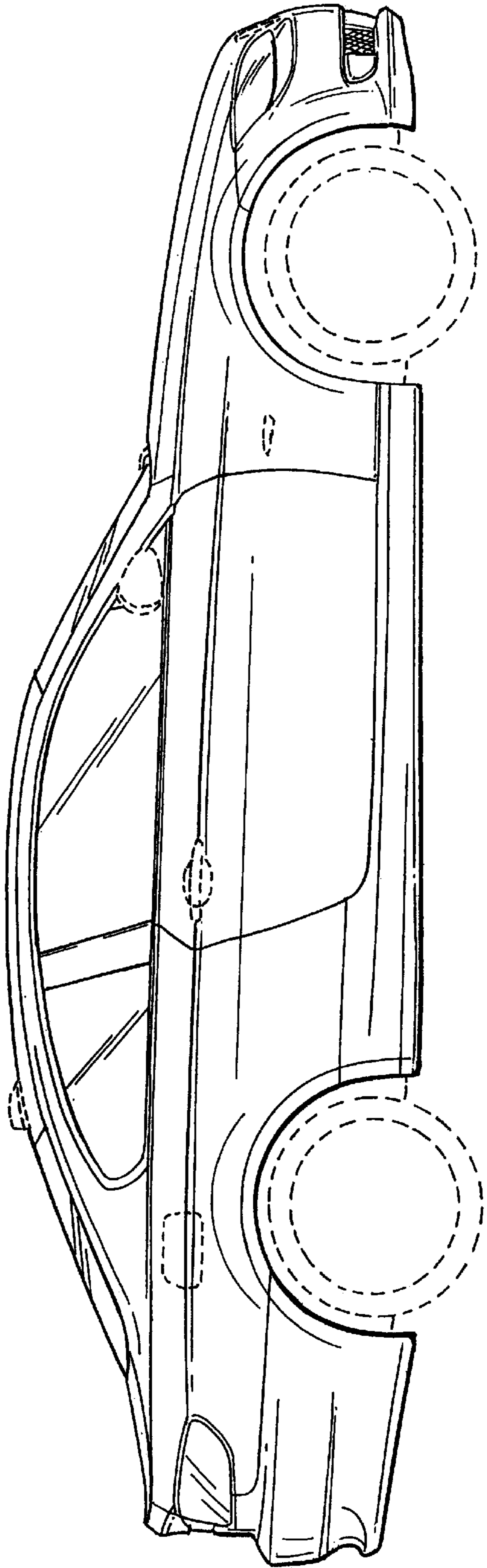

FIG. 4

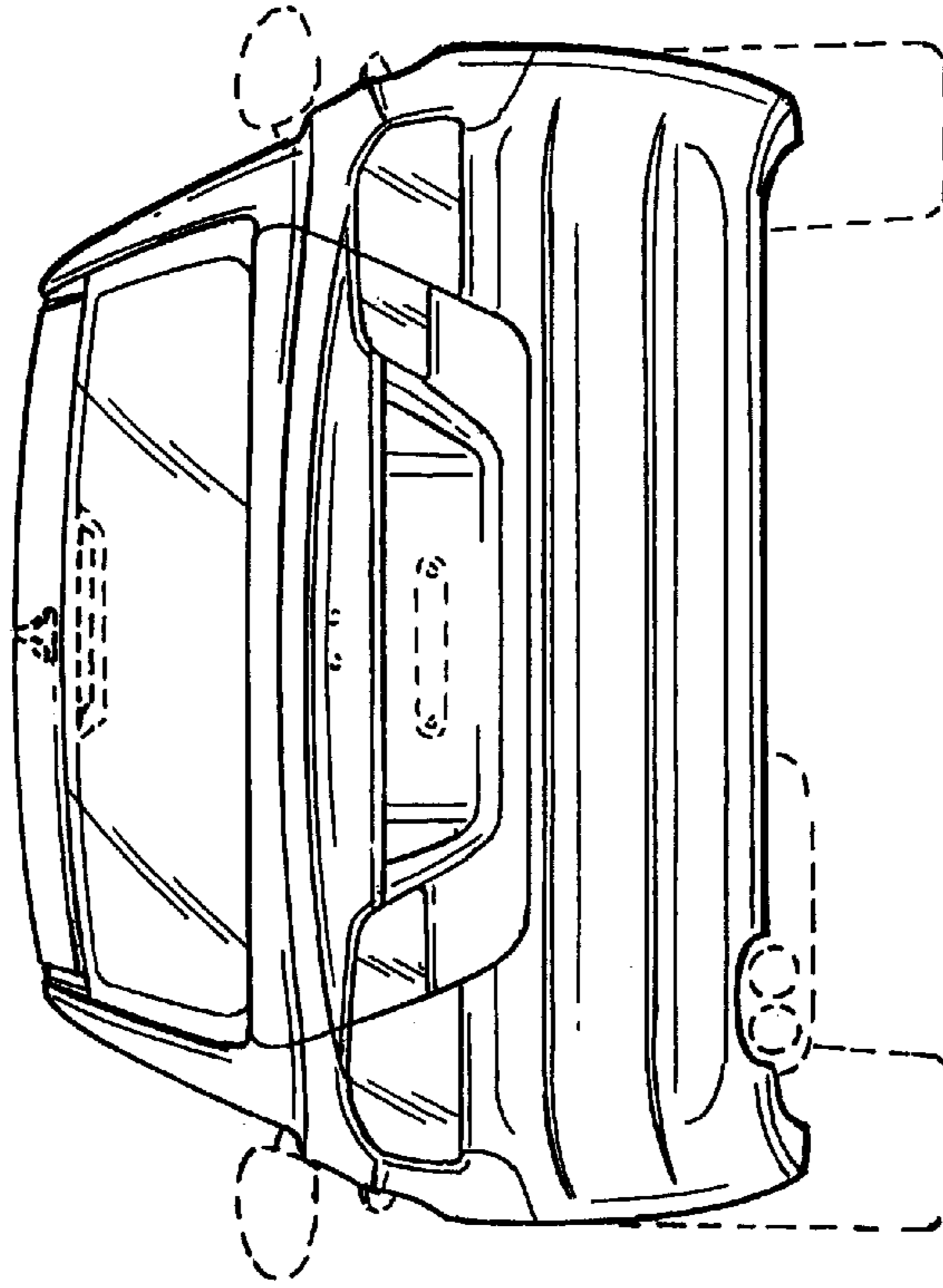

FIG. 5

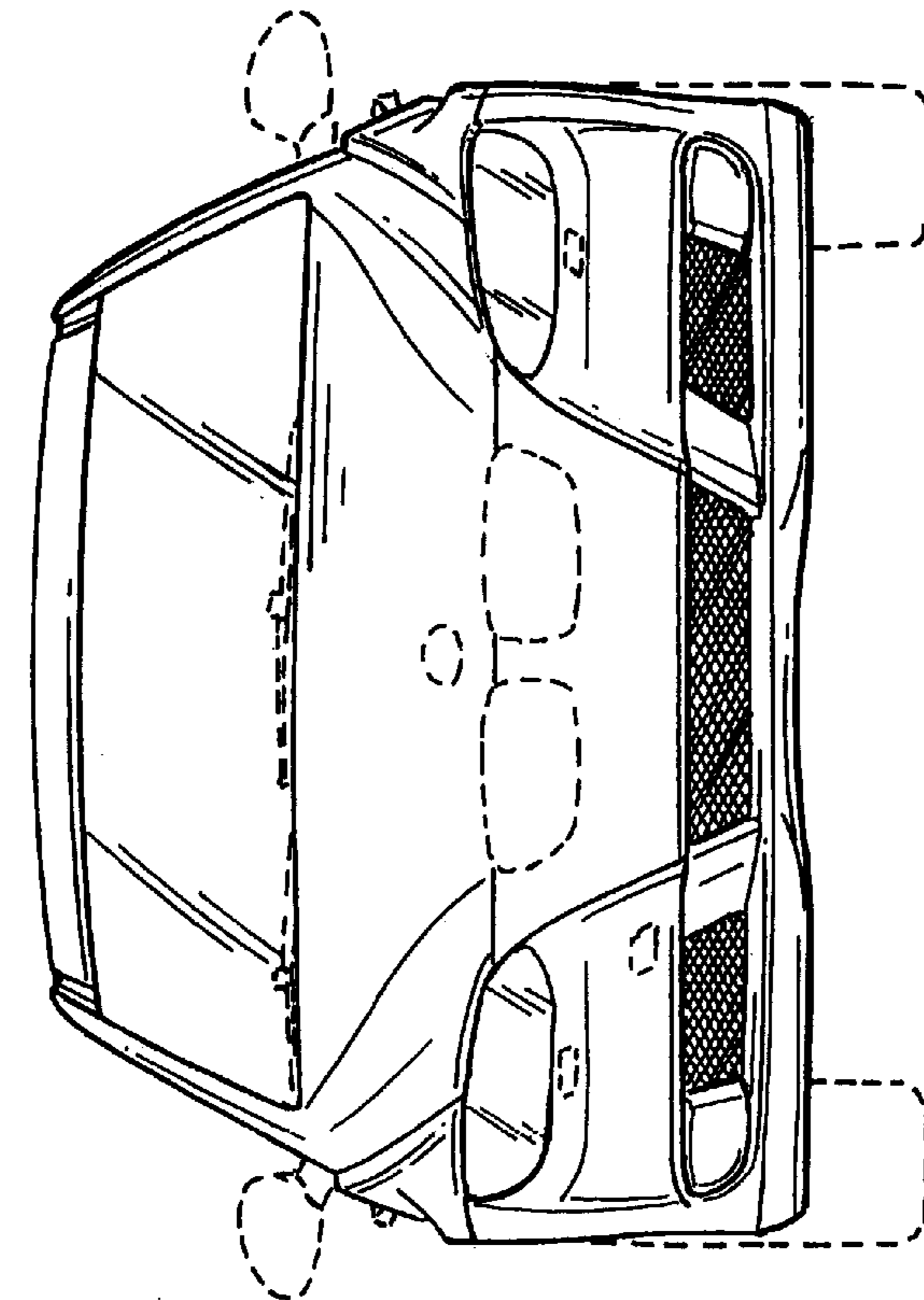

FIG. 6

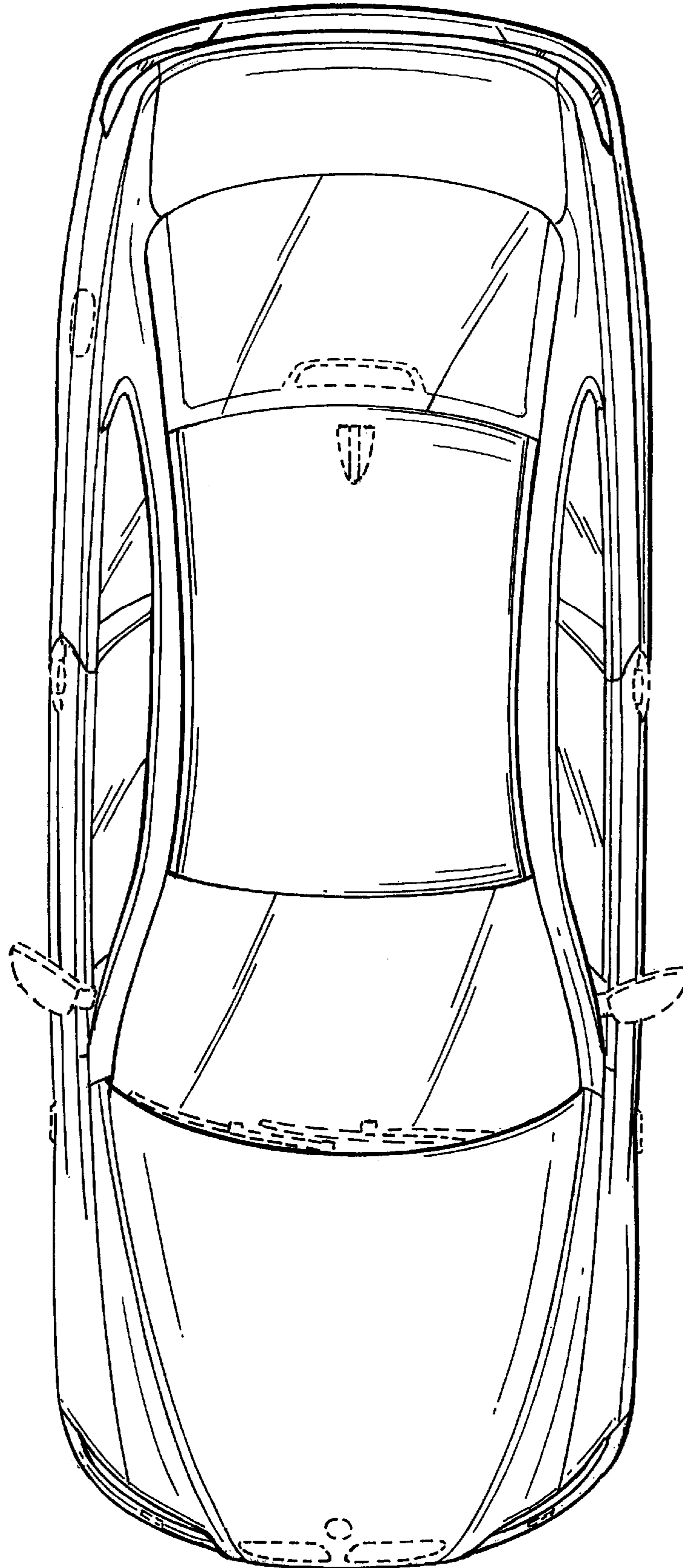

FIG. 7