

US00D539350S

(12) **United States Design Patent**  
**Vazquez Gastellu**

(10) **Patent No.: US D539,350 S**  
(45) **Date of Patent: \*\* Mar. 27, 2007**

(54) **DIDACTIC TOY FOR MATHEMATICS**

**DESCRIPTION**

(75) Inventor: **Alma Rosa Vazquez Gastellu**, Morelos (MX)

(73) Assignee: **Abastecedora Rimova S.A. de C.V.**, Obregon (MX)

(\*\*) Term: **14 Years**

(21) Appl. No.: **29/240,976**

(22) Filed: **Oct. 21, 2005**

(51) **LOC (8) Cl.** ..... **19-07**

(52) **U.S. Cl.** ..... **D19/64**

(58) **Field of Classification Search** ..... D19/52,  
D19/59-64; 40/621, 904; 434/188, 193, 209,  
434/211, 407, 430

See application file for complete search history.

(56) **References Cited**

**U.S. PATENT DOCUMENTS**

D184,396 S	*	2/1959	Jenkins	.....	D19/59
3,339,295 A	*	9/1967	Wanvig	.....	434/209
D252,758 S	*	8/1979	Prall	.....	D19/62
D388,461 S	*	12/1997	Smith et al.	.....	D19/64
5,699,631 A	*	12/1997	Tyson	.....	40/621
5,865,627 A	*	2/1999	Foresman	.....	434/193
D444,176 S	*	6/2001	Leslie	.....	D19/59
D502,964 S	*	3/2005	Cziraky	.....	D19/52

\* cited by examiner

*Primary Examiner*—Robert A. Delehanty

*Assistant Examiner*—Mark Cavanna

(74) *Attorney, Agent, or Firm*—Egbert Law Offices

(57) **CLAIM**

I claim the ornamental design for a didactic toy for mathematics, as shown and described.

FIG. 1 is a front perspective view of a didactic toy for mathematics showing my design.

FIG. 2 is an exploded perspective view thereof;

FIG. 3 is a front perspective view of the board element;

FIG. 4 is a front view thereof;

FIG. 5 is a side view with the opposite side being a mirror image thereof;

FIG. 6 is a back view thereof;

FIG. 7 is a slightly enlarged side view of the base element with the opposite side being a mirror image thereof;

FIG. 8 is a slightly enlarged end view with the opposite side being a mirror image thereof;

FIG. 9 is a slightly enlarged top view thereof;

FIG. 10 is an enlarged perspective view of a tile piece with the number “9” shown in broken lines forming no part of the claimed design;

FIG. 11 is an enlarged side view with the opposite side being a mirror image thereof;

FIG. 12 is an enlarged front view thereof;

FIG. 13 is an enlarged perspective view of a mounting tool;

FIG. 14 is an enlarged front view thereof;

FIG. 15 is an enlarged side view thereof;

FIG. 16 is an enlarged top plan view thereof;

FIG. 17 is an enlarged exploded perspective view of a spinning dial piece element;

FIG. 18 is a greatly enlarged partial broken away perspective view of the board, showing the application of the tile piece with the mounting tool. The like tile piece and the number “9” and the Letter “A” are shown in broken lines forming no part of the claimed design;

FIG. 19 is another enlarged perspective view of a didactic toy for mathematics with all numerals and markings shown in broken lines forming no part of the claimed design; and,

FIG. 20 is another enlarged perspective view of a didactic toy for mathematics with all letters and markings shown in broken lines forming no part of the claimed design.

**1 Claim, 7 Drawing Sheets**

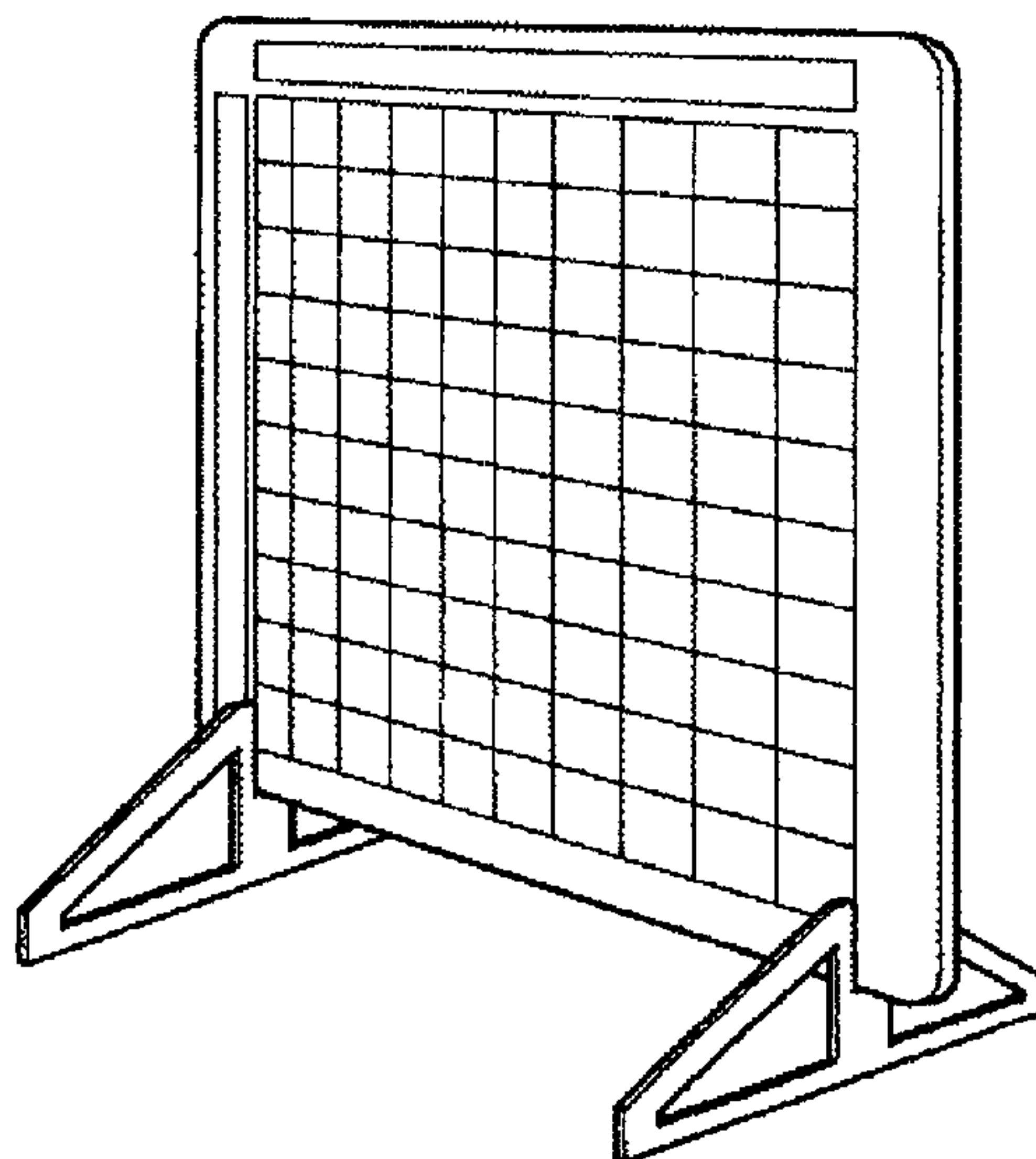

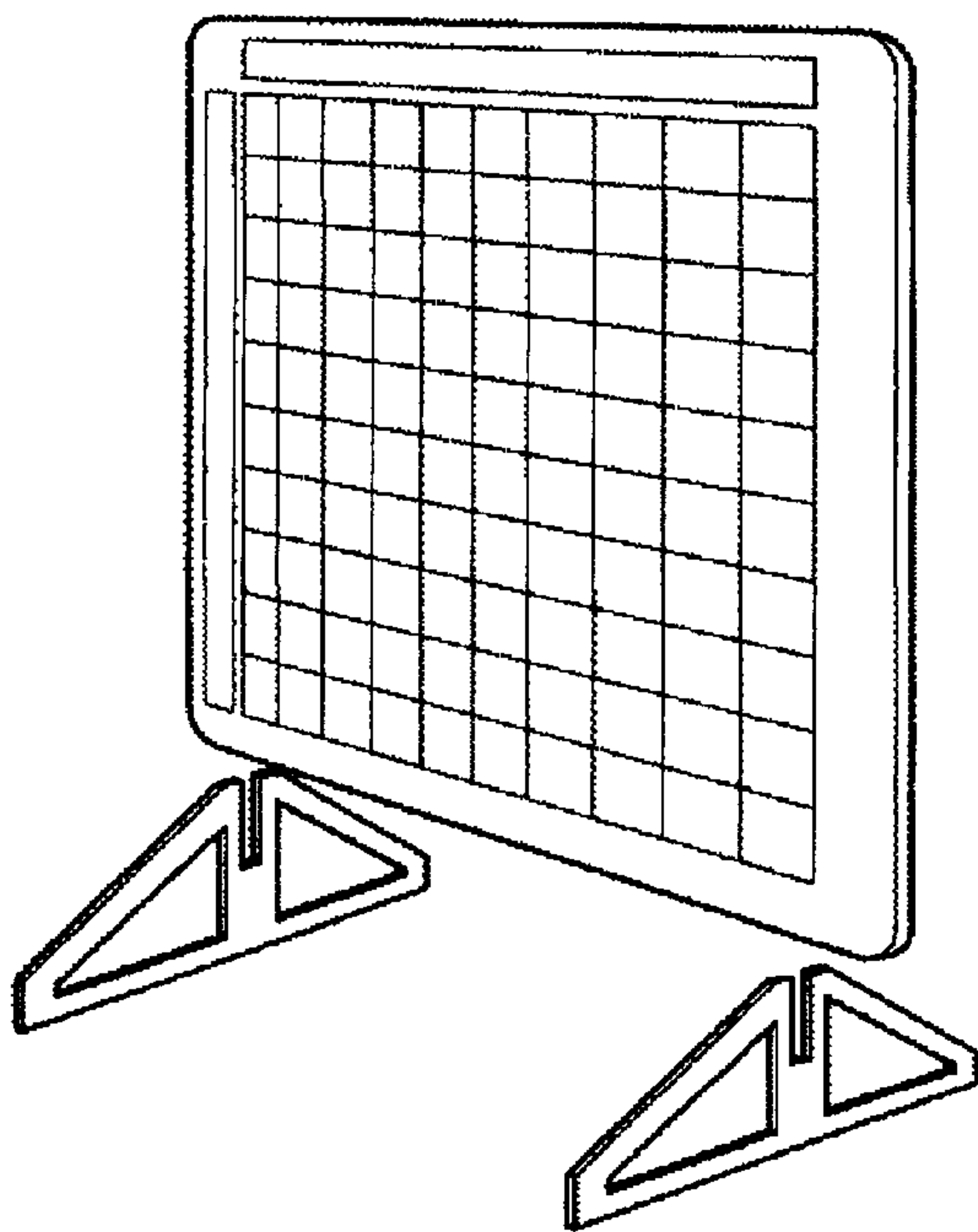

Fig. 2

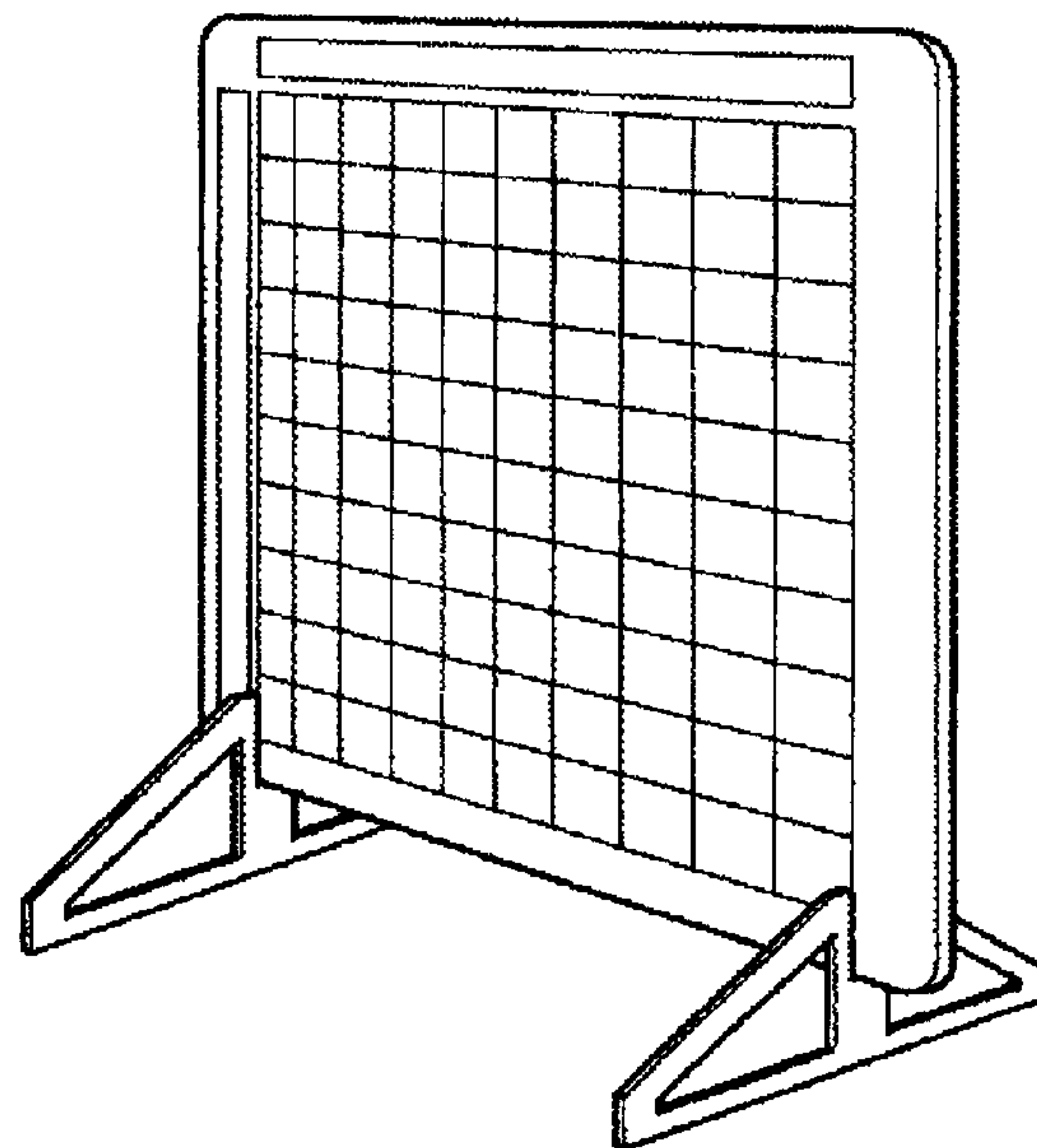

Fig. 1

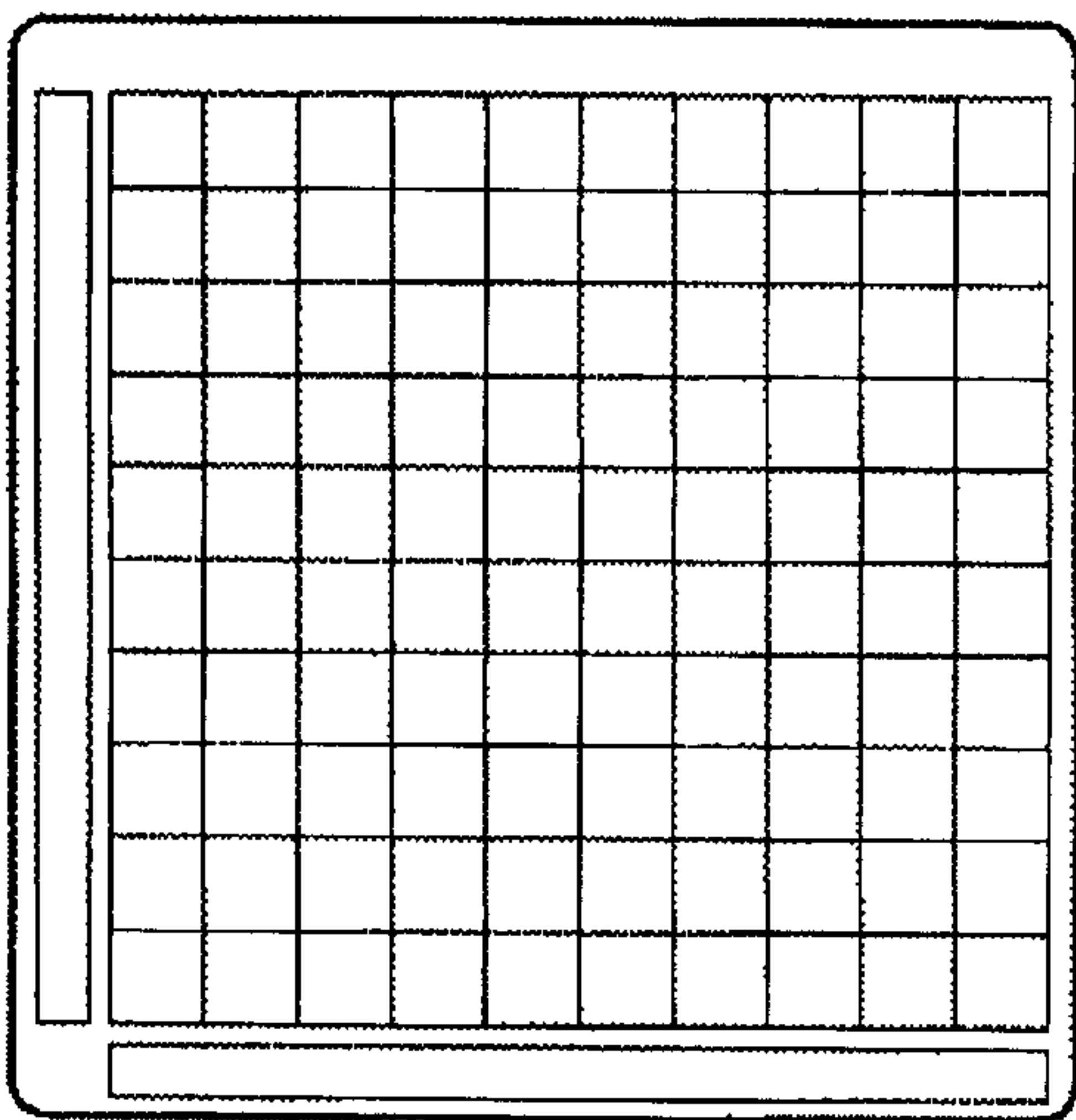

Fig. 4

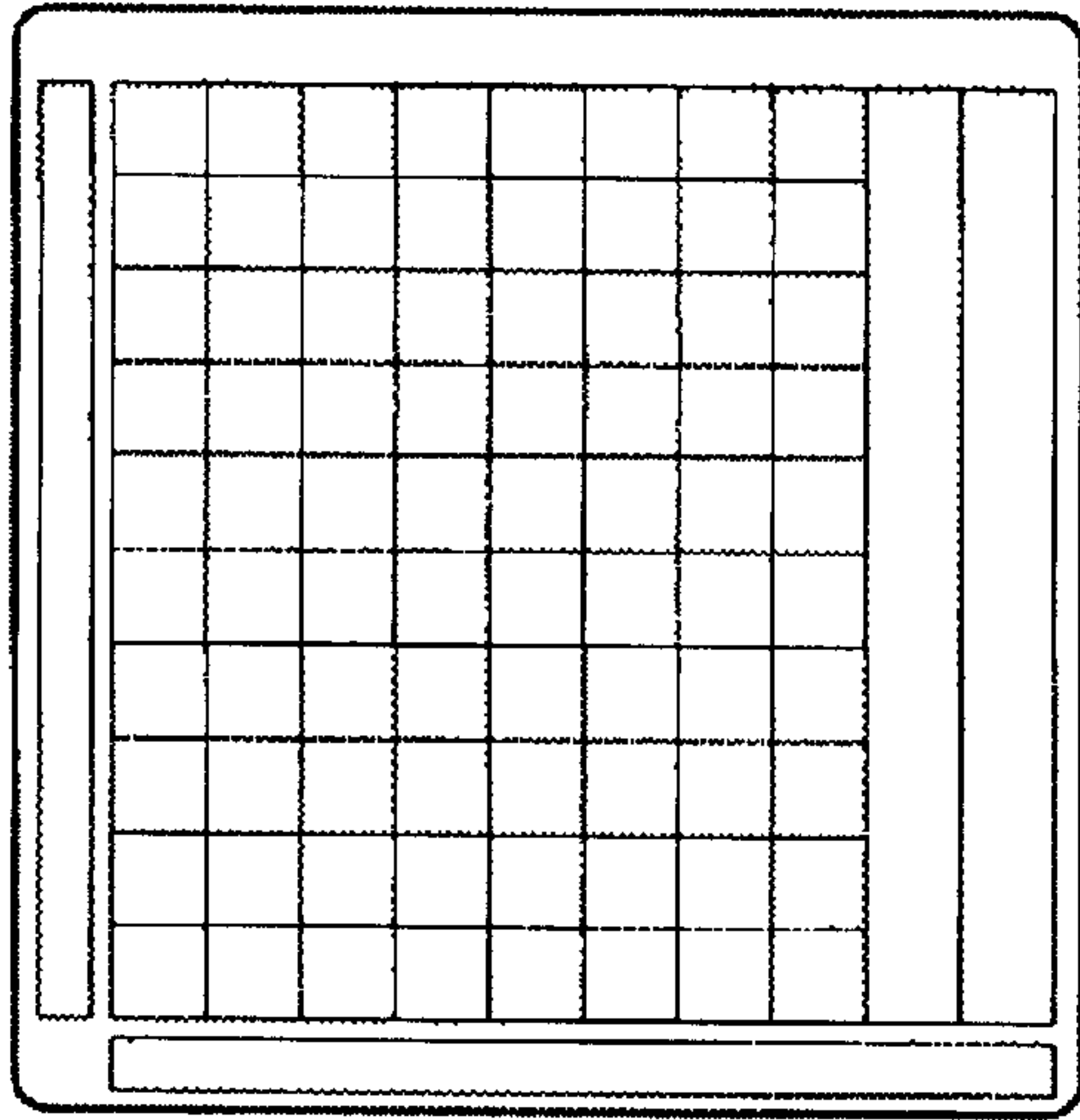

Fig. 5

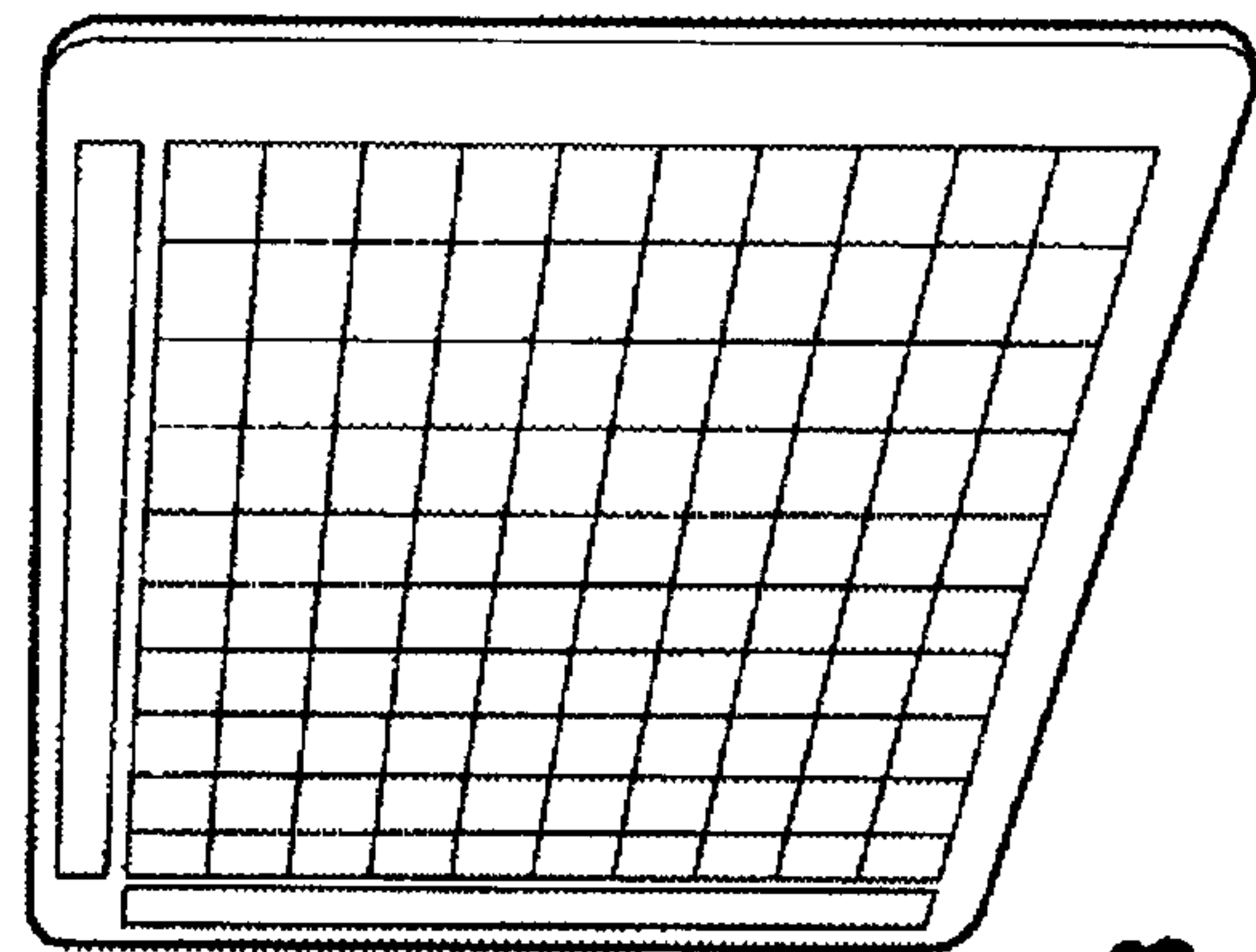

Fig. 3

Fig. 6

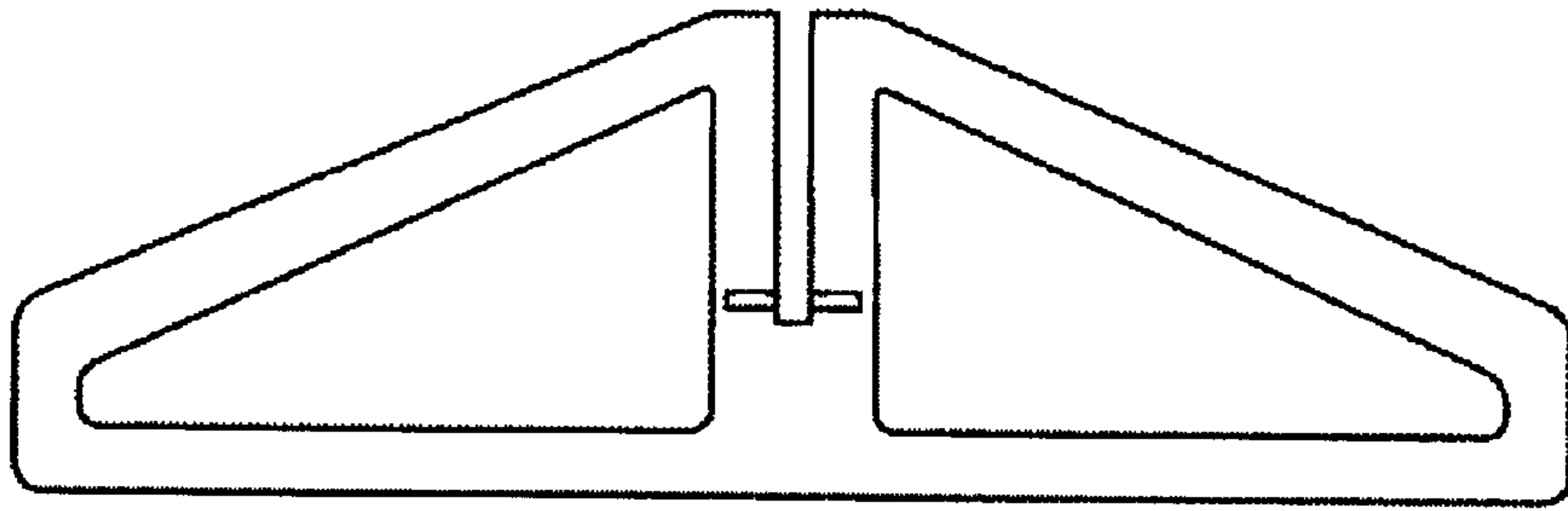

Fig. 7



Fig. 8

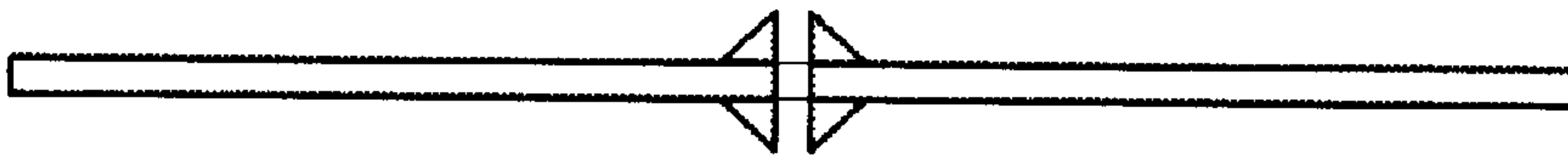

Fig. 9

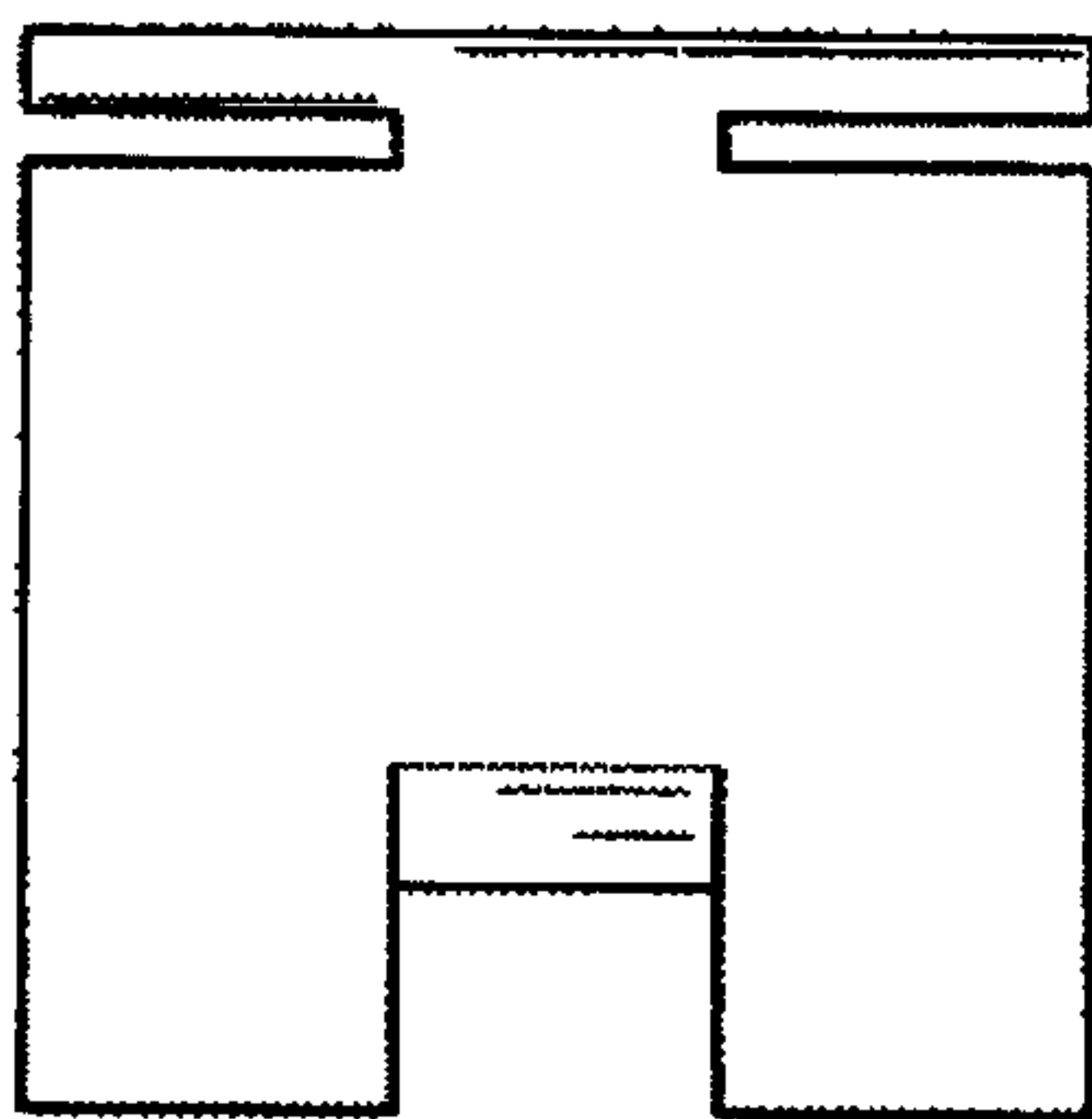

Fig. 12



Fig. 11

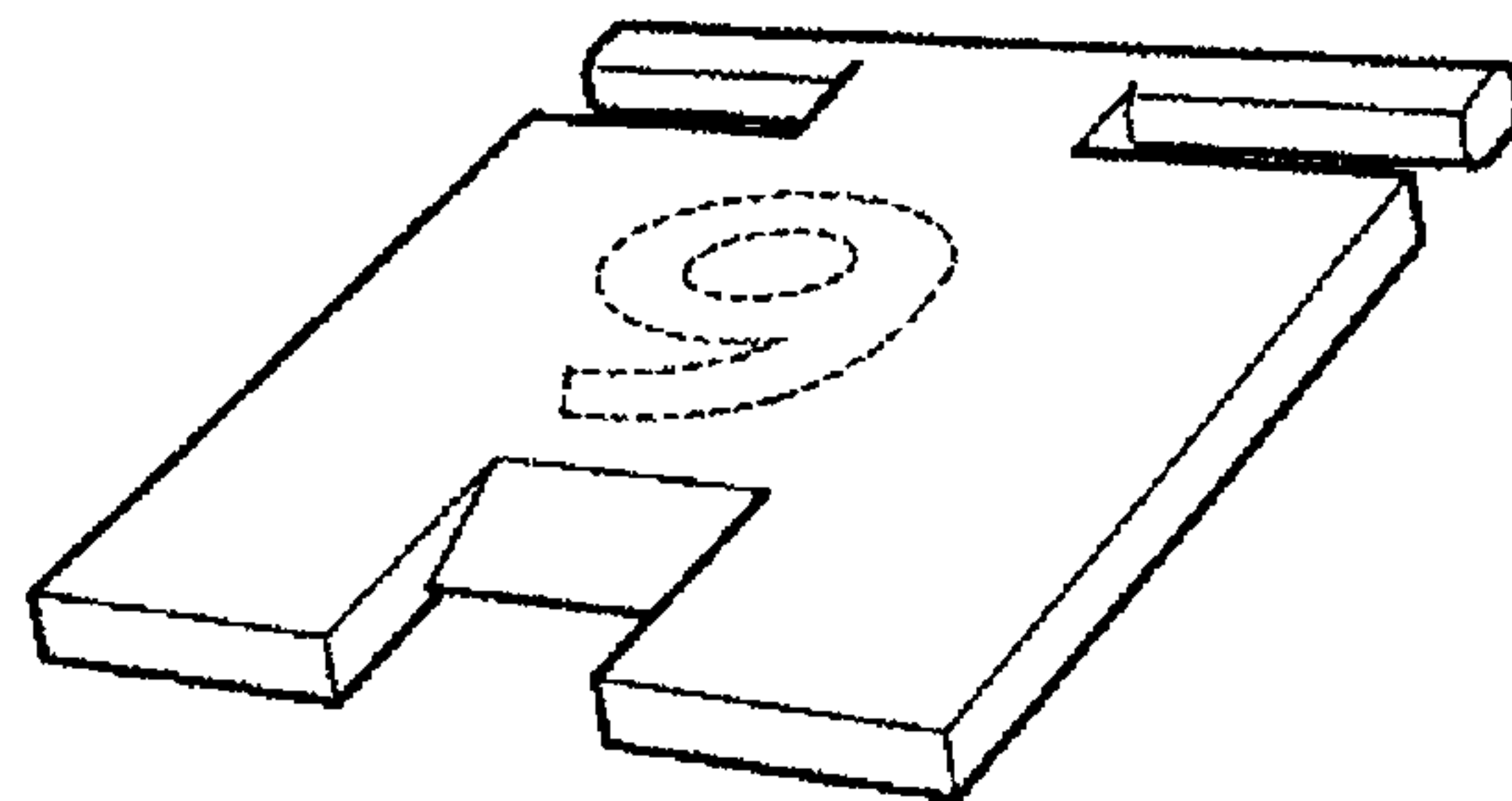

Fig. 10

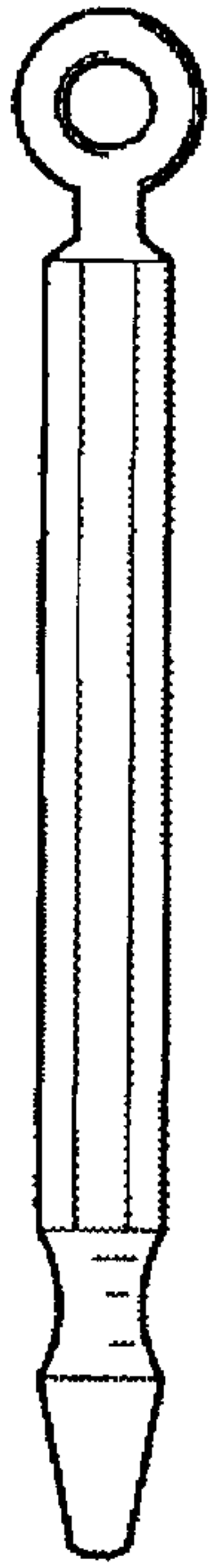

Fig. 15



Fig. 14

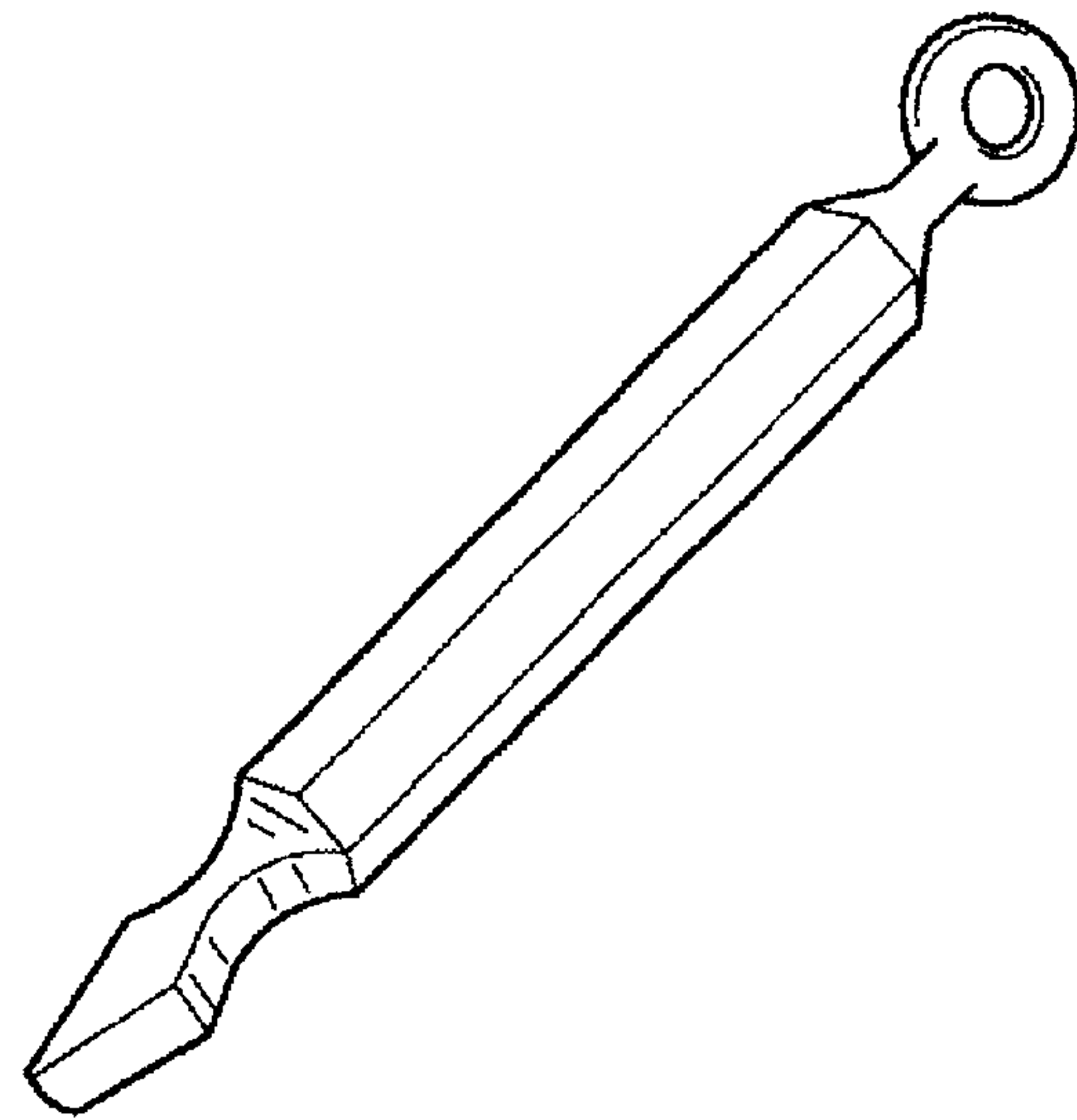

Fig. 13



Fig. 16



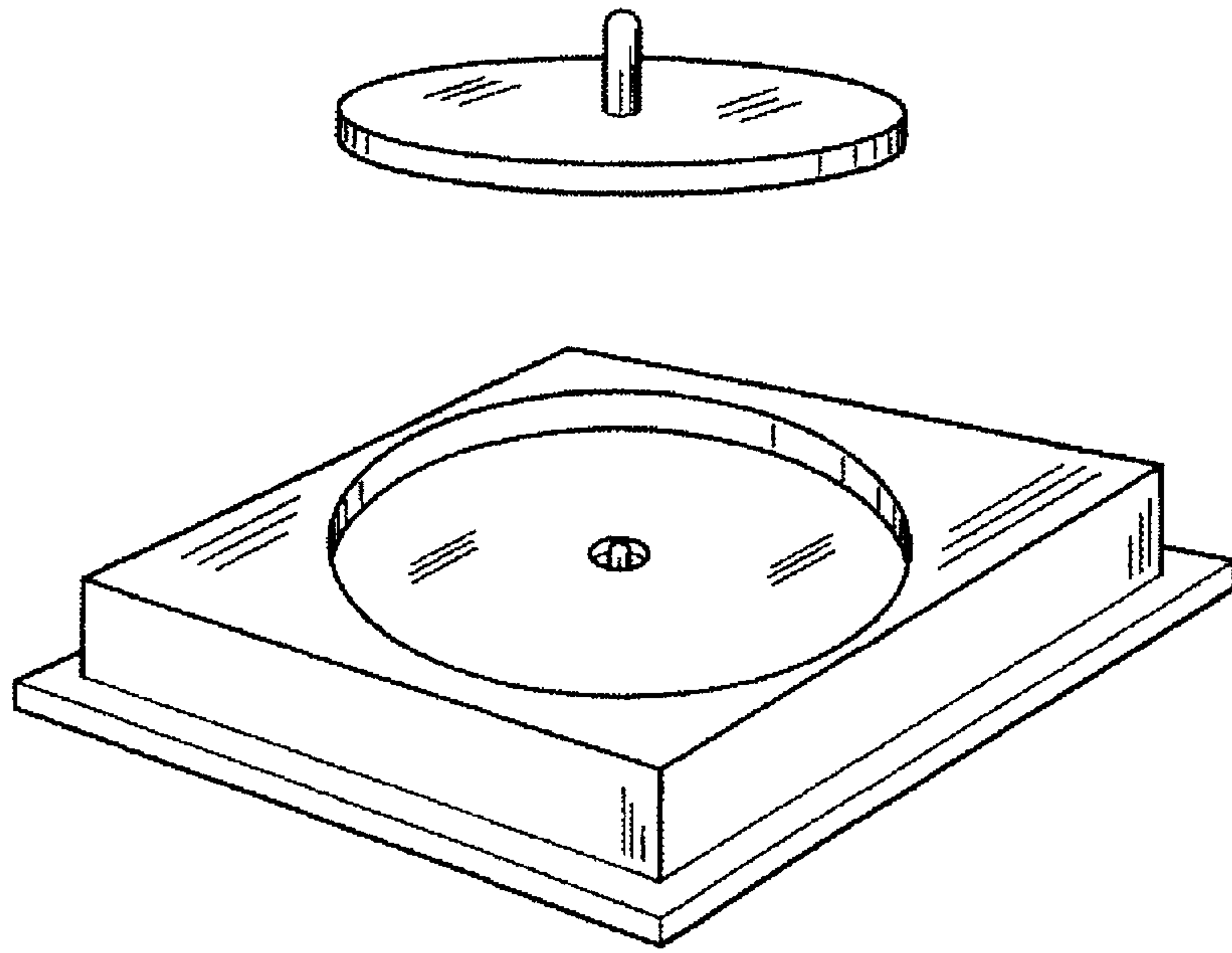

Fig. 17

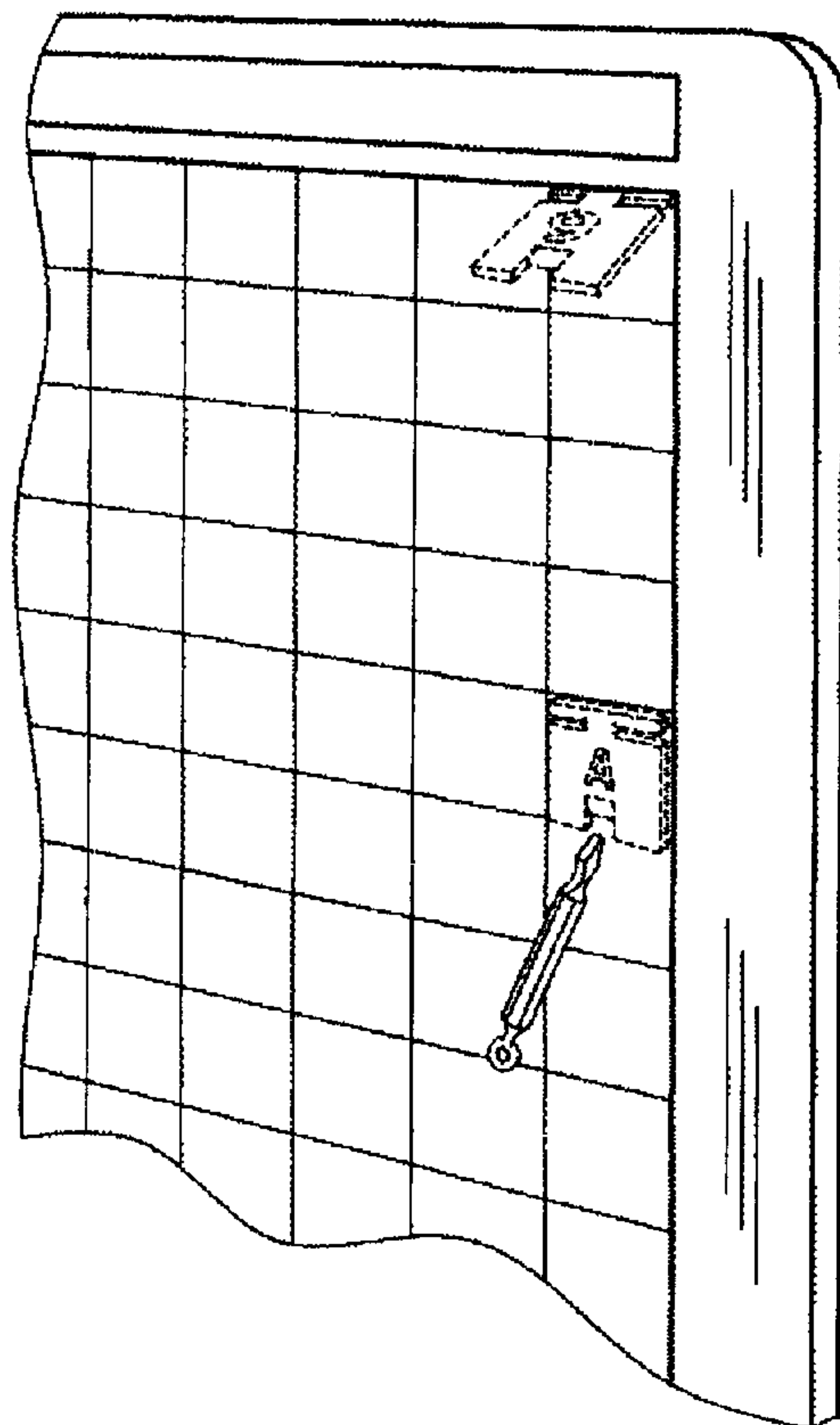

Fig. 18

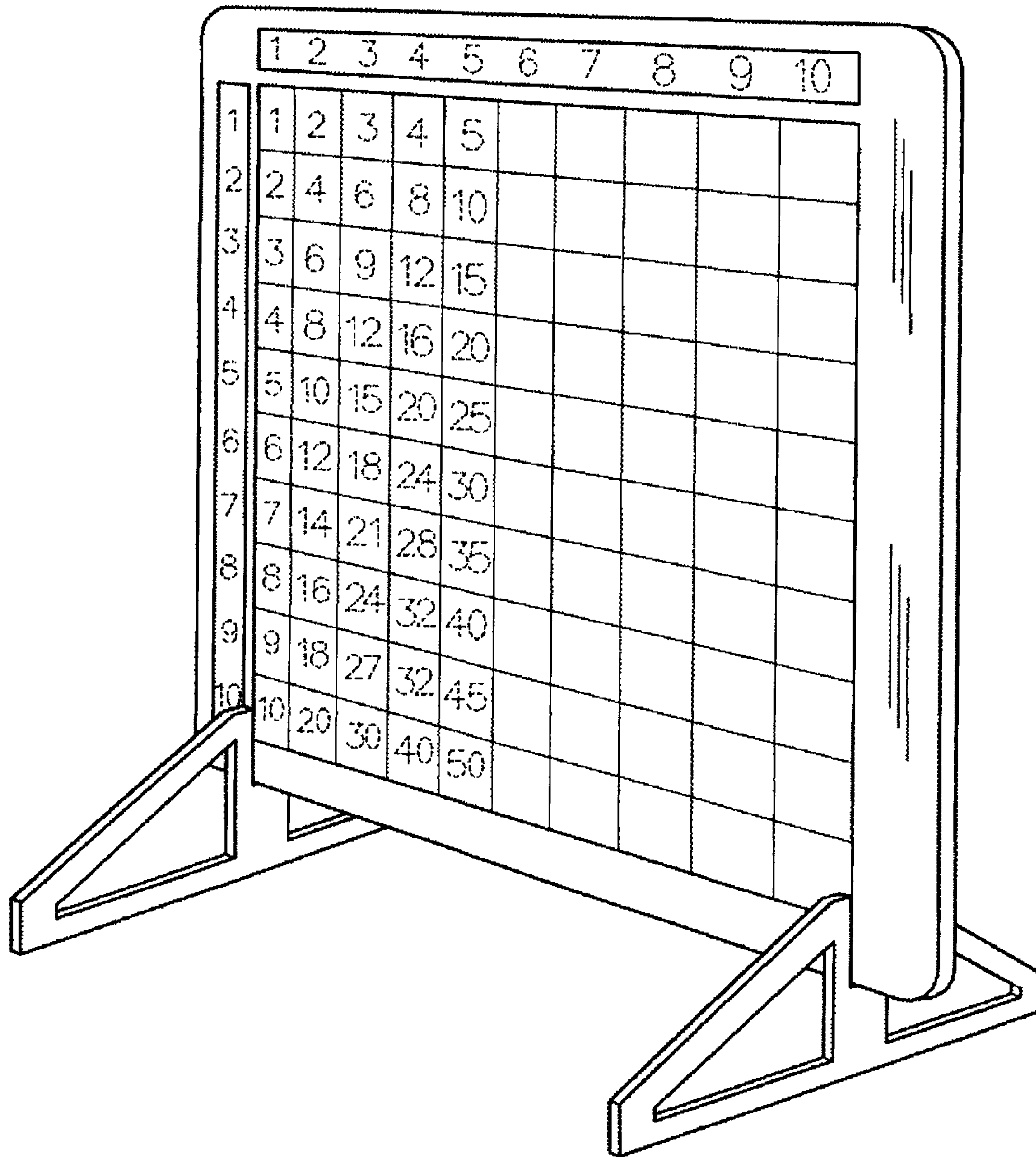

Fig. 19

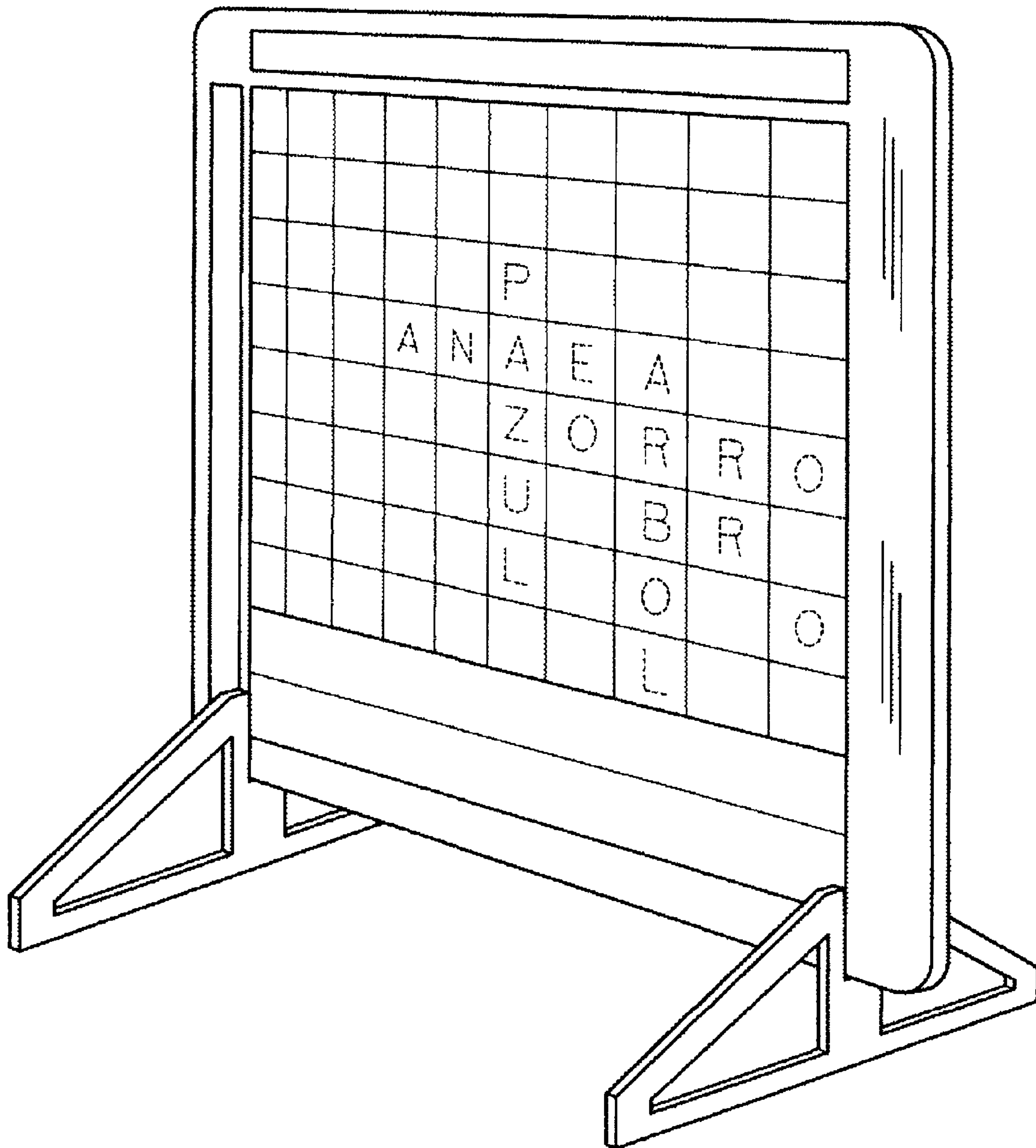

Fig. 20