



US00D539215S

(12) **United States Design Patent** (10) **Patent No.:** **US D539,215 S**  
**Yoshikawa et al.** (45) **Date of Patent:** **\*\* Mar. 27, 2007**

(54) **BATTERY**

(75) Inventors: **Toshiaki Yoshikawa**, Musashino (JP);  
**Yoshihide Ogino**, Higashikurume (JP)

(73) Assignee: **Daiwa Seiko, Inc.**, Tokyo (JP)

(\*\*) Term: **14 Years**

(21) Appl. No.: **29/252,086**

(22) Filed: **Jan. 19, 2006**

(30) **Foreign Application Priority Data**

Jul. 19, 2005 (JP) ..... 2005-021007

(51) **LOC (8) Cl.** ..... **13-02**

(52) **U.S. Cl.** ..... **D13/103**

(58) **Field of Classification Search** ..... D13/102–106,  
D13/110, 118–119, 184; 429/96–100, 163,  
429/176

See application file for complete search history.

(56) **References Cited**

**U.S. PATENT DOCUMENTS**

D124,726 S \* 1/1941 Shimer ..... D13/110  
5,240,787 A \* 8/1993 Goldschmidt et al. .... 429/97  
5,246,790 A \* 9/1993 Mooney et al. .... 429/7  
D400,160 S \* 10/1998 Nagano ..... D13/103  
D455,711 S \* 4/2002 Fuhr et al. .... D13/103  
D456,003 S \* 4/2002 Fuhr et al. .... D13/103  
D471,515 S \* 3/2003 Kasahara et al. .... D13/103

D471,862 S \* 3/2003 Kasahara et al. .... D13/103  
D471,864 S \* 3/2003 Katsumoto et al. .... D13/103  
D486,445 S \* 2/2004 Kasahara et al. .... D13/103  
6,777,130 B2 \* 8/2004 Kasahara et al. .... 429/176  
2003/0017389 A1 \* 1/2003 Kasahara et al. .... 429/176  
2003/0134192 A1 \* 7/2003 Katsumoto et al. .... 429/176

**FOREIGN PATENT DOCUMENTS**

JP 1001929 S 1/1998  
JP 1032751 S 2/1999  
JP 1105171 S 4/2001  
JP 1139782 S 4/2002

\* cited by examiner

*Primary Examiner*—Alan P. Douglas

*Assistant Examiner*—Rosemary K. Tarcza

(74) *Attorney, Agent, or Firm*—Sughrue Mion, PLLC

(57) **CLAIM**

The ornamental design for a battery, as shown.

**DESCRIPTION**

FIG. 1 is a perspective view of a top, front and right side of a battery showing our new design;

FIG. 2 is a front elevational view thereof;

FIG. 3 is a rear elevational view thereof;

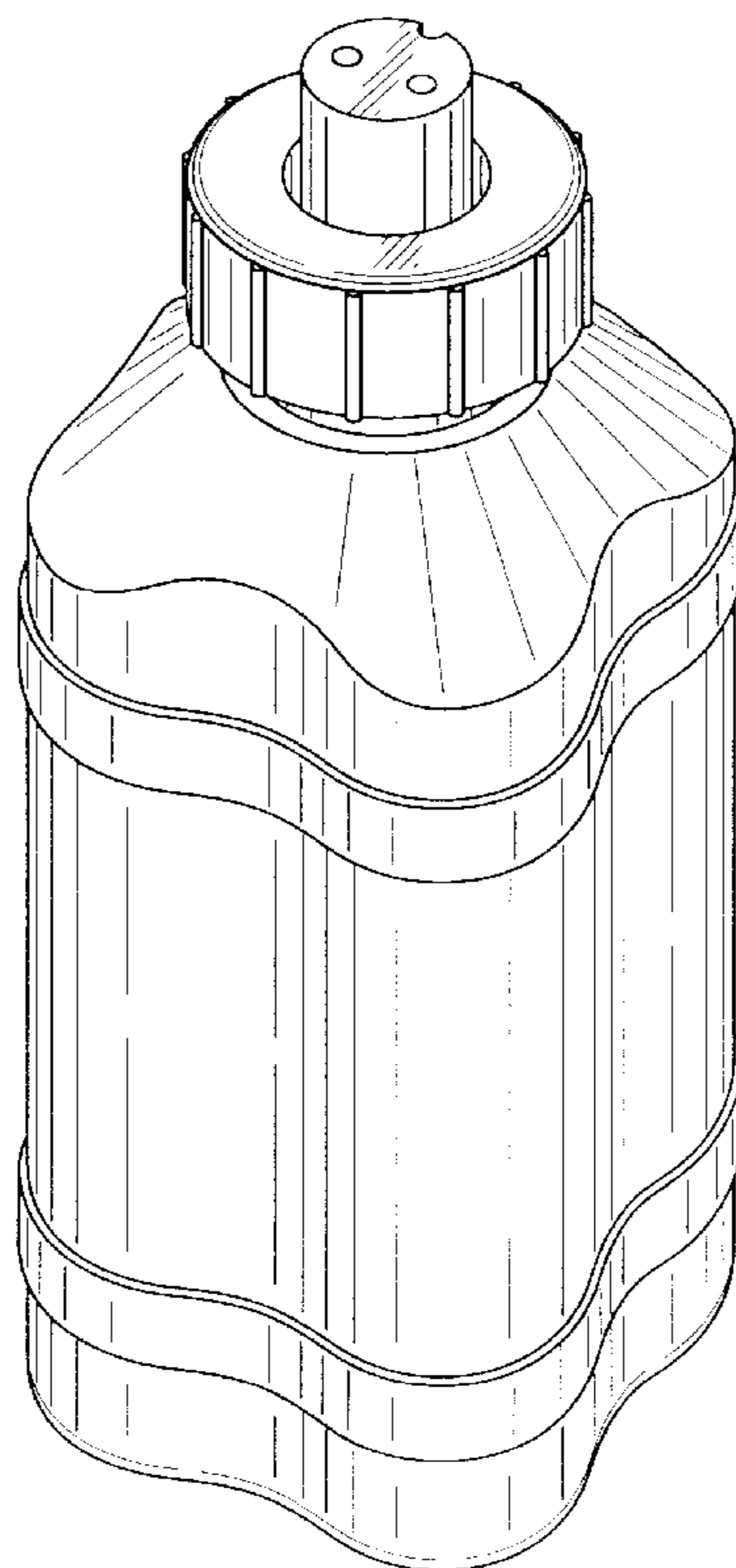
FIG. 4 is a right side elevational view thereof;

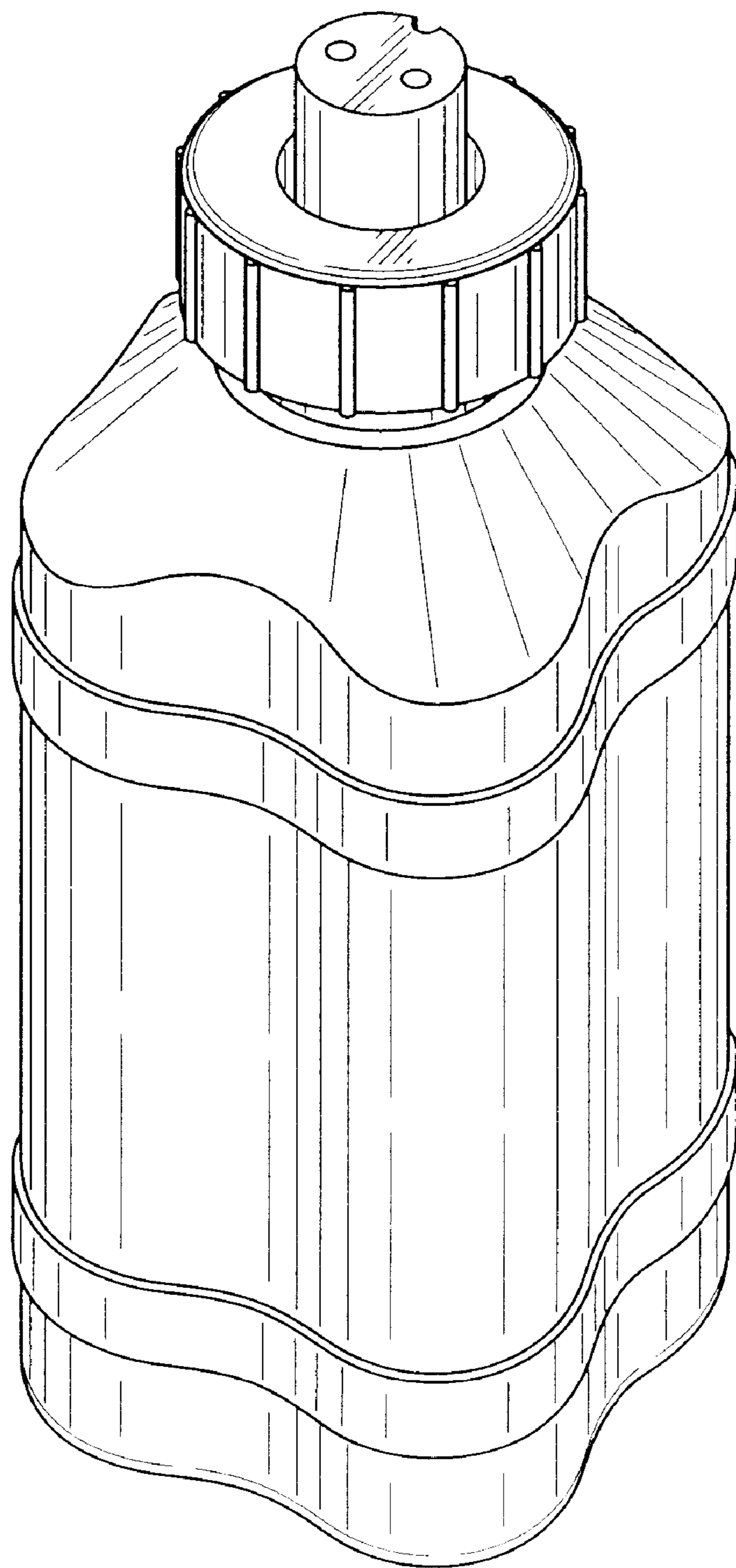
FIG. 5 is a left side elevational view thereof;

FIG. 6 is a top plan view thereof; and,

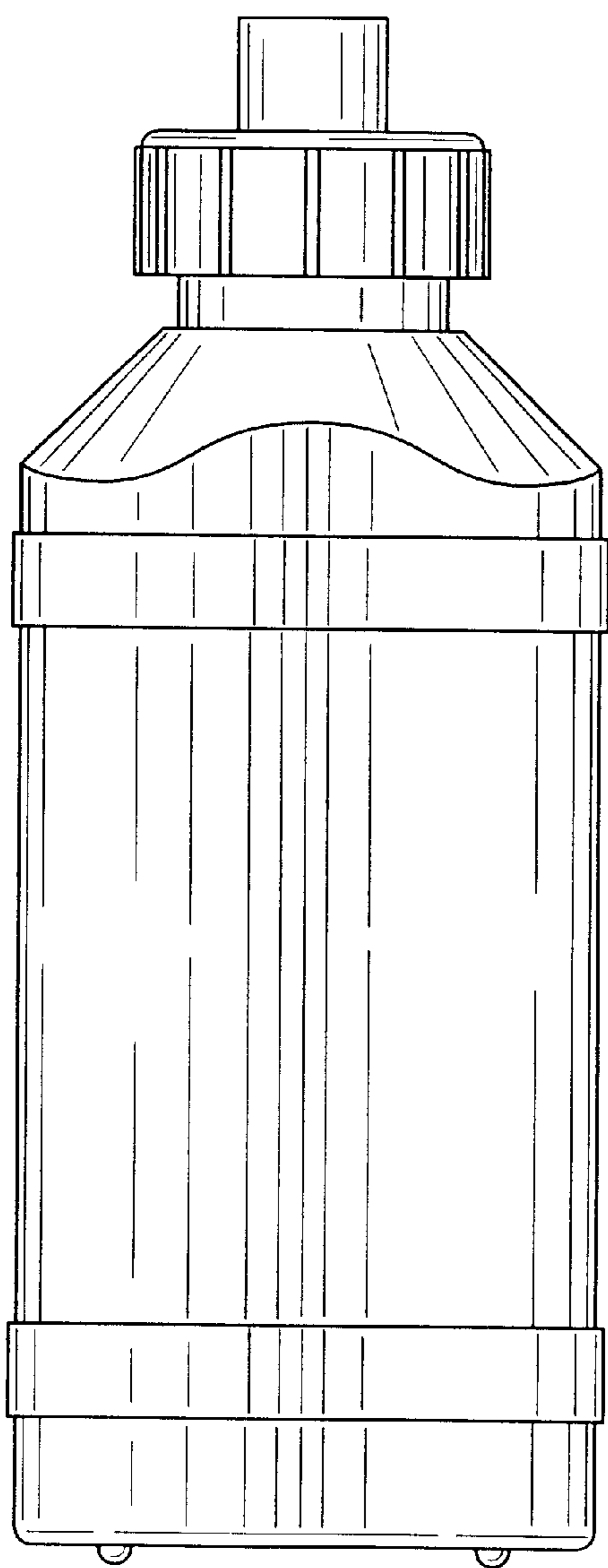
FIG. 7 is a bottom plan view thereof.

**1 Claim, 4 Drawing Sheets**

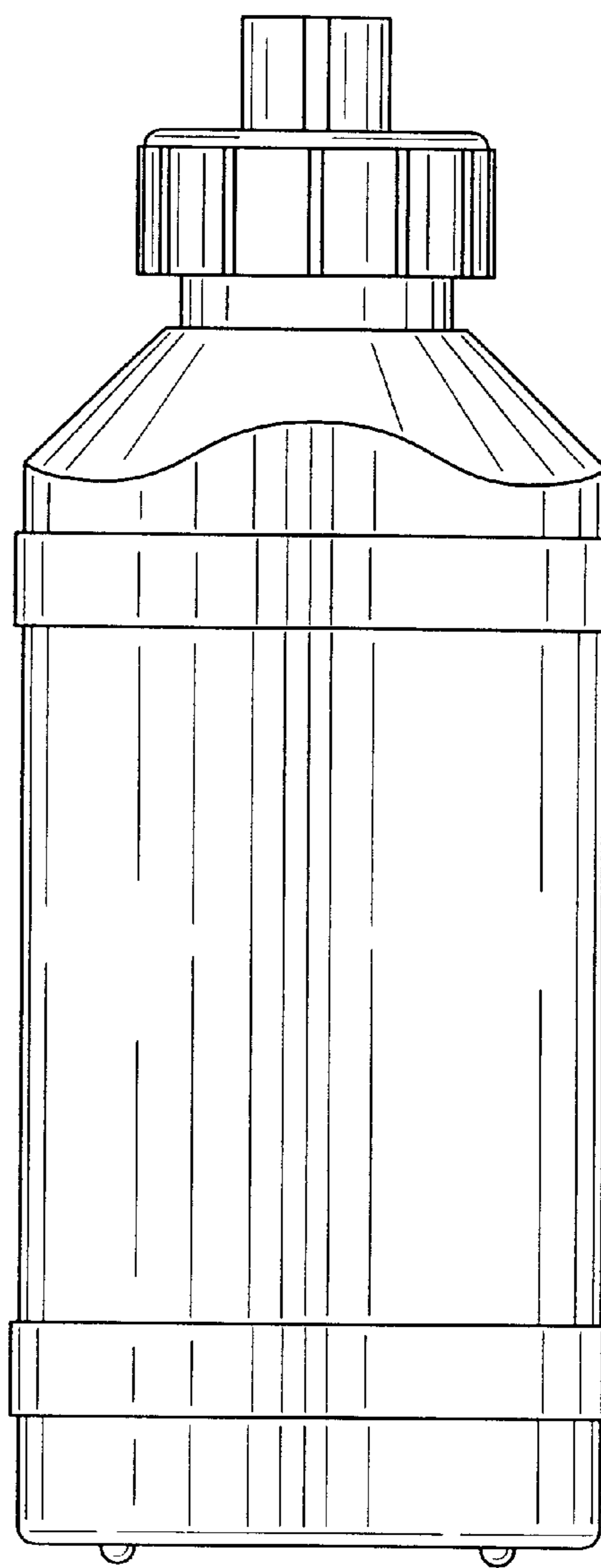




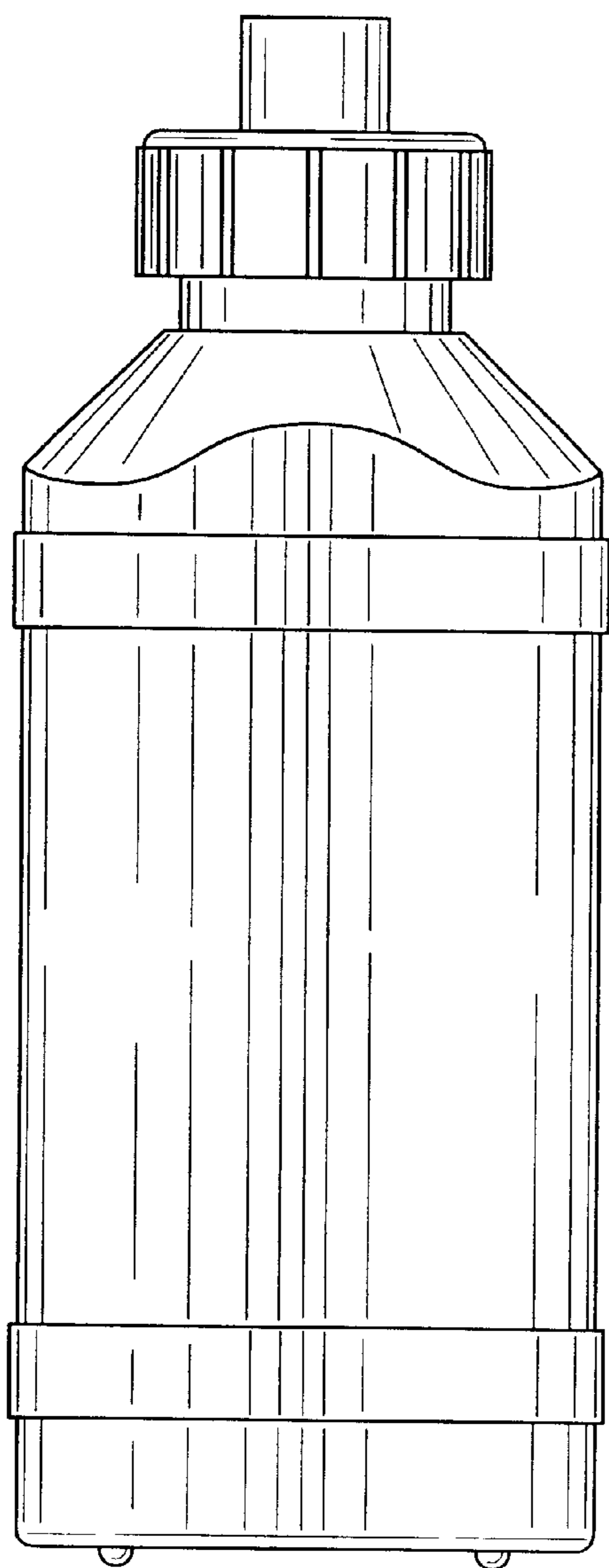
*FIG. 1*



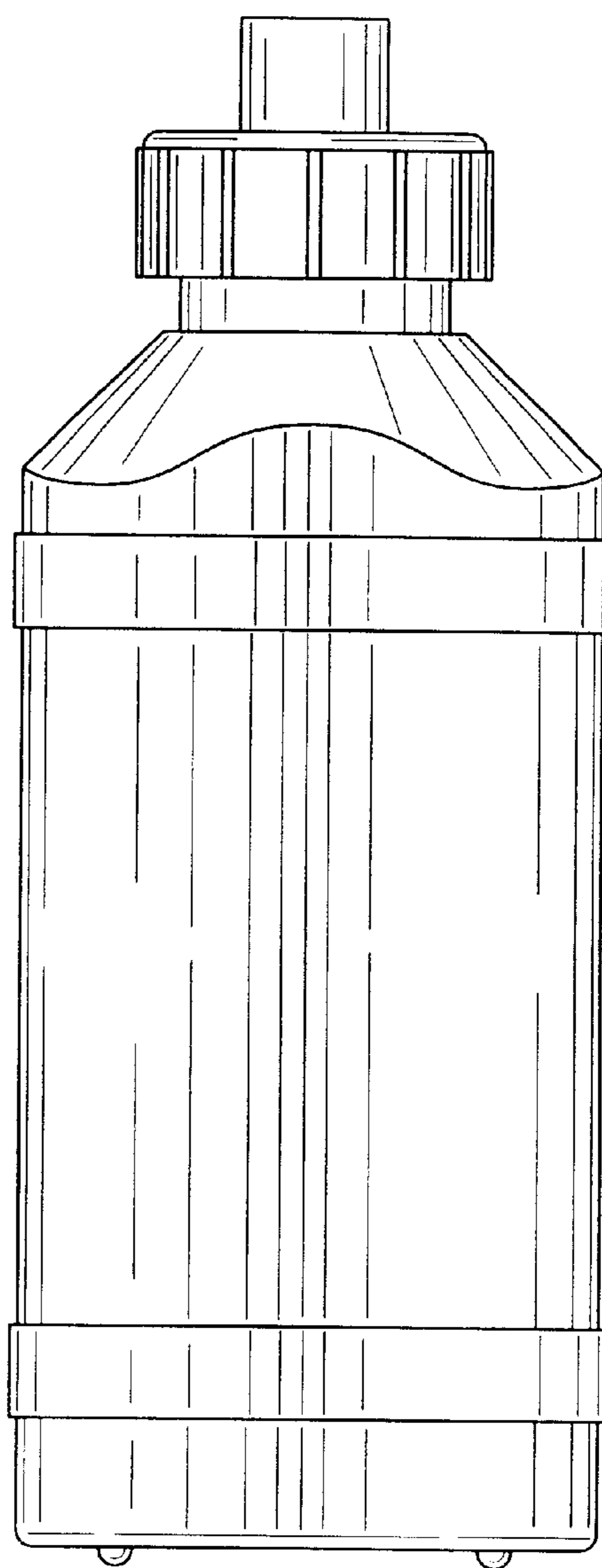
*FIG. 2*



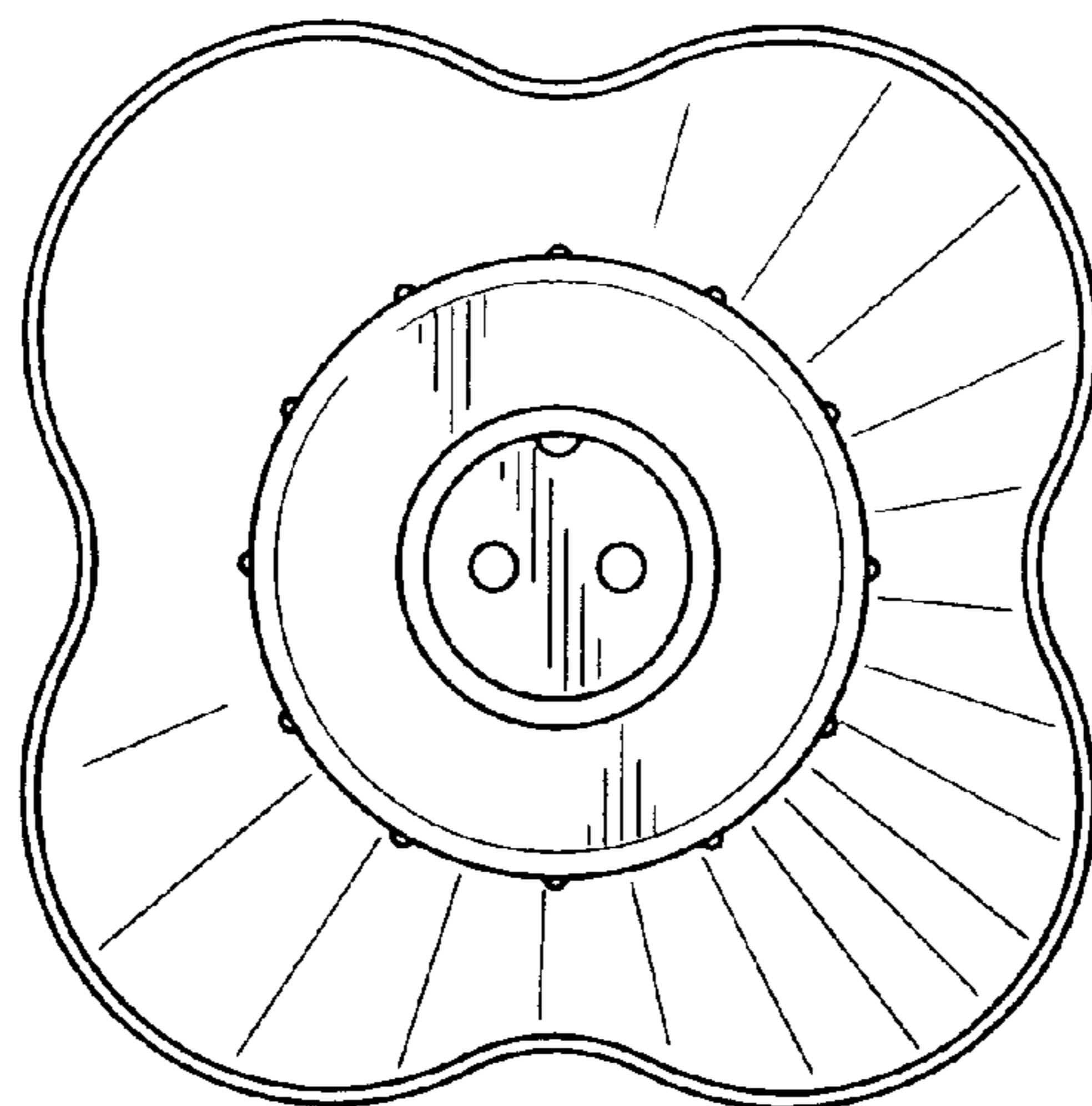
*FIG. 3*



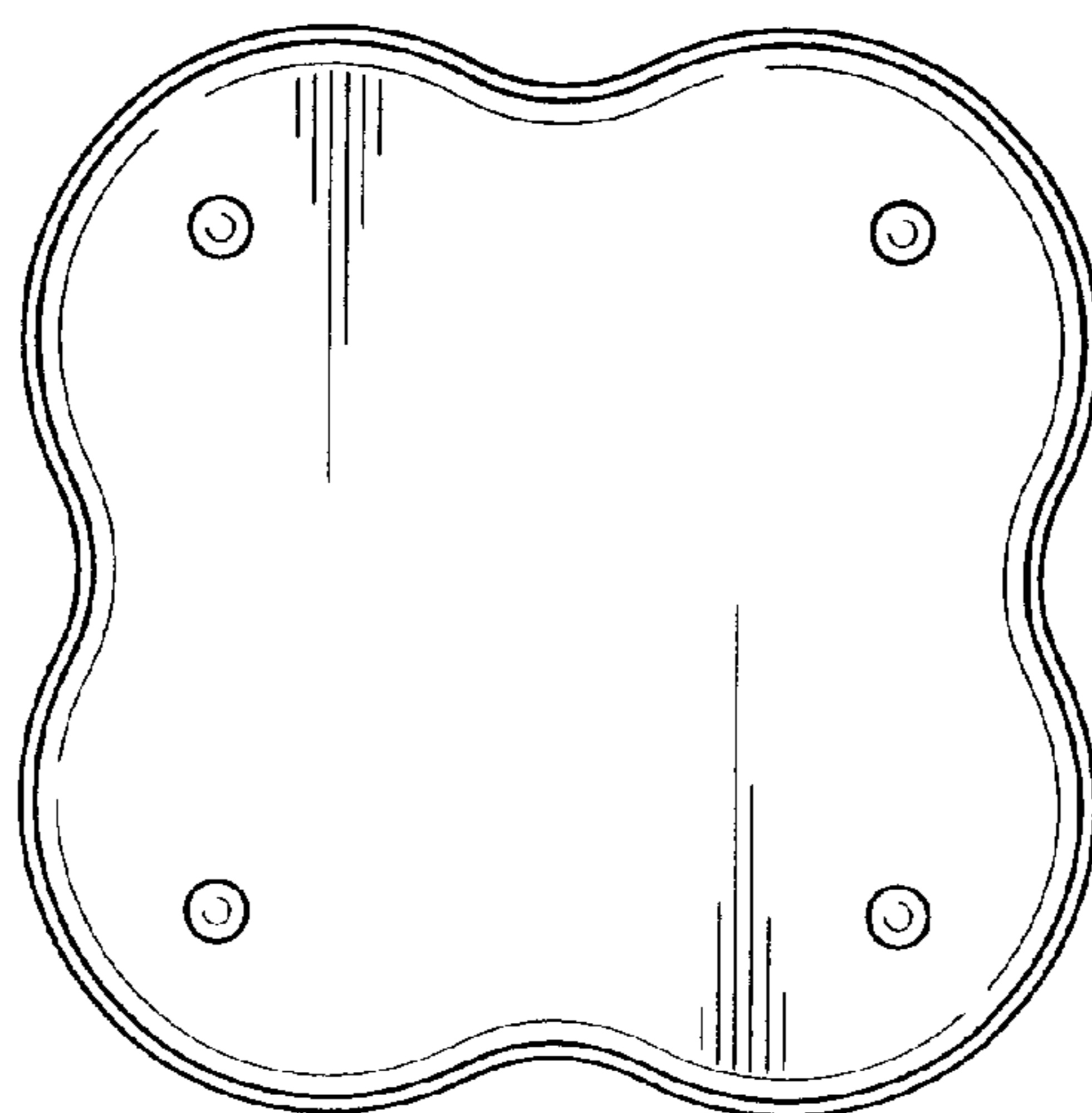
*FIG. 4*



*FIG. 5*



*FIG. 6*



*FIG. 7*