



US00D539198S

(12) **United States Design Patent**  
**Sands**

(10) **Patent No.:** **US D539,198 S**

(45) **Date of Patent:** **\*\* Mar. 27, 2007**

(54) **TWO-PART MID-CONTROL UNIT FOR A RIGHT-SIDE DRIVE MOTORCYCLE**

(75) Inventor: **Perry W. Sands**, La Palma, CA (US)

(73) Assignee: **Performance Machine, Inc.**, La Palma, CA (US)

(\*\*) Term: **14 Years**

(21) Appl. No.: **29/236,639**

(22) Filed: **Aug. 19, 2005**

(51) **LOC (8) Cl.** ..... **12-16**

(52) **U.S. Cl.** ..... **D12/179**

(58) **Field of Classification Search** ..... D12/110,  
D12/114, 122, 125, 179; 74/512, 564, 474,  
74/478, 562, 562.5, 473.16, 473.17, 473.2;  
180/219, 336, 291-294, 230; 296/75; 280/291;  
192/3.61, 48.1, 3.54, 48.3, 48.7, 99 S  
See application file for complete search history.

(56) **References Cited**

**U.S. PATENT DOCUMENTS**

7,040,442 B2 \* 5/2006 McWhorter ..... 180/219

**OTHER PUBLICATIONS**

Custom Chrome® Chrome Specialties® 2003 catalog, Forward Control Kits by Billet Concepts, Legends, and Pro-One™ on p. 3.04.\*

Drag Specialties 2003 catalog, Billet Aluminum Forward Controls shown and described on p. 785.\*

\* cited by examiner

*Primary Examiner*—Alan P. Douglas

*Assistant Examiner*—Linda Brooks

(74) *Attorney, Agent, or Firm*—David Pressman

(57) **CLAIM**

The ornamental design for a two-part mid-control unit for a right-side drive motorcycle, as shown and described.

**DESCRIPTION**

FIG. 1 shows a perspective view taken from above and from the front of a two-part mid-control unit for a right-side drive motorcycle. The unit consists of a left half, shown in the foreground and right side of the figure and a right half, shown in the rear and left side of the figure. The two halves are installed on the middle, lower part of a motorcycle in the relative positions indicated.

FIGS. 2 and 3 are side elevational views of the left half taken from the left (outside) and right (inside) sides, respectively. FIGS. 4 and 5 are top and bottom views, respectively, of the left half.

FIGS. 6 and 7 are rear and front views, respectively, of the left half.

FIGS. 8 and 9 are side elevational views of the right half taken from the right (inside) and right (outside) sides, respectively.

FIGS. 10 and 11 are top and bottom views, respectively, of the right half; and,

FIGS. 12 and 13 are rear and front views, respectively, of the right half.

The left and right halves of the two-part mid-control unit for a right-side drive motorcycle are shown separately in FIGS. 2 to 13 for clarity of illustration.

**1 Claim, 7 Drawing Sheets**

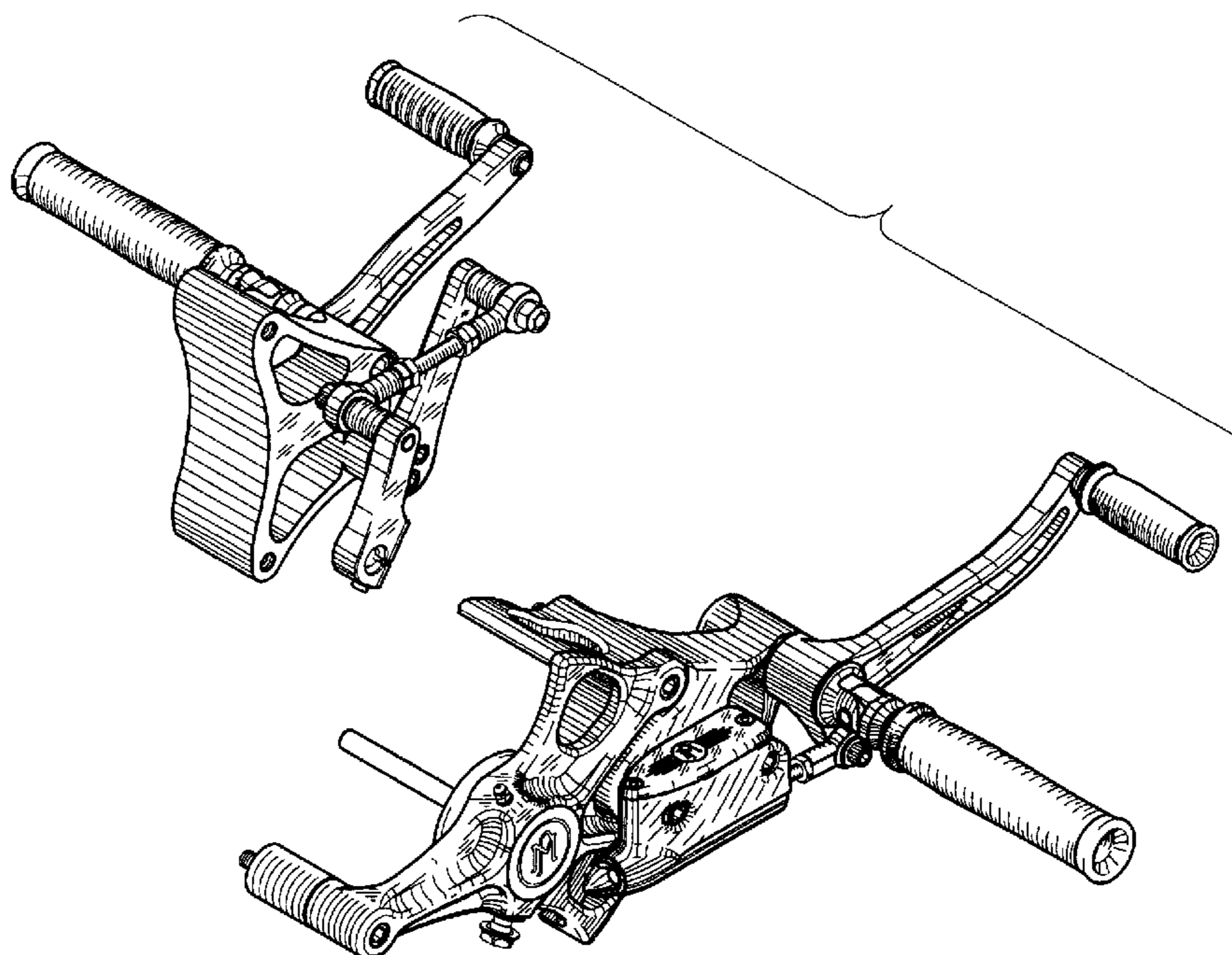

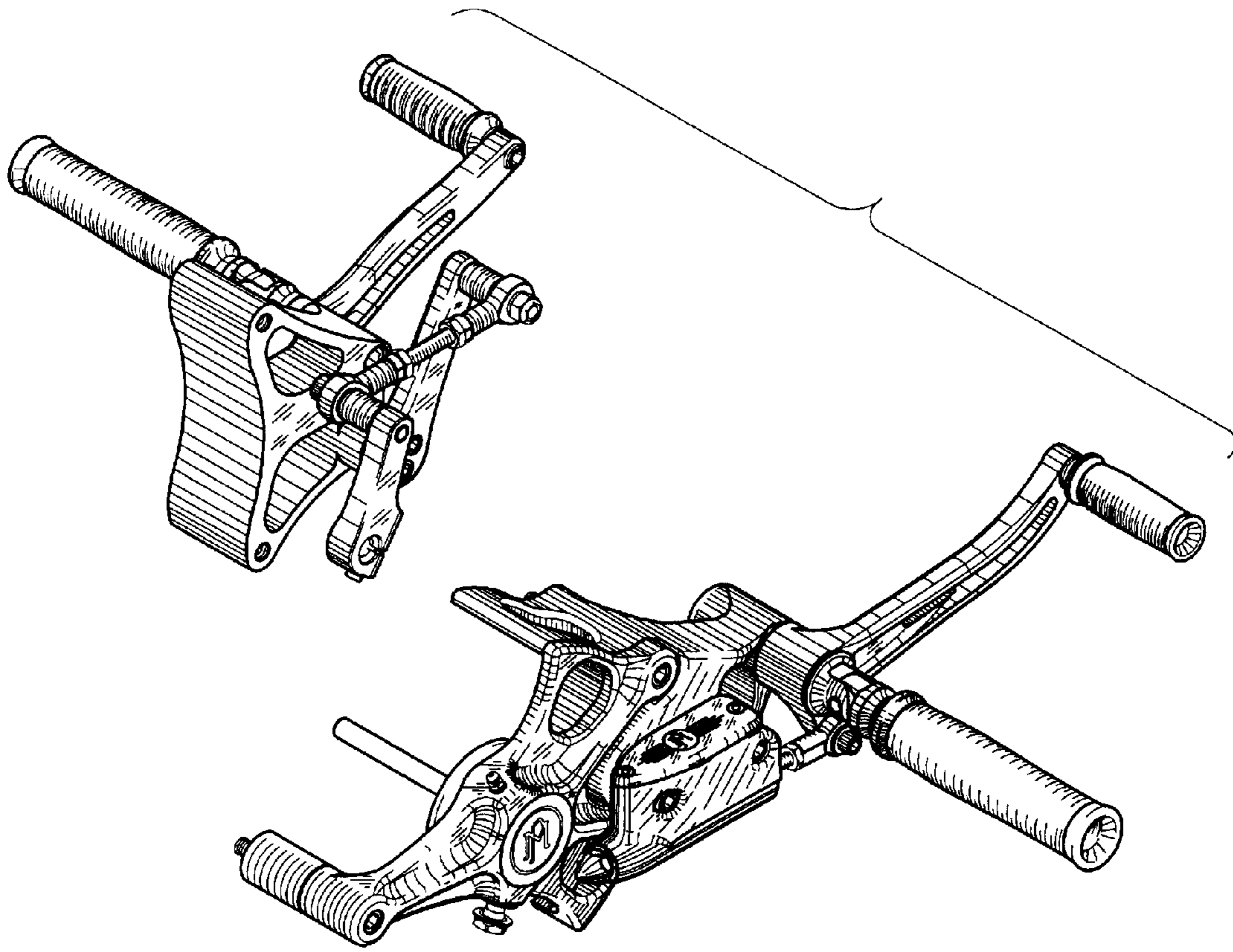

FIG 1

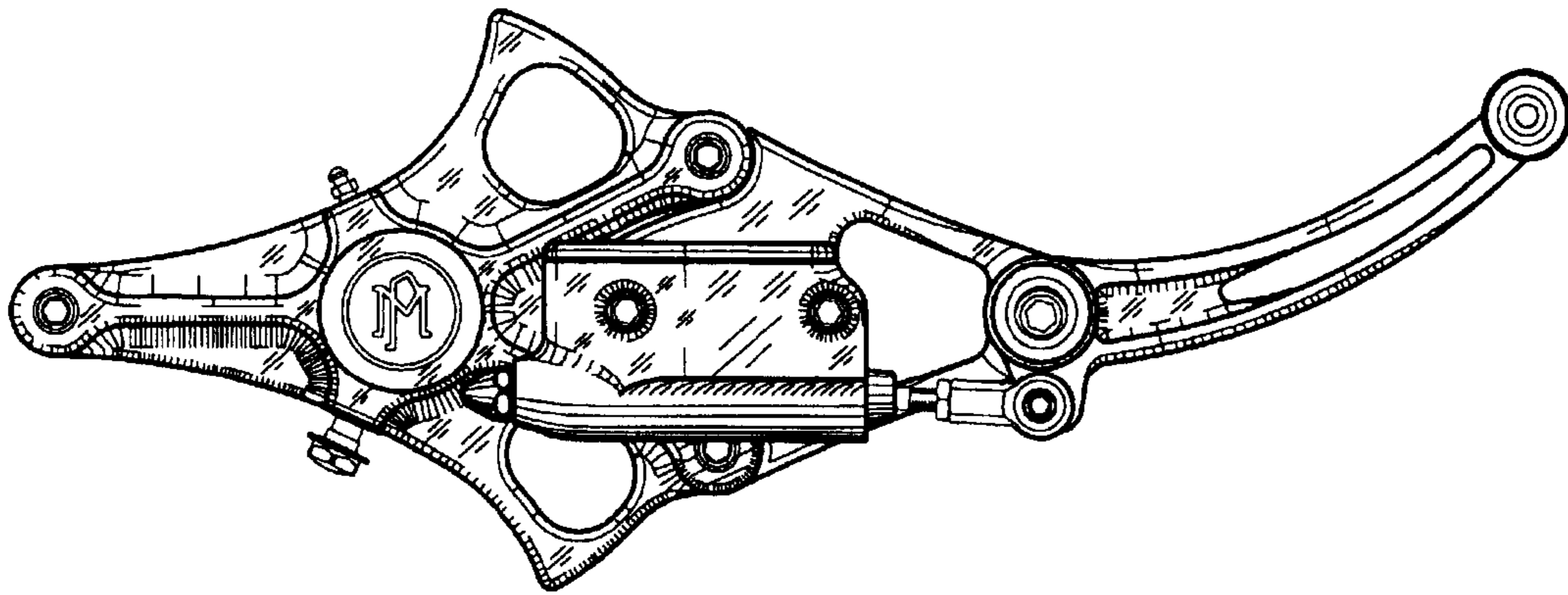

FIG 2

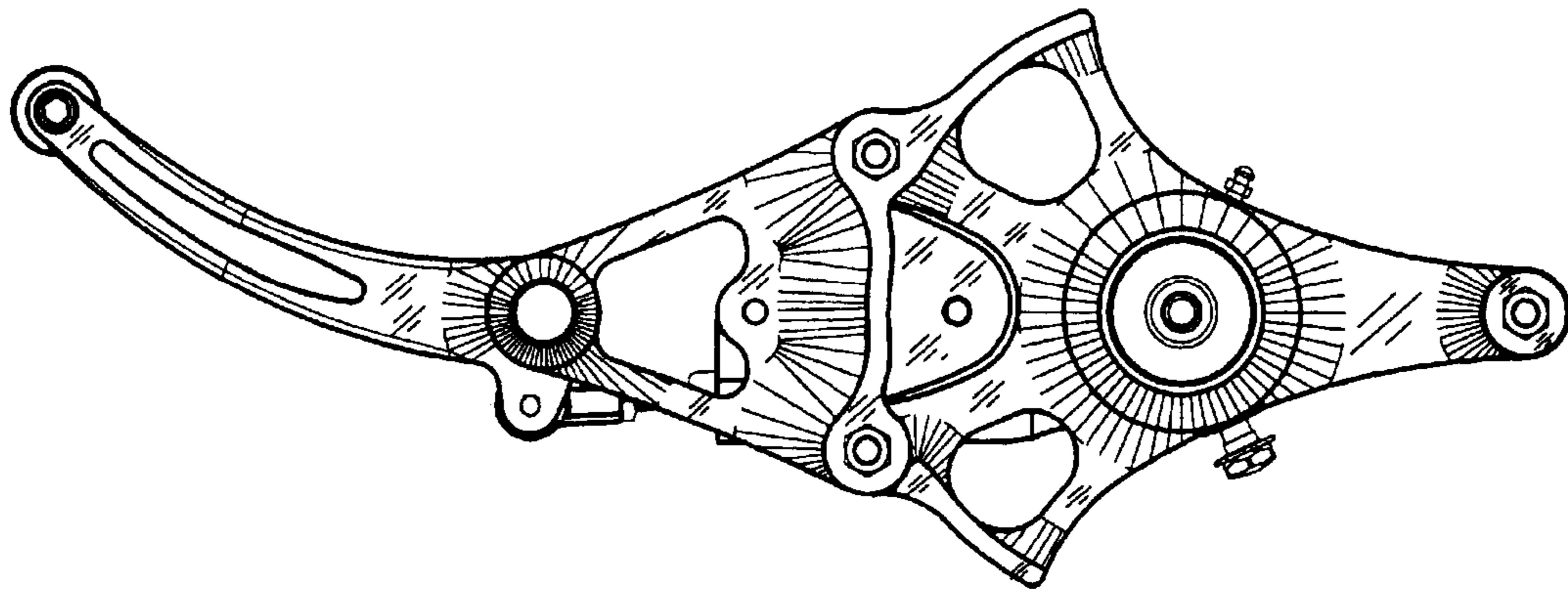

FIG 3



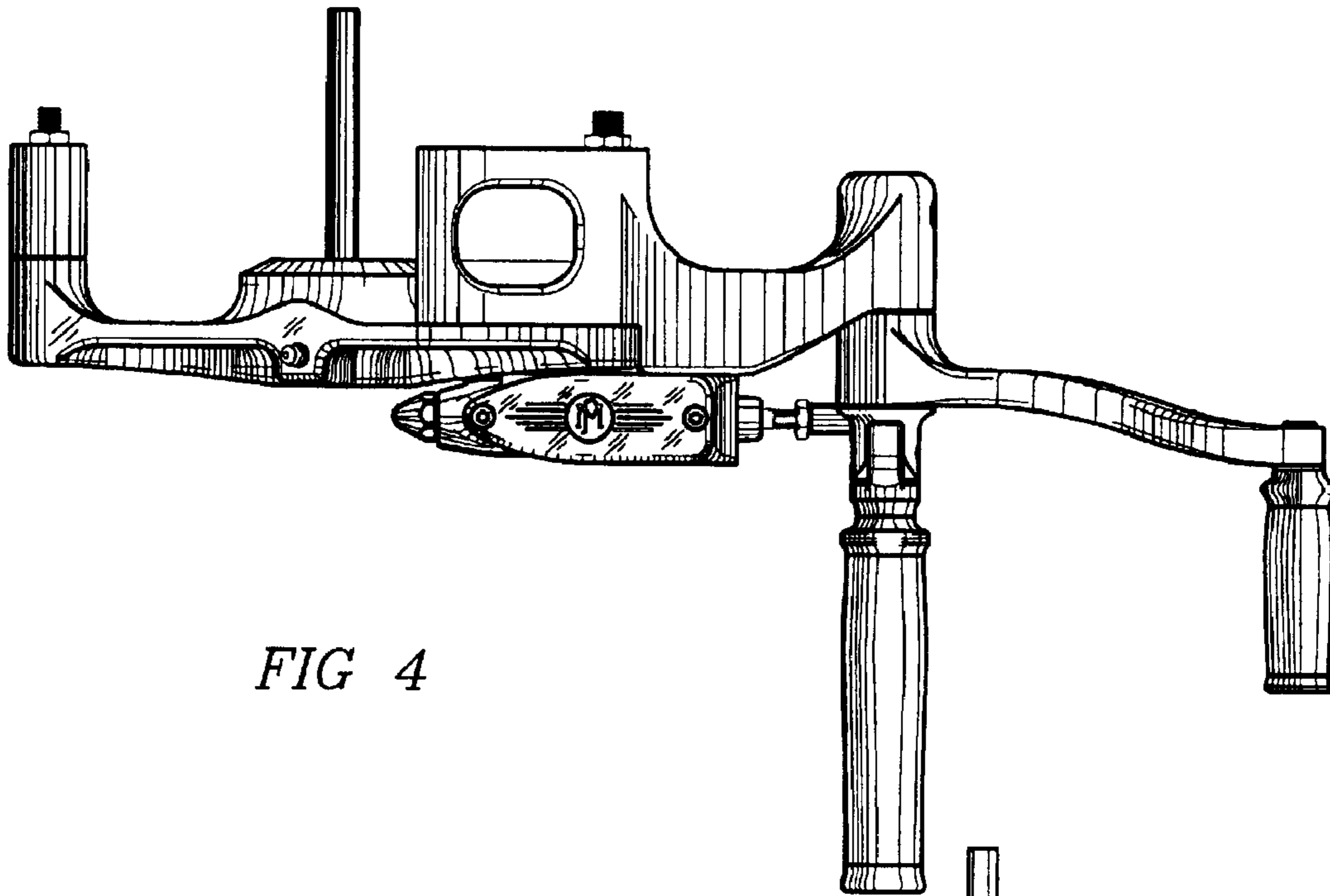

FIG 4

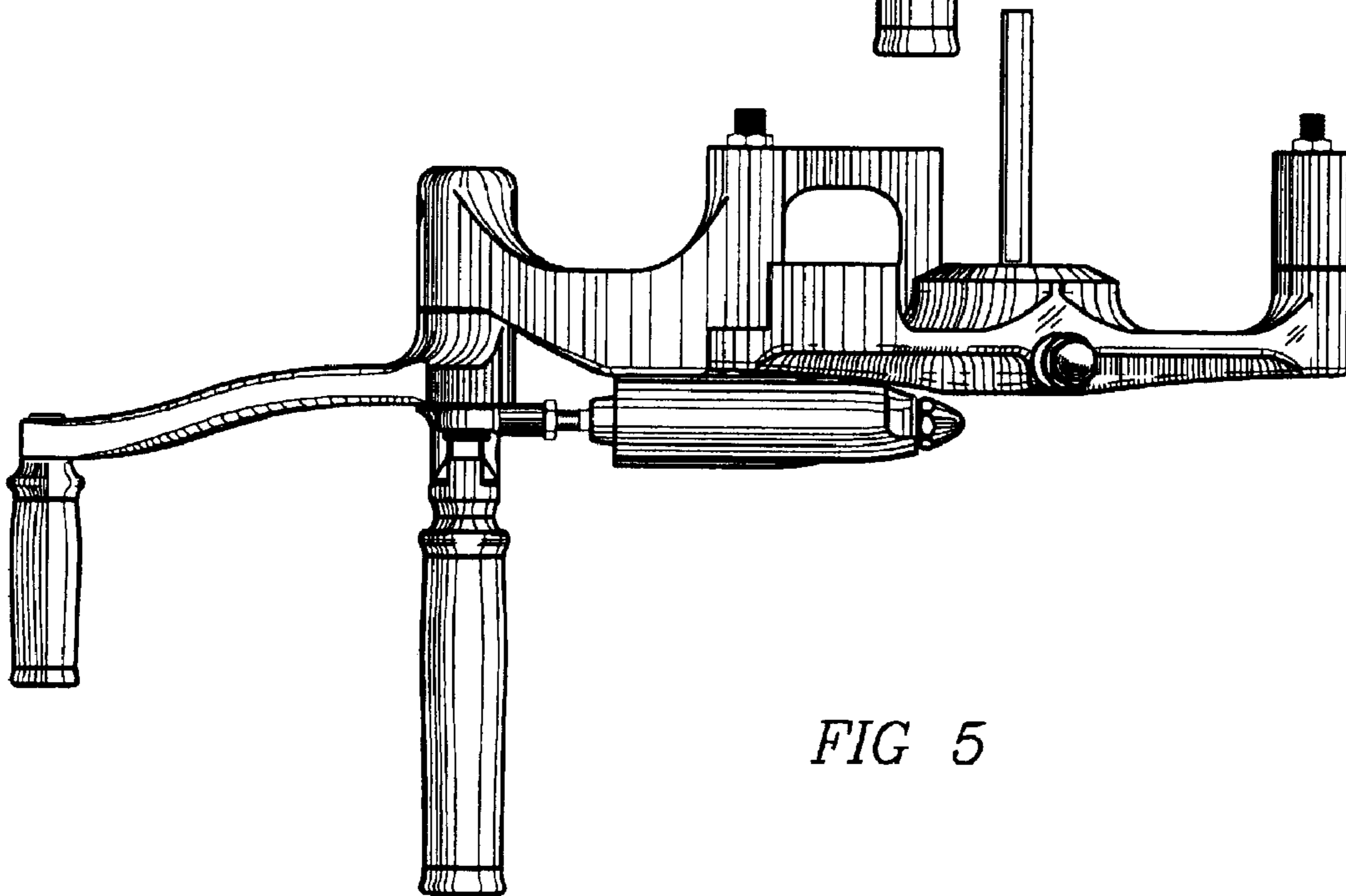

FIG 5

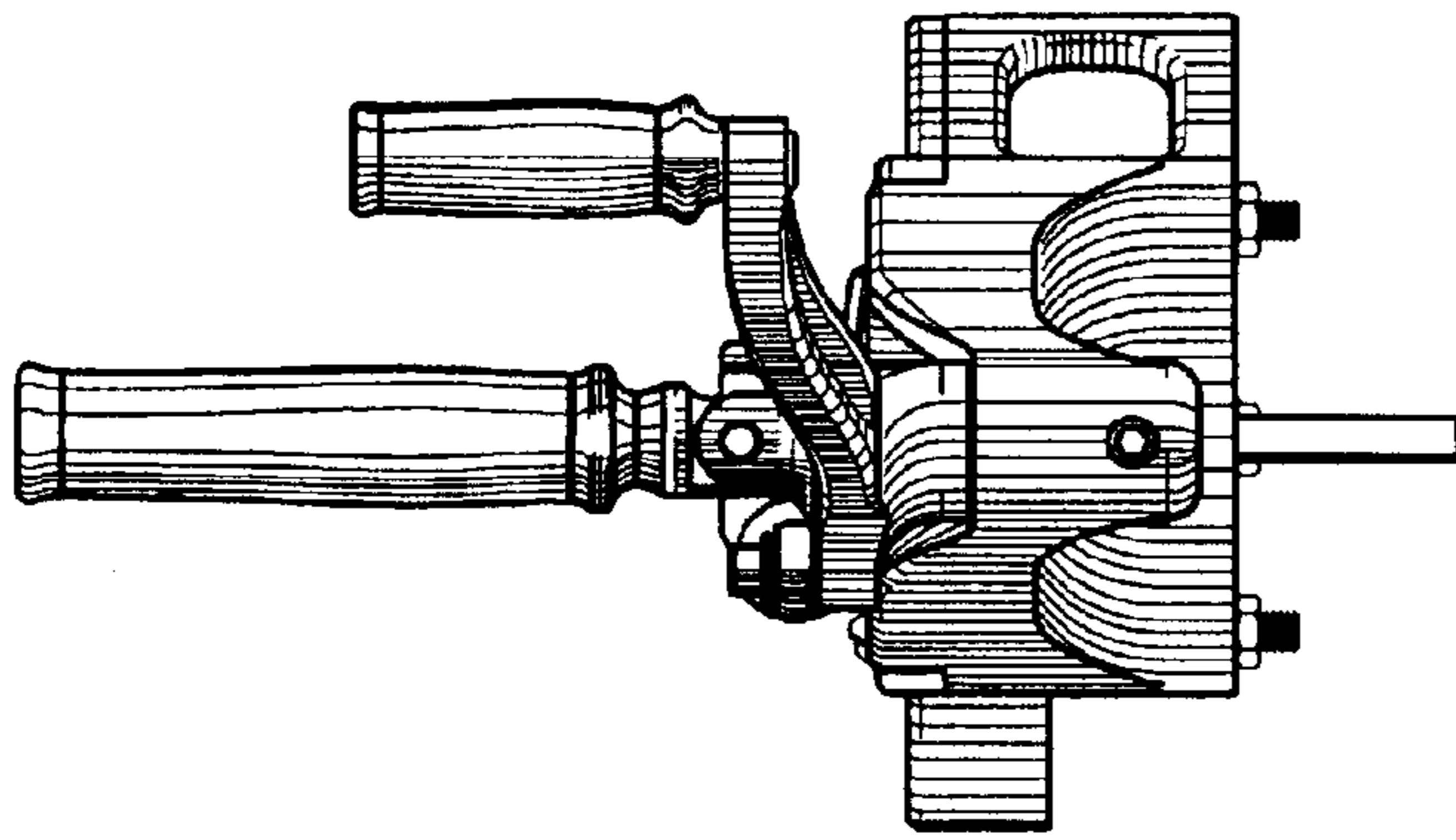

FIG 6

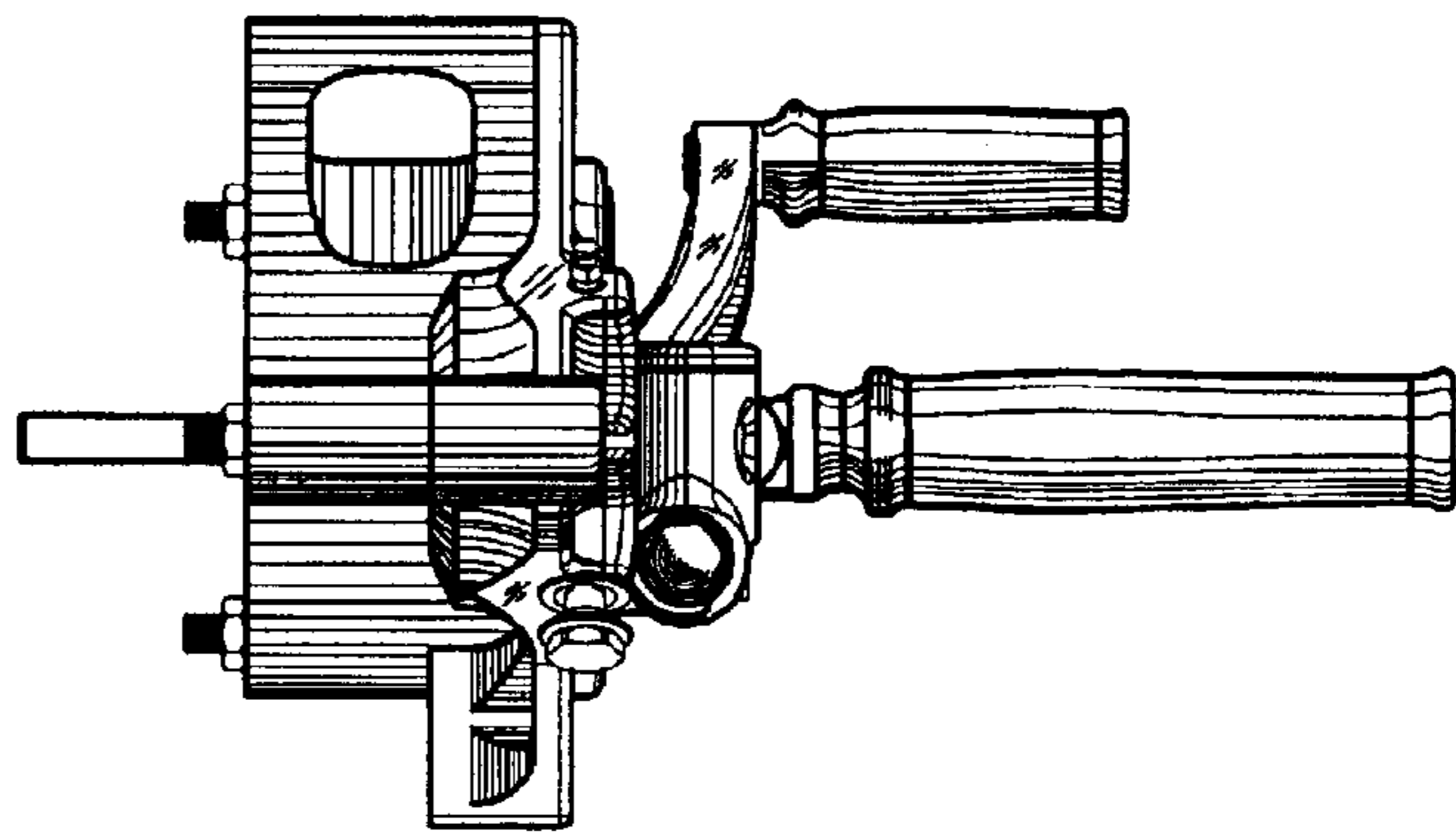

FIG 7

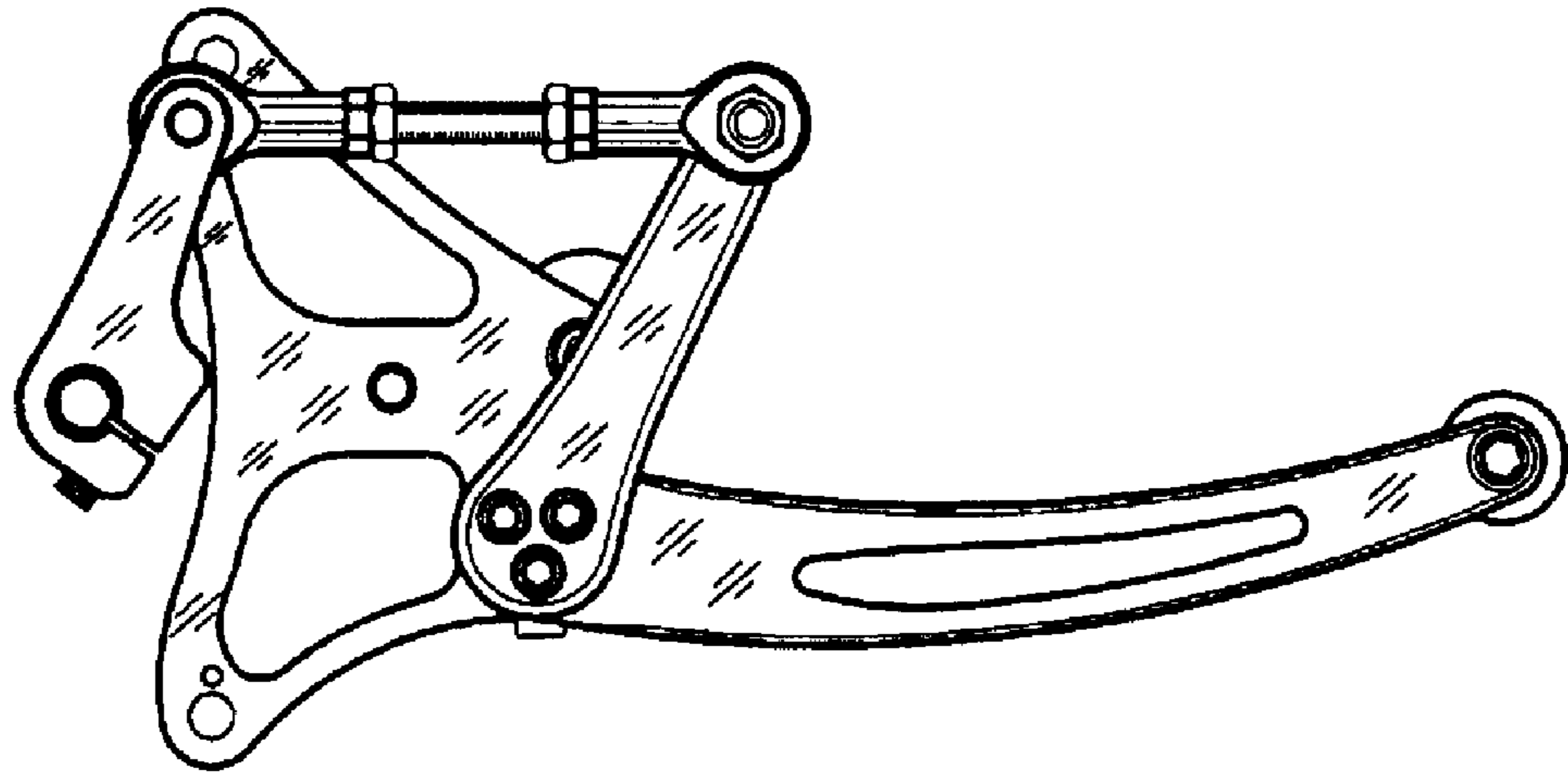

FIG 8

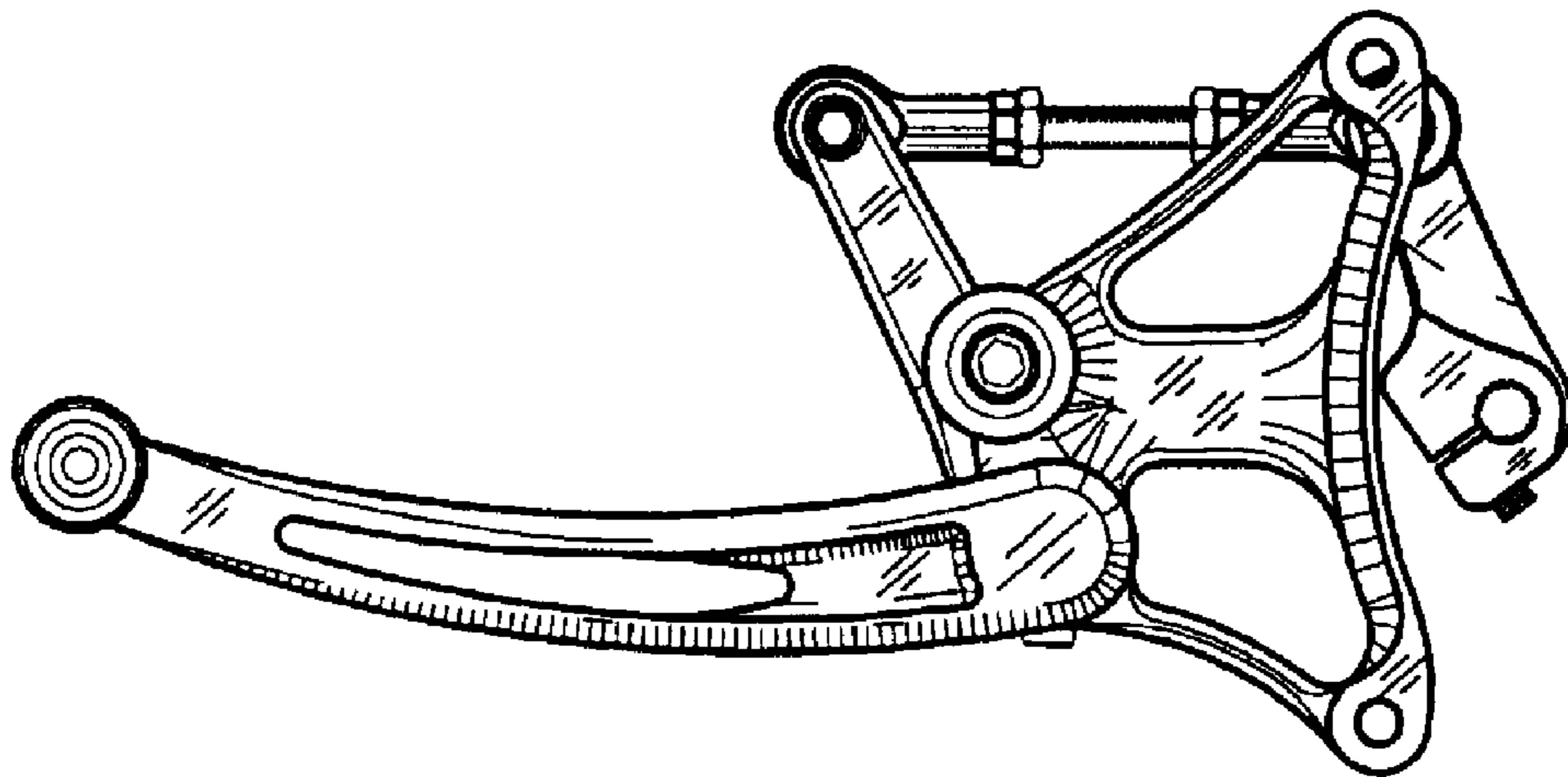

FIG 9

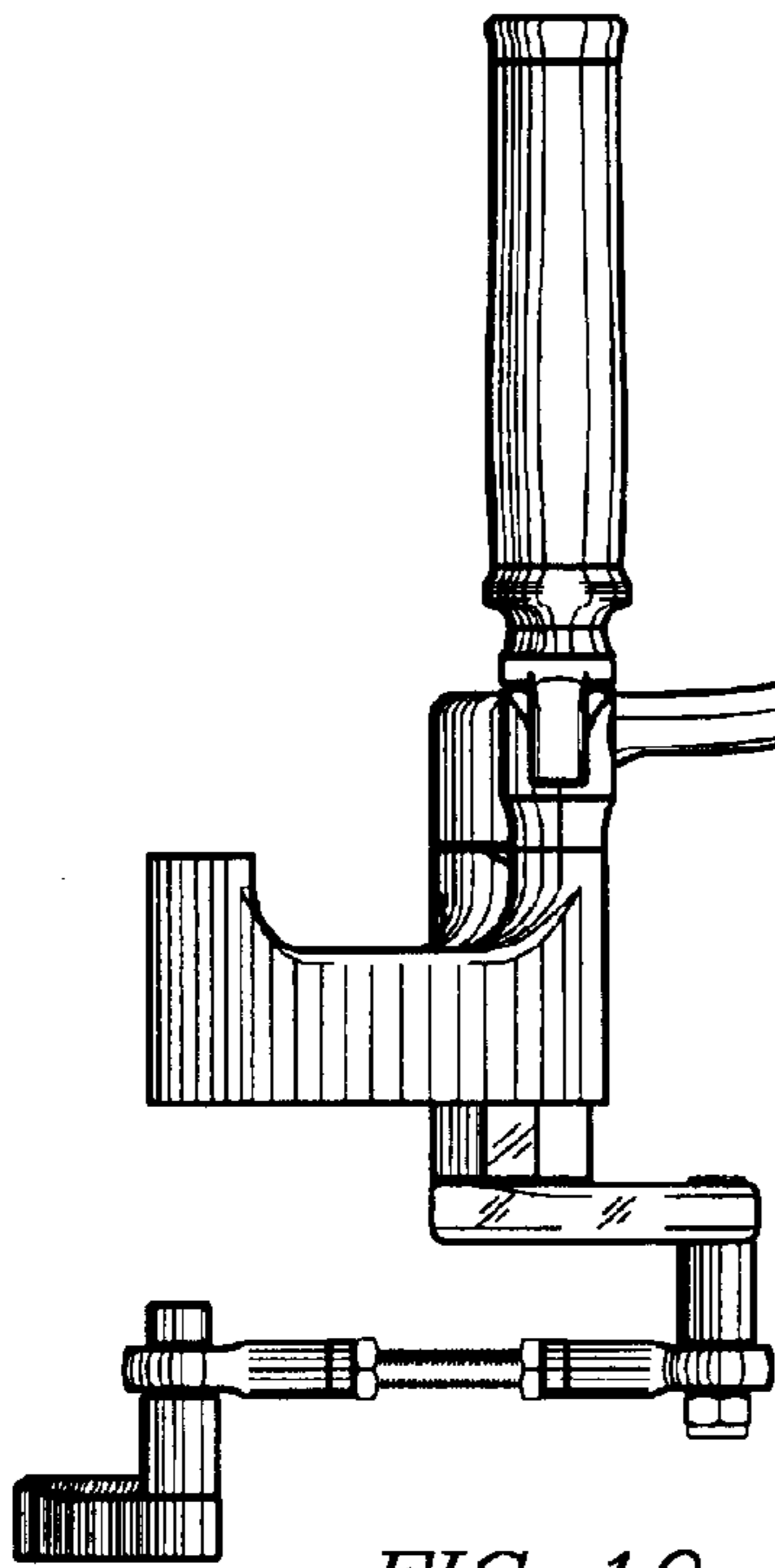

FIG 10

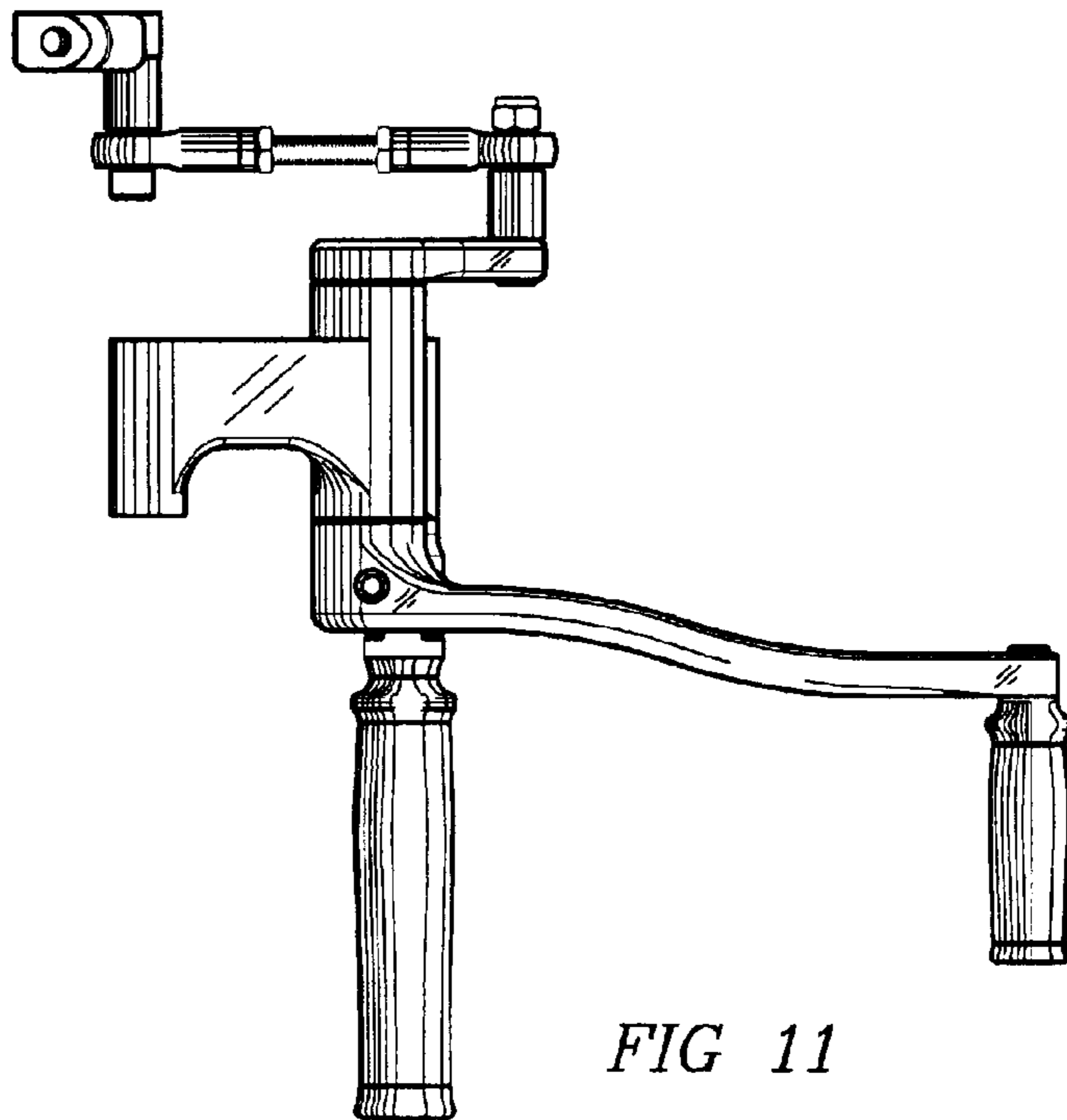
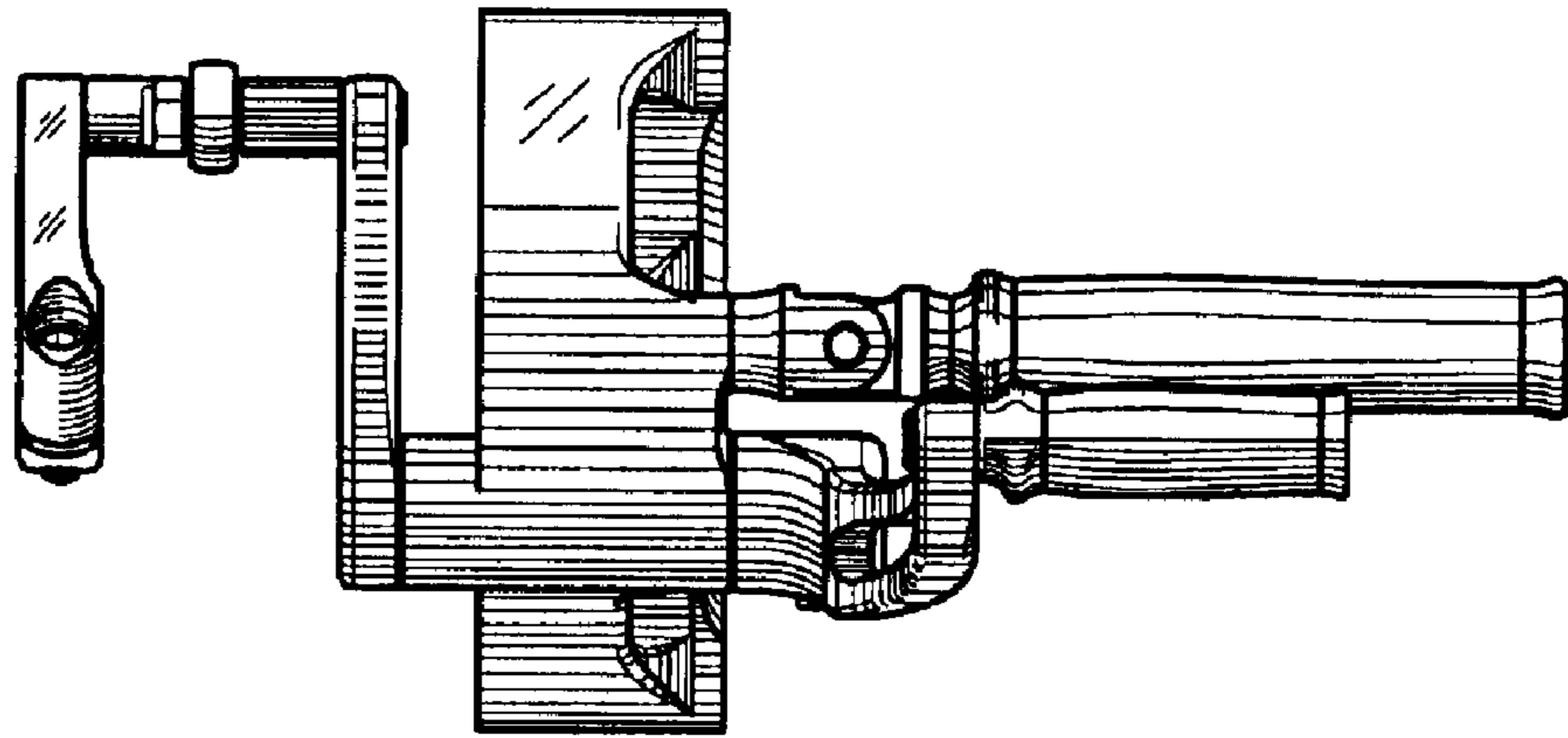
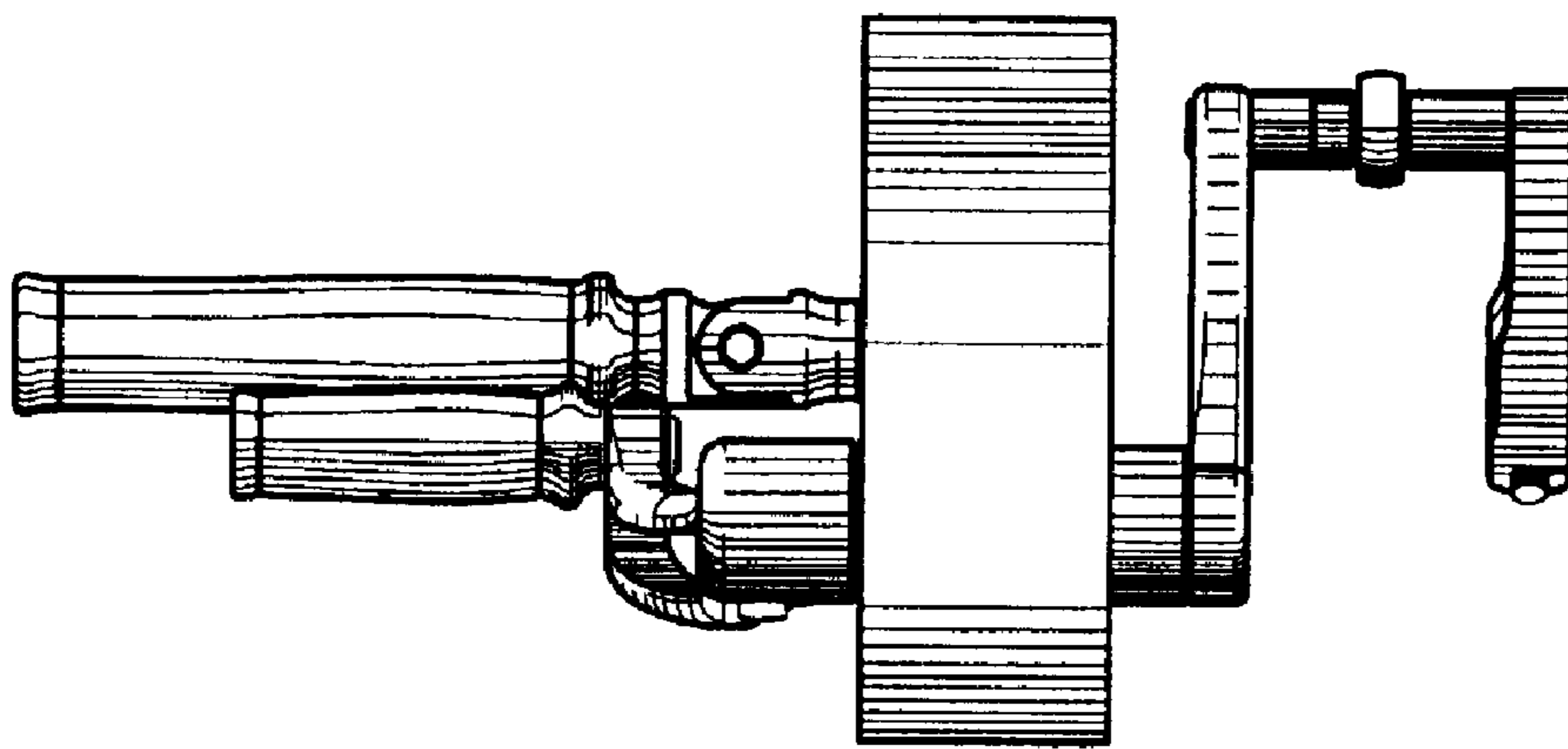

FIG 11



*FIG 12*



*FIG 13*