



US00D538826S

(12) **United States Design Patent**  
**Kienzle**

(10) **Patent No.:** **US D538,826 S**

(45) **Date of Patent:** **\*\* Mar. 20, 2007**

(54) **COMPRESSOR**

(75) **Inventor:** **Dominic Kienzle**, Renningen (DE)

(73) **Assignee:** **Bitzer Kuehlmaschinenbau GmbH**, Sindelfingen (DE)

(\*\*) **Term:** **14 Years**

(21) **Appl. No.:** **29/260,533**

(22) **Filed:** **May 26, 2006**

(30) **Foreign Application Priority Data**

Nov. 30, 2005 (EM) ..... 000441225

(51) **LOC (8) Cl.** ..... **15-02**

(52) **U.S. Cl.** ..... **D15/9**

(58) **Field of Classification Search** ..... D15/7-9;  
D23/232, 231; 417/359, 415-416, 410.1,  
417/321, 265, 405

See application file for complete search history.

(56) **References Cited**

**U.S. PATENT DOCUMENTS**

D245,501 S	*	8/1977	Fitch	.....	D15/7
D366,488 S	*	1/1996	Alfano et al.	.....	D15/9
D394,068 S		5/1998	Pollrich et al.		
D405,455 S	*	2/1999	Leu et al.	.....	D15/9
6,401,472 B2		6/2002	Pollrich et al.		
D465,791 S	*	11/2002	Moan	.....	D15/7
D466,523 S	*	12/2002	Saito	.....	D15/9

D467,254 S		12/2002	Ulrich		
D468,752 S	*	1/2003	Hopper	.....	D15/9
D479,245 S		9/2003	Leu		
D479,247 S	*	9/2003	Ullrich	.....	D15/9
D484,147 S	*	12/2003	Tai	.....	D15/9
D485,281 S	*	1/2004	Hsiao	.....	D15/9
D487,473 S		3/2004	Saito et al.		
D498,768 S	*	11/2004	Romandy et al.	.....	D15/9
D499,117 S	*	11/2004	Leasure et al.	.....	D15/9
D516,093 S	*	2/2006	Hsiao	.....	D15/9
D522,534 S	*	6/2006	Kawasaki	.....	D15/7

\* cited by examiner

*Primary Examiner*—Ralf Seifert

(74) *Attorney, Agent, or Firm*—Lipsitz & McAllister, LLC

(57) **CLAIM**

The ornamental design for a compressor, as shown and described.

**DESCRIPTION**

FIG. 1 is a front, top and left side perspective view of the compressor showing my new design;  
FIG. 2 is a left side elevational view of the design;  
FIG. 3 is a top plan view of the design;  
FIG. 4 is a front elevational view of the design;  
FIG. 5 is a rear elevational view of the design;  
FIG. 6 is a right side elevational view of the design; and,  
FIG. 7 is a bottom plan view of the design.

**1 Claim, 7 Drawing Sheets**

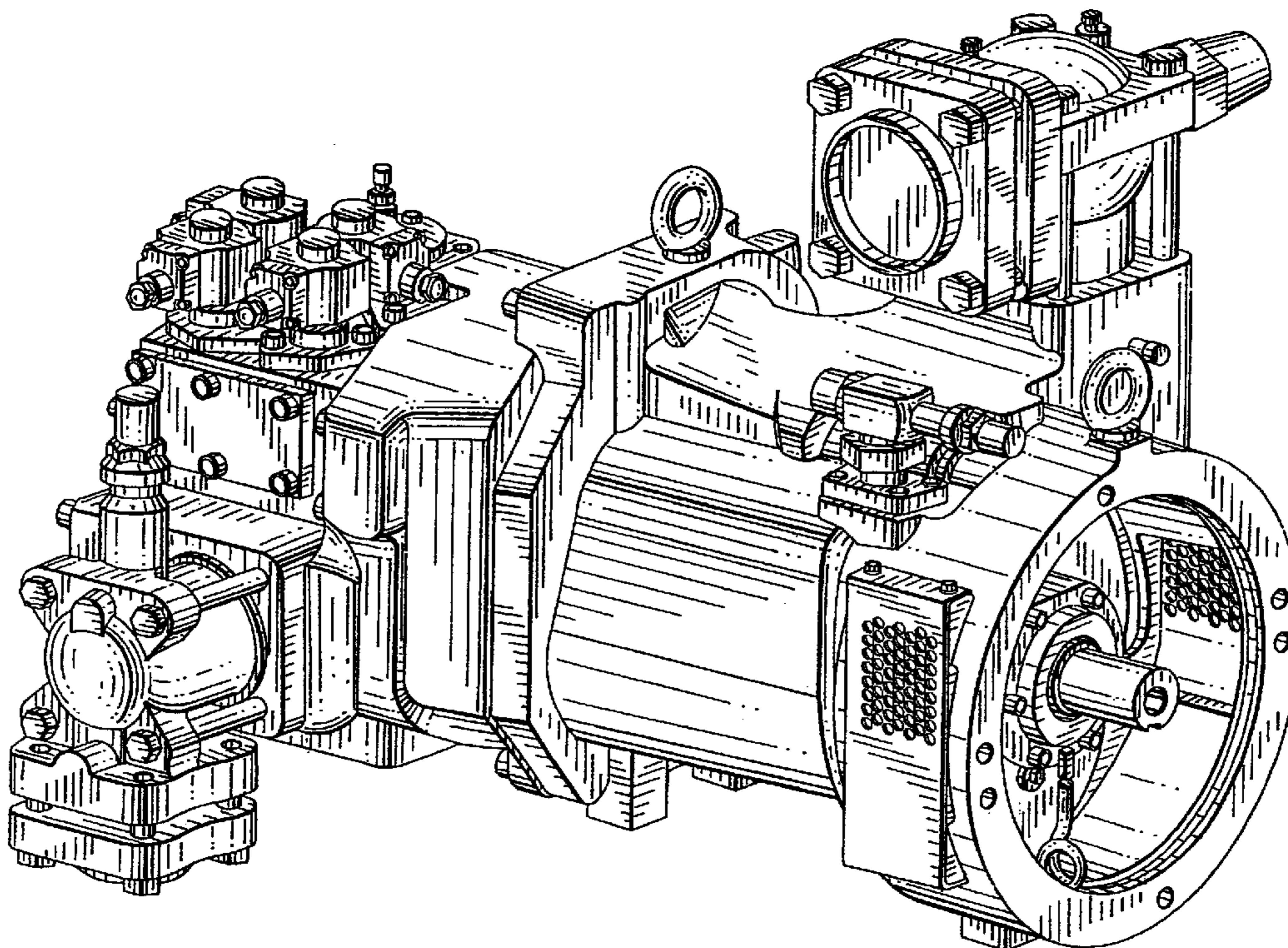

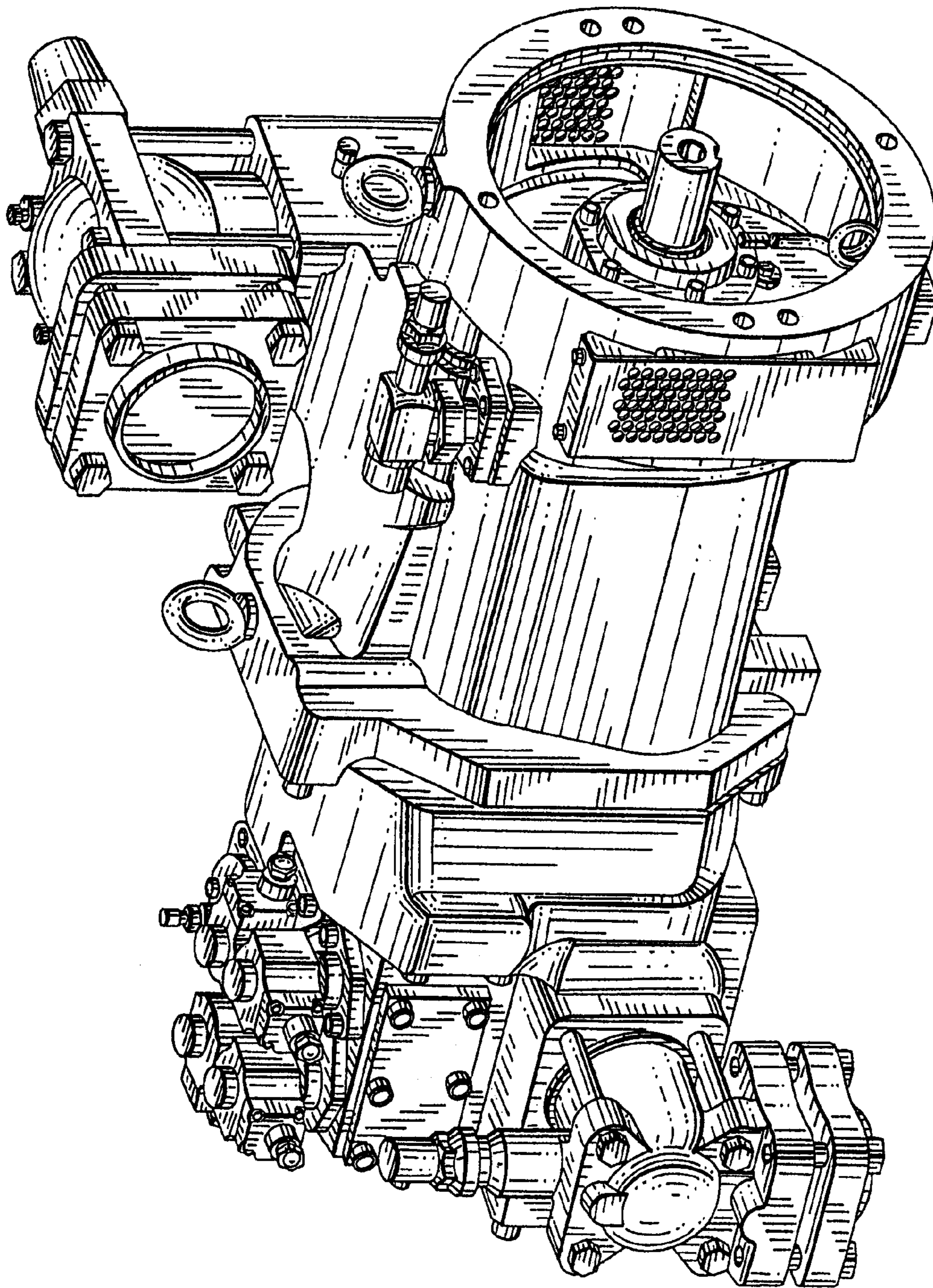

FIG. 1

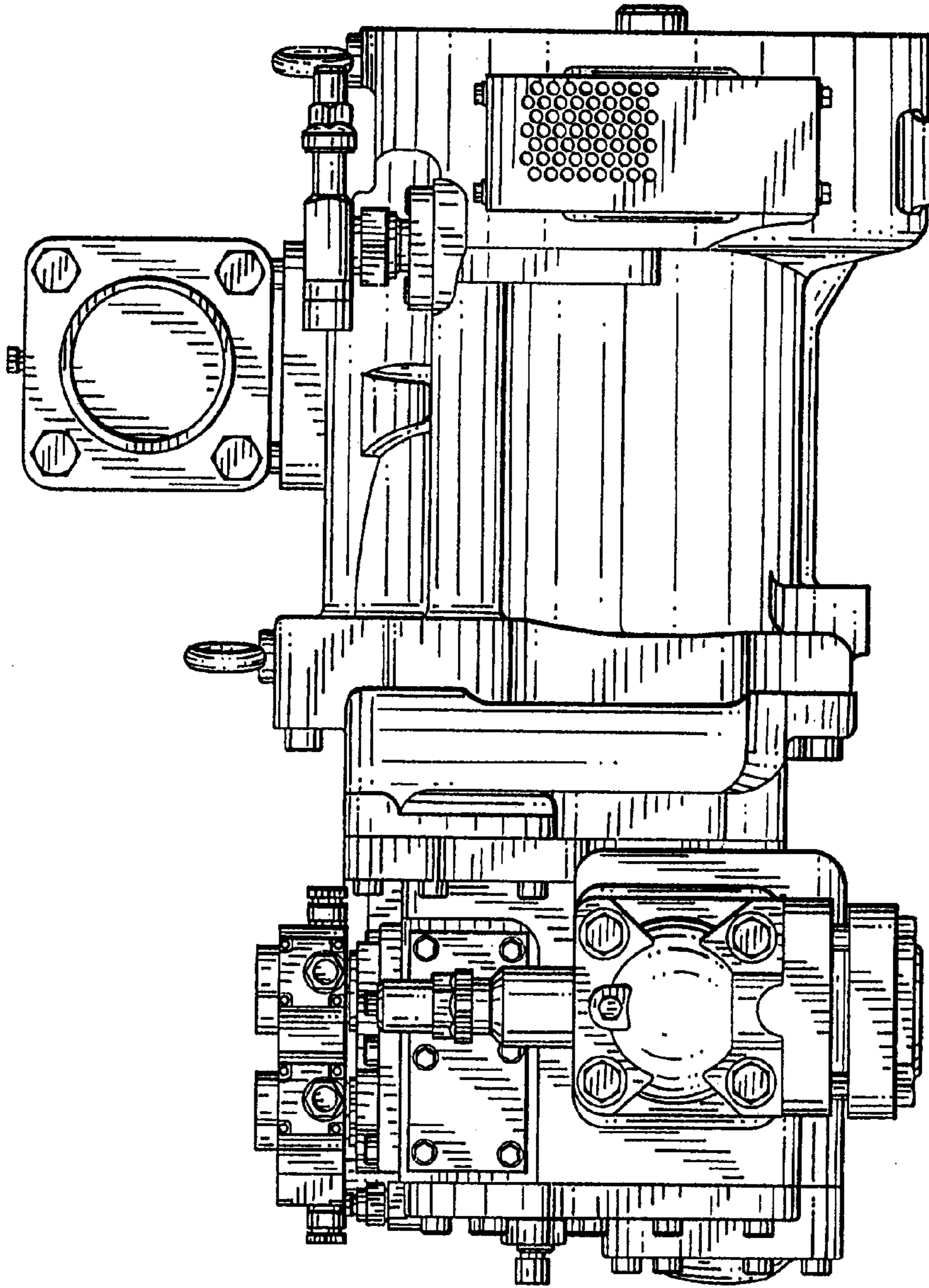

FIG.2

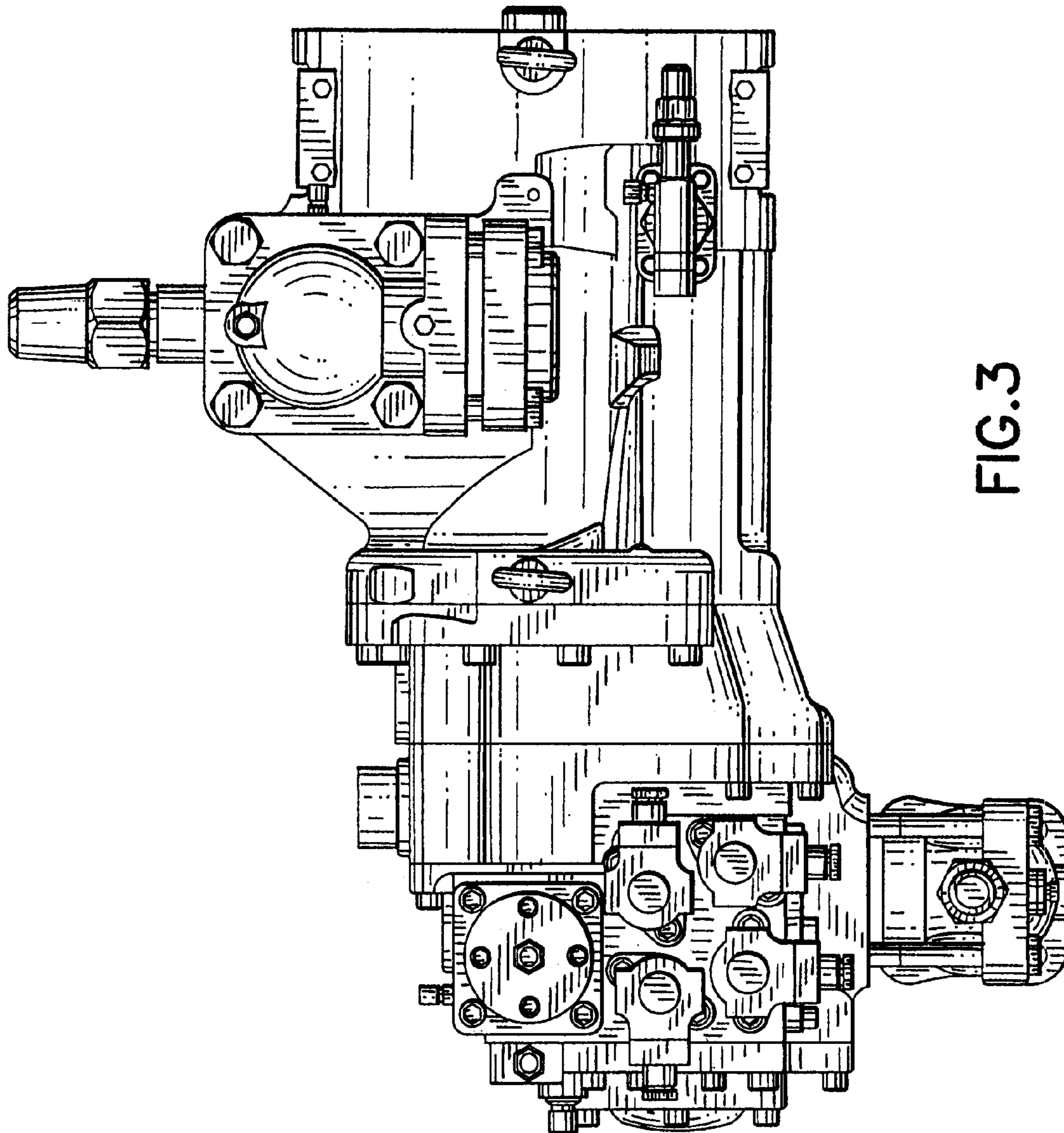

FIG. 3

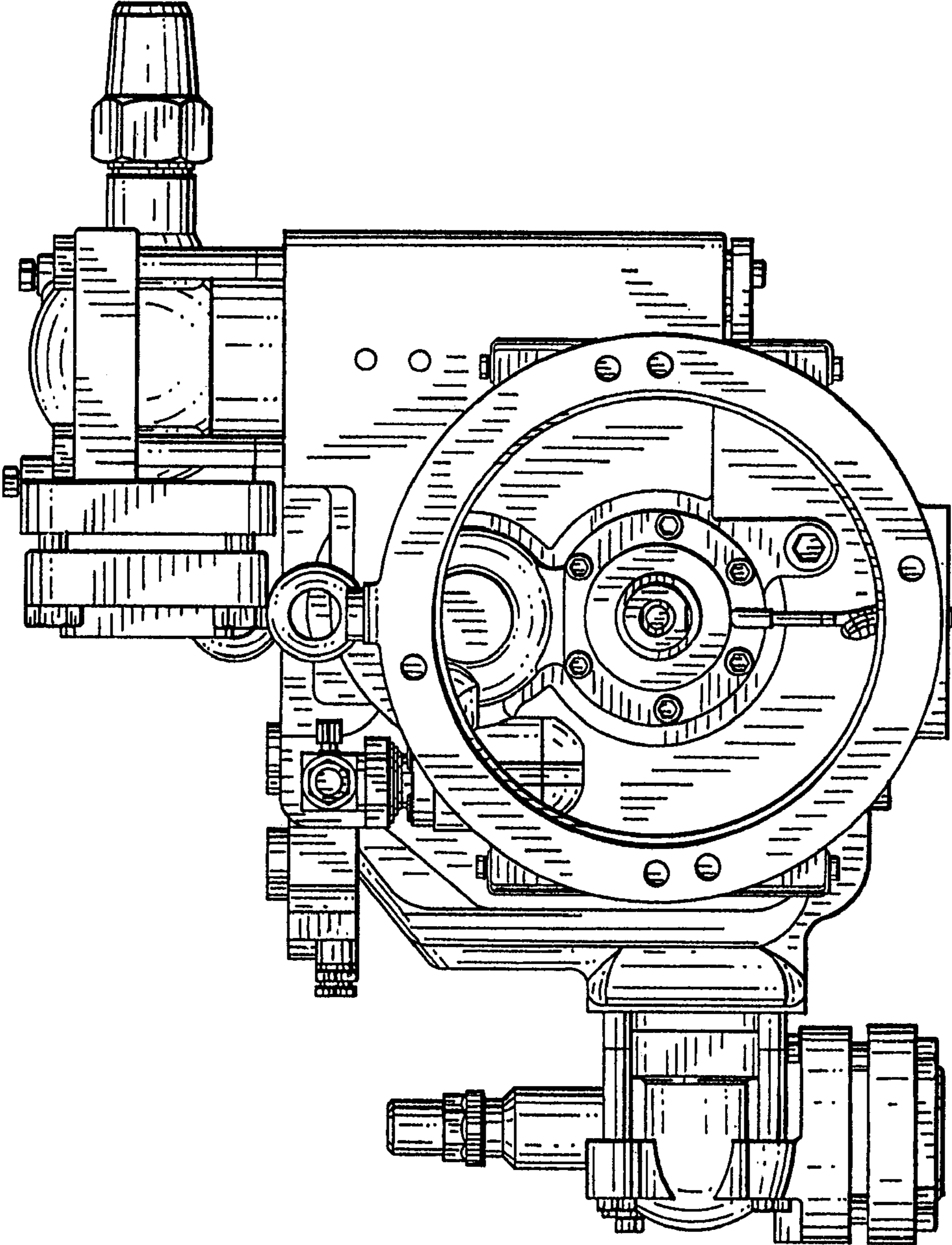

FIG. 4

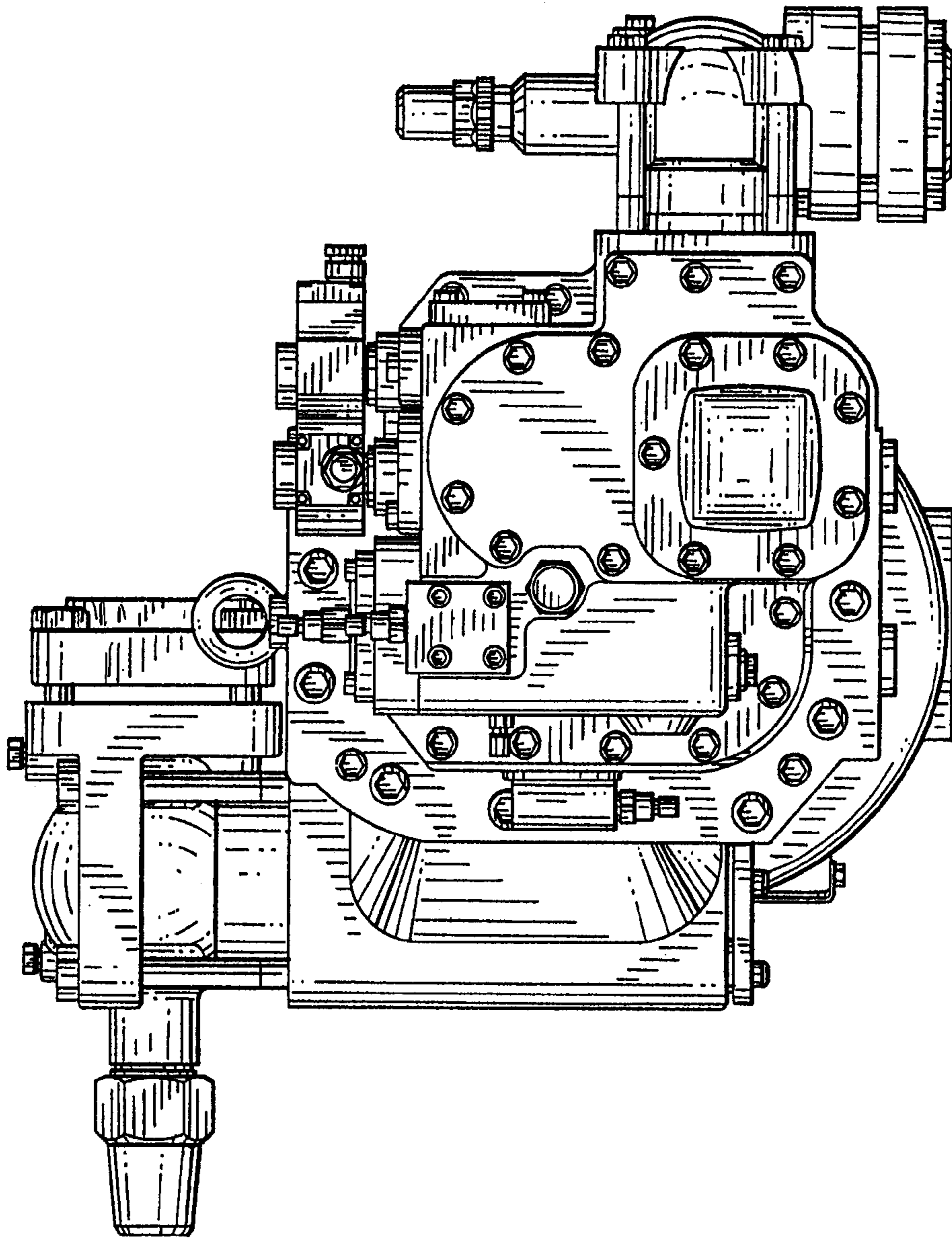

FIG. 5

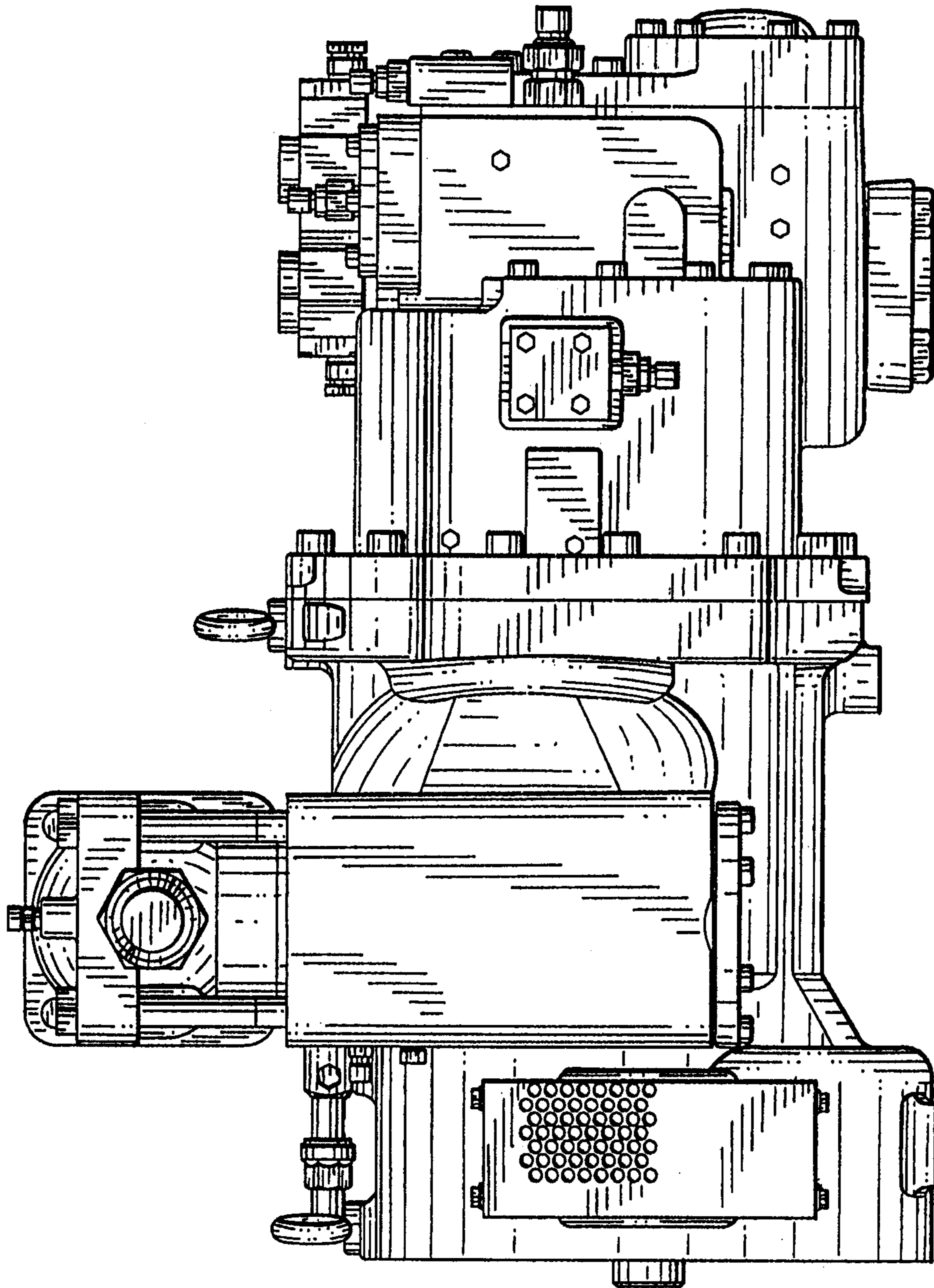

FIG. 6

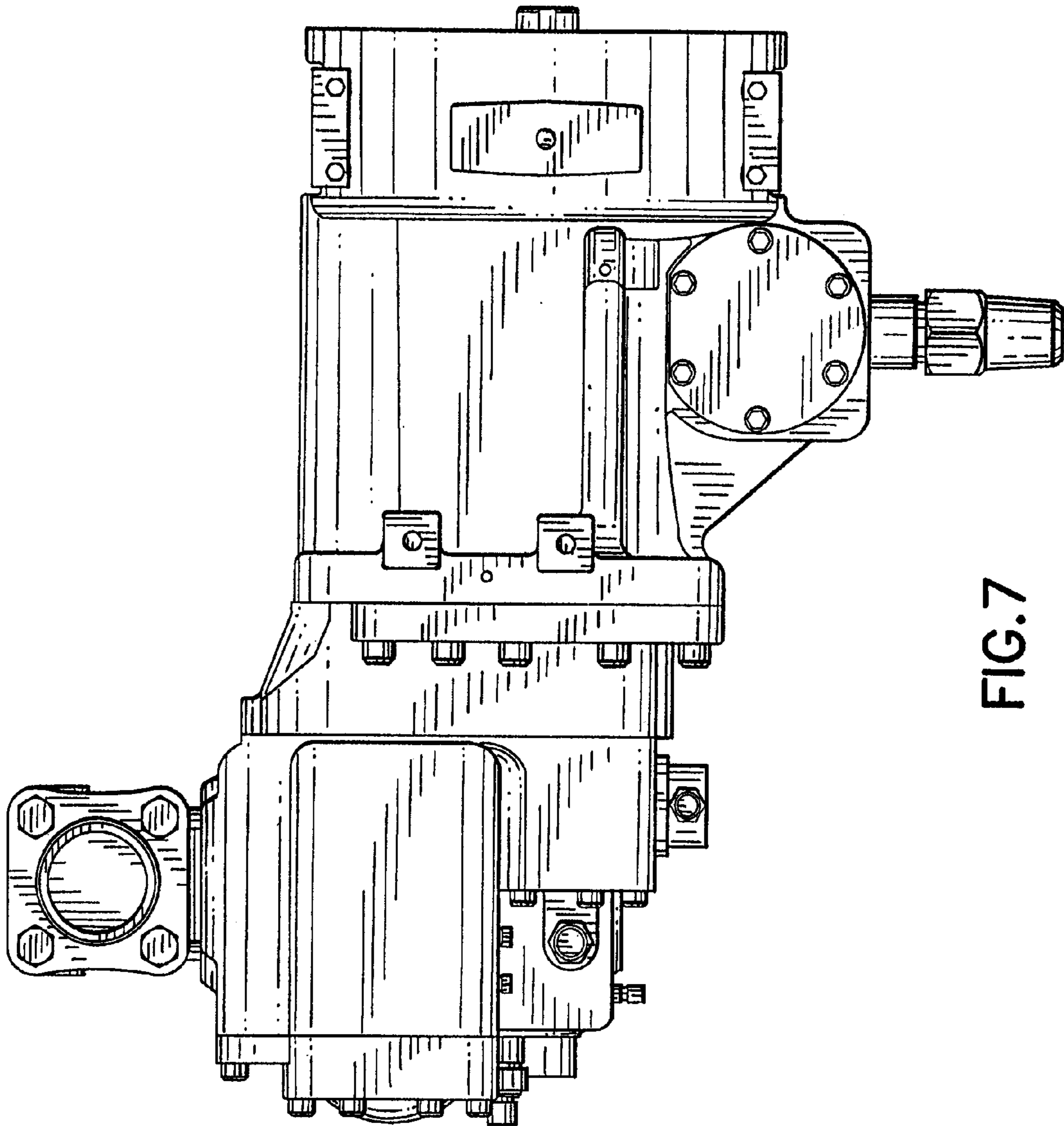

FIG. 7