



US00D538806S

(12) **United States Design Patent** (10) **Patent No.:** **US D538,806 S**
Brod et al. (45) **Date of Patent:** **** Mar. 20, 2007**

(54) **RADIO FREQUENCY IDENTIFICATION
DEVICE ENCLOSURE**

(75) Inventors: **Joshua Brod**, Highland Village, TX
(US); **Molly Condon**, Minneapolis, MN
(US); **Gerald Crouse**, Plano, TX (US);
Richard Schendel, Minneapolis, MN
(US); **Patrick Shewmake**, Plano, TX
(US); **Lester Williams**, Plano, TX
(US); **Dean Willey**, Minneapolis, MN
(US)

(73) Assignee: **Target Brands, Inc.**, Minneapolis, MN
(US)

(**) Term: **14 Years**

(21) Appl. No.: **29/240,153**

(22) Filed: **Oct. 7, 2005**

(51) **LOC (8) Cl.** **14-02**

(52) **U.S. Cl.** **D14/385**

(58) **Field of Classification Search** D14/383-385;
D10/106; 235/451, 382, 382.5; 312/223.1-223.3;
340/572.4, 572.7; 700/214, 218, 226

See application file for complete search history.

(56) **References Cited**

U.S. PATENT DOCUMENTS

3,818,472	A	*	6/1974	Mauk et al.	340/572.4
D297,221	S	*	8/1988	Podhrasky	D10/106
D307,400	S	*	4/1990	Armstrong et al.	D10/106
5,712,789	A	*	1/1998	Radican	700/226
5,953,234	A	*	9/1999	Singer et al.	700/214
6,253,118	B1	*	6/2001	Koyama	700/218
6,332,098	B2	*	12/2001	Ross et al.	700/226
D490,811	S	*	6/2004	Taniguchi	D14/385
2003/0141366	A1	*	7/2003	Hartmann	235/451
2003/0168949	A1	*	9/2003	Hales	312/223.1
2005/0162276	A1	*	7/2005	Balch et al.	340/572.7
2005/0168385	A1		8/2005	Baker		

OTHER PUBLICATIONS

<http://www.sensormatic.com/RFID/default.asp>, "RFID Solutions," 2003, 2 pgs.

http://www.ocr.ca/product_info.asp?product_ID=670, "DC400 WLAN RFID Portable Reader," 2005, 2 pgs.

<http://www.genesta.com/content.asp?TId=6&STId=31&AId=20>, "RFID Portals," 2005, 1 pg.

<http://www.sensormatic.com/RFID/default.asp>, "RFID Solutions," 2003, 2 pgs.

http://www.ocr.ca/product.info.asp?product_ID=670, "DC400 WLAN RFID Portable Reader" 2005, 2 pgs.

[http://www/genesta.com/content.asp?TId=6&STId=31&AId=20](http://www.genesta.com/content.asp?TId=6&STId=31&AId=20), "RFID Portals," 2005, 1 pg.

<http://www.symbol.com/assets/files/Dc400ds.pdf> "DC 400 Turn-Key High-Performance for Dock Door Visibility", Sep. 2004, 2 pgs.

<http://www.venturesearch.com/PortalSpecSheetIIIRes.pdf>, "RFID Reader Portals -RFID Solution," 1 pg. "ADMITTED PRIOR ART".

* cited by examiner

Primary Examiner—Freda S. Nunn

(74) *Attorney, Agent, or Firm*—Dicke, Billig & Czaja, PLLC

(57) **CLAIM**

The ornamental design for a radio frequency identification device enclosure, as shown and described.

DESCRIPTION

FIG. 1 is an isometric view of a radio frequency identification device enclosure according to an embodiment of the invention with elements in dashed lines forming no part of the claimed design.

FIG. 2 is a front view of a radio frequency identification device enclosure according to an embodiment of the invention with elements in dashed lines forming no part of the claimed design.

FIG. 3 is a back view of a radio frequency identification device enclosure according to an embodiment of the invention with elements in dashed lines forming no part of the claimed design.

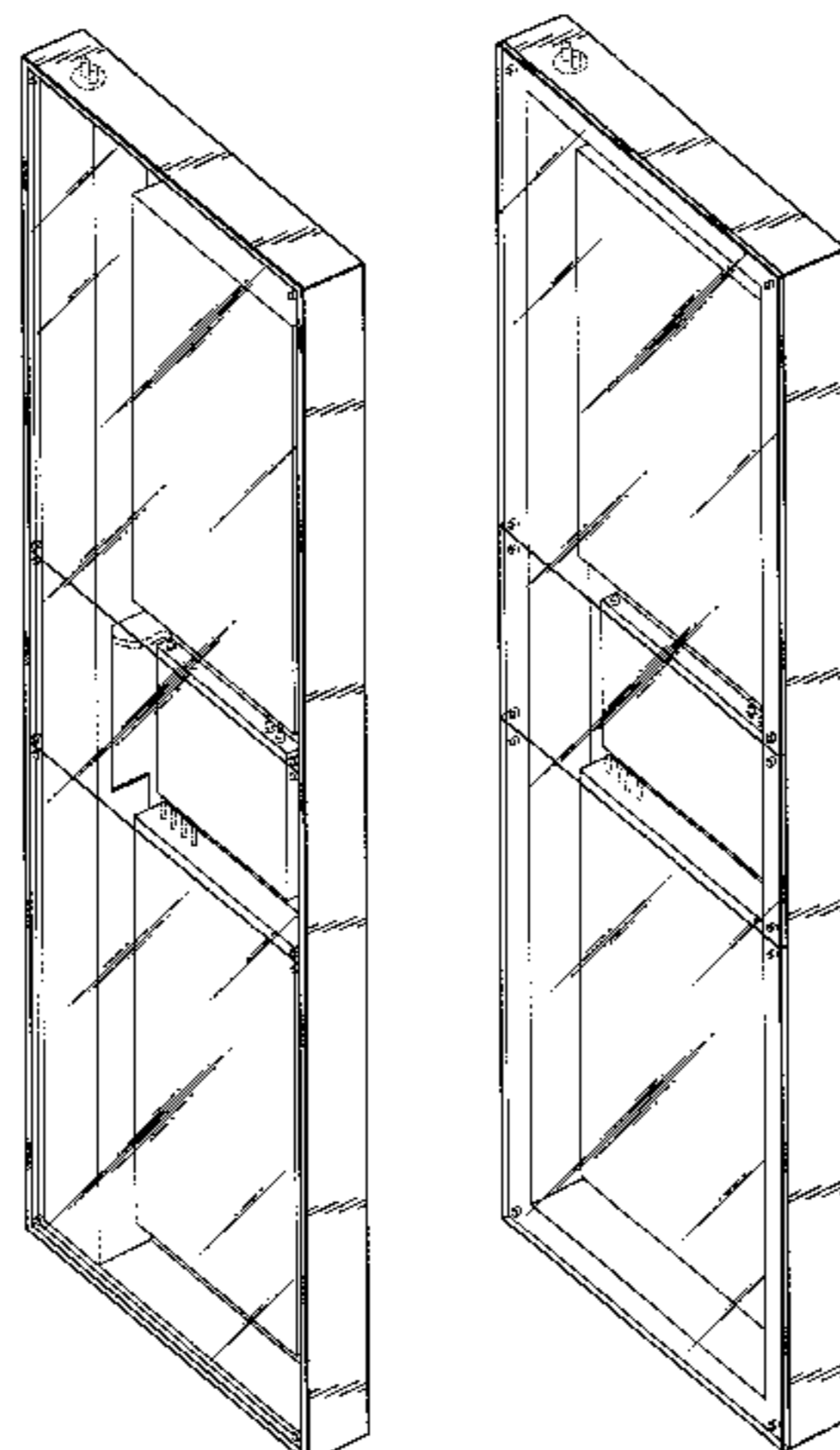

FIG. 4 is a right side view of a radio frequency identification device enclosure according to an embodiment of the invention with elements in dashed lines forming no part of the claimed design. A left side view of a radio frequency identification device enclosure is an identical mirror image of FIG. 4 and is omitted.

FIG. 5 is a top view of a radio frequency identification device enclosure according to an embodiment of the invention with elements in dashed lines forming no part of the claimed design.

FIG. 6 is a bottom view of a radio frequency identification device enclosure according to an embodiment of the invention with elements in dashed lines forming no part of the claimed design.

FIG. 7 is an isometric view of a radio frequency identification device enclosure in a floor mounted environment according to an embodiment of the invention with elements in dashed lines forming no part of the claimed design.

FIG. 8 is an isometric view of two radio frequency identification device enclosures in a back-to-back, floor mounted environment according to an embodiment of the invention with elements in dashed lines forming no part of the claimed design.

FIG. 9 is an isometric view of a radio frequency identification device enclosure in a wall mounted environment according to an embodiment of the invention with elements in dashed lines forming no part of the claimed design.

FIG. 10 is an isometric view of a radio frequency identification device enclosure in a recessed, wall mounted environment according to an embodiment of the invention with elements in dashed lines forming no part of the claimed design.

FIG. 11 is an isometric view of a second embodiment of a radio frequency identification device enclosure according to an embodiment of the invention with elements in dashed lines forming no part of the claimed design.

FIG. 12 is a front view of a radio frequency identification device enclosure according to an embodiment of the invention with elements in dashed lines forming no part of the claimed design.

FIG. 13 is a back view of a radio frequency identification device enclosure according to an embodiment of the invention with elements in dashed lines forming no part of the claimed design.

FIG. 14 is a right side view of a radio frequency identification device enclosure according to an embodiment of the invention with elements in dashed lines forming no part of the claimed design. A left side view of a radio frequency identification device enclosure is an identical mirror image of FIG. 14 and is omitted.

FIG. 15 is a top view of a radio frequency identification device enclosure according to an embodiment of the invention with elements in dashed lines forming no part of the claimed design.

FIG. 16 is a bottom view of a radio frequency identification device enclosure according to an embodiment of the invention with elements in dashed lines forming no part of the claimed design.

FIG. 17 is an isometric view of a radio frequency identification device enclosure in a floor mounted environment according to an embodiment of the invention with elements in dashed lines forming no part of the claimed design.

FIG. 18 is an isometric view of two radio frequency identification device enclosures in a back-to-back, floor mounted environment according to an embodiment of the invention with elements in dashed lines forming no part of the claimed design.

FIG. 19 is an isometric view of a radio frequency identification device enclosure in a wall mounted environment according to an embodiment of the invention with elements in dashed lines forming no part of the claimed design; and,

FIG. 20 is an isometric view of a radio frequency identification device enclosure in a recessed, wall mounted environment according to an embodiment of the invention with elements in dashed lines forming no part of the claimed design.

1 Claim, 16 Drawing Sheets

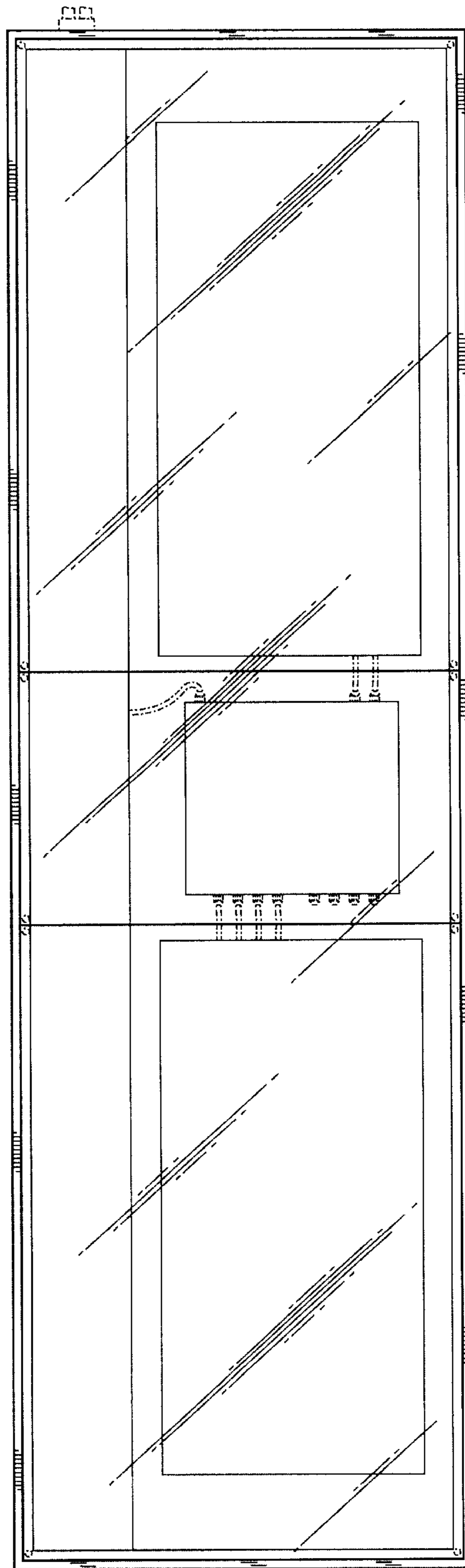

Fig. 2

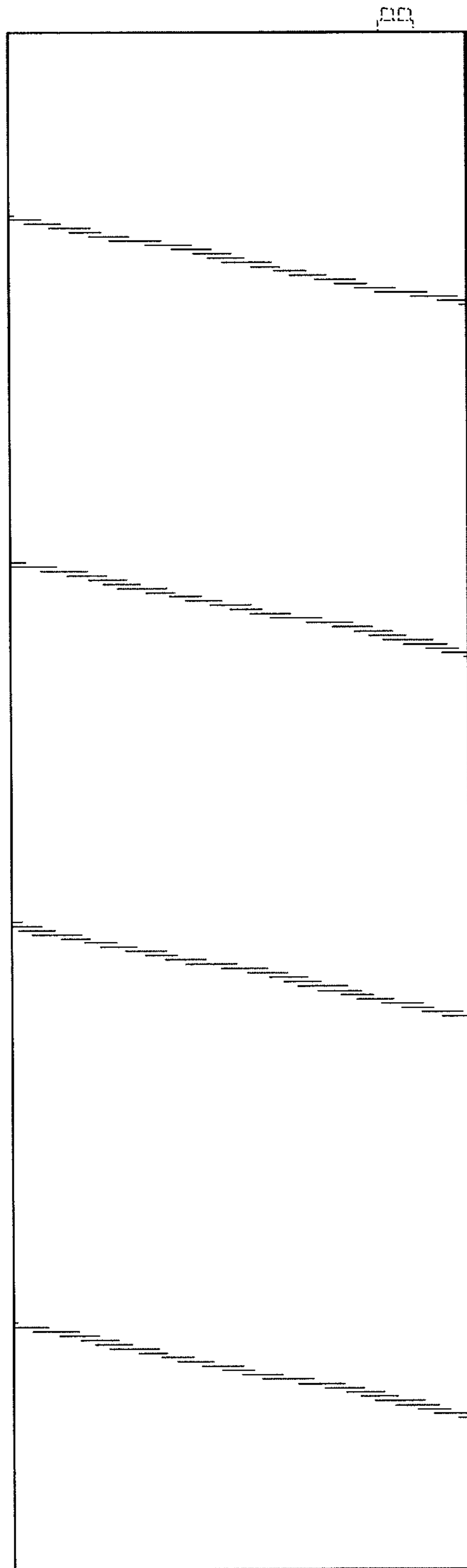

Fig. 3

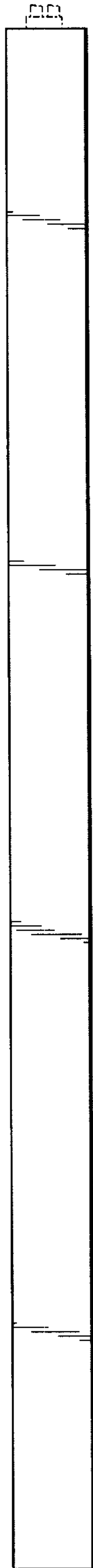

Fig. 4



Fig. 5



Fig. 6

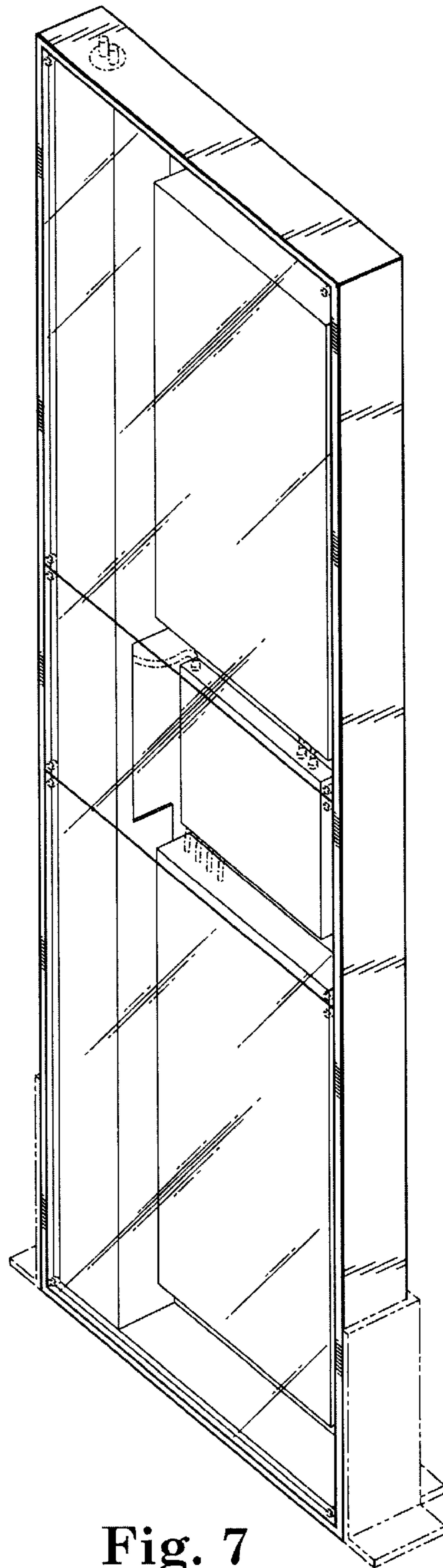

Fig. 7

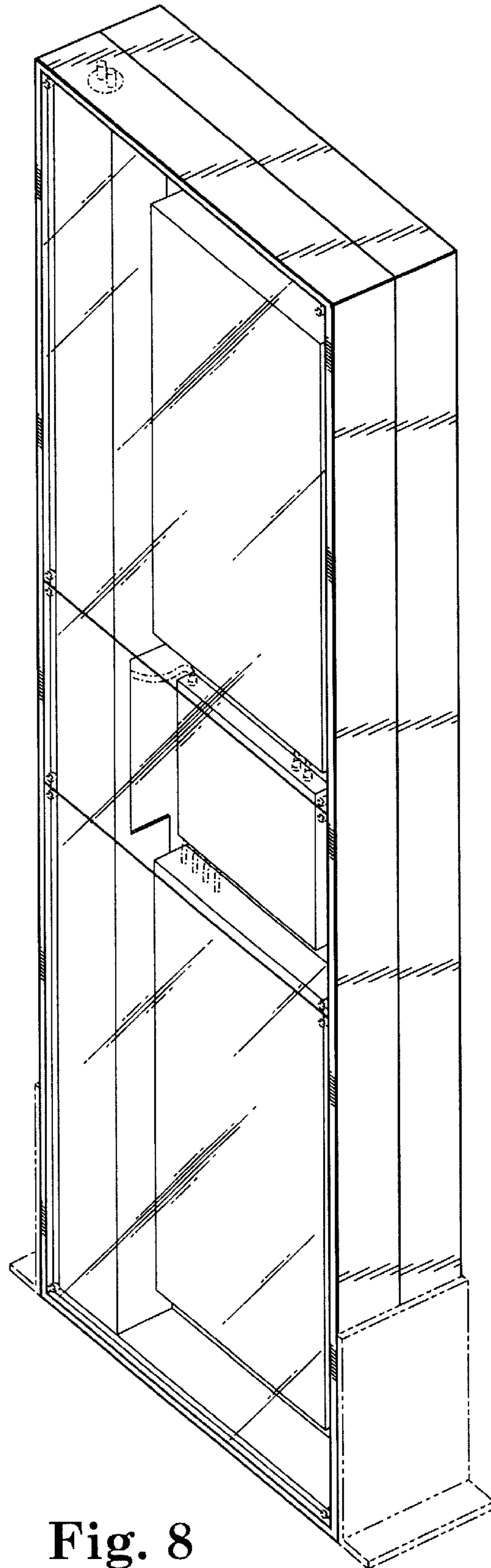

Fig. 8

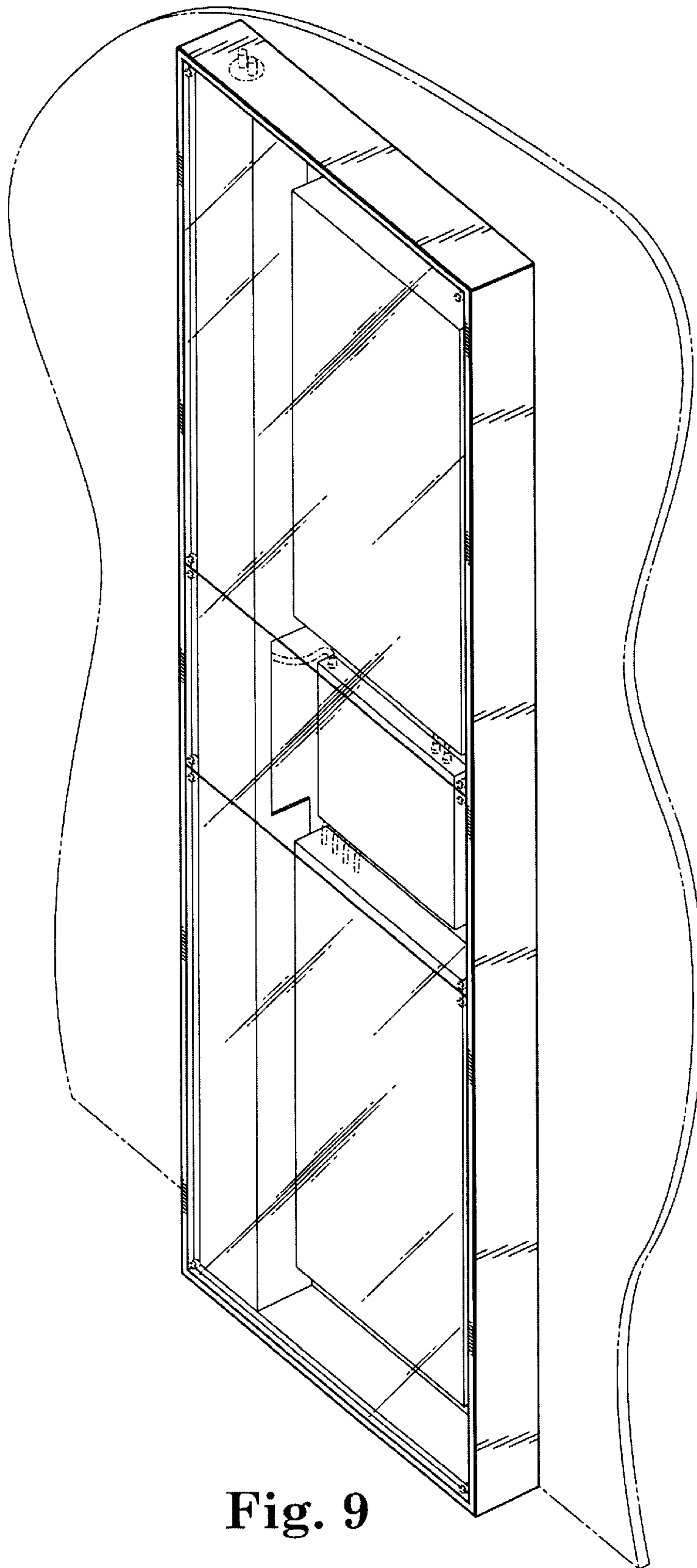

Fig. 9

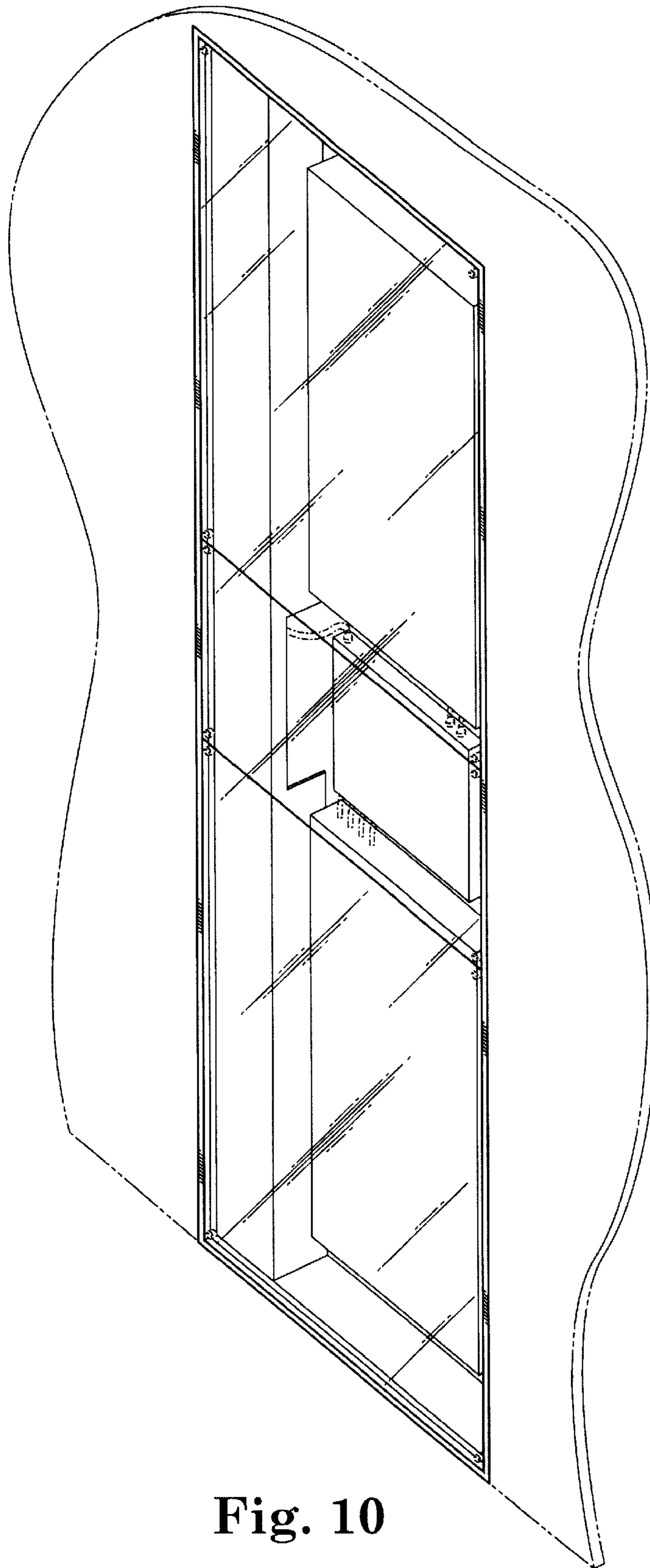

Fig. 10

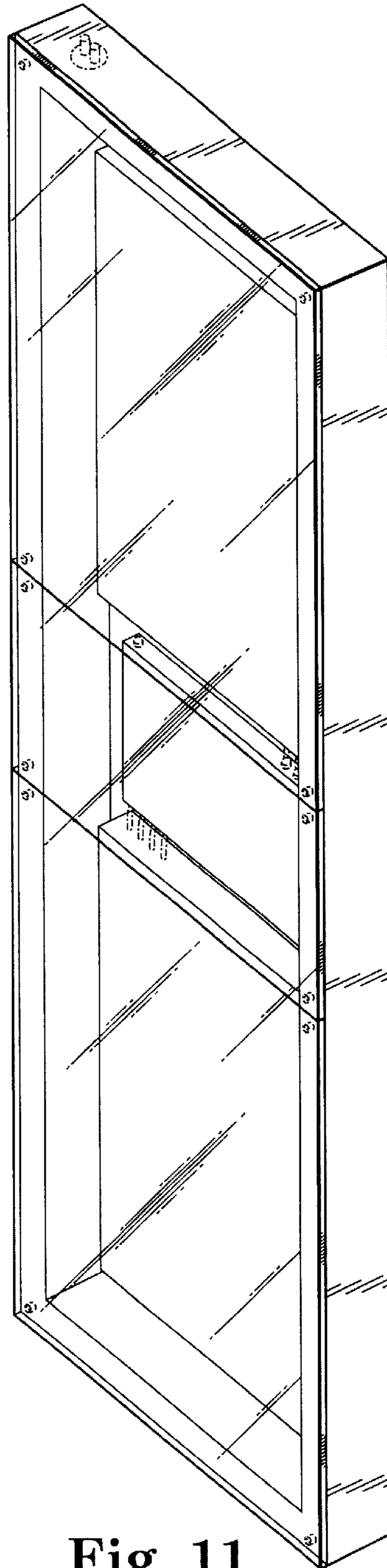

Fig. 11

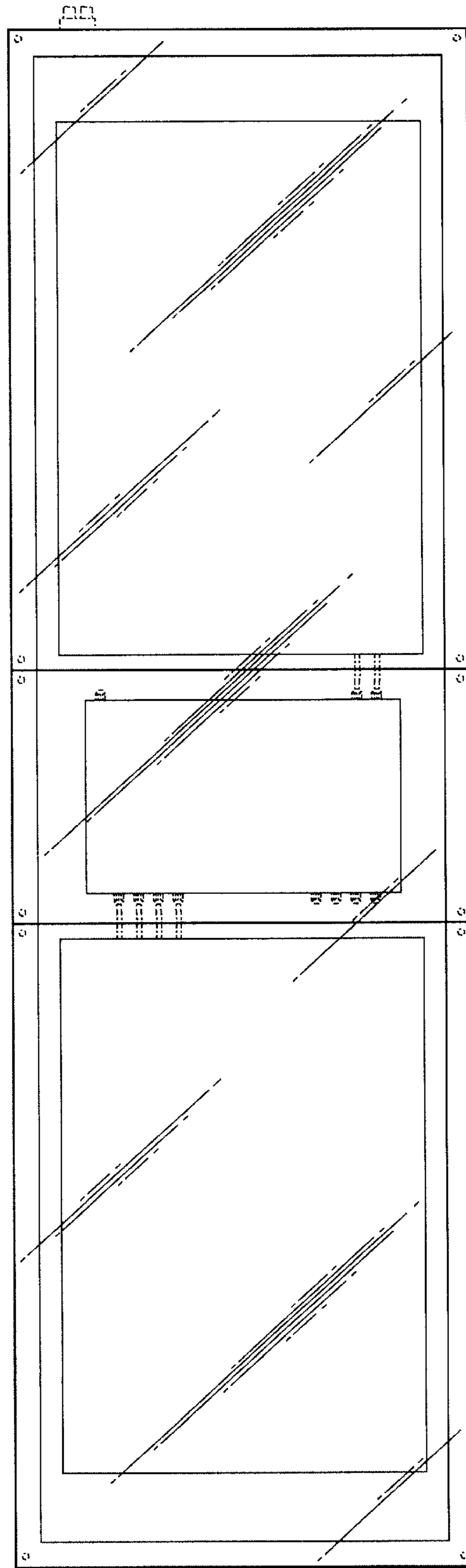

Fig. 12

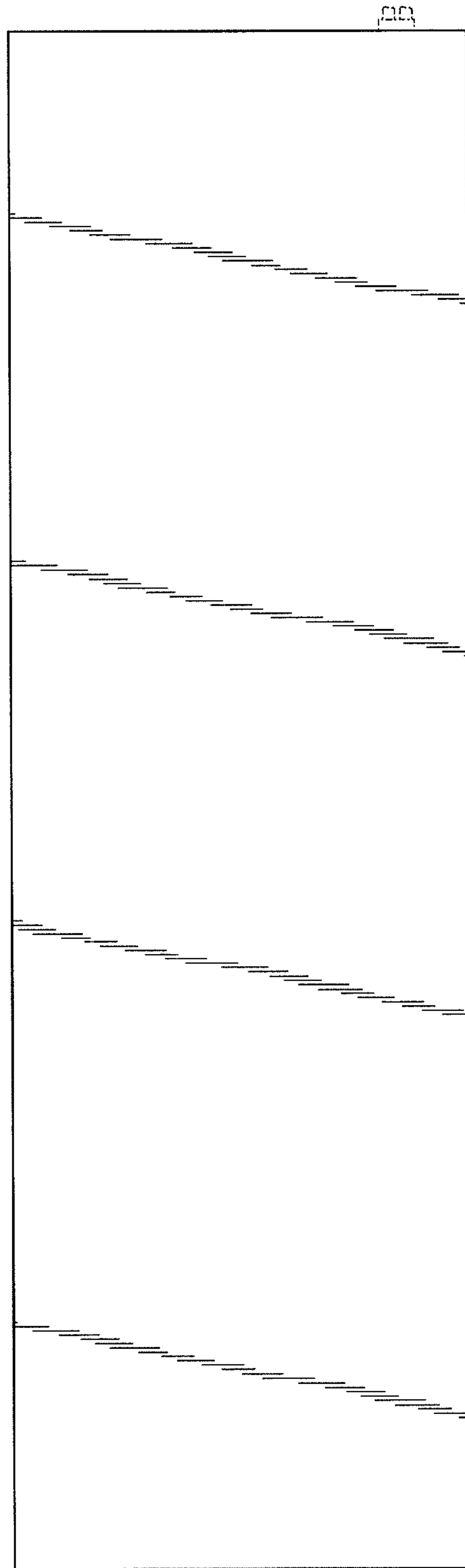

Fig. 13

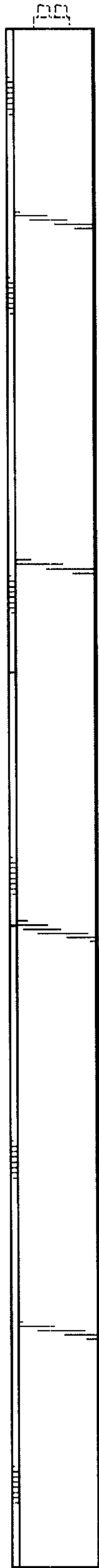

Fig. 14

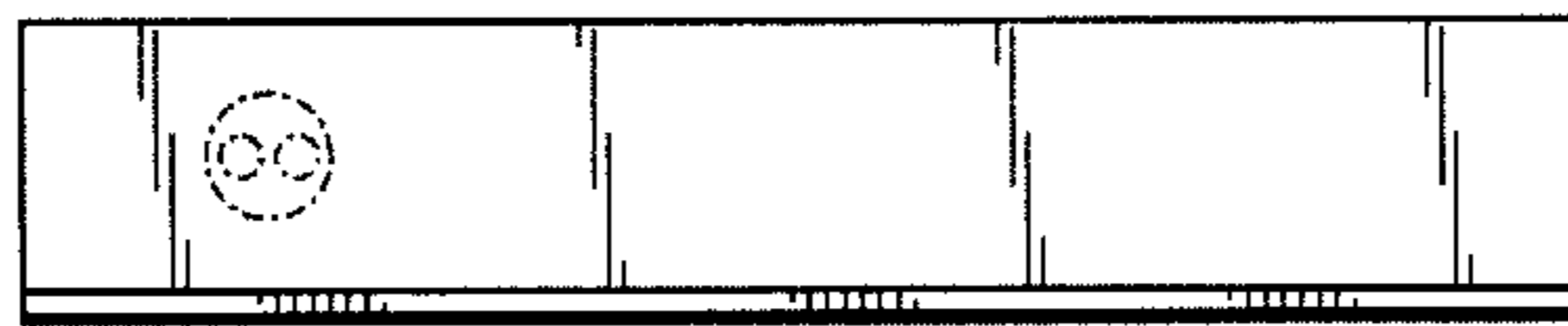

Fig. 15

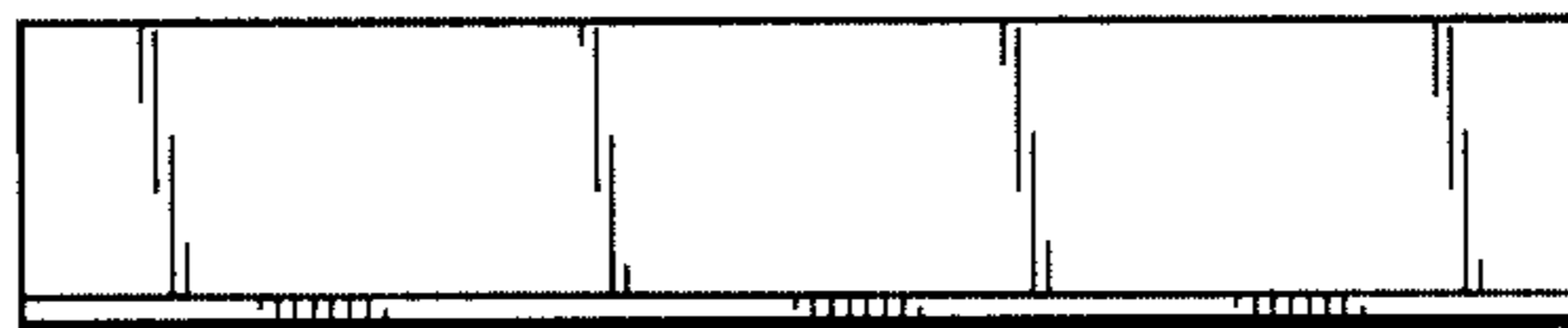

Fig. 16

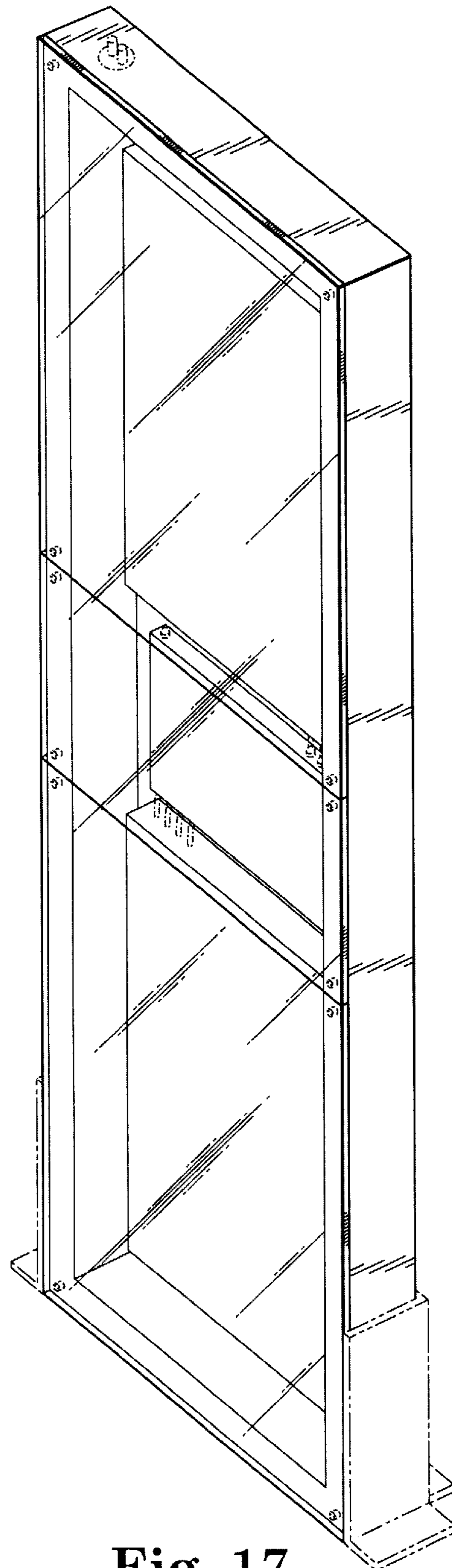

Fig. 17

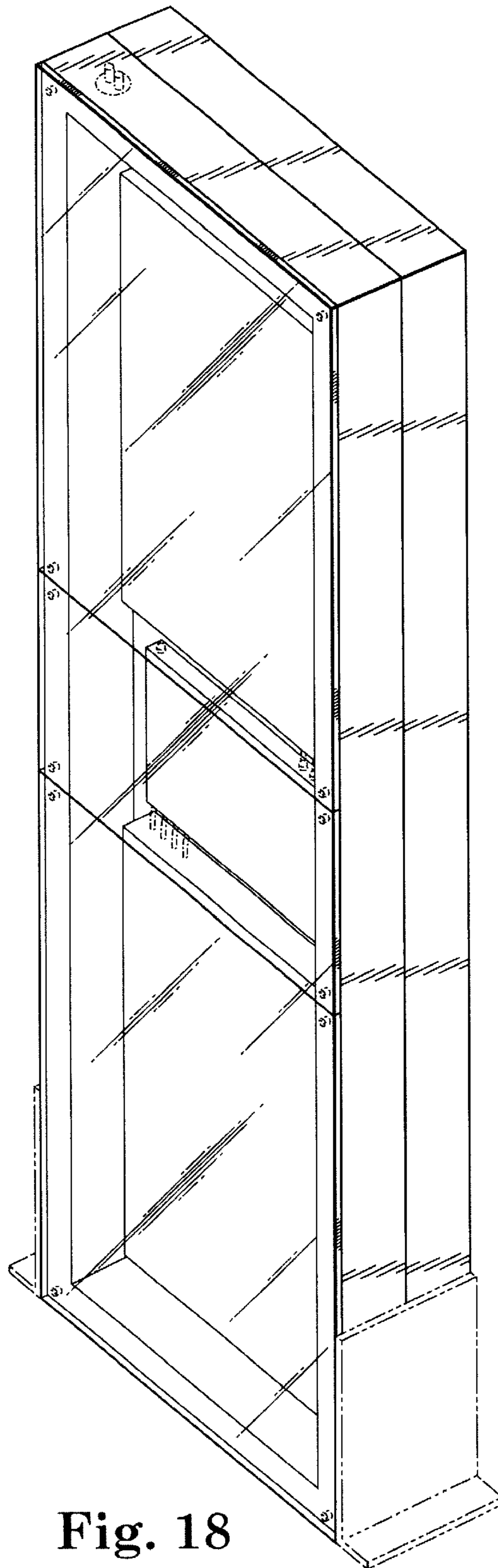

Fig. 18

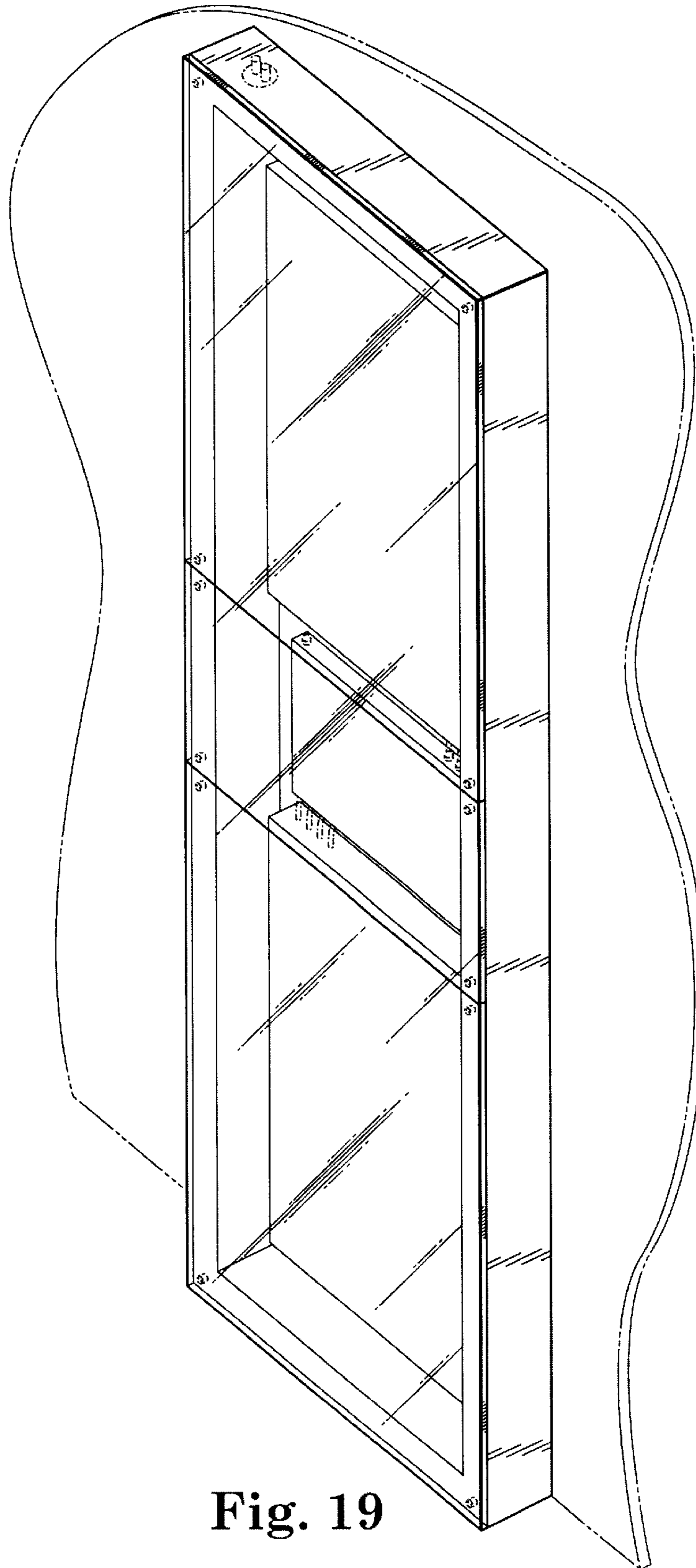

Fig. 19

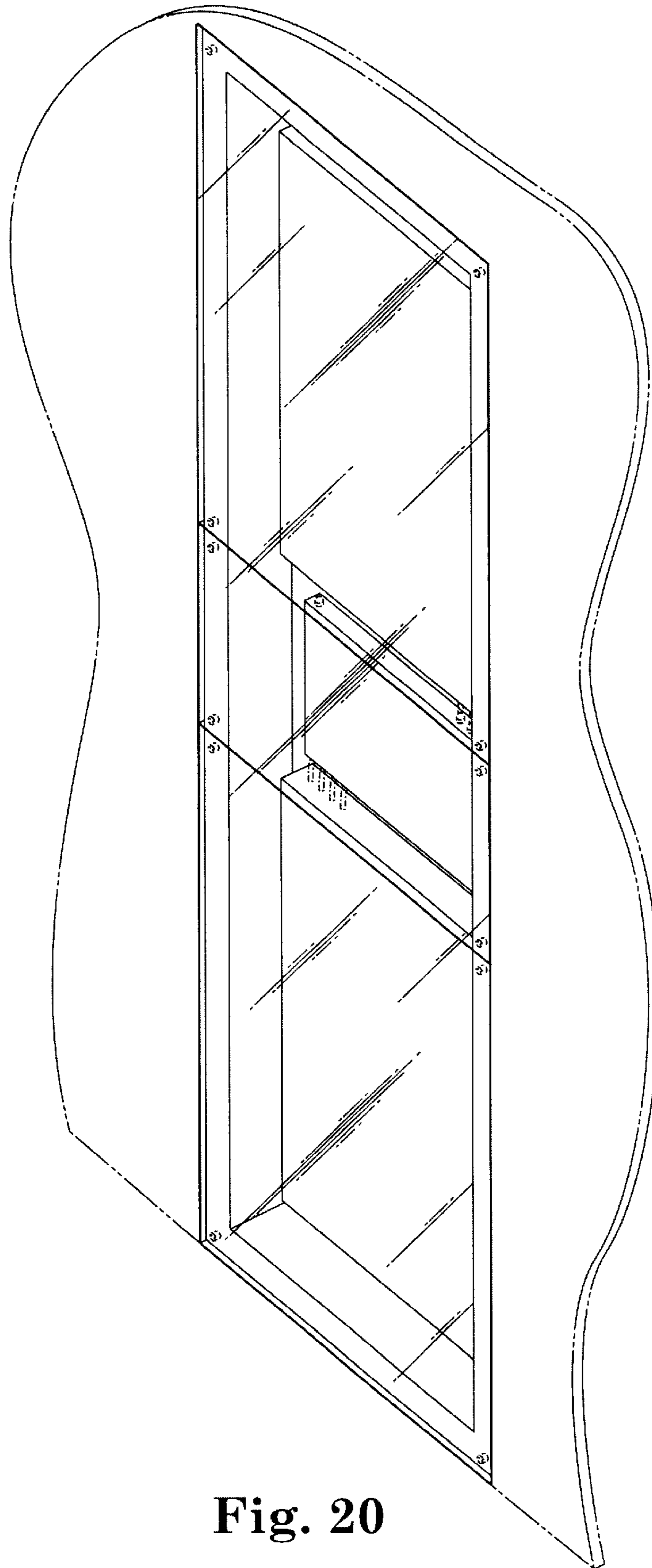

Fig. 20