



US00D538452S

(12) **United States Design Patent**  
**Pfeiffer**

(10) **Patent No.:** **US D538,452 S**

(45) **Date of Patent:** **\*\* Mar. 13, 2007**

(54) **SURFACE CONFIGURATION OF A  
TAILLIGHT FOR A VEHICLE**

(75) Inventor: **Peter Pfeiffer**, Boeblingen (DE)

(73) Assignee: **DaimlerChrysler AG**, Stuttgart (DE)

(\*\*) Term: **14 Years**

(21) Appl. No.: **29/251,007**

(22) Filed: **Jan. 4, 2006**

(30) **Foreign Application Priority Data**

Jul. 5, 2005 (DE) ..... 4 05 03 450  
Jul. 5, 2005 (DE) ..... 4 05 03 451

(51) **LOC (8) Cl.** ..... **26-06**

(52) **U.S. Cl.** ..... **D26/28**

(58) **Field of Classification Search** ..... D26/28-36;  
362/459-468, 475-478, 485-487  
See application file for complete search history.

(56) **References Cited**

**U.S. PATENT DOCUMENTS**

D477,098 S \* 7/2003 Moriai et al. .... D26/28  
D483,890 S \* 12/2003 Lin ..... D26/28  
D498,860 S \* 11/2004 Kawashima et al. .... D26/28  
D501,053 S \* 1/2005 Kamimura et al. .... D26/28  
D507,991 S 8/2005 Pfeiffer et al.

\* cited by examiner

*Primary Examiner*—Marcus A. Jackson

(74) *Attorney, Agent, or Firm*—Crowell & Moring LLP

(57) **CLAIM**

The ornamental design for a surface configuration of a taillight for a vehicle, as shown and described.

**DESCRIPTION**

This application is related to the following co-pending application, of the inventor, filed on even date herewith: application Ser. No. 29/245,989, entitled “Surface Configuration of a Vehicle, Toy, and/or Other Replicas”.

This application is also related to co-pending application Ser. No. 29/186,974, entitled “Surface Configuration of a Taillight for a Vehicle”.

FIG. 1 is a perspective view of a first embodiment of a surface configuration of a taillight for a vehicle according to my novel design;

FIG. 2 is a front view thereof; and

FIG. 3 is a side view thereof.

FIG. 4 is a perspective view of a second embodiment of the surface configuration of a taillight for a vehicle according to my novel design;

FIG. 5 is a front view thereof; and,

FIG. 6 is a side view thereof.

The broken lines are for illustrative purposes only and form no part of the claimed design. Also enclosed is a set of photographs of an embodiment of the design.

**1 Claim, 4 Drawing Sheets**

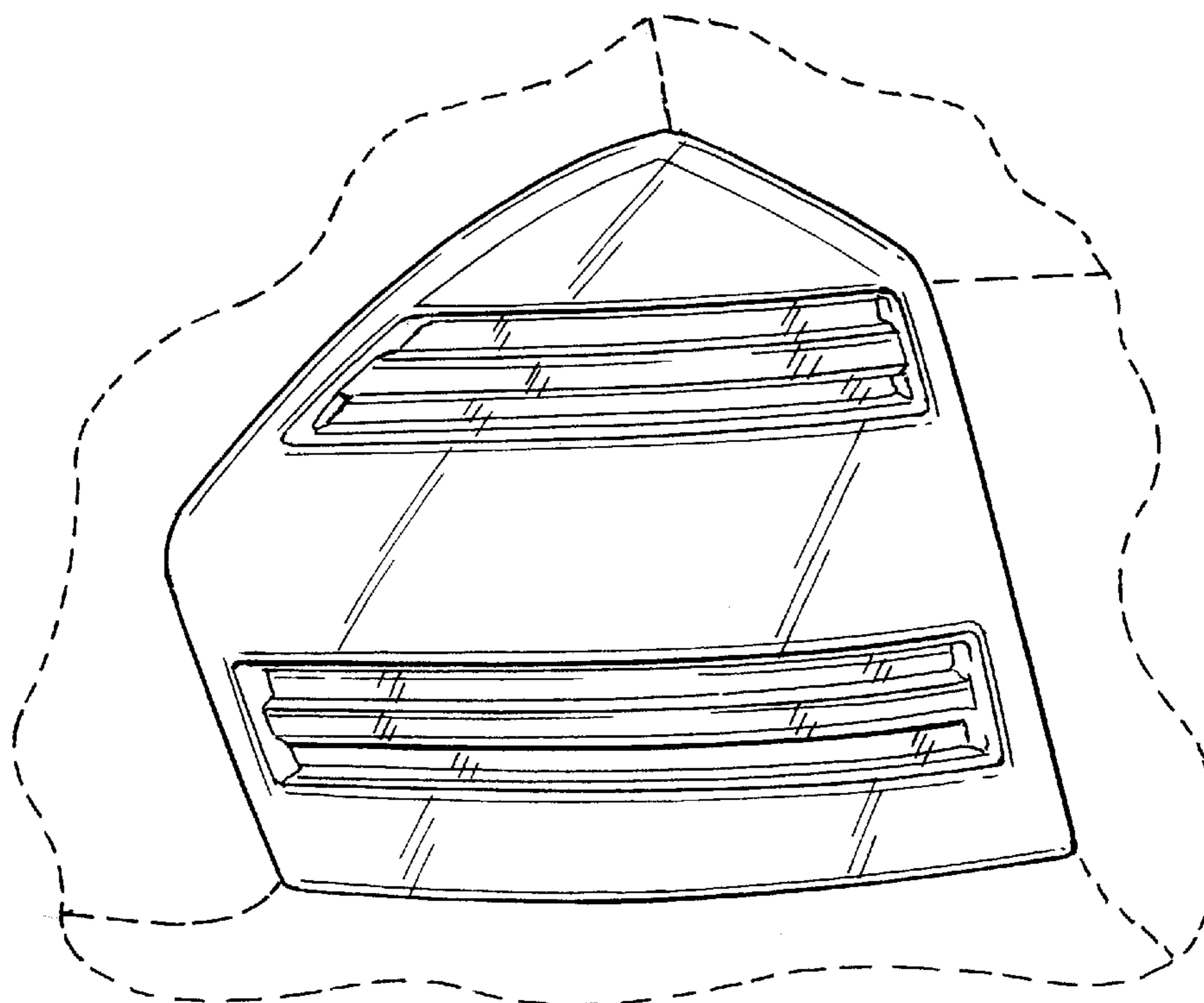

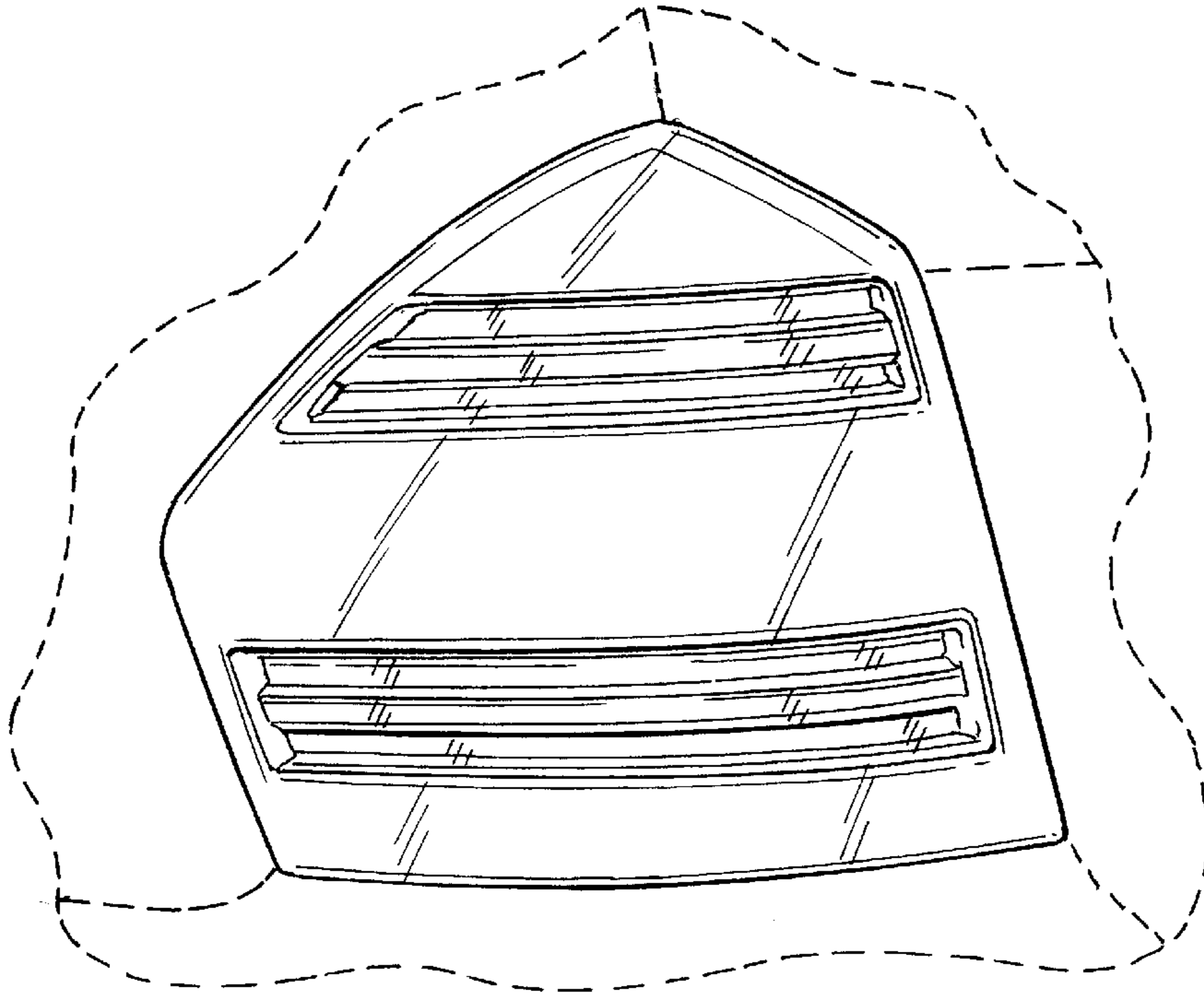

FIG. 1

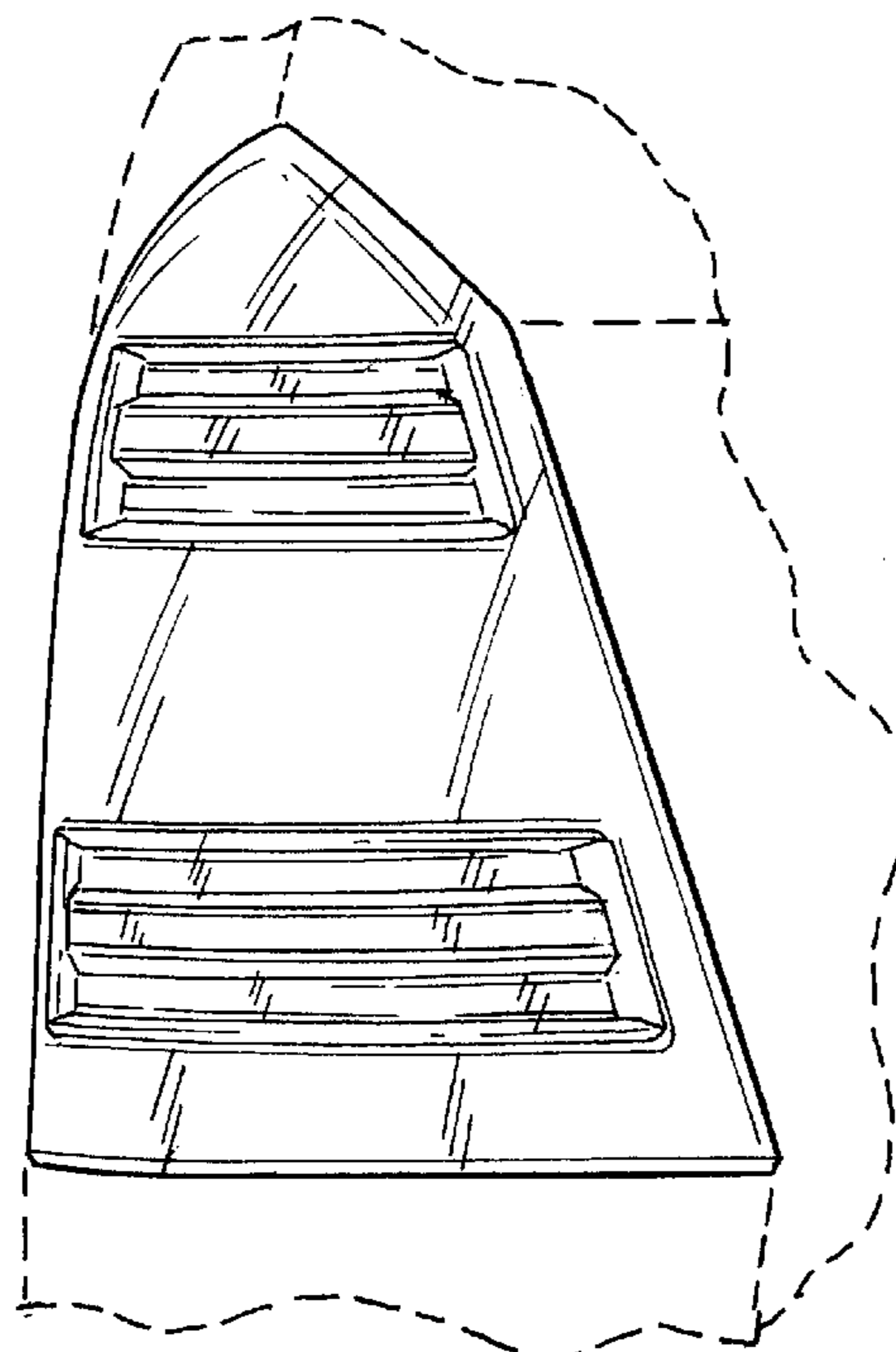

FIG. 2

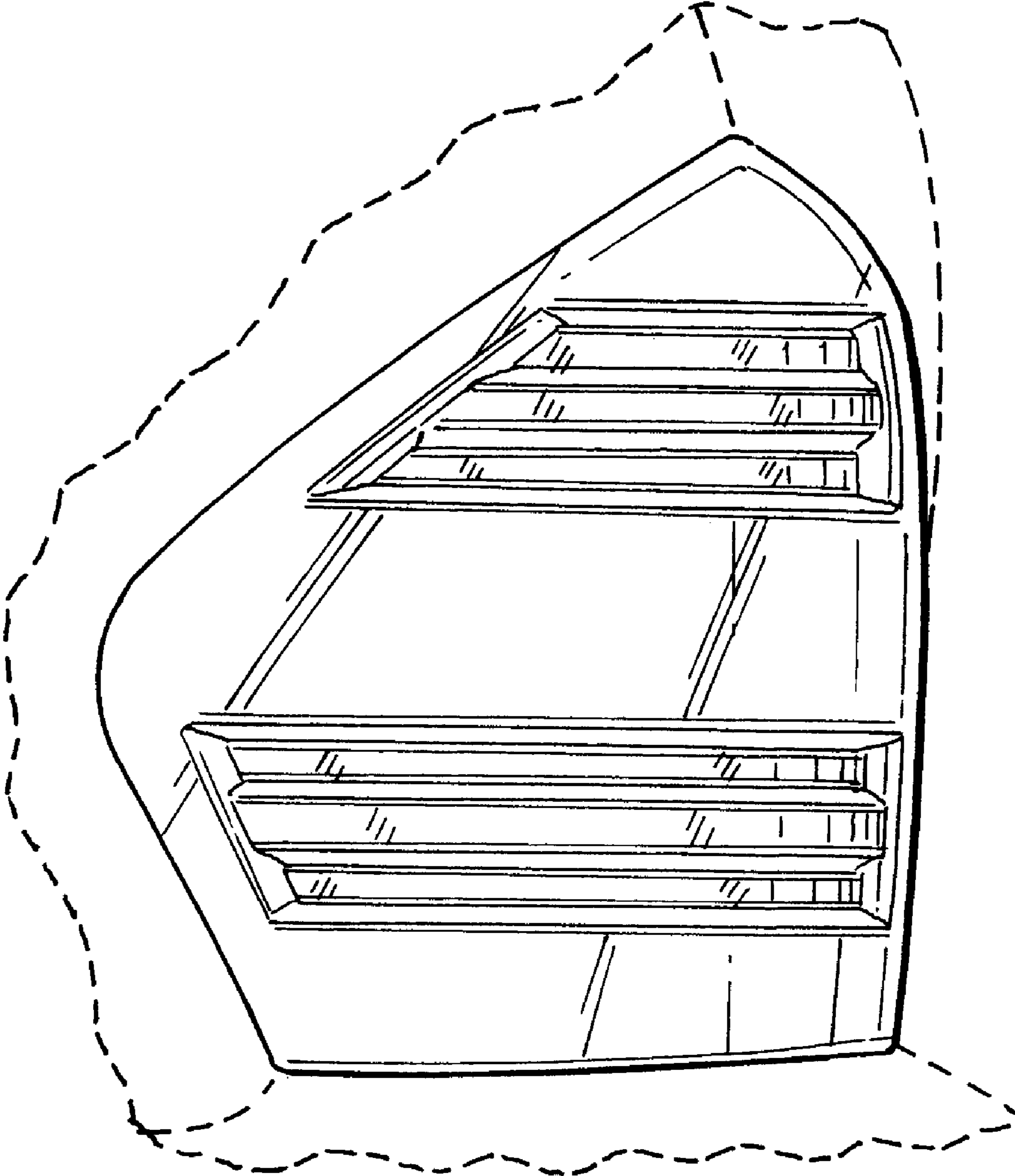

FIG. 3

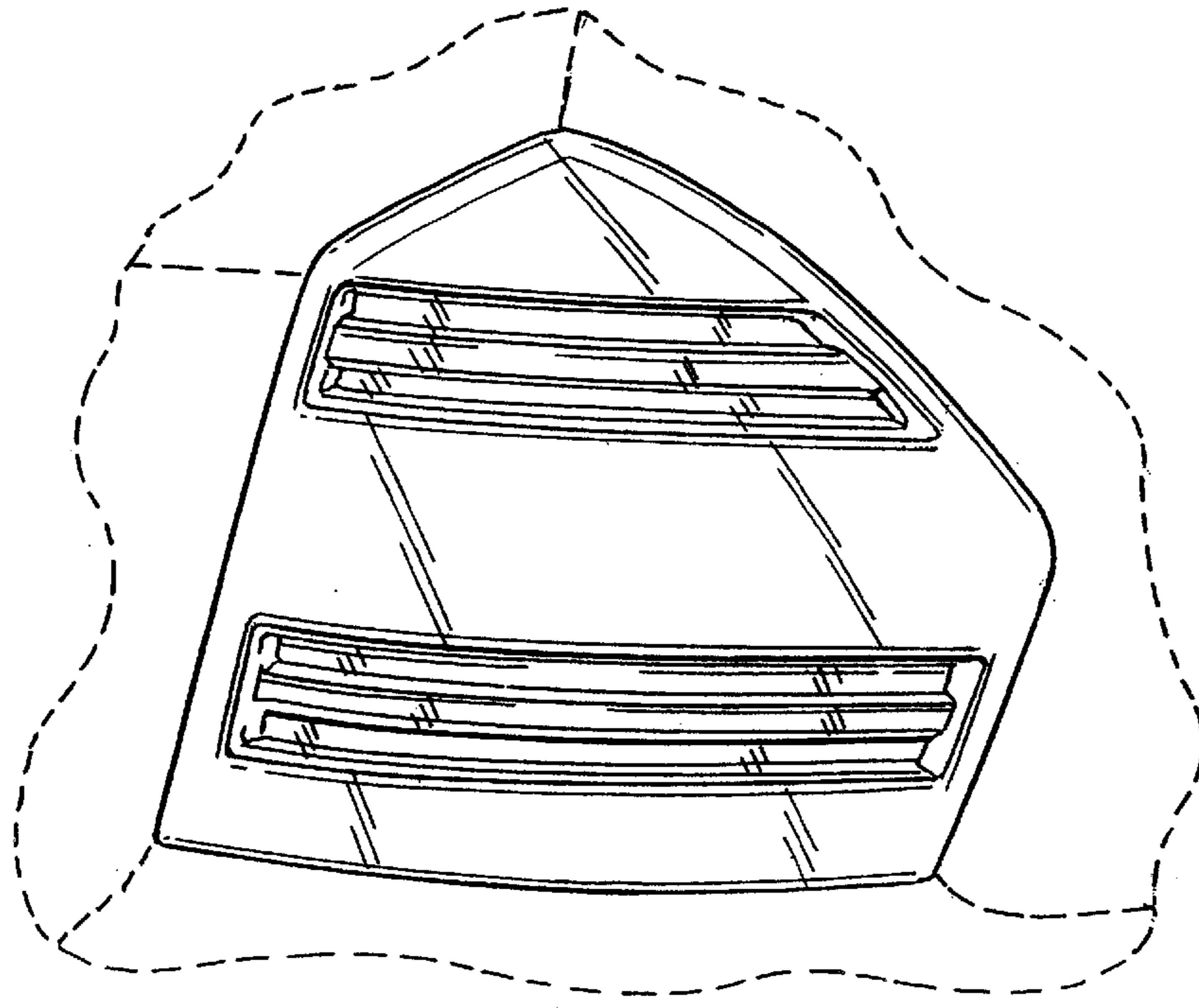

FIG. 4

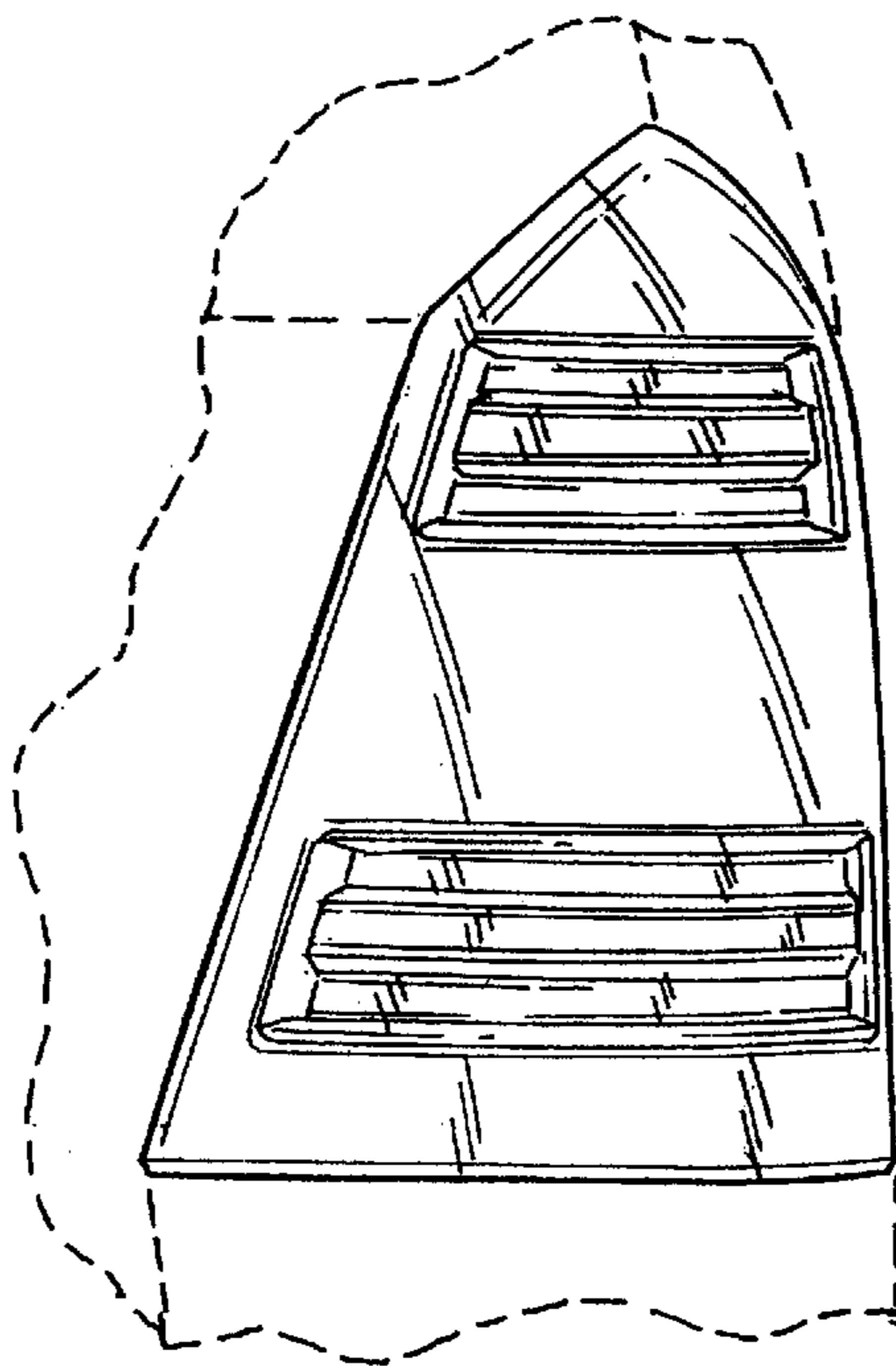

FIG. 5

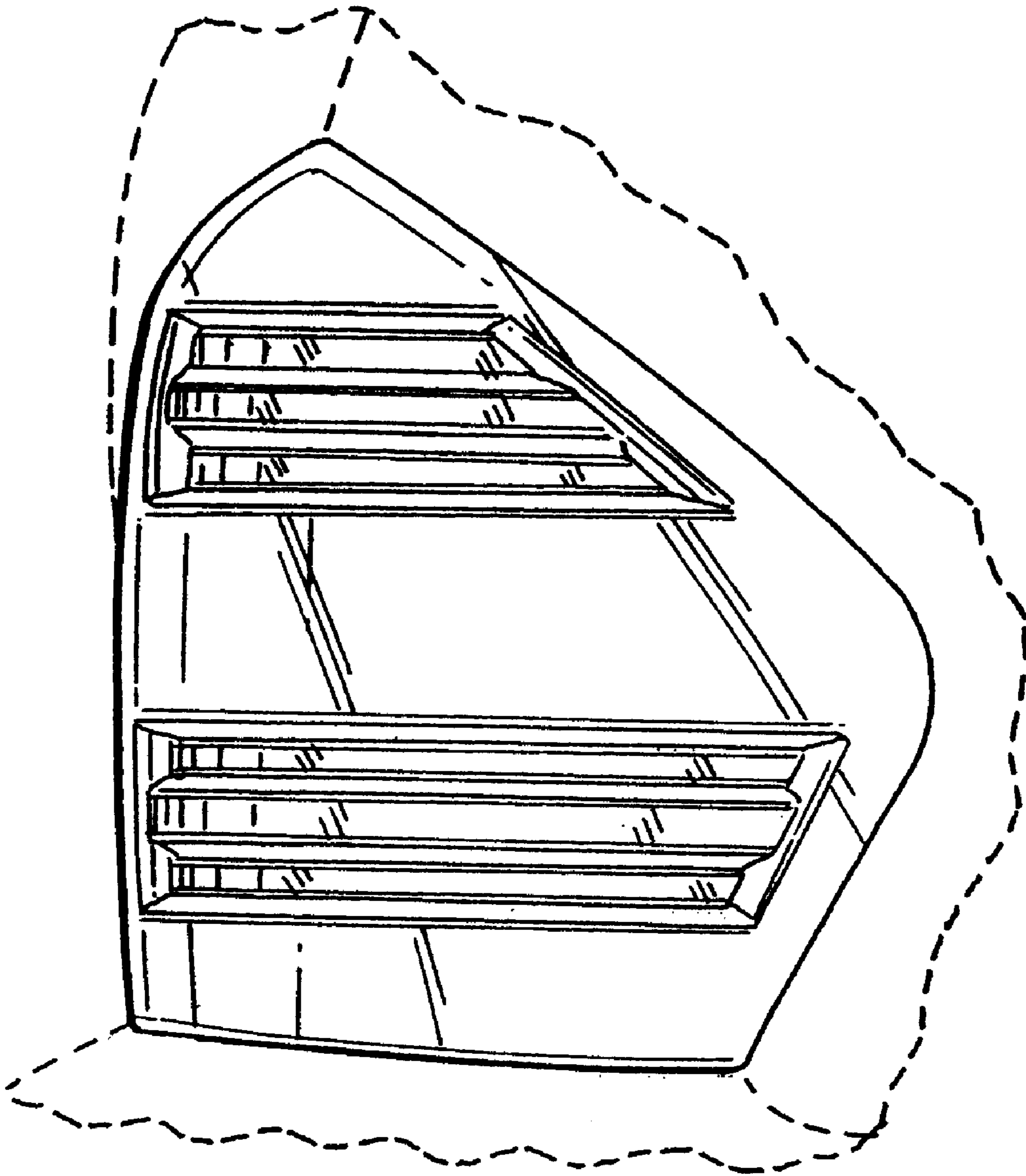

FIG. 6