



US00D538305S

(12) **United States Design Patent** (10) **Patent No.:** **US D538,305 S**  
**Smith et al.** (45) **Date of Patent:** **\*\* Mar. 13, 2007**

(54) **EXCAVATOR TOOL CARRIER WITH CAB**

(75) Inventors: **Jeffrey D. Smith**, Guthrie, OK (US);  
**Cody L. Sewell**, Perry, OK (US);  
**Michael T. Lumbers**, Perry, OK (US)

(73) Assignee: **The Charles Machine Works, Inc.**,  
Perry, OK (US)

(\*\*) Term: **14 Years**

(21) Appl. No.: **29/254,223**

(22) Filed: **Feb. 17, 2006**

(51) **LOC (8) Cl.** ..... **15-03**

(52) **U.S. Cl.** ..... **D15/30**

(58) **Field of Classification Search** ..... D15/10,  
D15/22-26, 28, 30; 180/89.1, 14 R, 89.12,  
180/89.13, 900, 9.1, 9.2, 9.62; 29/401.1;  
37/379, 248; 414/694, 699, 722-724, 660,  
414/685, 698, 719, 743, 687, 688

See application file for complete search history.

(56) **References Cited**

**U.S. PATENT DOCUMENTS**

4,571,147 A	2/1986	Schaeff	
4,650,393 A	3/1987	Denda	
4,693,662 A	9/1987	Haringer	
6,071,066 A	6/2000	Braud	
D432,144 S	* 10/2000	Kraft et al.	D15/30
D432,145 S	* 10/2000	Kraft et al.	D15/30
D433,689 S	* 11/2000	Kraft et al.	D15/30
D436,605 S	* 1/2001	Shaw et al.	D15/30
D450,067 S	* 11/2001	Murakami et al.	D15/25
D450,331 S	* 11/2001	Murakami et al.	D15/25
D458,941 S	6/2002	Miyanishi et al.	
D464,661 S	10/2002	Dahl et al.	
D468,754 S	1/2003	Dershem et al.	
D474,481 S	5/2003	Hara	
D487,100 S	* 2/2004	Tokach et al.	D15/30
D494,986 S	* 8/2004	Tokach et al.	D15/30
6,804,903 B1	10/2004	Cooper	
D511,531 S	11/2005	Sewell et al.	
D523,874 S	6/2006	Hagele	
D527,027 S	* 8/2006	Smith et al.	D15/24
2005/0169738 A1	8/2005	Holt	

**FOREIGN PATENT DOCUMENTS**

EP	1357232 A2	4/2003
JP	2000291043 A1	10/2000
JP	2003138593 A1	5/2003
JP	20031650952 A1	6/2003

**OTHER PUBLICATIONS**

Takeuchi, "All The Power Four Times The Versatility",  
article, no date.

Equipment Today, "A "Tired" Excavating Alternative",  
article, Sep. 2003.

JC Bamford Excavators Ltd., "The JCB Backhoe Loader",  
page from website—www.jcb.com, date unavailable.

JC Bamford Excavators Ltd., "The JCB Skid Steer Loader",  
page from website—www.jcb.com, date unavailable.

Takeuchi, "TB145 Compact Excavator", page from web-  
site—www.takeuchi-us.com, date unavailable.

BOBCAT, "Bobcat 323 Compact Excavator", page from  
website—www.bobcat.com, date unavailable.

\* cited by examiner

*Primary Examiner*—Stella Reid

*Assistant Examiner*—Mark Goodwin

(74) *Attorney, Agent, or Firm*—Tomlinson & O'Connell,  
PC

(57) **CLAIM**

The ornamental design for an excavator tool carrier with  
cab, as shown and described.

**DESCRIPTION**

FIG. 1 is a front elevational view of an excavator tool carrier  
with cab showing our new design;

FIG. 2 is a front top right elevational view thereof;

FIG. 3 is a front top left elevational view thereof;

FIG. 4 is a rear top left elevational view thereof;

FIG. 5 is a rear top right elevational view thereof;

FIG. 6 is a left perspective view thereof;

FIG. 7 is a front perspective view thereof;

FIG. 8 is a right side perspective view thereof; and,

FIG. 9 is a top elevation view thereof.

The broken line showing in FIGS. 1-9 is included for the  
purpose of illustrating environment and forms no part of the  
claimed design.

**1 Claim, 9 Drawing Sheets**

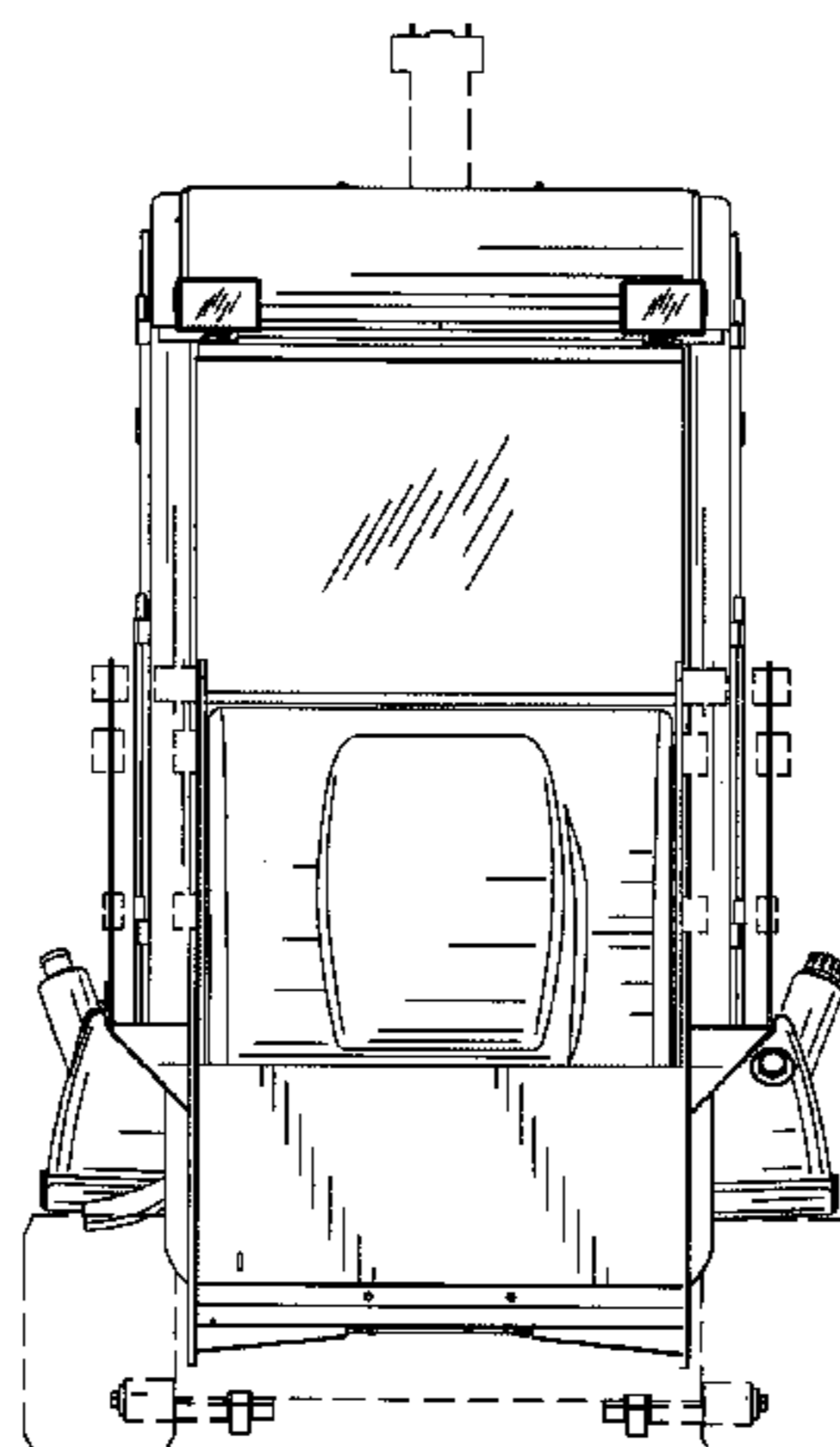

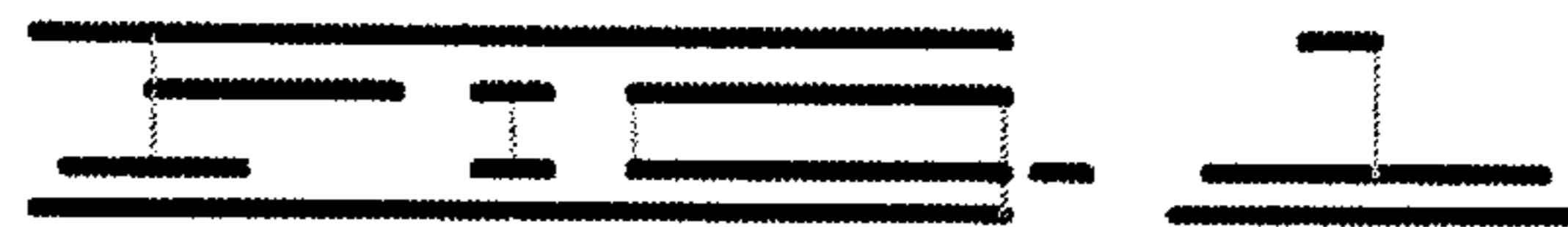
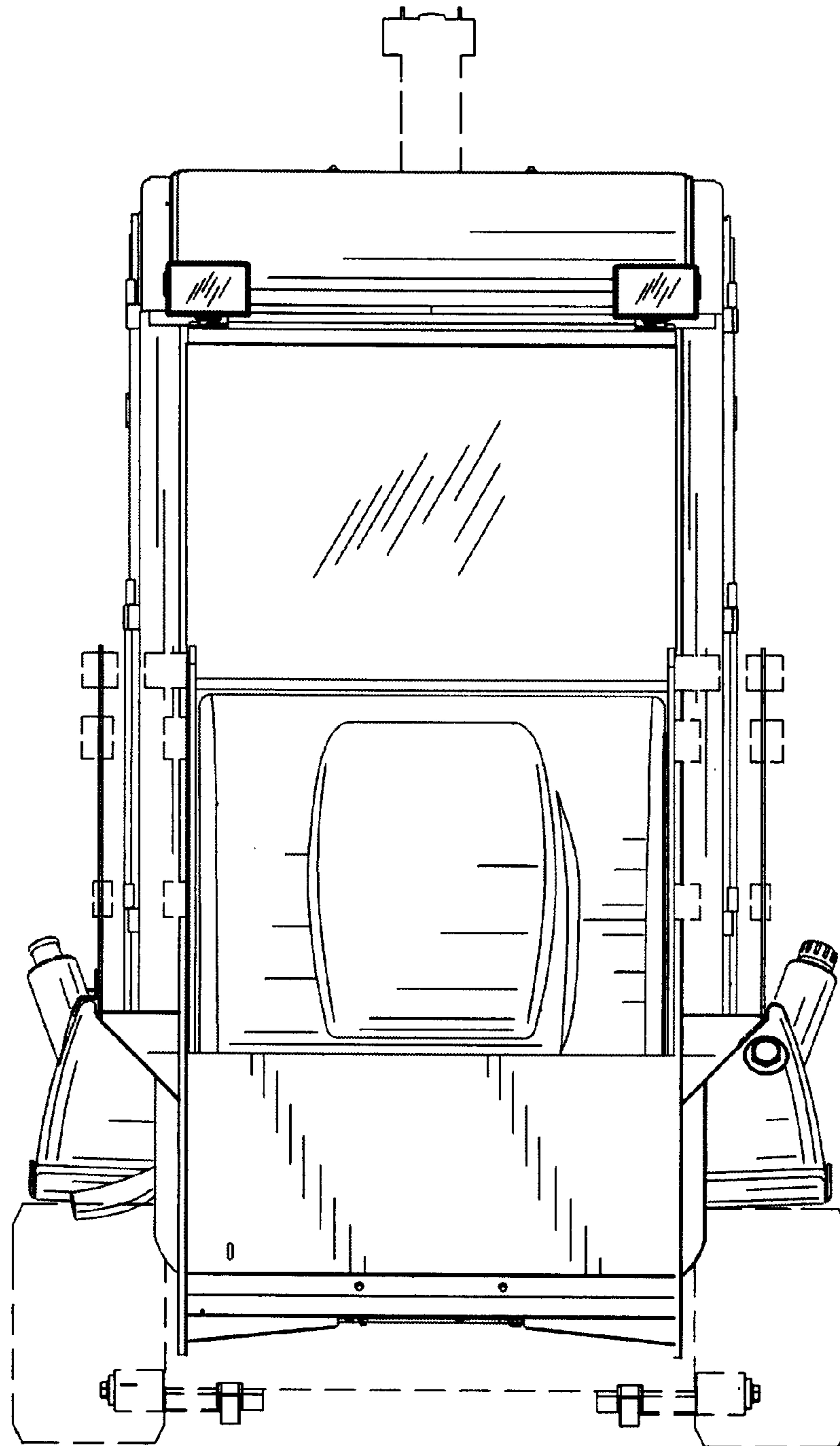

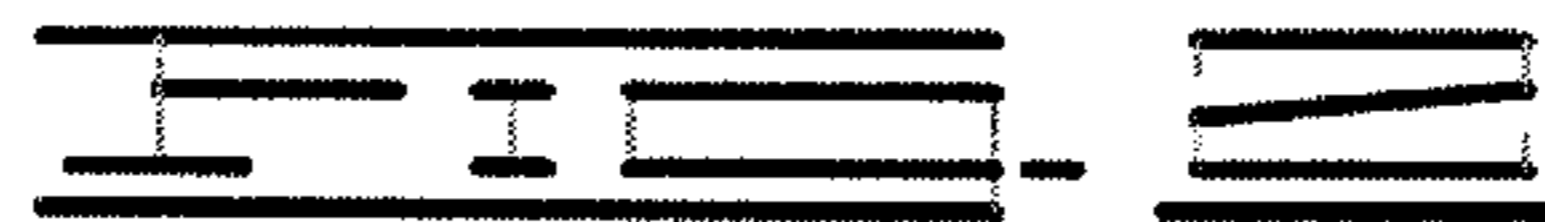
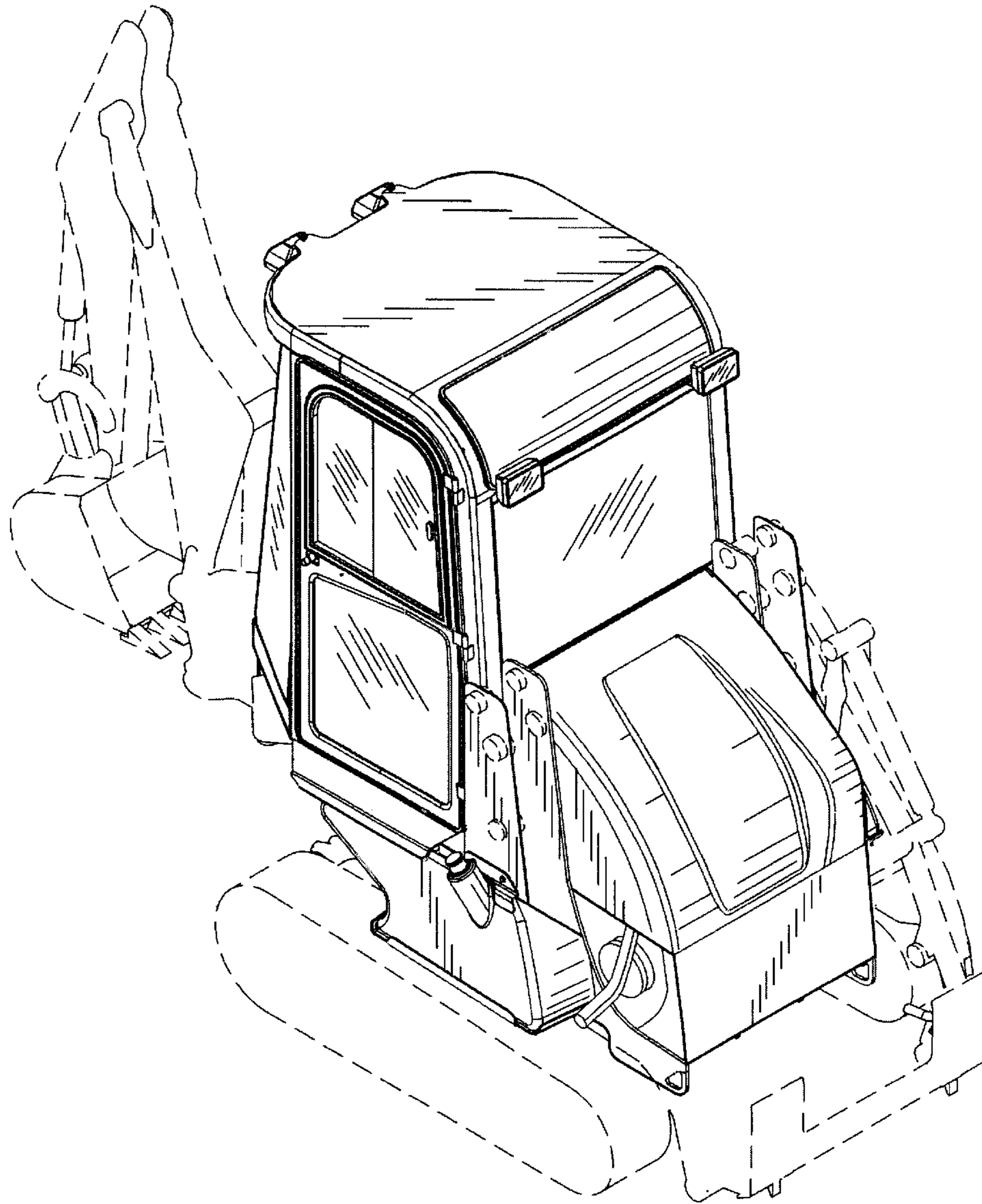

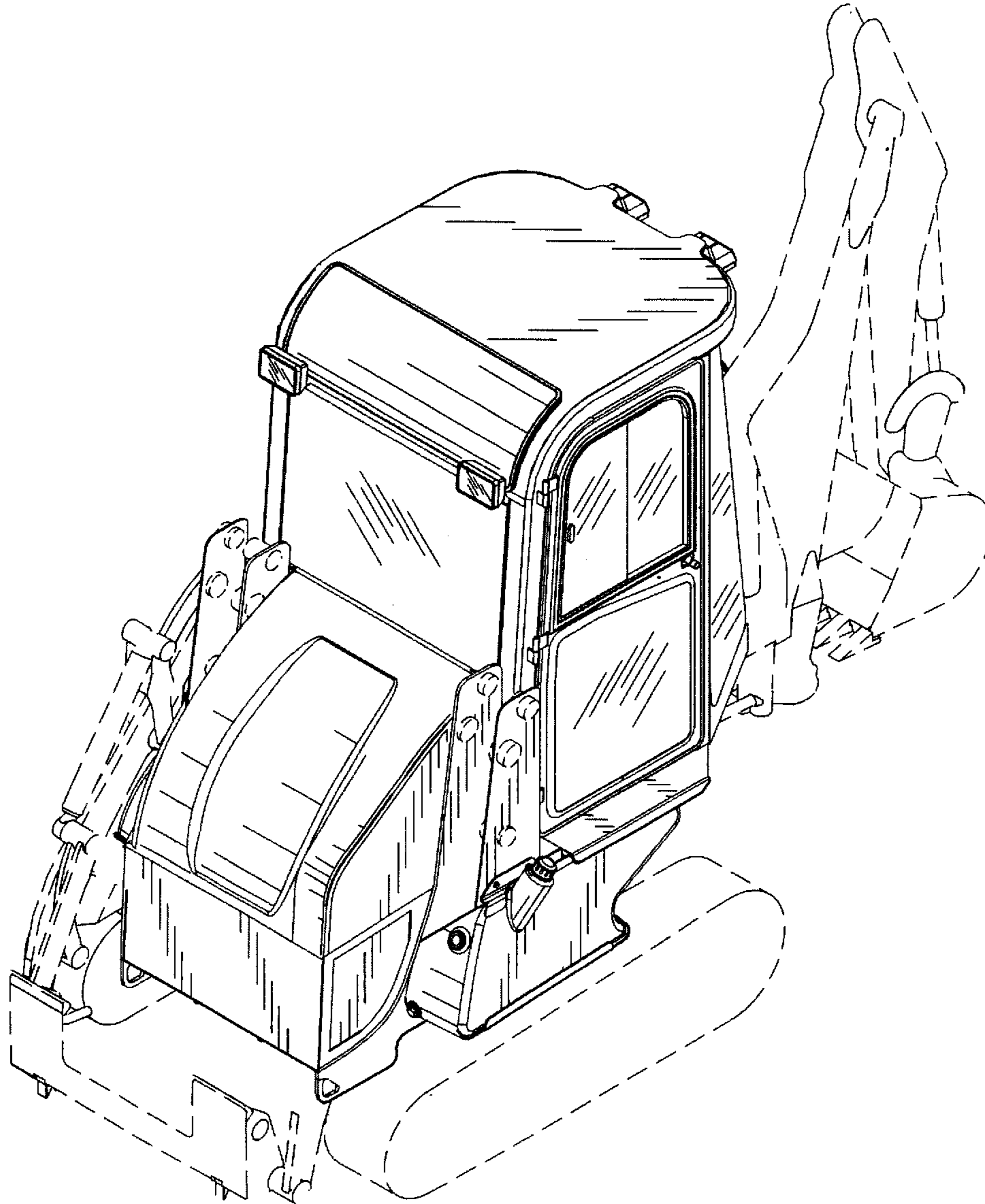

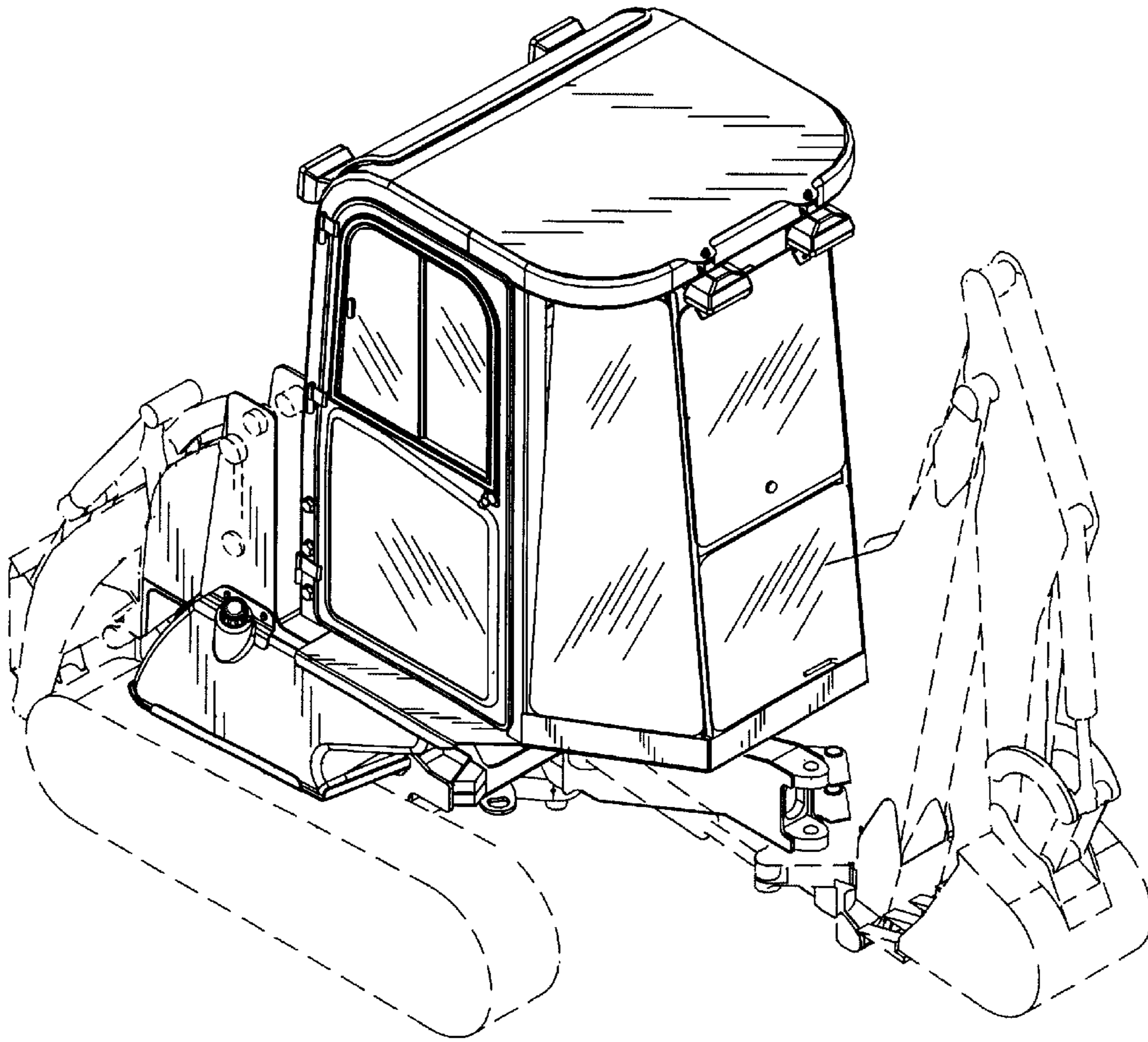

FIG. 4

