



US00D537854S

(12) **United States Design Patent** (10) **Patent No.:** **US D537,854 S**
Tong (45) **Date of Patent:** **** Mar. 6, 2007**

(54) **CUTTING INSERT**

D343,400 S 1/1994 Lindstedt et al.
5,315,908 A 5/1994 Mihic

(75) Inventor: **Nelson Pao Chung Tong**, Massilon, OH (US)

(Continued)

(73) Assignee: **Manchester Tool Company**, Akron, OH (US)

OTHER PUBLICATIONS

(**) Term: **14 Years**

ISCAR (Member IMC Group), Heliface Face Machining, Iscar Turn Plus Catalog, Oct. 2001, p. G51, United States of America.

(21) Appl. No.: **29/255,916**

ISCAR (Member IMC Group), Self-Grip Slitting Cutters, Iscar Turn Plus Catalog, Oct. 2001, p. F8, United States of America.

(22) Filed: **Mar. 14, 2006**

Sandvik Coromant, T-Max Q-Cut inserts (Parting and Grooving), Sandvik Turning Tools And inserts Catalog, Mar. 2000, p. B17, Sweden.

Related U.S. Application Data

Sandvik Coromant, T-Max Q-Cut insert geometries and grades (Parting and Grooving), Sandvik Turning Tools And Inserts Catalog, Mar. 2000, p. B7, Sweden.

(63) Continuation of application No. 29/220,307, filed on Dec. 29, 2004, now abandoned.

(51) **LOC (8) Cl.** **15-09**

Primary Examiner—Antoine D. Davis

(52) **U.S. Cl.** **D15/139**

Assistant Examiner—Patricia Palasik

(58) **Field of Classification Search** D15/138, D15/139; 407/35, 42, 112-119

(74) *Attorney, Agent, or Firm*—Tarolli, Sundheim, Covell & Tummino, LLP

See application file for complete search history.

(57) **CLAIM**

(56) **References Cited**

The ornamental design for a cutting insert, as shown and described.

U.S. PATENT DOCUMENTS

DESCRIPTION

- 4,340,325 A 7/1982 Gowanlock
- D275,760 S 10/1984 Cochran
- 4,558,974 A 12/1985 Pano
- D284,011 S * 5/1986 Pano D15/139
- 4,629,372 A 12/1986 Huston
- 4,778,311 A 10/1988 Niemi
- 4,801,224 A 1/1989 Pettersson et al.
- 4,832,541 A 5/1989 Noguchi et al.
- D306,032 S 2/1990 Mihic
- 4,973,204 A 11/1990 Mihic
- 4,992,008 A 2/1991 Pano
- 5,040,930 A 8/1991 Zinner
- 5,085,541 A 2/1992 Simpson, III
- 5,135,336 A 8/1992 Noguchi et al.
- 5,137,396 A 8/1992 Durschinger
- D329,439 S 9/1992 Gustafsson et al.
- D329,858 S 9/1992 Gustafsson et al.
- 5,161,920 A 11/1992 Zinner
- D338,477 S 8/1993 Mihic

FIG. 1 is a perspective view of a cutting insert showing my new design;
 FIG. 2 is a side elevational view of the cutting insert shown in FIG. 1;
 FIG. 3 is a top plan view of the cutting insert shown in FIG. 1;
 FIG. 4 is a bottom plan view of the cutting insert shown in FIG. 1.
 FIG. 5 is a left end view of the cutting insert shown in FIG. 1; and,
 FIG. 6 is a right end view of the cutting insert shown in FIG. 1.
 The broken lines in FIGS. 1-6 are for illustrative purposes only and do not form part of the invention shown in FIGS. 1-6.

1 Claim, 2 Drawing Sheets

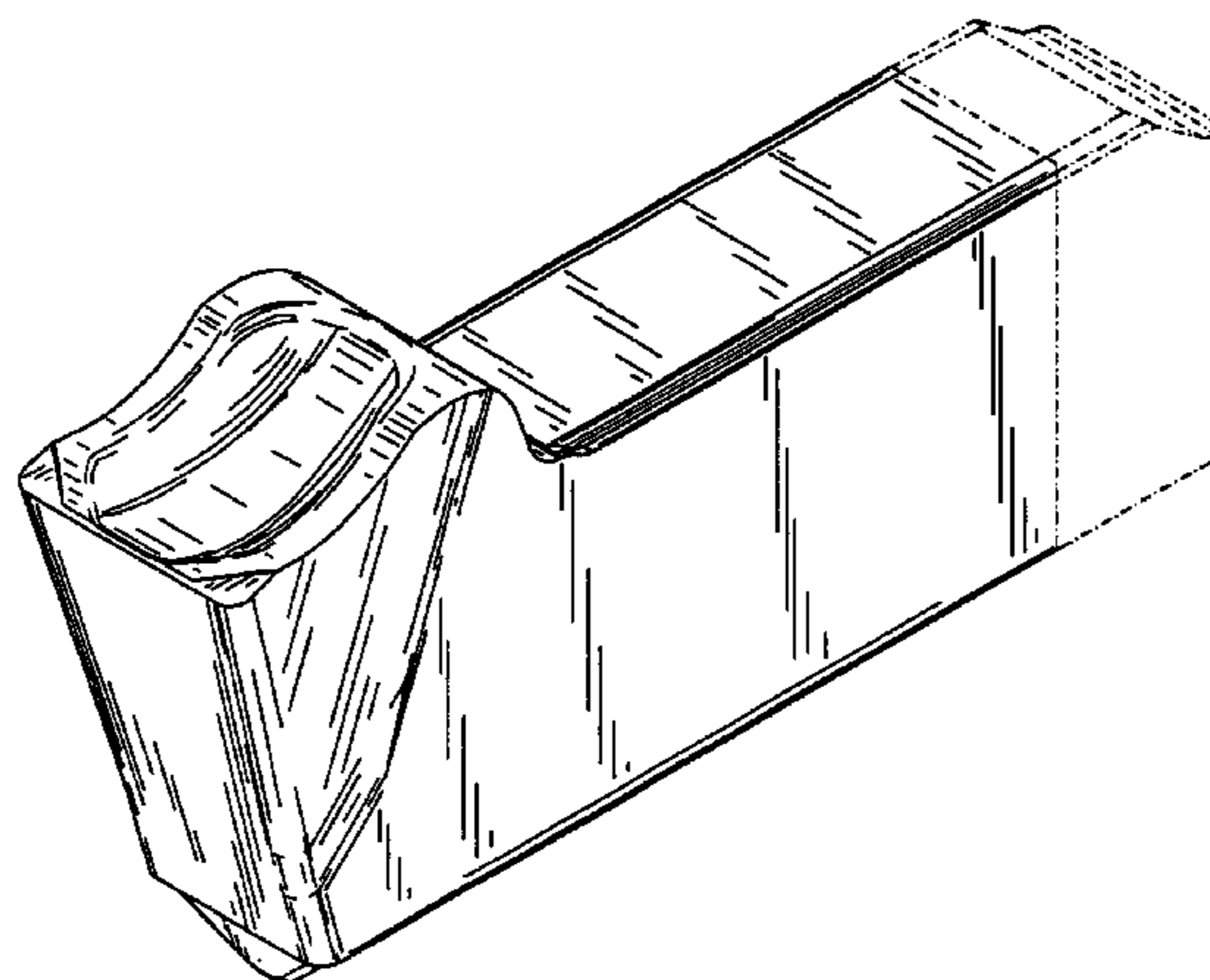

US D537,854 S

Page 2

U.S. PATENT DOCUMENTS					
			5,921,724 A	7/1999	Erickson et al.
			5,975,812 A	11/1999	Friedman
			5,993,118 A	11/1999	Brask et al.
			6,086,291 A	7/2000	Hansson et al.
			6,146,064 A	11/2000	Flolo
			6,238,147 B1	5/2001	Tagtstrom et al.
			RE37,595 E	3/2002	Lindstedt
			6,428,247 B1	8/2002	Friedman
			D470,516 S	2/2003	Andersson
			D470,517 S	2/2003	Andersson
			6,843,620 B2	1/2005	Inayama
			2002/0197119 A1	12/2002	Kinukawa
			* cited by examiner		
D350,549 S	9/1994	Lindstedt et al.			
5,360,298 A	11/1994	Hedlund			
5,375,948 A	12/1994	Lindstedt			
5,382,119 A	1/1995	Mihic			
5,423,639 A	6/1995	Wiman			
5,511,911 A	4/1996	Katbi et al.			
D381,027 S	* 7/1997	Mihic D15/139			
5,676,495 A	10/1997	Katbi et al.			
5,704,737 A	1/1998	Alford			
5,725,334 A	3/1998	Paya			
5,827,017 A	10/1998	Tagtstrom et al.			
5,829,924 A	11/1998	Oshnock et al.			

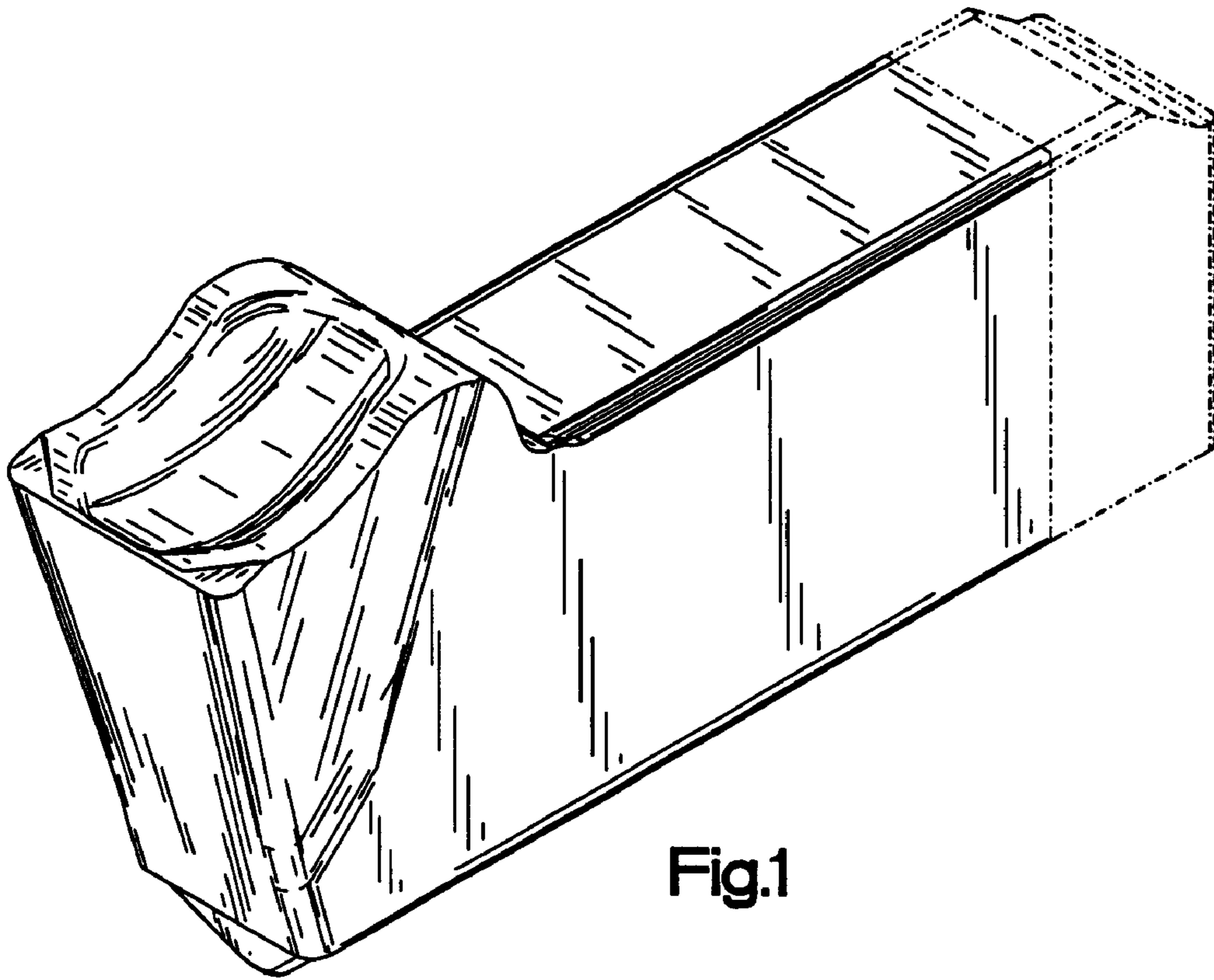

Fig.1

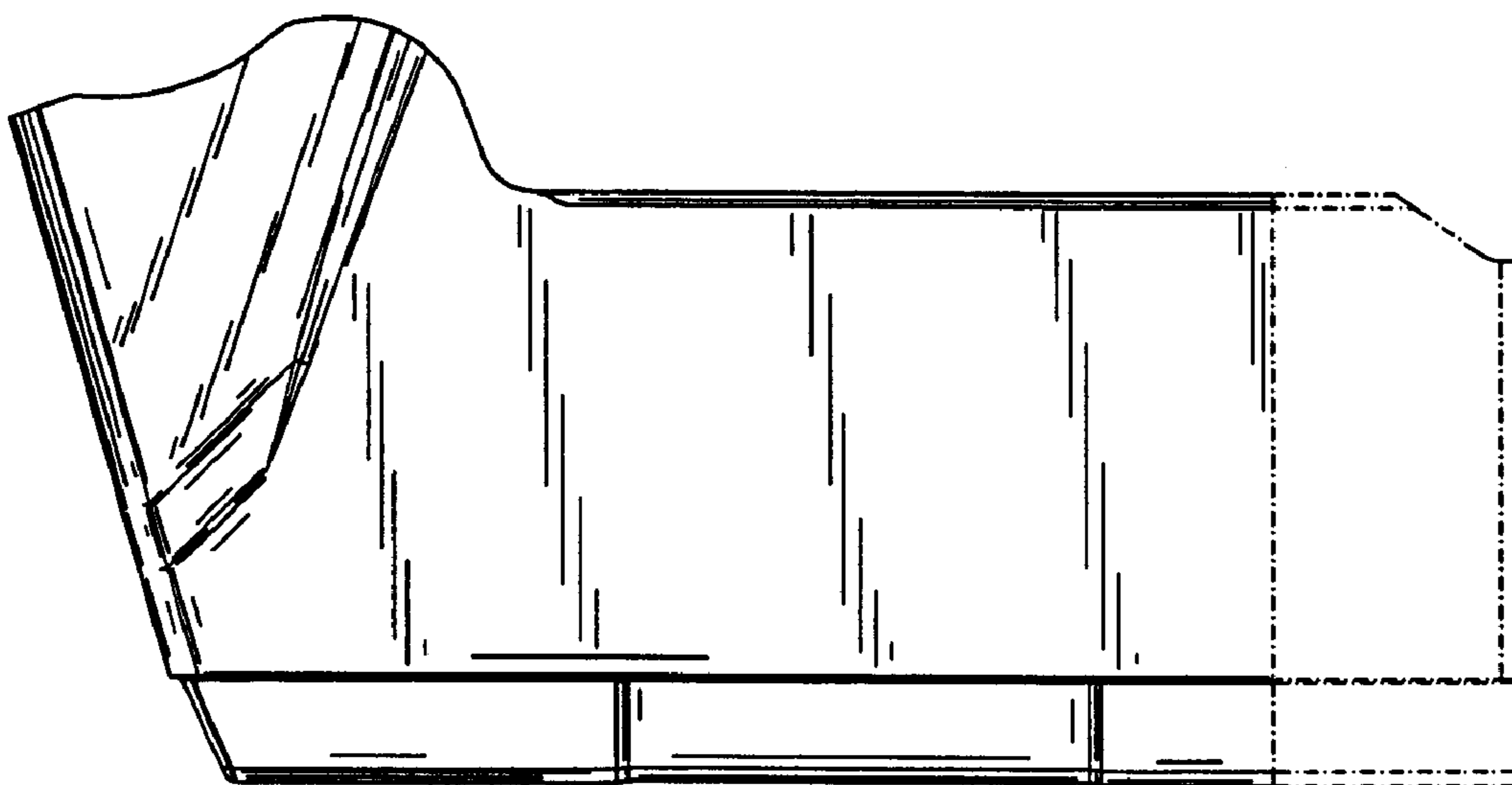

Fig.2

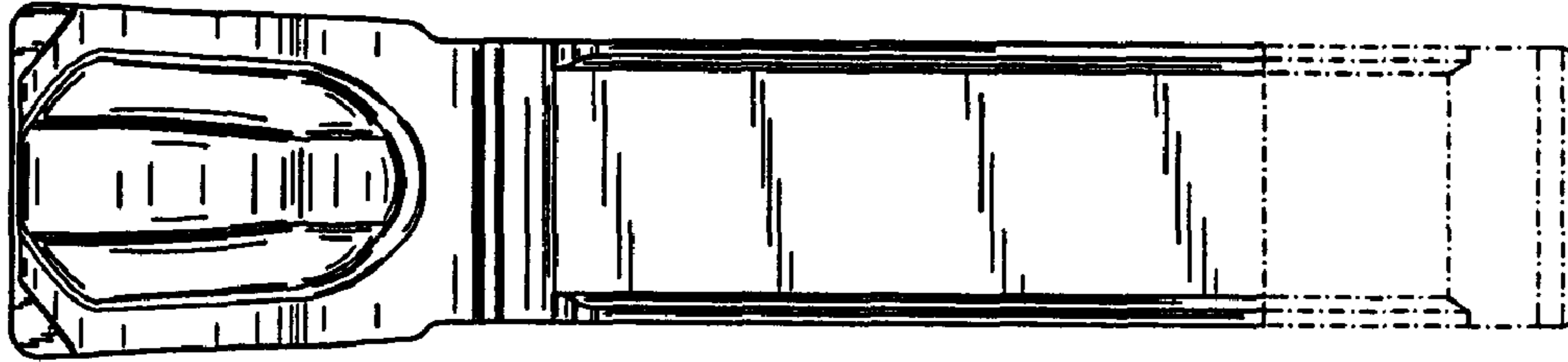

Fig.3

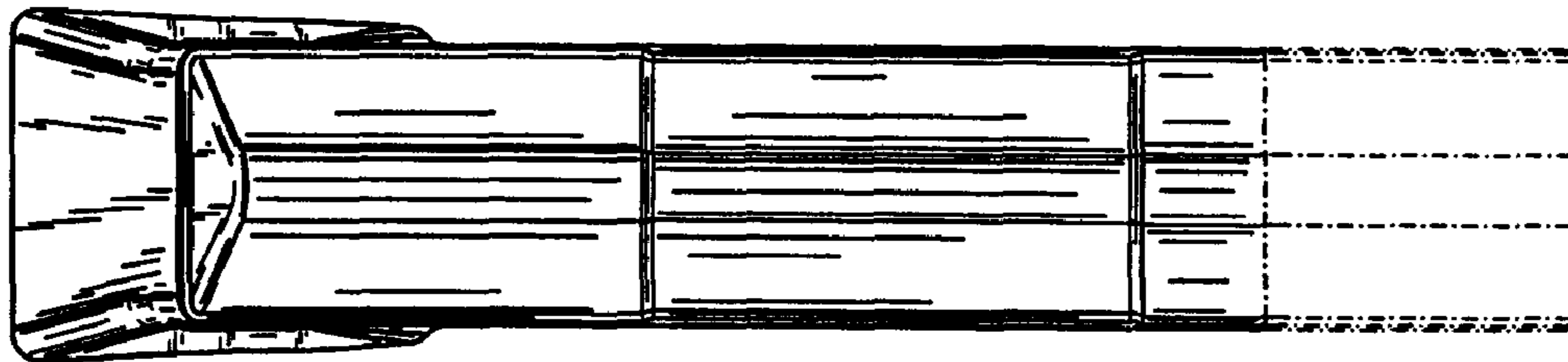

Fig.4

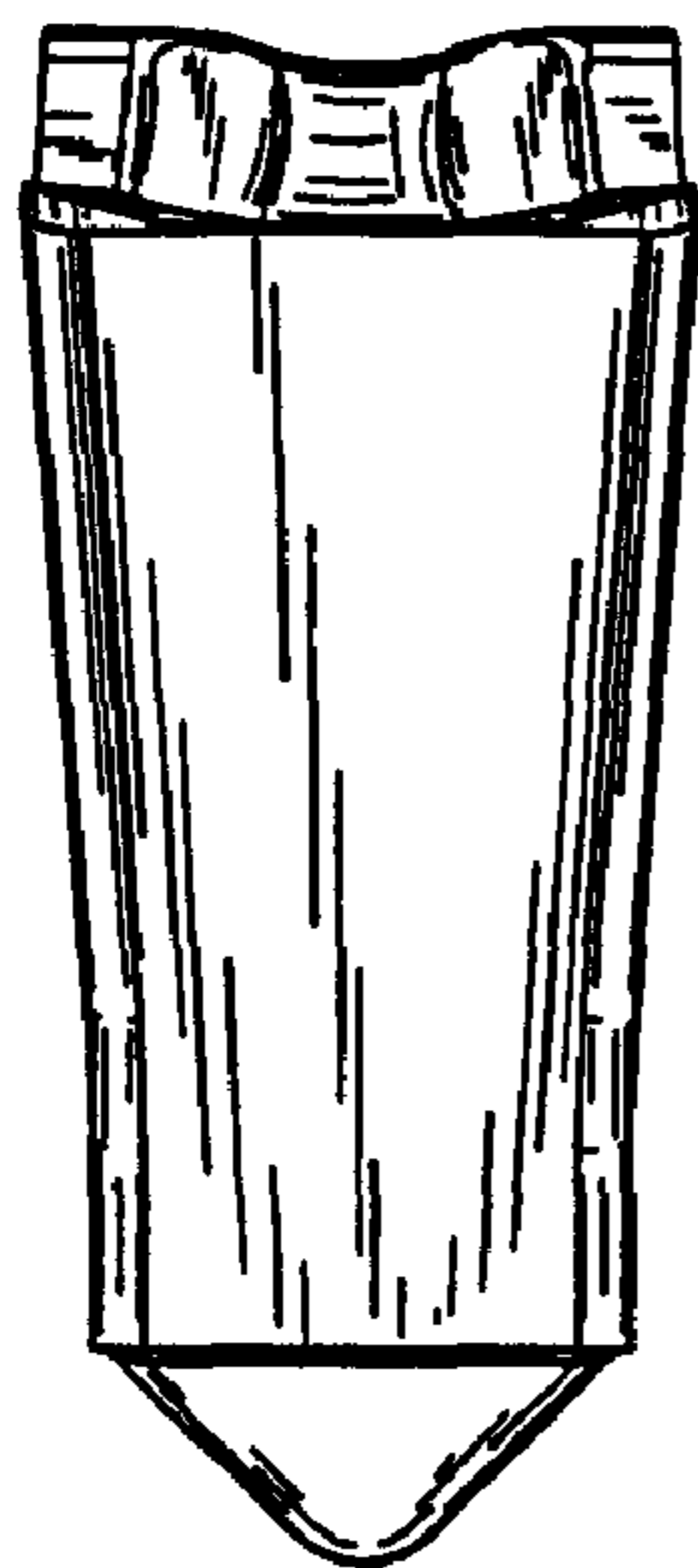

Fig.5

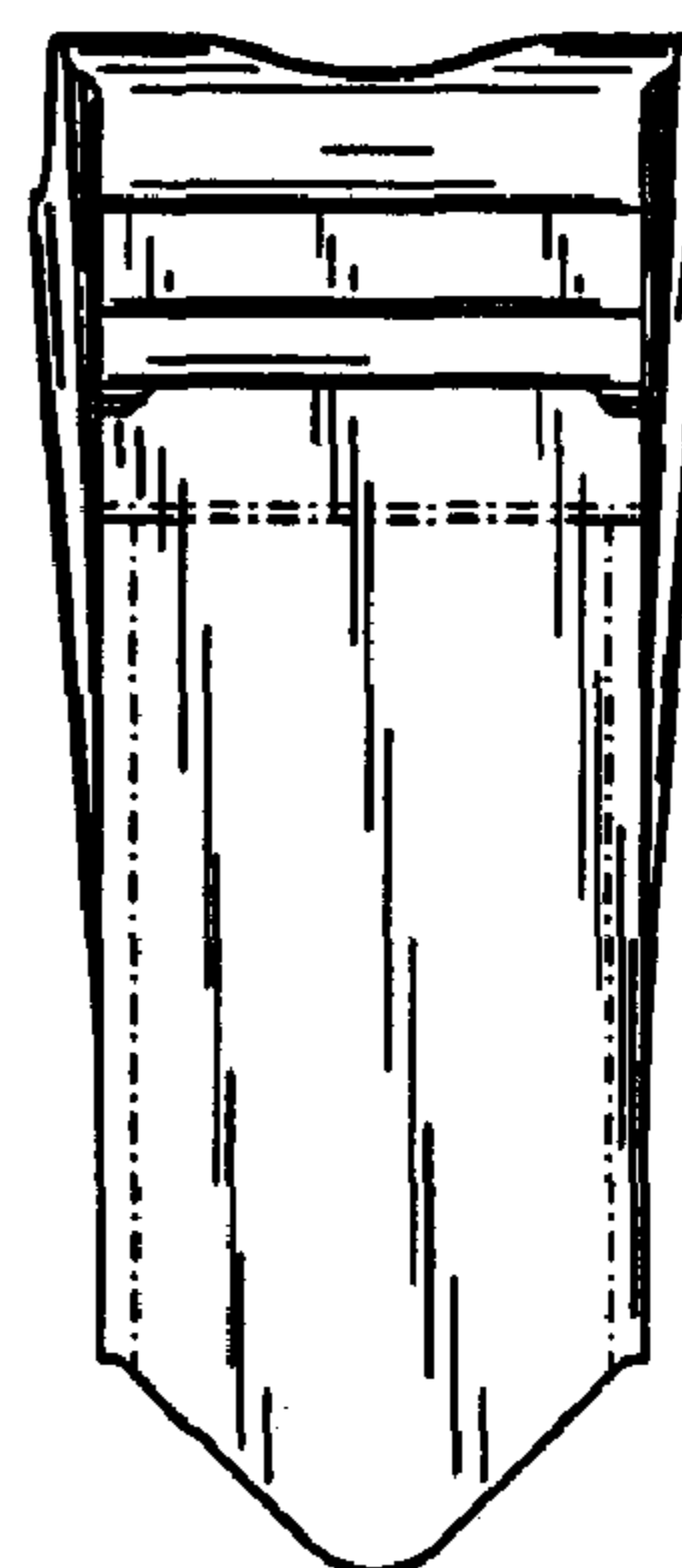

Fig.6