



US00D537698S

(12) **United States Design Patent**  
**Hasegawa**

(10) **Patent No.:** **US D537,698 S**

(45) **Date of Patent:** **\*\* Mar. 6, 2007**

(54) **HAND SHARPENER**

D491,786 S \* 6/2004 Waltzer ..... D8/93  
6,846,229 B1 \* 1/2005 Ranieri ..... 451/312

(75) Inventor: **Katsumi Hasegawa**, Seki (JP)

FOREIGN PATENT DOCUMENTS

(73) Assignee: **Kai R & D Center Co., Ltd.**, Gifu (JP)

JP 955605 6/1996  
JP 1037143 4/1999  
JP D1132065 11/2001

(\*\*) Term: **14 Years**

\* cited by examiner

(21) Appl. No.: **29/232,116**

*Primary Examiner*—Philip S. Hyder

(22) Filed: **Jun. 15, 2005**

*Assistant Examiner*—RoseLynne (Ulm) Cody

(30) **Foreign Application Priority Data**

(74) *Attorney, Agent, or Firm*—Jordan and Hamburg LLP

Jan. 19, 2005 (JP) ..... 2005-001166

(57) **CLAIM**

(51) **LOC (8) Cl.** ..... **08-05**

The ornamental design for a hand sharpener, as shown and described.

(52) **U.S. Cl.** ..... **D8/91**; D8/93

(58) **Field of Classification Search** ..... D8/91,  
D8/93; 76/82, 82.2, 86, 88; 451/312, 319,  
451/540, 548–549, 555, 559  
See application file for complete search history.

**DESCRIPTION**

FIG. 1 is a front view of a hand sharpener according to the invention;

(56) **References Cited**

U.S. PATENT DOCUMENTS

D146,921 S \* 6/1947 Lambert ..... D8/93  
D280,286 S \* 8/1985 Van Asten ..... D8/93  
D303,209 S \* 9/1989 Friel ..... D8/93  
D308,018 S \* 5/1990 Linden et al. .... D8/93  
D310,620 S \* 9/1990 Friel ..... D8/93  
D327,833 S \* 7/1992 Micoley ..... D8/93  
D363,867 S \* 11/1995 Harrison et al. .... D8/63  
D409,891 S \* 5/1999 Friel et al. .... D8/93  
D446,707 S \* 8/2001 Carlson et al. .... D8/91  
D481,285 S \* 10/2003 Moeller et al. .... D8/93

FIG. 2 is a rear view thereof;

FIG. 3 is a plan view thereof;

FIG. 4 is a bottom view thereof;

FIG. 5 is a right side view thereof;

FIG. 6 is a left side view thereof;

FIG. 7 is a front view showing the lid in a closed position;

FIG. 8 is a front view showing the lid in an open position and in section taken along the line 8—8 in FIG. 9 and also showing the internal arrangement of the main body; and,

FIG. 9 is a plan view showing the internal arrangement of the main body.

**1 Claim, 5 Drawing Sheets**

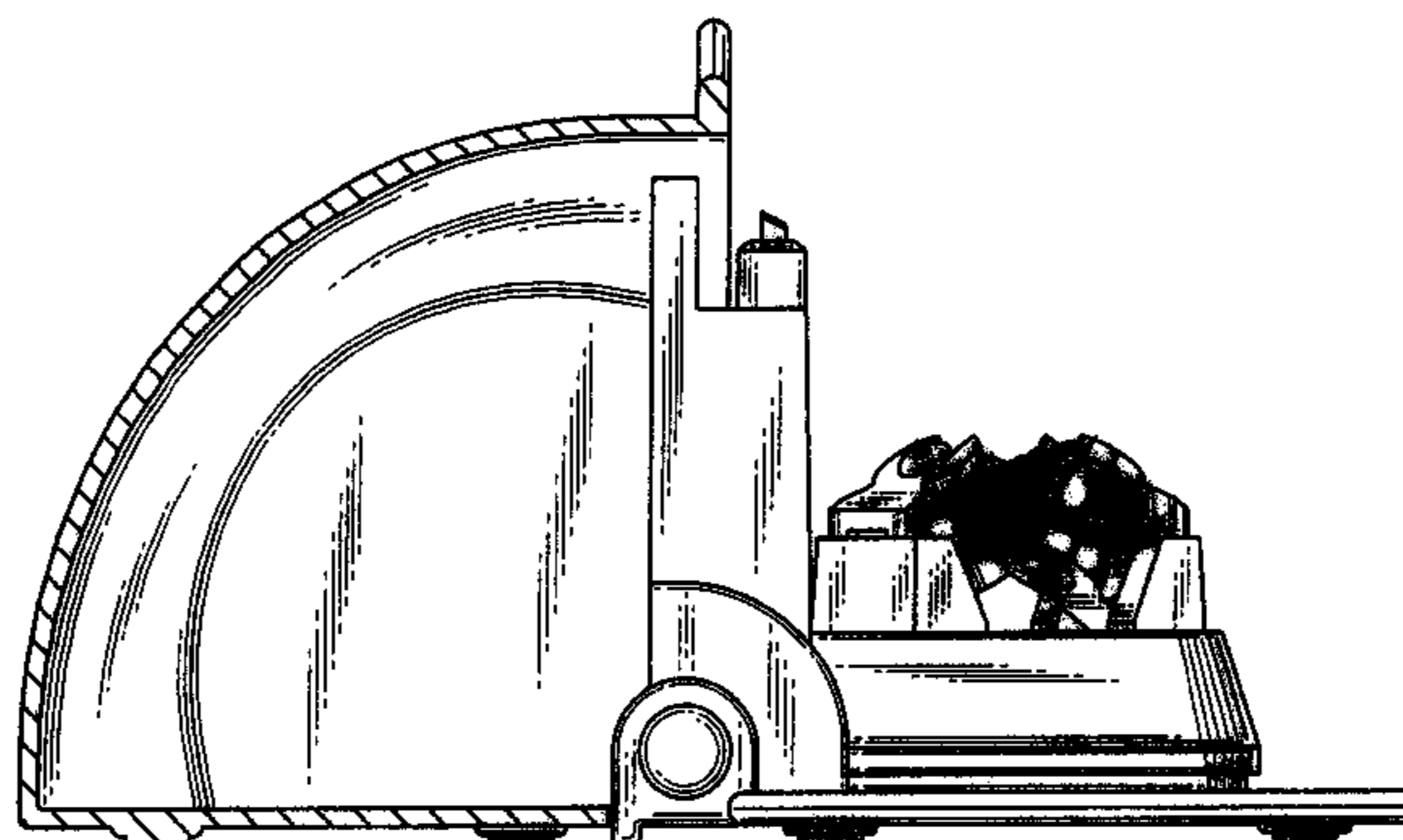
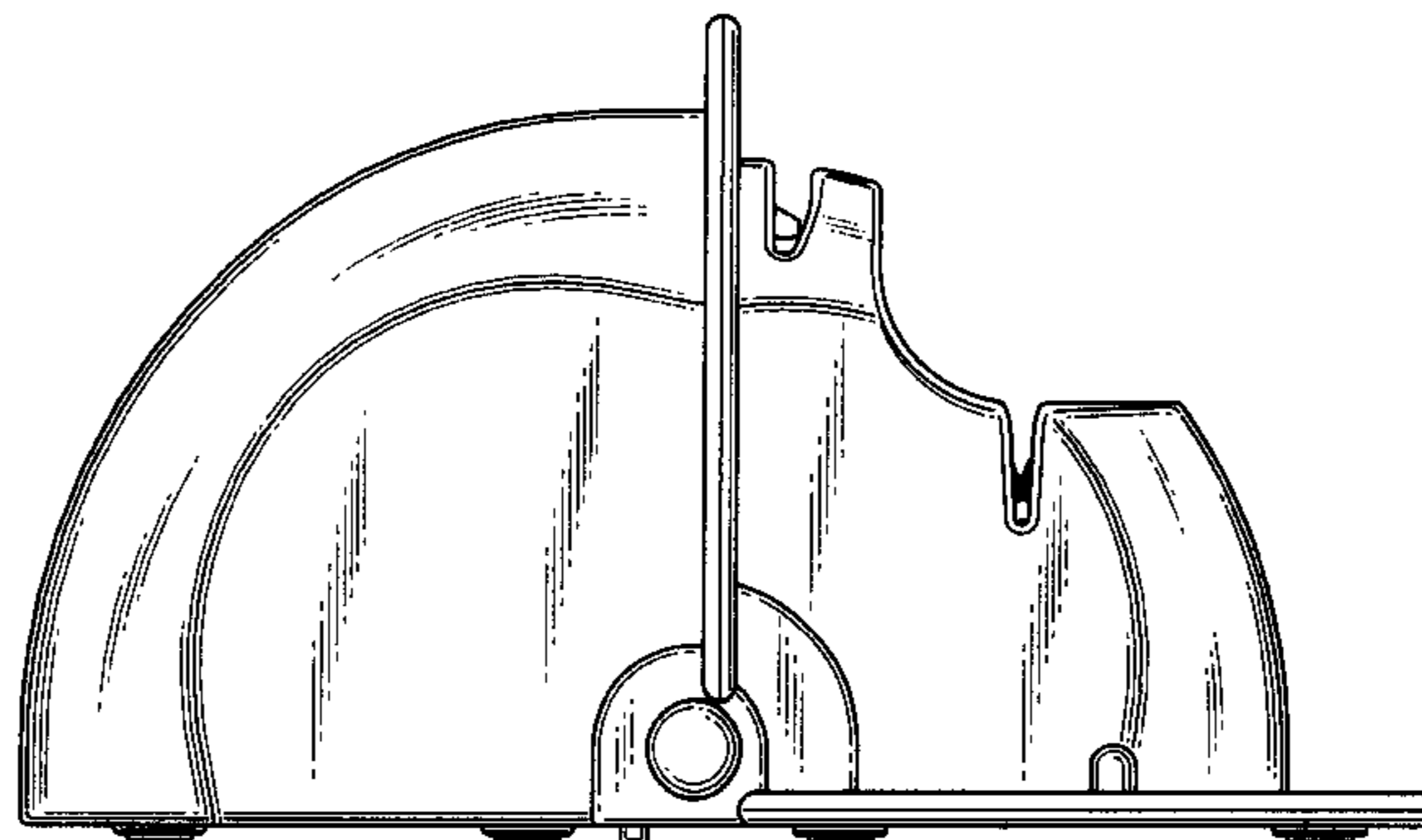

Fig. 1

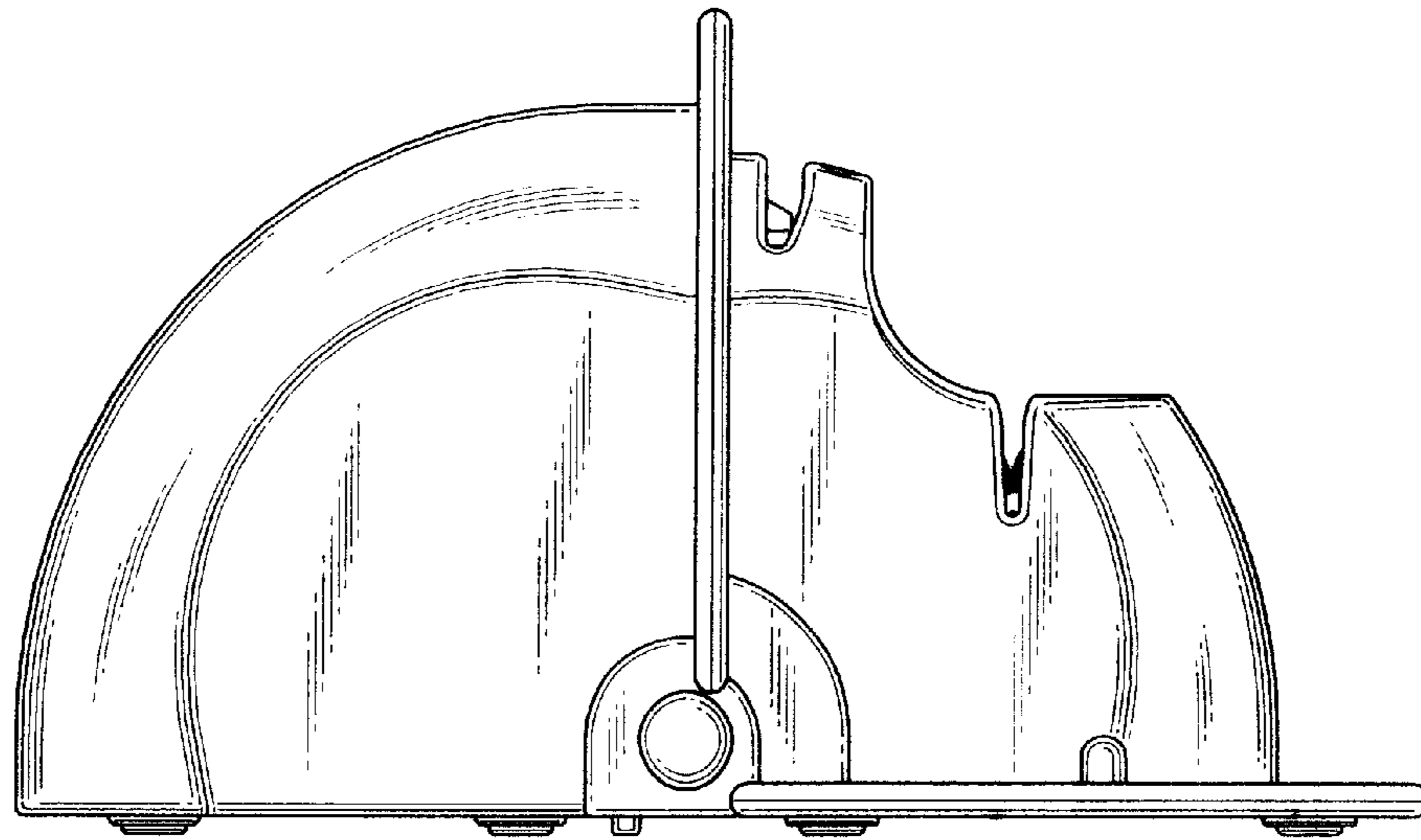

Fig. 2

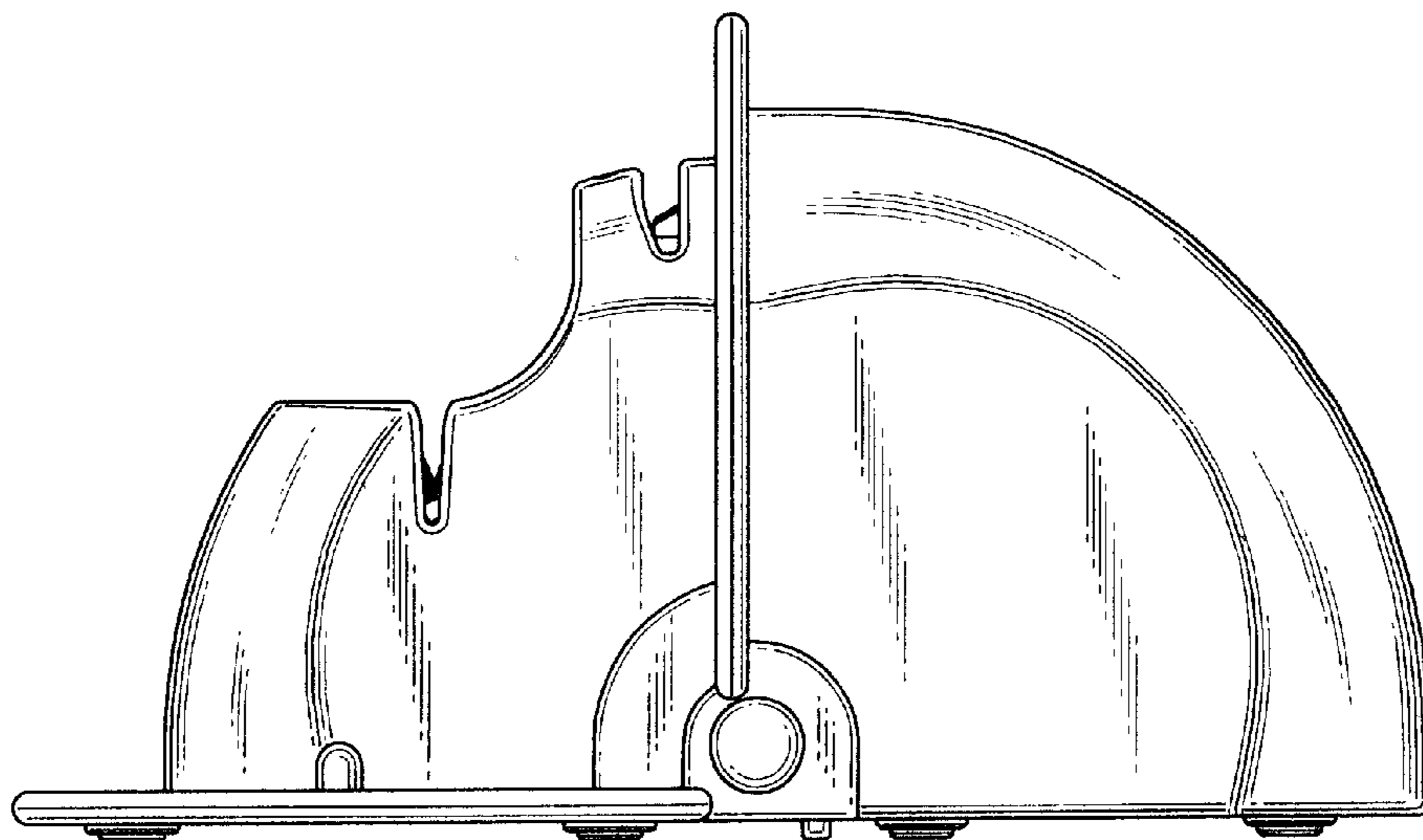

Fig. 3

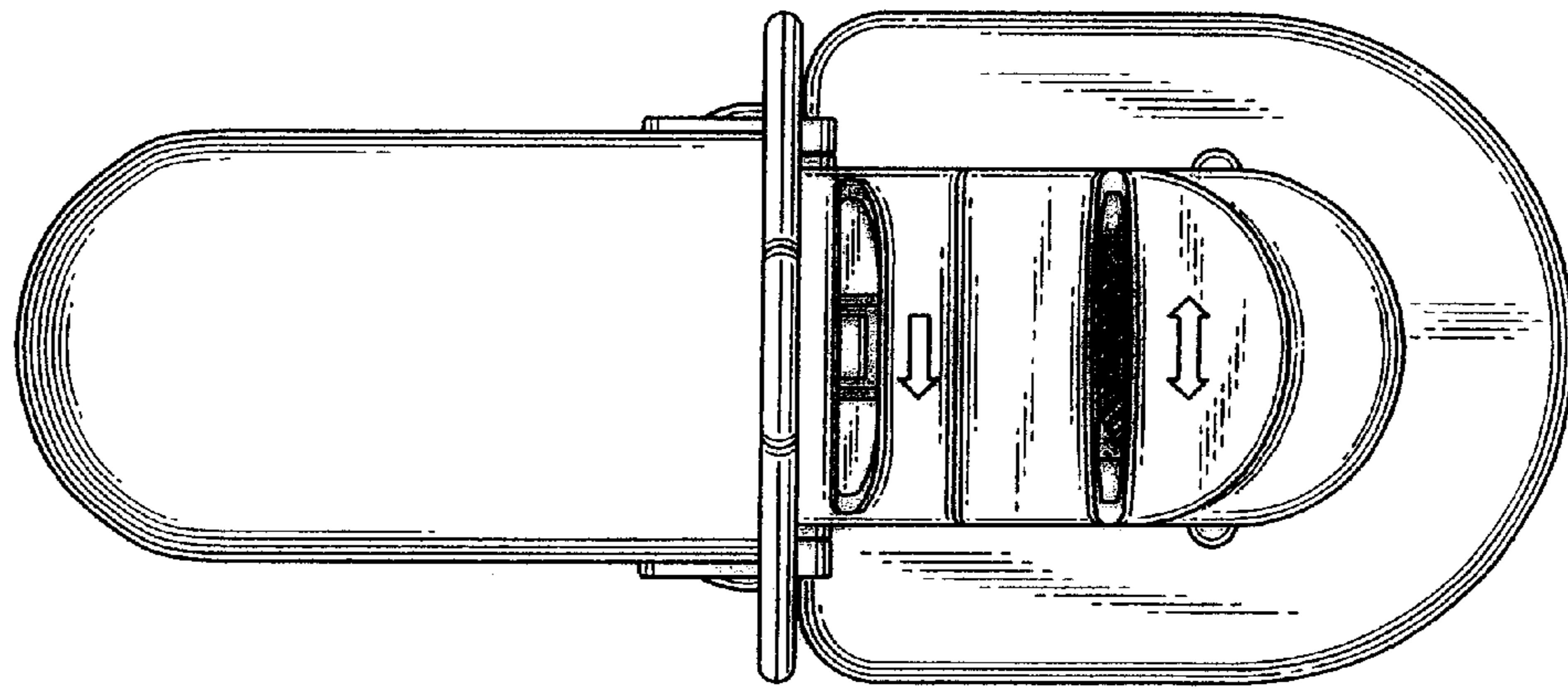

Fig. 4

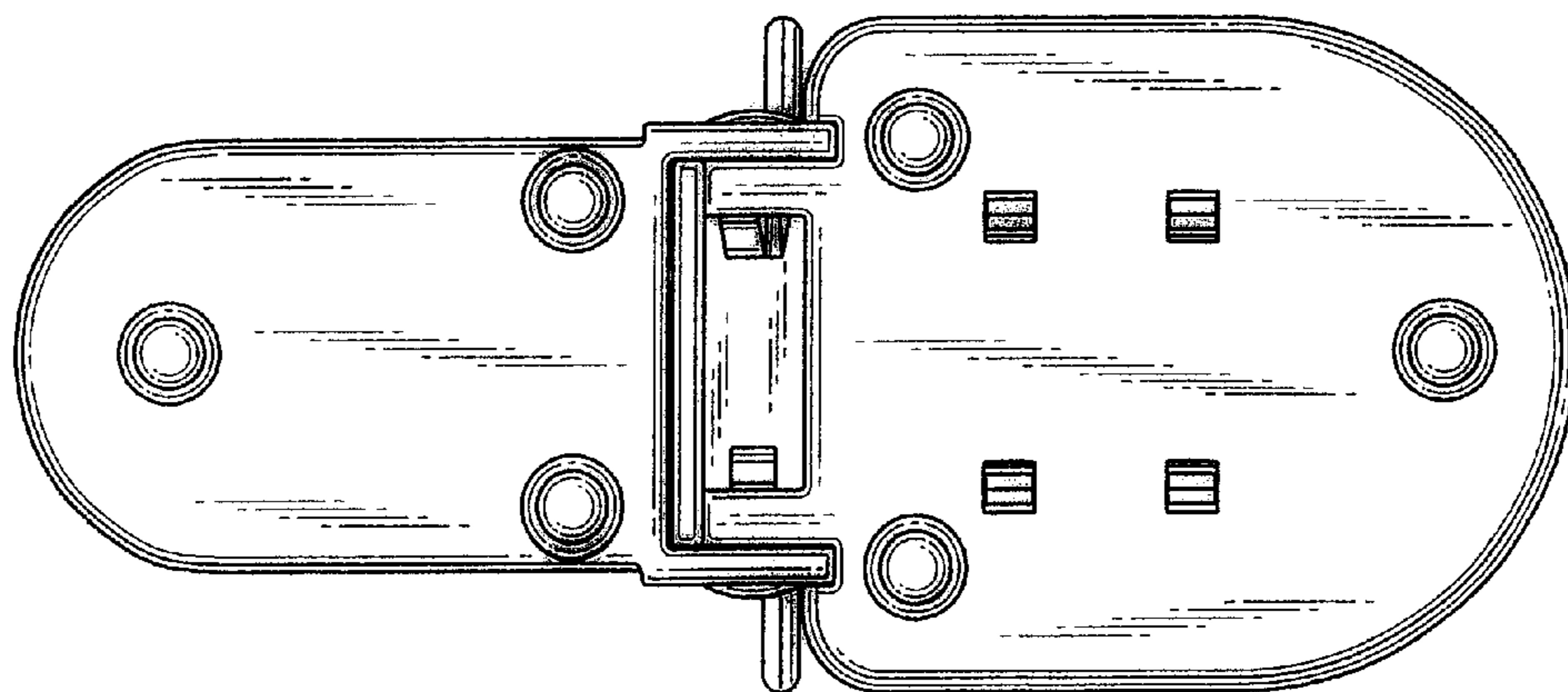

Fig. 5

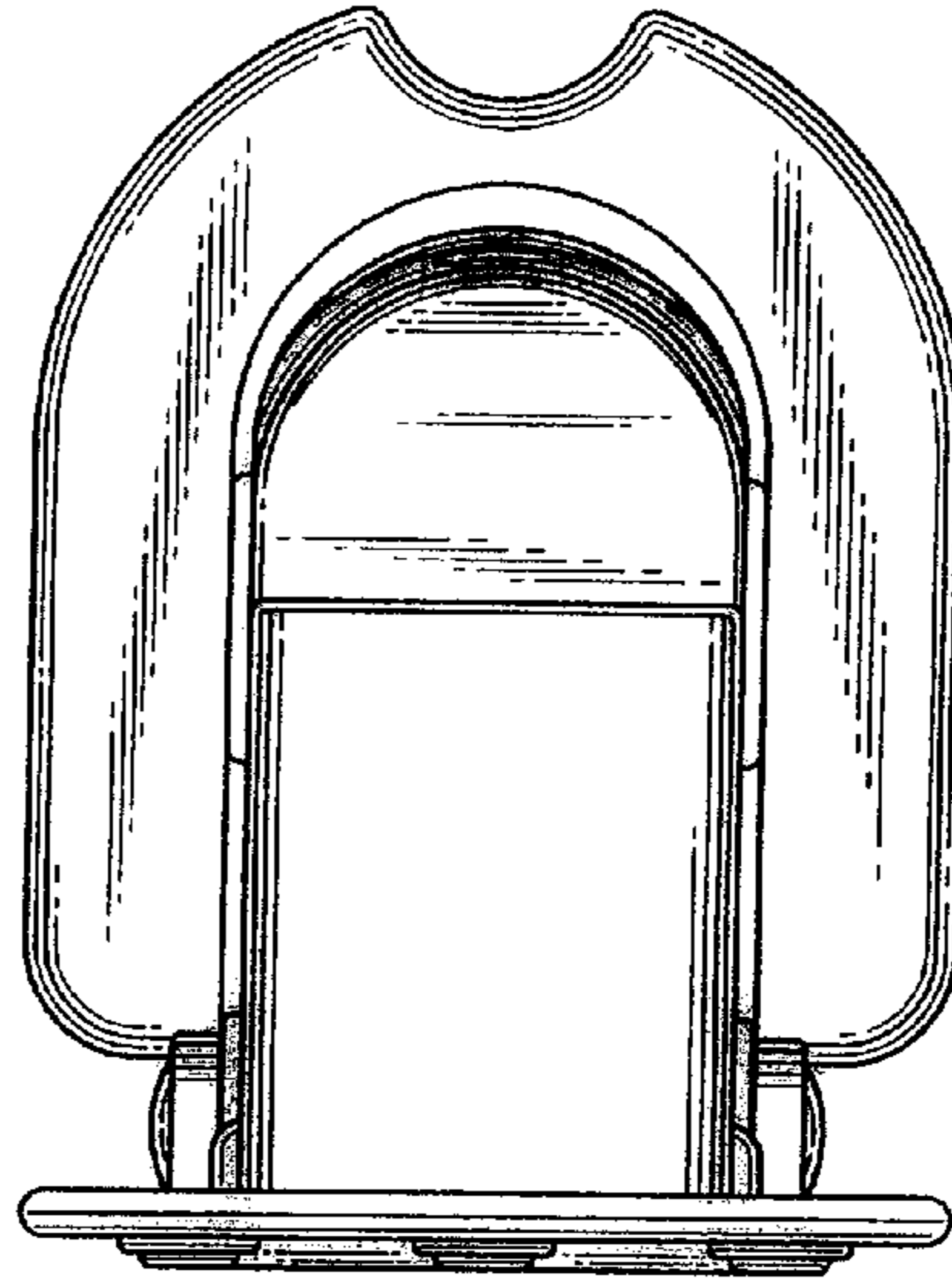

Fig. 6

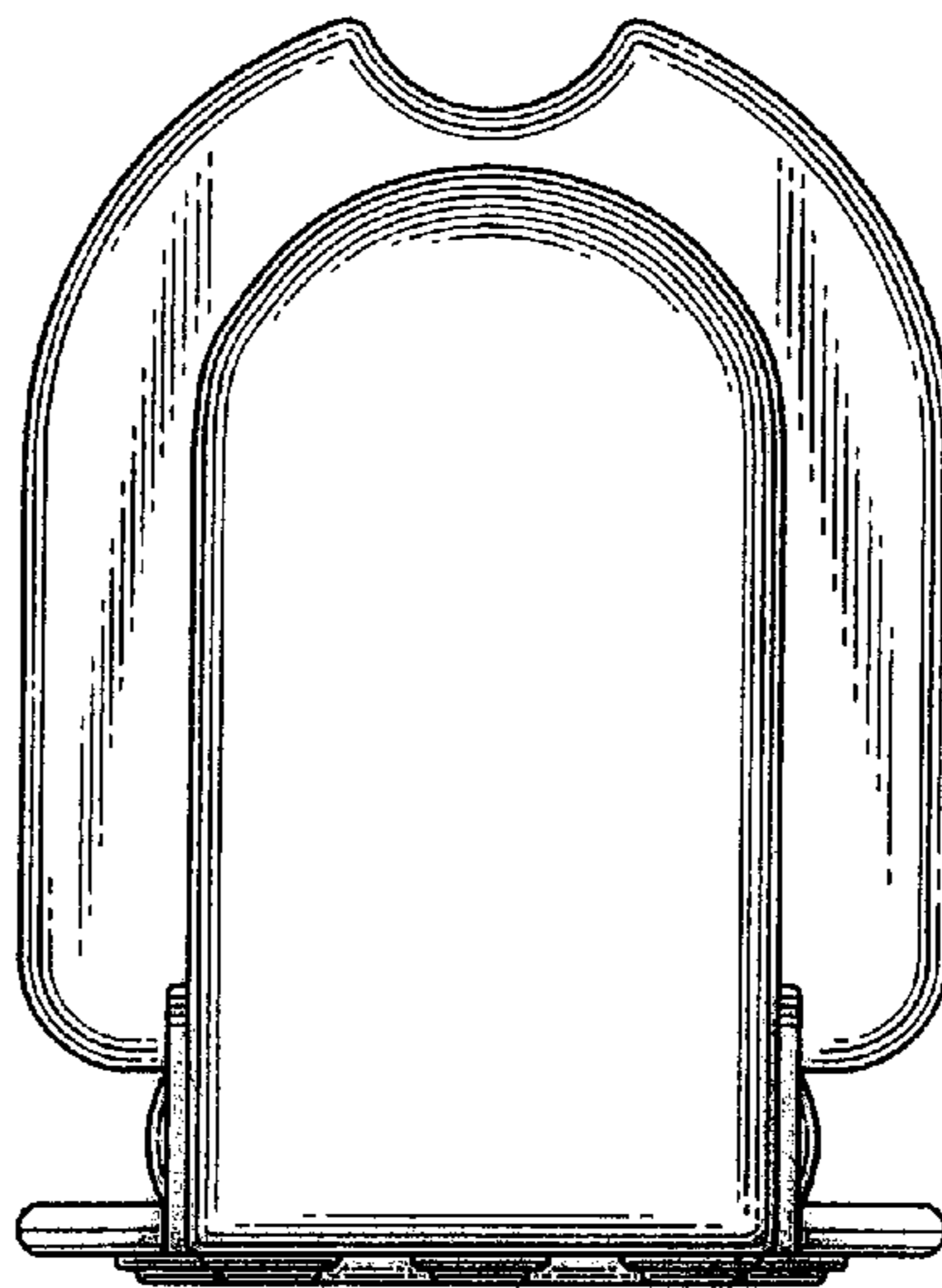

Fig. 7

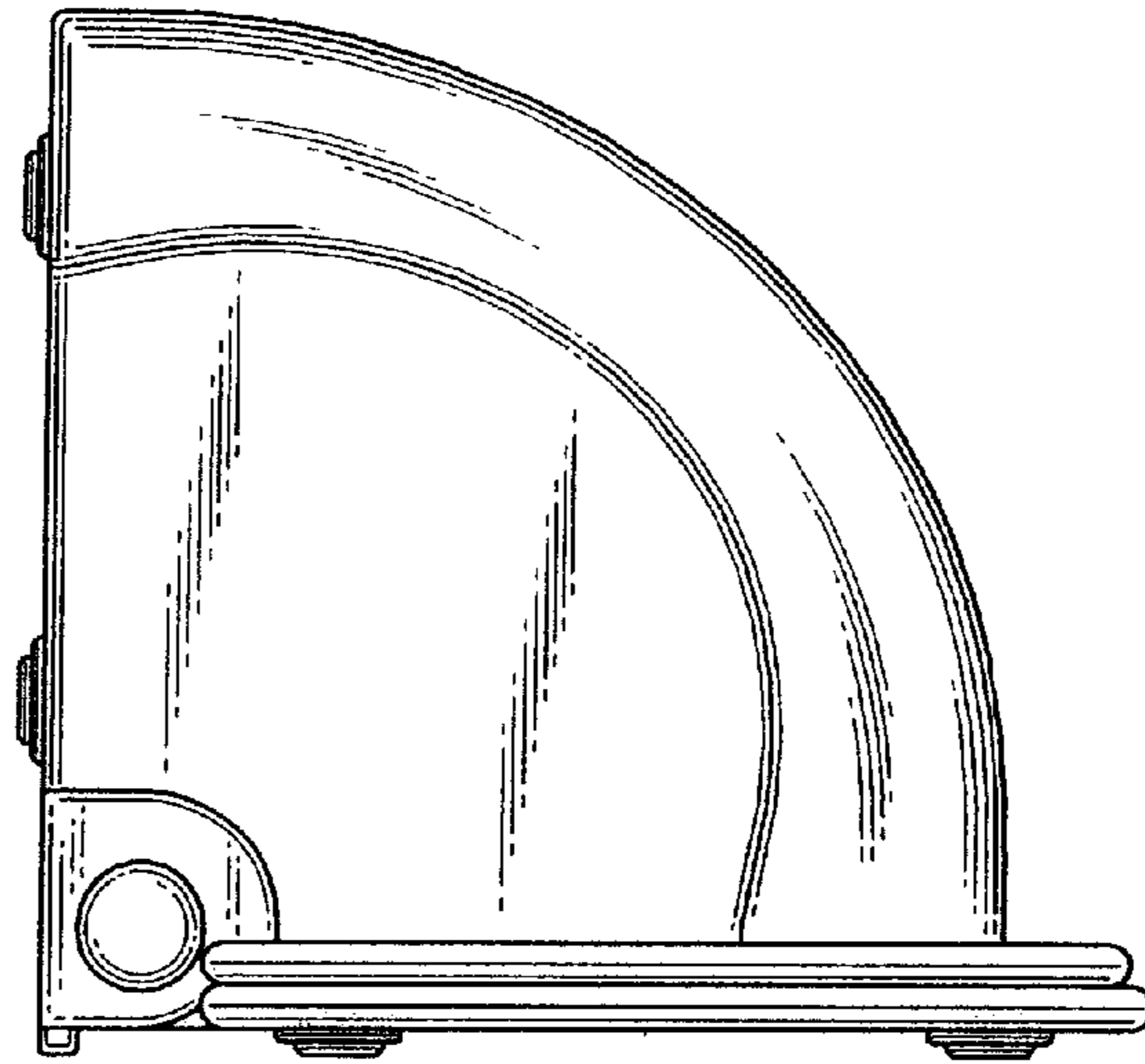

Fig. 8

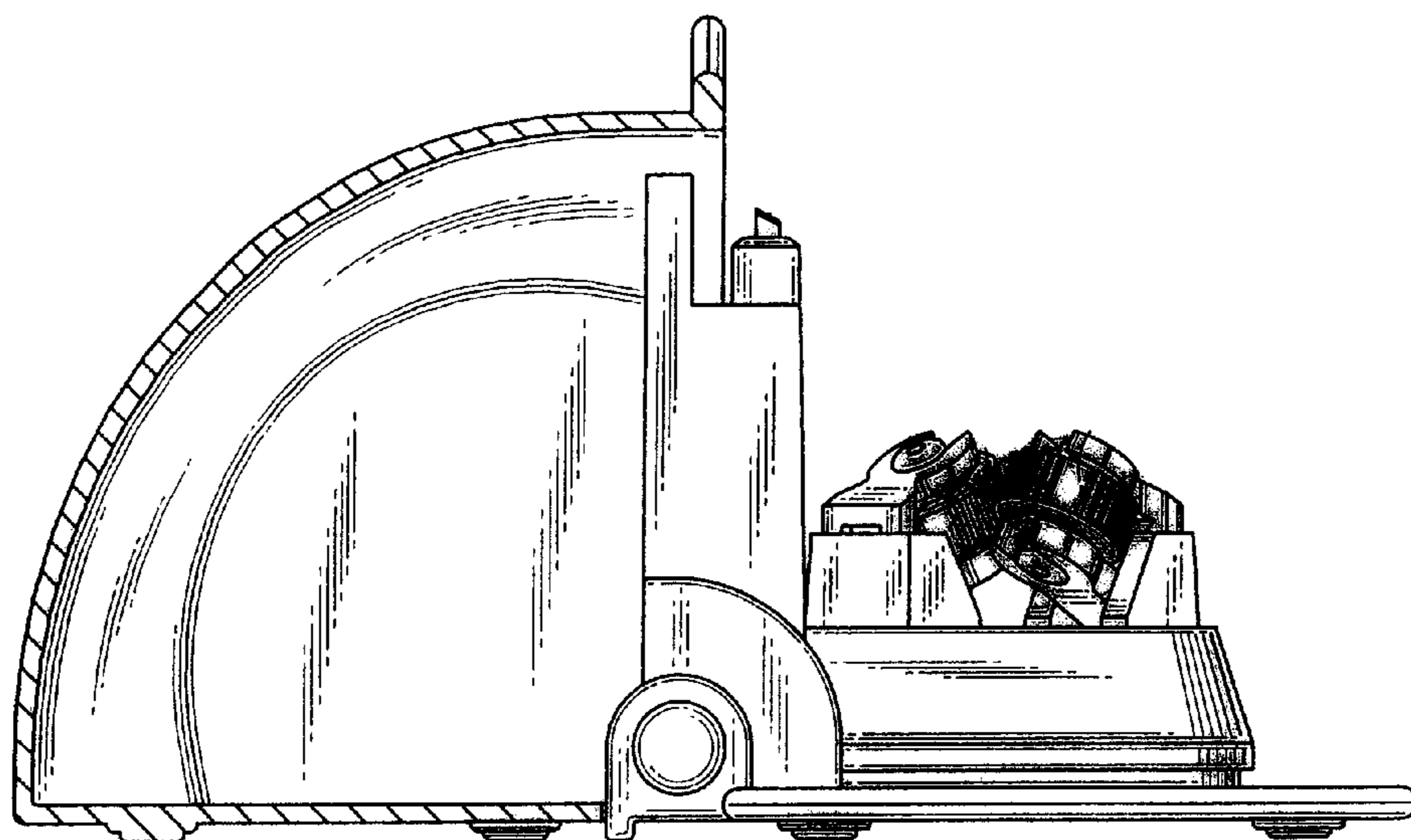

Fig. 9

