



US00D537584S

(12) **United States Design Patent**  
**Greene et al.**

(10) **Patent No.:** **US D537,584 S**

(45) **Date of Patent:** **\*\* Feb. 27, 2007**

(54) **COMPACT VACUUM CLEANER**

(75) Inventors: **Mason Greene**, Auburn, AL (US);  
**Mark Rosenzweig**, Chestnut Hill, MA  
(US)

(73) Assignee: **Euro-Pro Operating, LLC**, West  
Newton, MA (US)

(\*\*) **Term:** **14 Years**

(21) Appl. No.: **29/202,436**

(22) Filed: **Mar. 30, 2004**

(51) **LOC (8) Cl.** ..... **15-05**

(52) **U.S. Cl.** ..... **D32/22**

(58) **Field of Classification Search** ..... D32/17-18,  
D32/21-22, 25, 30-34; 15/320-321, 323,  
15/327.1, 335, 344, 347, 350-353, 361, 329,  
15/410, 412; 55/459.1-459.2, 449, DIG. 3,  
55/426, 337, 345, 429, 467, 472; 95/271;  
210/787, 806, 512.1, 512.2

See application file for complete search history.

(56) **References Cited**

**U.S. PATENT DOCUMENTS**

- D309,203 S 7/1990 Goodrich
- D343,707 S 1/1994 Dyson
- D375,820 S \* 11/1996 Piccaluga et al. .... D32/22
- D417,533 S 12/1999 Burchard et al.

- 6,193,787 B1 \* 2/2001 Dyson et al. .... 95/271
- D439,379 S \* 3/2001 Gammack et al. .... D32/22
- D462,813 S 9/2002 Nakano et al.
- D462,814 S 9/2002 Sugimoto
- D473,981 S \* 4/2003 Wareham ..... D32/22
- D475,820 S \* 6/2003 Dyson et al. .... D32/22
- 6,735,818 B2 \* 5/2004 Hamada et al. .... 15/410
- D494,719 S \* 8/2004 Rosenzweig et al. .... D32/31
- 2002/0108208 A1 \* 8/2002 Hamada et al. .... 15/352
- 2003/0188396 A1 10/2003 Hitzelberger et al.

\* cited by examiner

*Primary Examiner*—Ruth McInroy

(74) *Attorney, Agent, or Firm*—Greenberg Traurig, LLP;  
Michael I. Wolfson; Sylvia Tan

(57) **CLAIM**

The ornamental design for a compact vacuum cleaner, as shown and described.

**DESCRIPTION**

FIG. 1 is a top, front and left side perspective view of a compact vacuum cleaner showing our new design; FIG. 2 is a front perspective view thereof; FIG. 3 is a right side perspective view thereof; FIG. 4 is a left side perspective view thereof; FIG. 5 is a rear perspective view thereof; FIG. 6 is a top perspective view thereof; and, FIG. 7 is a bottom perspective view thereof.

**1 Claim, 6 Drawing Sheets**

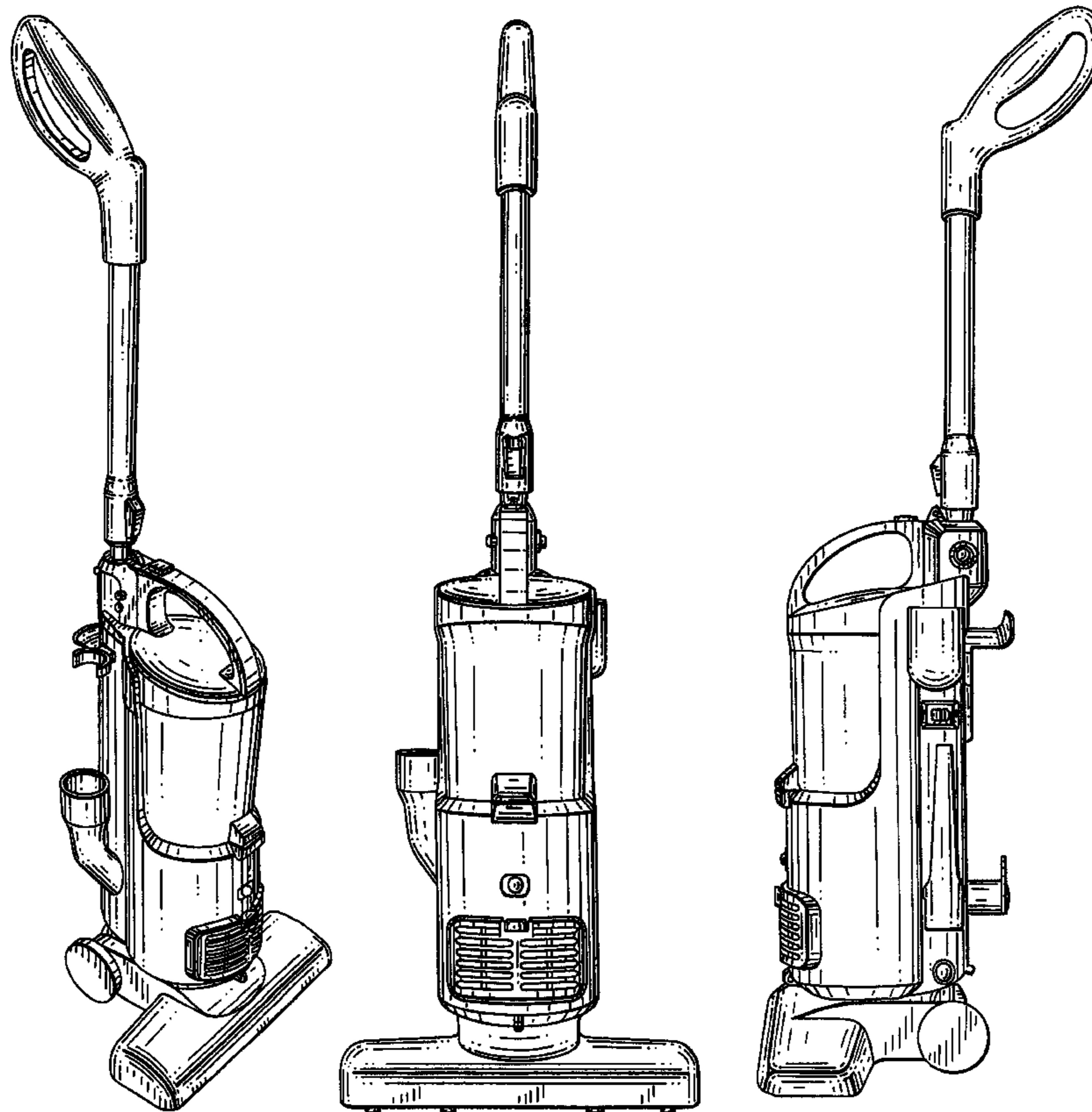

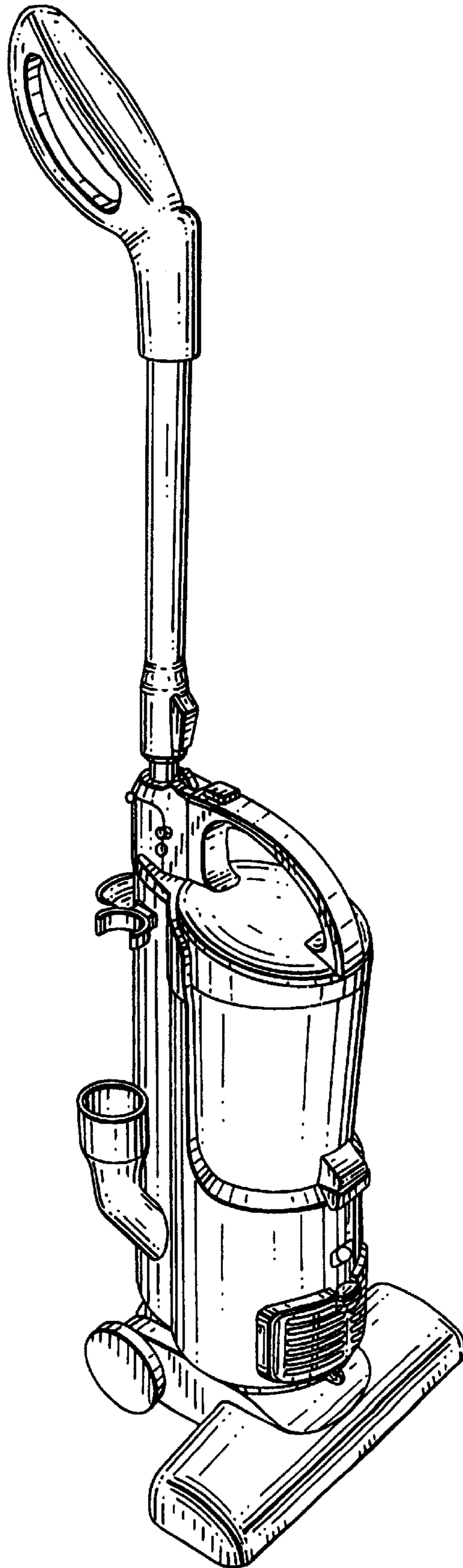

FIG. 1

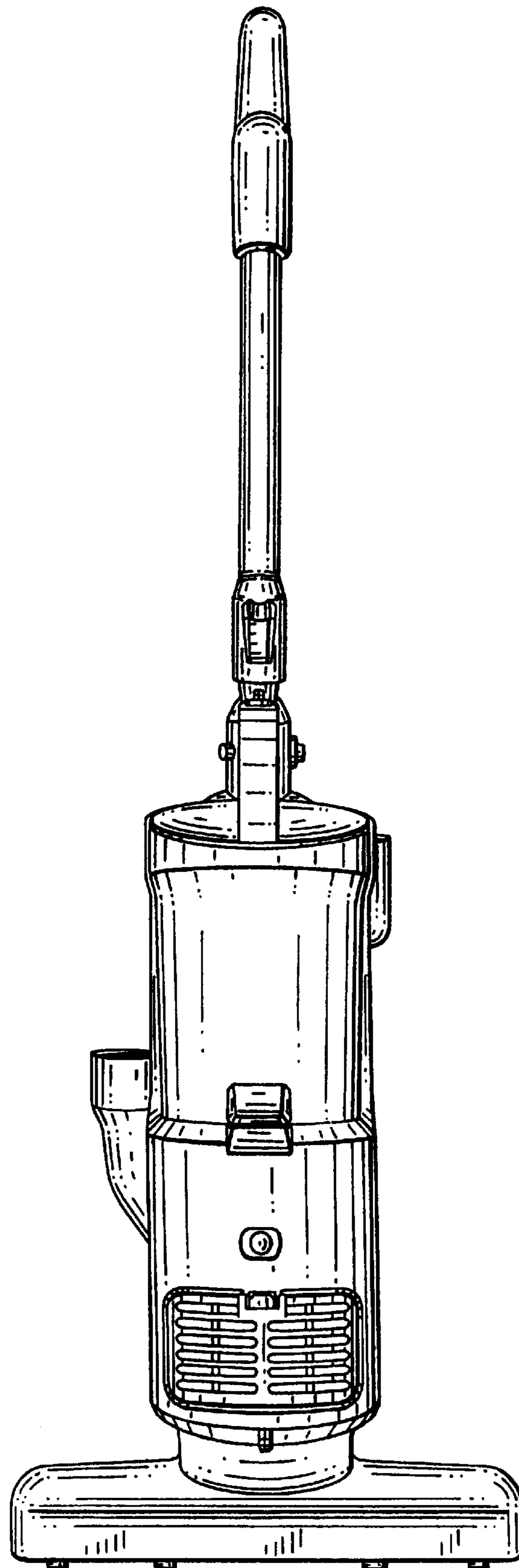

FIG. 2

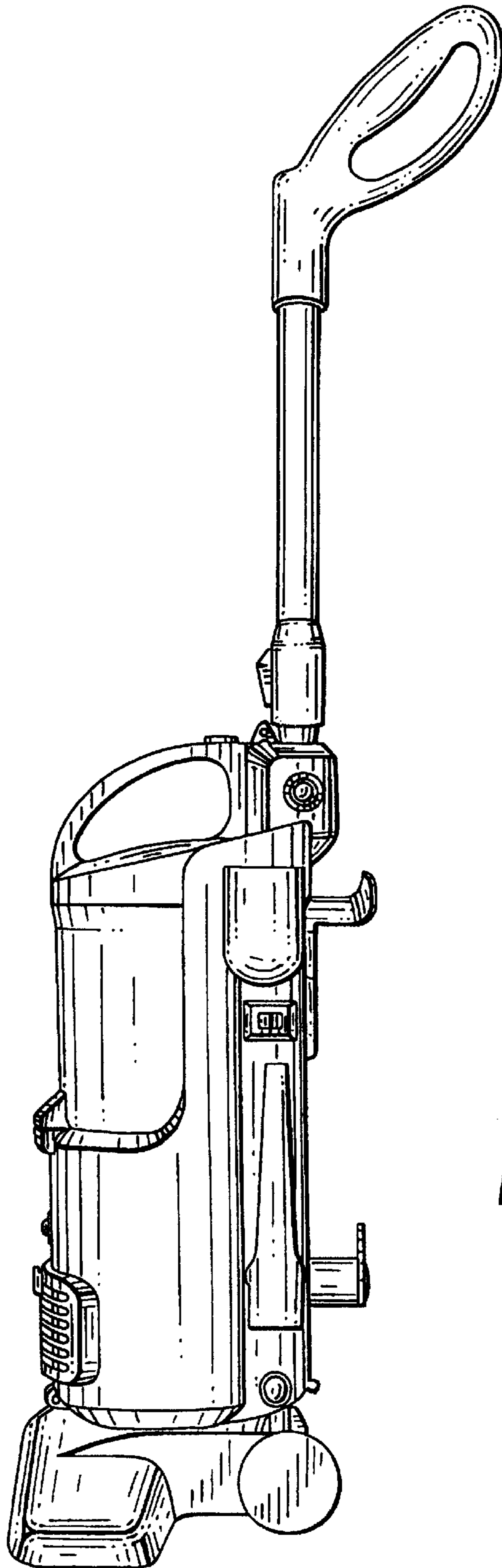

FIG. 3

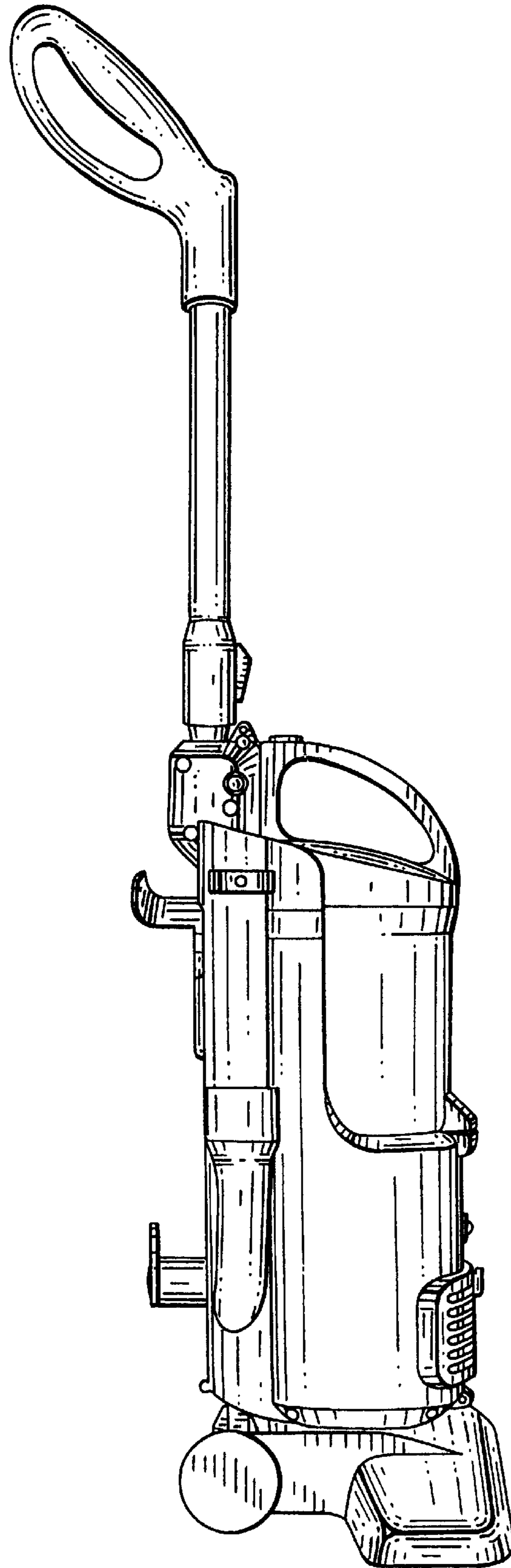

FIG. 4

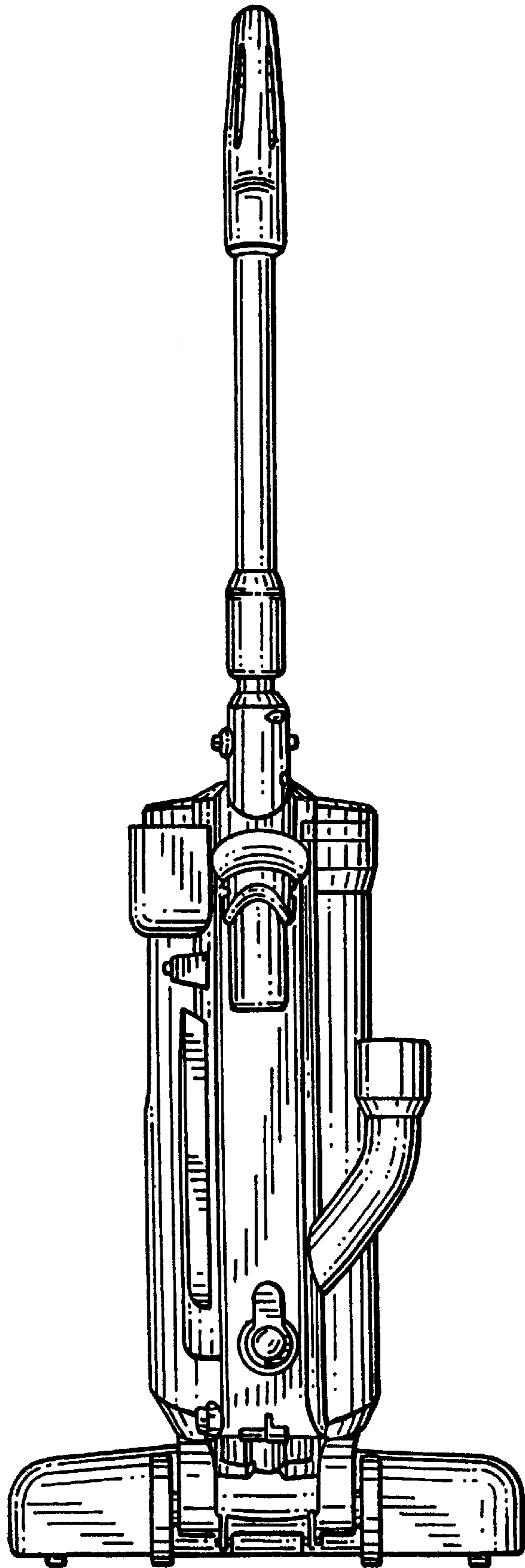

FIG. 5

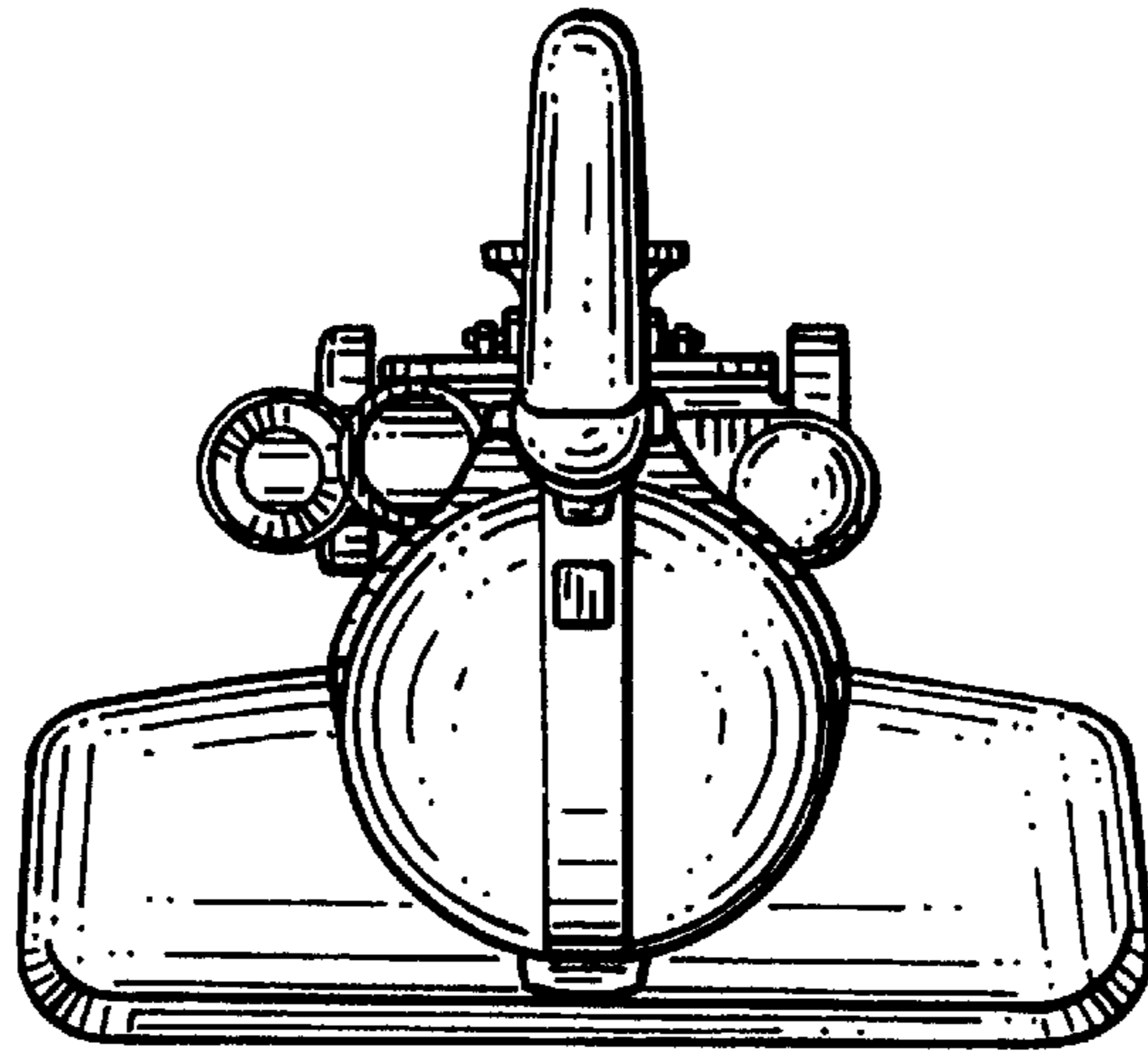

FIG. 6

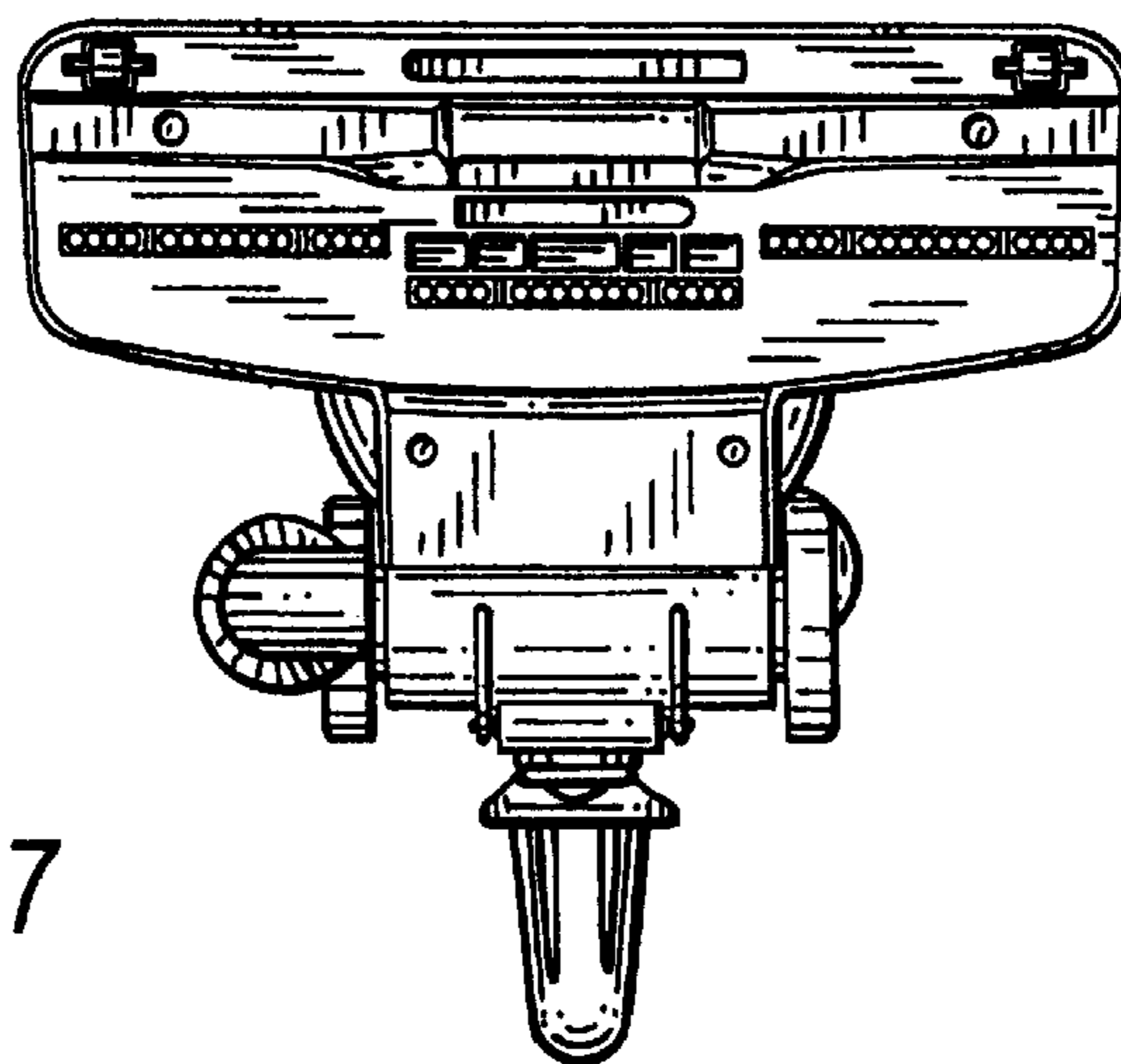

FIG. 7