

US00D537537S

(12) **United States Design Patent** (10) **Patent No.:** **US D537,537 S**
Antonic (45) **Date of Patent:** **** Feb. 27, 2007**

(54) **CONSTRUCTION BEAM**

(76) Inventor: **James P. Antonic**, 9111 Southmont
Cove, #406, Ft. Myers, FL (US) 33908
(**) Term: **14 Years**
(21) Appl. No.: **29/233,442**
(22) Filed: **Jul. 1, 2005**

Related U.S. Application Data

(63) Continuation of application No. 11/116,769, filed on Apr. 28,
2005.
(51) **LOC (8) Cl.** **25-01**
(52) **U.S. Cl.** **D25/122**
(58) **Field of Classification Search** D25/119,
D25/122; 52/281, 282.2, 282.3, 460, 461,
52/479, 481.1, 220.1
See application file for complete search history.

(56) **References Cited**

U.S. PATENT DOCUMENTS

3,184,013	A	*	5/1965	Pavlecka	52/275
4,660,339	A	*	4/1987	Paz	52/238.1
5,070,667	A	*	12/1991	Schulte	52/241
5,644,888	A		7/1997	Johnson		
5,735,090	A	*	4/1998	Papke	52/220.2
5,848,512	A	*	12/1998	Conn	52/729.1
D407,828	S	*	4/1999	Hart	D25/122
6,003,279	A		12/1999	Schneider		
6,092,340	A		7/2000	Simmons		
6,272,796	B1		8/2001	Metzler		
6,276,094	B1		8/2001	Hays		
6,314,704	B1		11/2001	Bryant		
6,427,403	B1		8/2002	Tambakis		
6,438,903	B1		8/2002	Weiss		
D473,955	S	*	4/2003	Gregori	D25/122
6,581,337	B1		6/2003	Skov et al.		
6,754,999	B1		6/2004	Urbanczk		
2002/0069600	A1		6/2002	Bryant		
2002/0092245	A1		7/2002	Floyd et al.		
2003/0089066	A1		5/2003	Nelson		

OTHER PUBLICATIONS

U.S. Appl. No. 29/233,444, filed Jul. 1, 2005, Antonic.
U.S. Appl. No. 29/233,443, filed Jul. 1, 2005, Antonic.
U.S. Appl. No. 29/233,441, filed Jul. 1, 2005, Antonic.
* cited by examiner

Primary Examiner—Doris Clark
(74) *Attorney, Agent, or Firm*—Laura G. Barrow

(57) **CLAIM**

I claim the ornamental design of a construction beam, as shown and described.

DESCRIPTION

FIG. 1 is a perspective view of a first embodiment of the construction beam showing my new design, the construction beam being of indeterminate length.
FIG. 2 is a front elevation of the design shown in FIG. 1. The front and rear views of this first embodiment of the construction beam are identical.
FIG. 3 is a side elevation of the construction beam shown in FIG. 1. The right and left sides of this first embodiment of the construction beam are identical.
FIG. 4 is a top plan view of the construction beam shown in FIG. 1.
FIG. 5 is a bottom plan view of the construction beam shown in FIG. 1.
FIG. 6 is a perspective view of a second embodiment of the construction beam showing my new design, the construction beam being of indeterminate length.
FIG. 7 is a front elevation of the design shown in FIG. 6. The front and rear views of this second embodiment of the construction beam are identical.
FIG. 8 is a side elevation view of the construction beam shown in FIG. 6. The right and left sides of this second embodiment of the construction beam are identical.
FIG. 9 is a top plan view of the construction beam shown in FIG. 6; and,
FIG. 10 is a bottom plan view of the construction beam shown in FIG. 6.

1 Claim, 6 Drawing Sheets

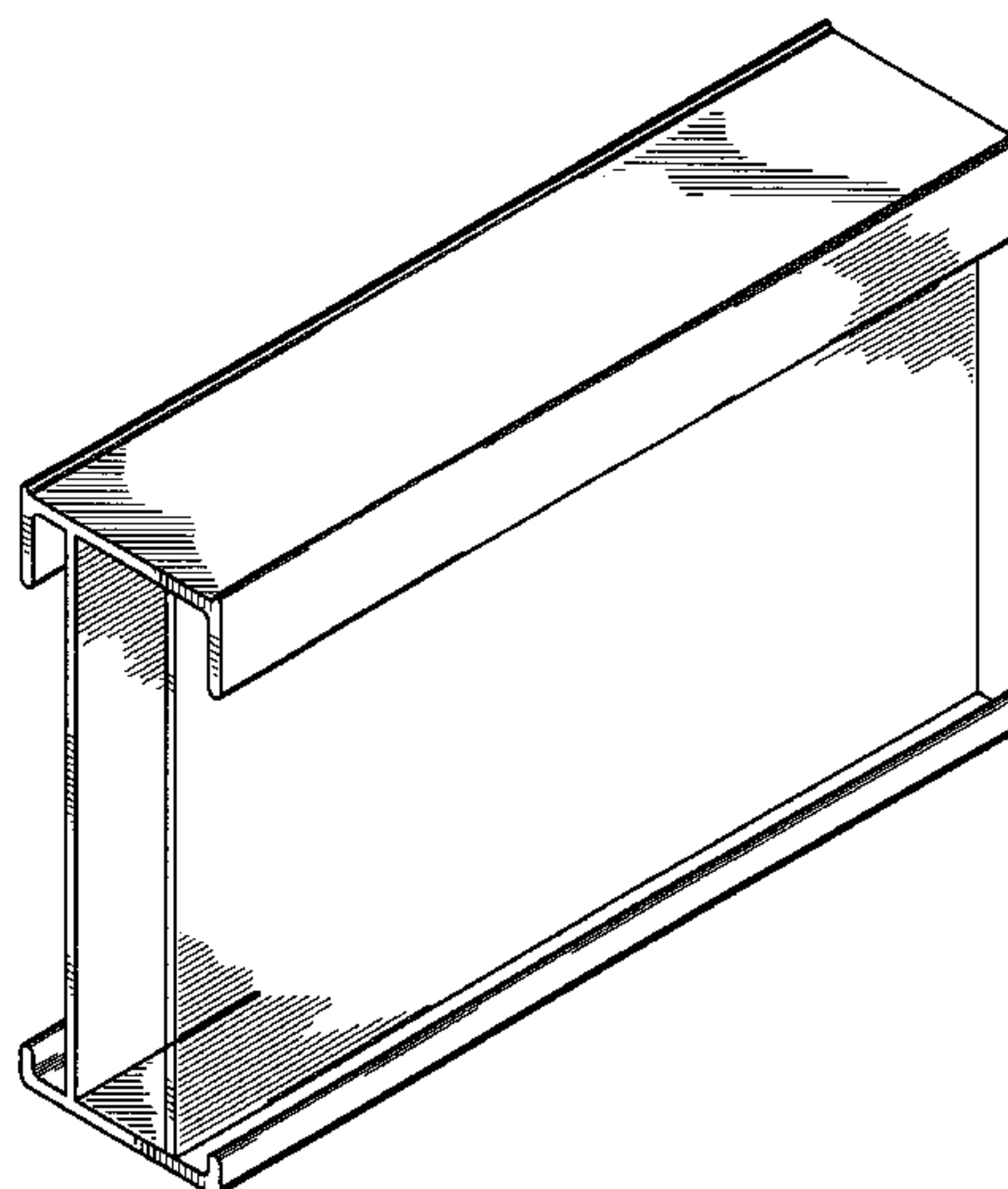

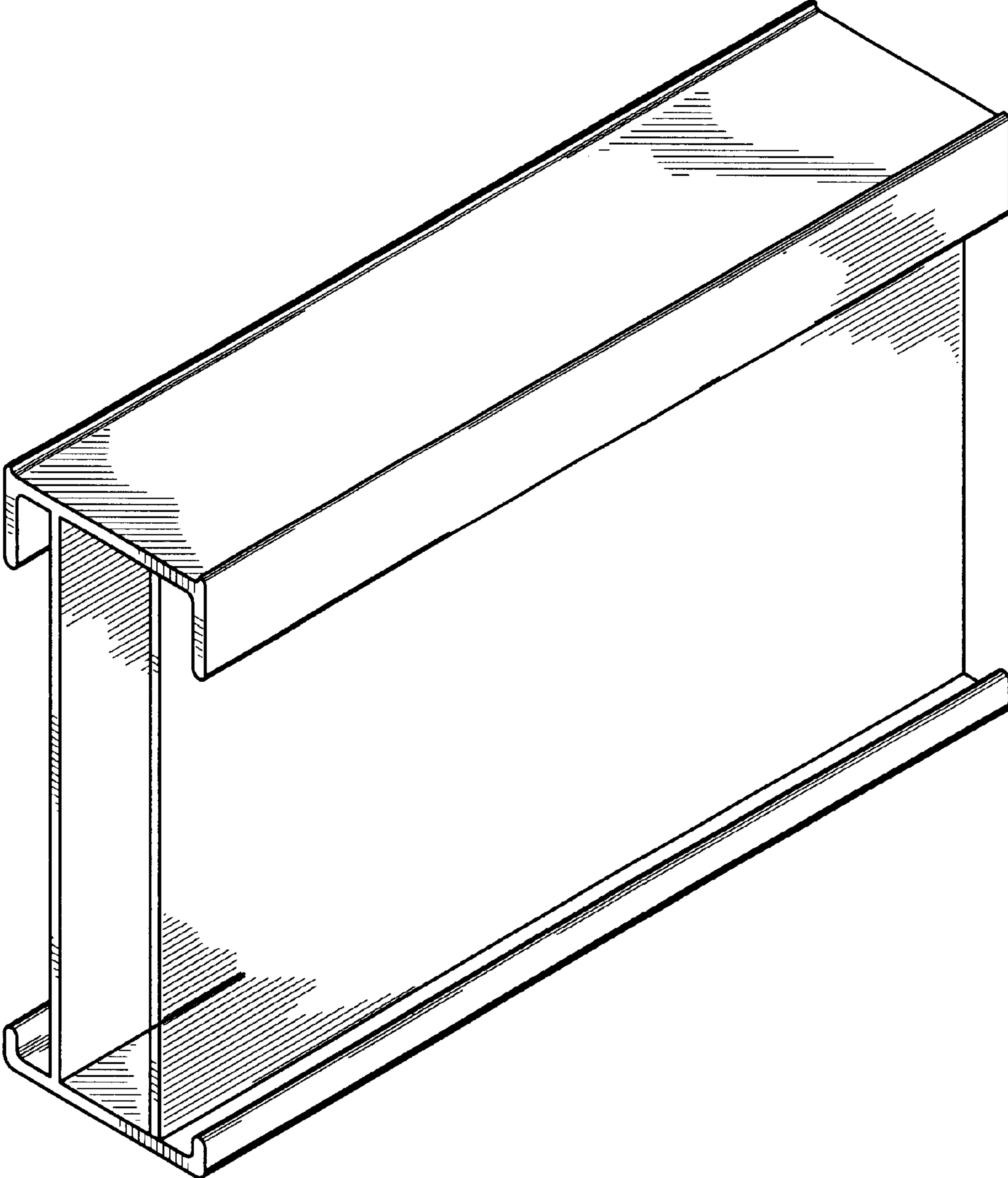

Fig. 1

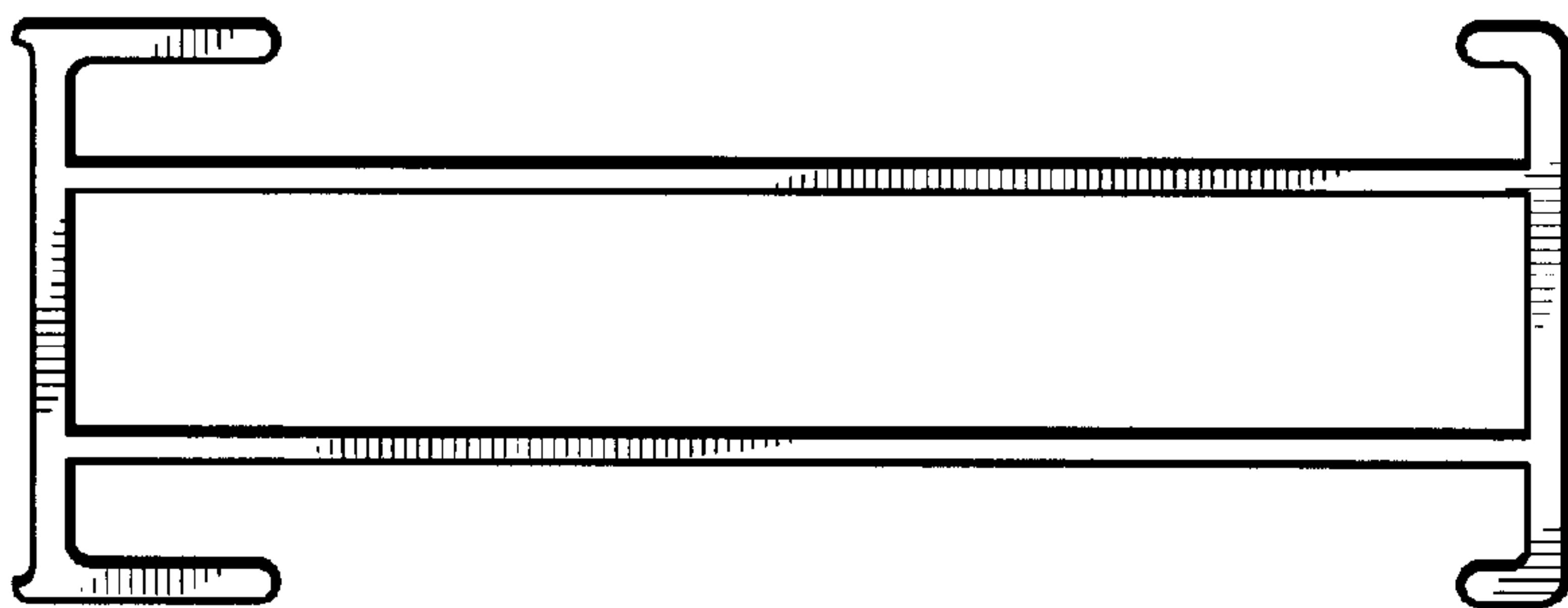

Fig. 2

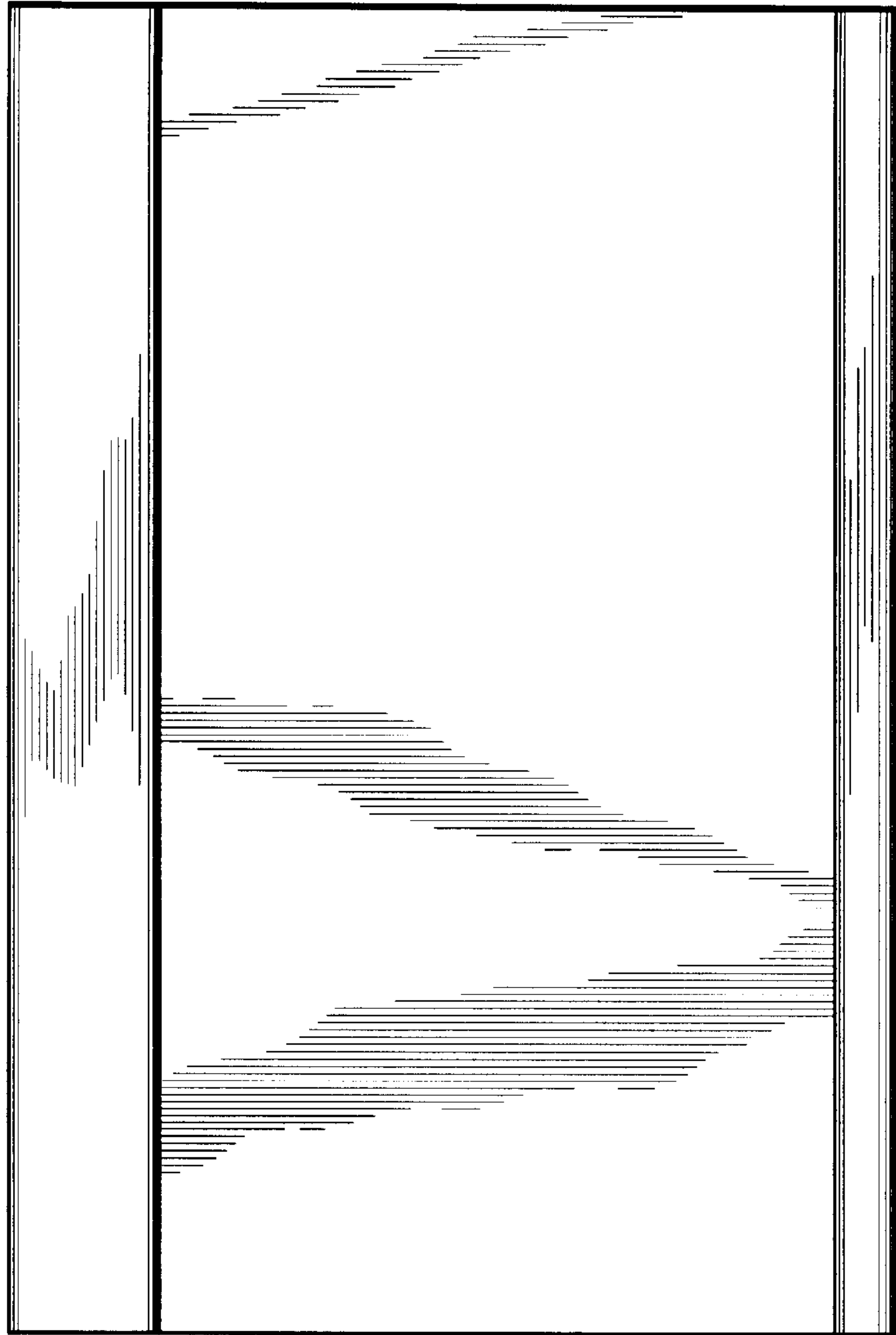

Fig. 3

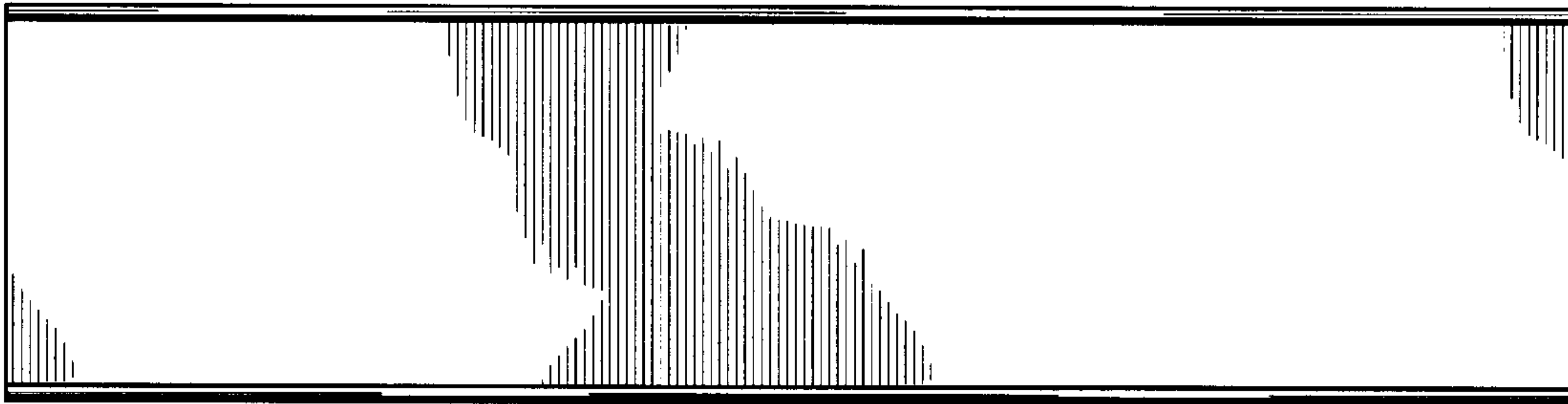

Fig. 4

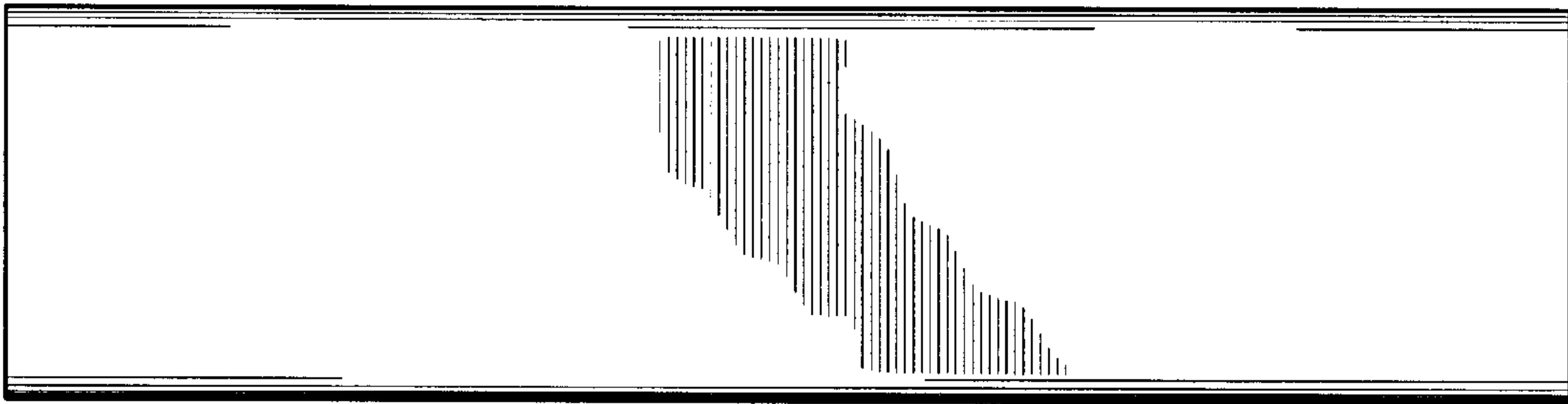

Fig. 5

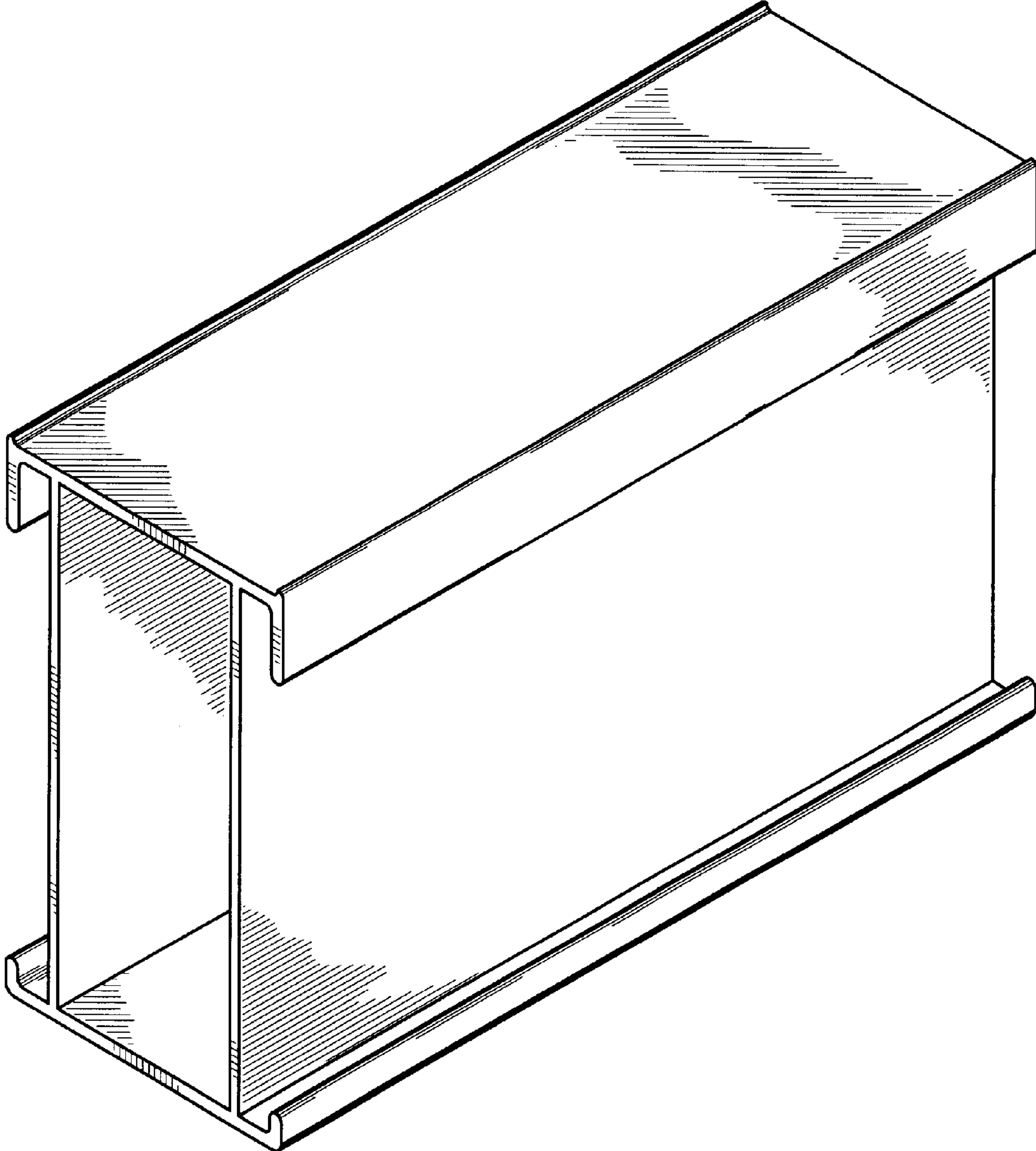

Fig. 6

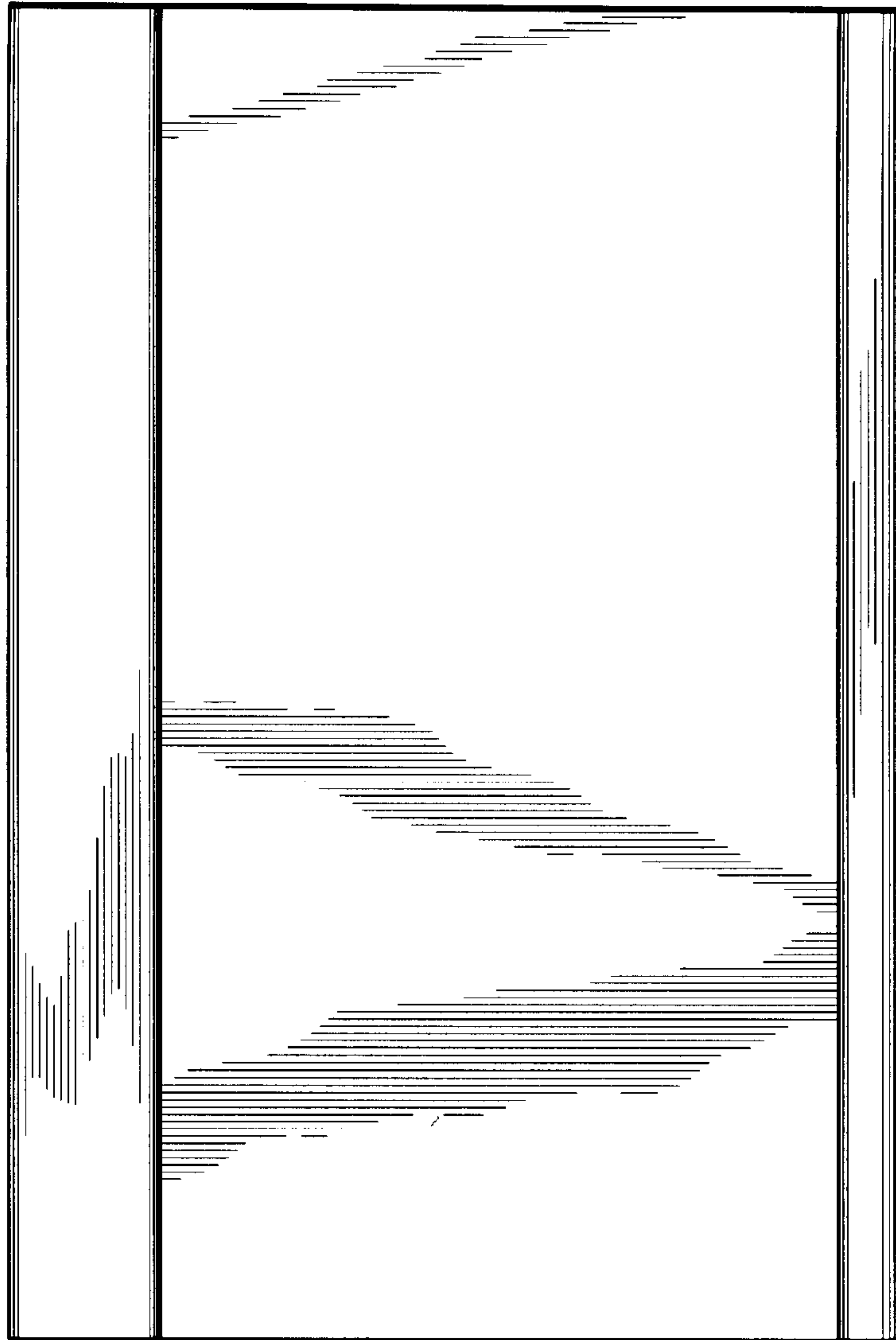

Fig. 7

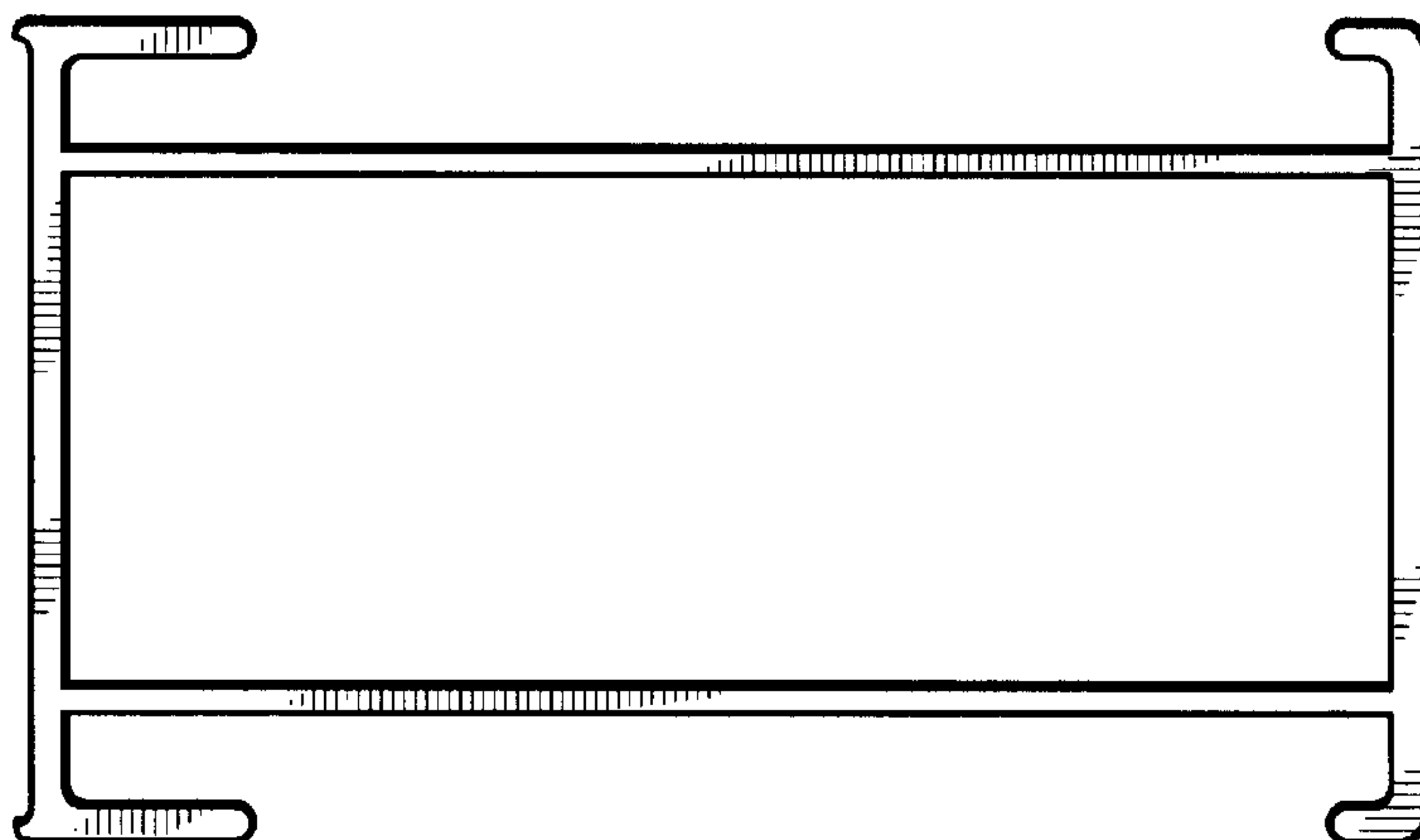

Fig. 8

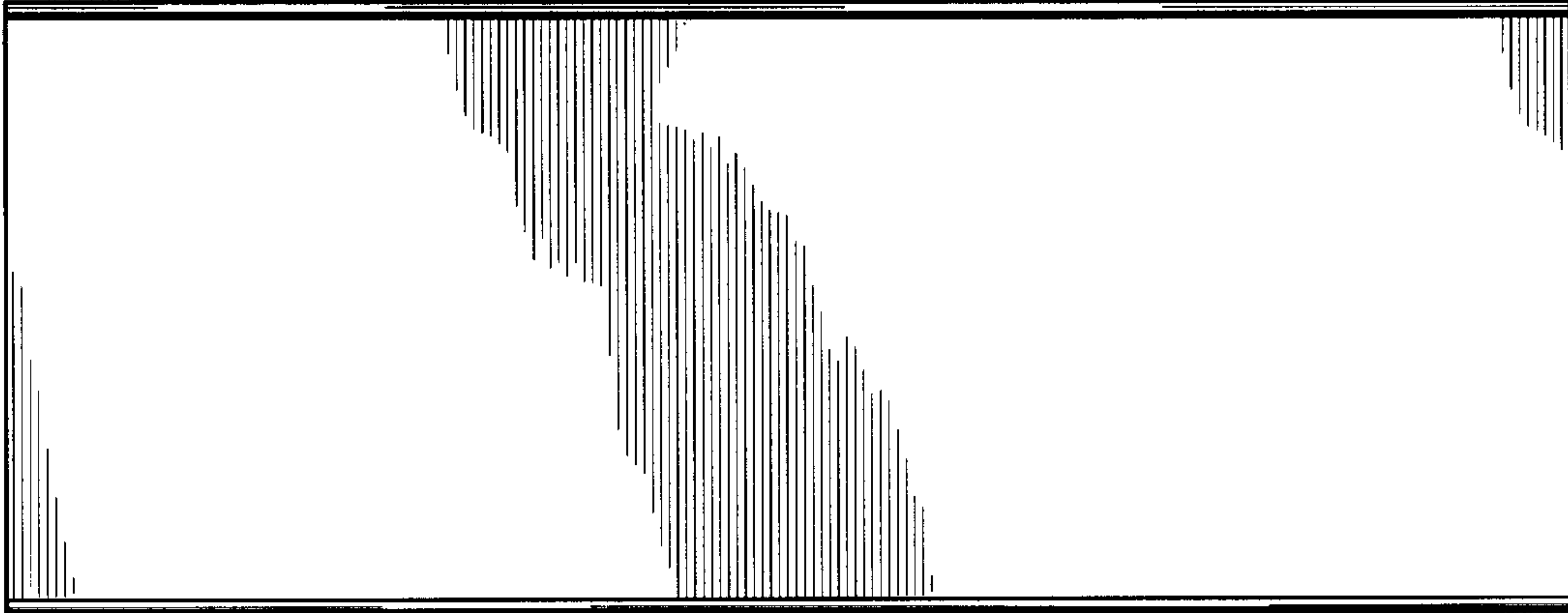

Fig. 9

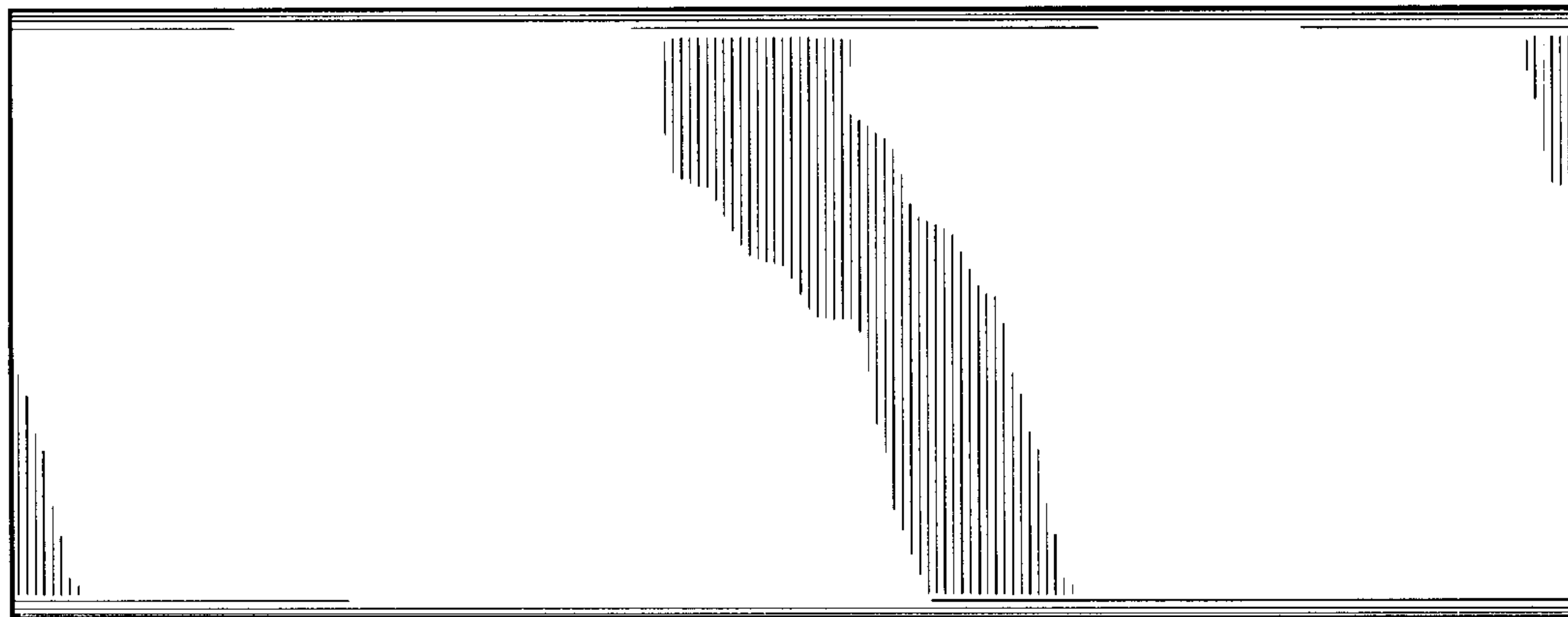

Fig. 10