



US00D537396S

(12) **United States Design Patent** (10) **Patent No.:** **US D537,396 S**
Drew et al. (45) **Date of Patent:** **** Feb. 27, 2007**

(54) **MUFFLER**

(75) Inventors: **Christopher J. Drew**, New Berlin, WI (US); **Charles Lasky**, Grafton, WI (US); **Paul A. Leech**, Fox Point, WI (US); **John P. McDonald**, New Berlin, WI (US); **Brian P. Saiia**, Milwaukee, WI (US); **John R. Schneiker**, Muskego, WI (US); **Kipp K. Stevens**, Fox Point, WI (US); **Christina E. Wisler**, Waukesha, WI (US)

(73) Assignee: **Briggs & Stratton Corporation**, Wauwatosa, WI (US)

(**) Term: **14 Years**

(21) Appl. No.: **29/232,000**

(22) Filed: **Jun. 13, 2005**

(51) **LOC (8) Cl.** **12-16**

(52) **U.S. Cl.** **D12/194**

(58) **Field of Classification Search** D12/194;
D15/1-5; 60/317; 29/890, 890.08; 181/227-229,
181/232, 240, 243-245, 248-252, 256-257,
181/264, 268, 272-274, 284
See application file for complete search history.

(56) **References Cited**

U.S. PATENT DOCUMENTS

D394,236 S	*	5/1998	Verlengiere	D12/194
D446,489 S	*	8/2001	Park	D12/194
D447,456 S	*	9/2001	Larson et al.	D12/194
D452,672 S	*	1/2002	Kim	D12/194
D467,846 S	*	12/2002	McGee	D12/194

OTHER PUBLICATIONS

KAWASAKI, Four-Cycle Engines, Kawasaki FJ180V, website, http://www.kawpowr.com/4cycle/fj180v_specs.html, 1 page, Feb. 2, 2005.

KAWASAKI, Four-Cycle Engines, Kawasaki FC290v, website, http://www.kawpowr.com/4cycle/fc290v_specs.html, 1 page, Feb. 2, 2005.

KAWASAKI, Four-Cycle Engines, Kawasaki FH721D, website, http://www.kawpowr.com/4cycle/fh721d_specs.html, 1 page, Feb. 2, 2005.

KAWASAKI, Four-Cycle Engines, Kawasaki FH601D, website, http://www.kawpowr.com/4cycle/fh601d_specs.html, 1 page, Feb. 2, 2005.

KAWASAKI, Four-Cycle Engines Kawasaki FH601V, website, http://www.kawpowr.com/4cycle/fh601v_specs.html, 1 page, Feb. 2, 2005.

KAWASAKI, Four-Cycle Engines, Kawasaki FH500V, website, http://www.kawpowr.com/4cycle/fh500v_specs.html, 1 page, Feb. 2, 2005.

KAWASAKI, Four-Cycle Engines, Kawasaki FC150V, website, http://www.kawpowr.com/4cycle/fc150v_specs.html, 1 page, Feb. 2, 2005.

KAWASAKI, Four-Cycle Engines, Kawasaki FH721V, website, http://www.kawpowr.com/4cycle/fh721v_specs.html, 1 page, Feb. 2, 2005.

Tecumseh Power Company; Walk-Behind Engines & Transmissions Horsepower Range: 3.5-7.0, website <http://www.tecumsehpower.com/Products/WalkBehind/index.php>, 1 page, Feb. 2, 2005.

(Continued)

Primary Examiner—Ian Simmons

Assistant Examiner—Maurice Stevens

(74) *Attorney, Agent, or Firm*—Michael Best & Friedrich LLP

(57) **CLAIM**

The ornamental design for a muffler, as shown and described.

DESCRIPTION

FIG. 1 is a front perspective view of a muffler according to the invention.

FIG. 2 is a top view of the muffler of FIG. 1.

FIG. 3 is a bottom view of the muffler of FIG. 1.

FIG. 4 is a front view of the muffler of FIG. 1.

FIG. 5 is a rear view of the muffler of FIG. 1.

FIG. 6 is a left side view of the muffler of FIG. 1; and,

FIG. 7 is a right side view of the muffler of FIG. 1.

1 Claim, 5 Drawing Sheets

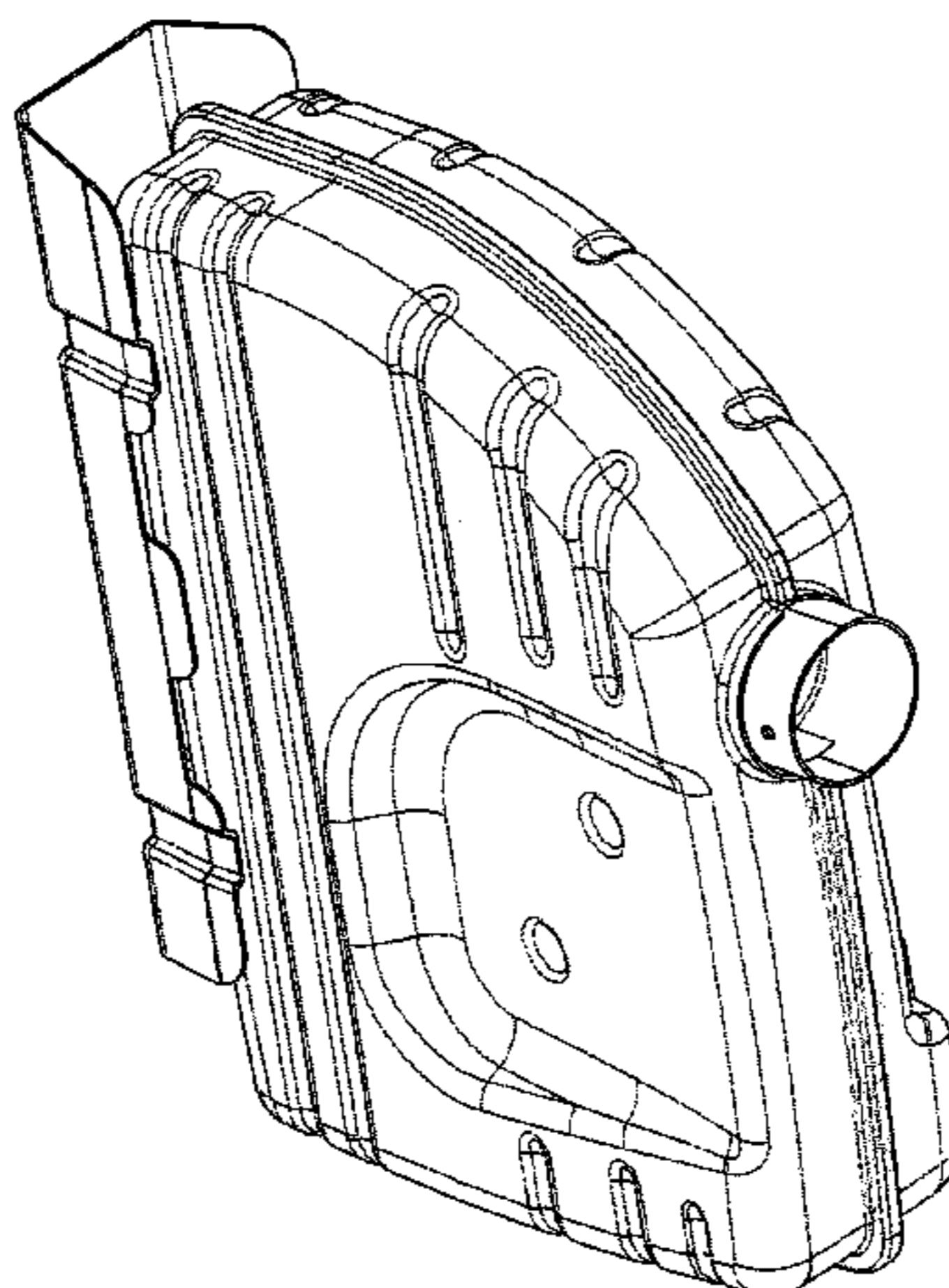

OTHER PUBLICATIONS

Kohler Co. Engine Division; Kohler Engines Born to Run Owner's Manual, Command 11–16 HP Vertical Crankshaft; Cover Sheet, Revised Sep. 1999, Kohler Co. Engine Division, Kohler, Wisconsin, USA.

Kohler Co. Engine Division; Kohler Engines Born to Run Owner's Manual, Command 18–26 HP Horizontal Crankshaft; Cover Sheet, Revised May 1999, Kohler Co. Engine Division, Kohler, Wisconsin, USA.

Kohler Co. Engine Division; Kohler Engines Born to Run Owner's Manual, Command 11–15 HP Horizontal Crankshaft; Cover Sheet, Revised Apr. 1999, Kohler Co. Engine Division, Kohler, Wisconsin, USA.

Kohler Co. Engine Division; Kohler Engines Born to Run Owner's Manual, Magnum 8,12,16 HP Horizontal Crankshaft; Cover Sheet, Revised Dec. 2001, Kohler Co. Engine Division, Kohler, Wisconsin, USA.

Kohler Co. Engine Division; Kohler Engines Service Manual, Courage Series SV470–600 Vertical Crankshaft; website http://www.kohlerengines.com/onlinecatalog/detail.jsp?prod_num=Hydro+13, Cover Sheet, Feb. 2, 2005, Kohler Co. Engine Division, Kohler, Wisconsin, USA.

Kohler Co. Engine Division; Kohler Engines Kohler Triad OHC; website http://www.kohlerengines.com/onlinecatalog/enginefamily.jsp?engine_family_name=Triad+OHC, Cover Sheet Feb. 2, 2005, Kohler Co. Engine Division, Kohler, Wisconsin, USA.

Honda Engines, Honda GC Series Engines, brochure, 2003, 10 pages, American Honda Motor Co, Inc.

KAWASAKI, Four–Cycle Engines, Kawasaki FJ180V, website, http://www.kawpowr.com/4cycle/fj180v_specs.html, 1 page, Feb. 18, 2005.

KAWASAKI, Four–Cycle Engines, kawasaki FC290V, website, http://www.kawpowr.com/4cycle/fc290v_specs.html, 1 page, Feb. 18, 2005.

KAWASAKI, Four–Cycle Engines, Kawasaki FH721D, website, http://www.kawpowr.com/4cycle/fh721d_specs.html, 1 page, Feb. 18, 2005.

KAWASAKI, Four–Cycle Engines, Kawasaki FH601D, website, http://www.kawpowr.com/4cycle/fh601d_specs.html, 1 page, Feb. 18, 2005.

KAWASAKI, Four–Cycle Engines, Kawasaki FH601V, website, http://www.kawpowr.com/4cycle/fh601v_specs.html, 1 page, Feb. 18, 2005.

KAWASAKI, Four–Cycle Engines, Kawasaki FH500V, website, http://www.kawpowr.com/4cycle/fh500v_specs.html, 1 page, Feb. 18, 2005.

KAWASAKI, Four–Cycle Engines, Kawasaki FC150V, website, http://www.kawpowr.com/4cycle/fc150v_specs.html, 1 page, Feb. 18, 2005.

KAWASAKI, Four–Cycle Engines, Kawasaki FH721V, website, http://www.kawpowr.com/4cycle/fh721v_specs.html, 1 page, Feb. 18, 2005.

Tecumseh Power Company, Walk–Behind Engines & Transmissions Horsepower Range: 3.5–7.0, website, <http://www.tecumsehpowers.com/Products/WalkBehind/index.php>, 1 page, Feb. 18, 2005.

Kohler Co. Engine Division, Kohler Engines Born to Run Owner's Manual, Command 11–16 HP Vertical Crankshaft, Cover Sheet, Revised Sep. 1999, Kohler Co. Engine Division, Kohler, Wisconsin, USA.

Kohler Co. Engine Division, Kohler Engines Born to Run Owner's Manual, Command 18–26 HP Horizontal Crankshaft, Cover Sheet, Revised May 1999, Kohler Co Engine Division, Kohler, Wisconsin, USA.

Kohler Co. Engine Division, Kohler Engines Born to Run Owner's Manual, Command 11–15 HP Horizontal Crankshaft, Cover Sheet, Revised Apr. 1999, Kohler Co. Engine Division, Kohler, Wisconsin, USA.

Kohler Co. Engine Division, Kohler Engines Born to Run Owner's Manual, Magnum 8,12,16 HP Horizontal Crankshaft, Cover Sheet, Revised Dec. 2001, Kohler Co. Engine Division, Kohler, Wisconsin, USA.

Kohler Co. Engine Division, Kohler Engines Service Manual, Courage Series SV470–600 Vertical Crankshaft, website http://www.kohlerengines.com/onlinecatalog/detail.jsp?prod_num=Hydro+13, Cover Sheet, Feb. 2, 2005, Kohler Co. Engine Division, Kohler, Wisconsin, USA.

Kohler Co. Engine Division, Kohler Engines Kohler Triad OHC, website http://www.kohlerengines.com/onlinecatalog/enginefamily.jsp?engine_family_name=Triad+OHC, Cover Sheet, Feb. 2, 2005. Kohler Co. Engine Division, Kohler, Wisconsin, USA.

Honda Engines, Honda GC Series Engines, brochure, 2003, 10 pages, American Honda Motor Co., Inc.

Briggs & Stratton, 04 Engine Guide, brochure, 2003, 58 pages, Briggs & Stratton, Wauwatosa, Wisconsin, USA.

* cited by examiner

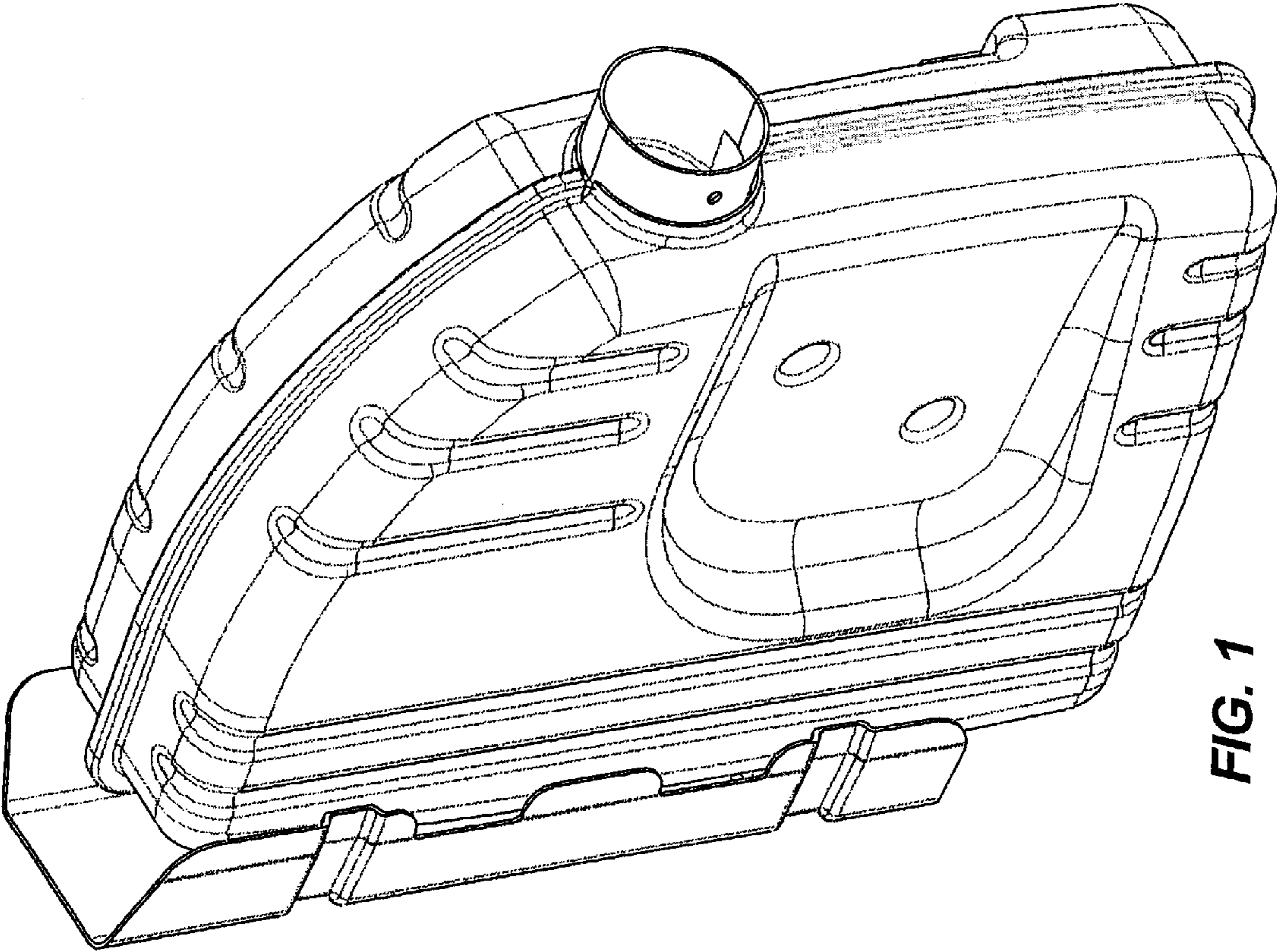

FIG. 1

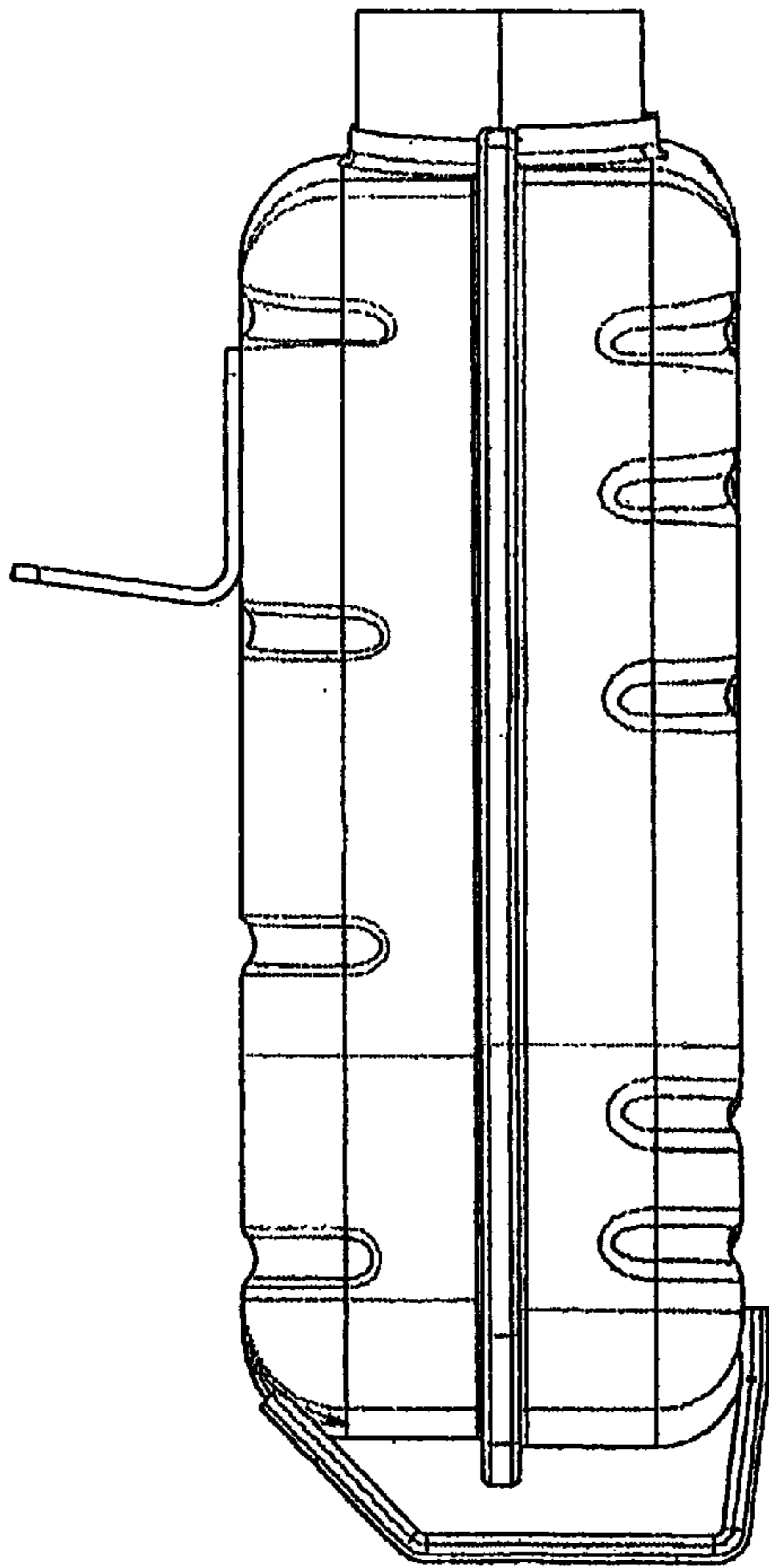

FIG. 2

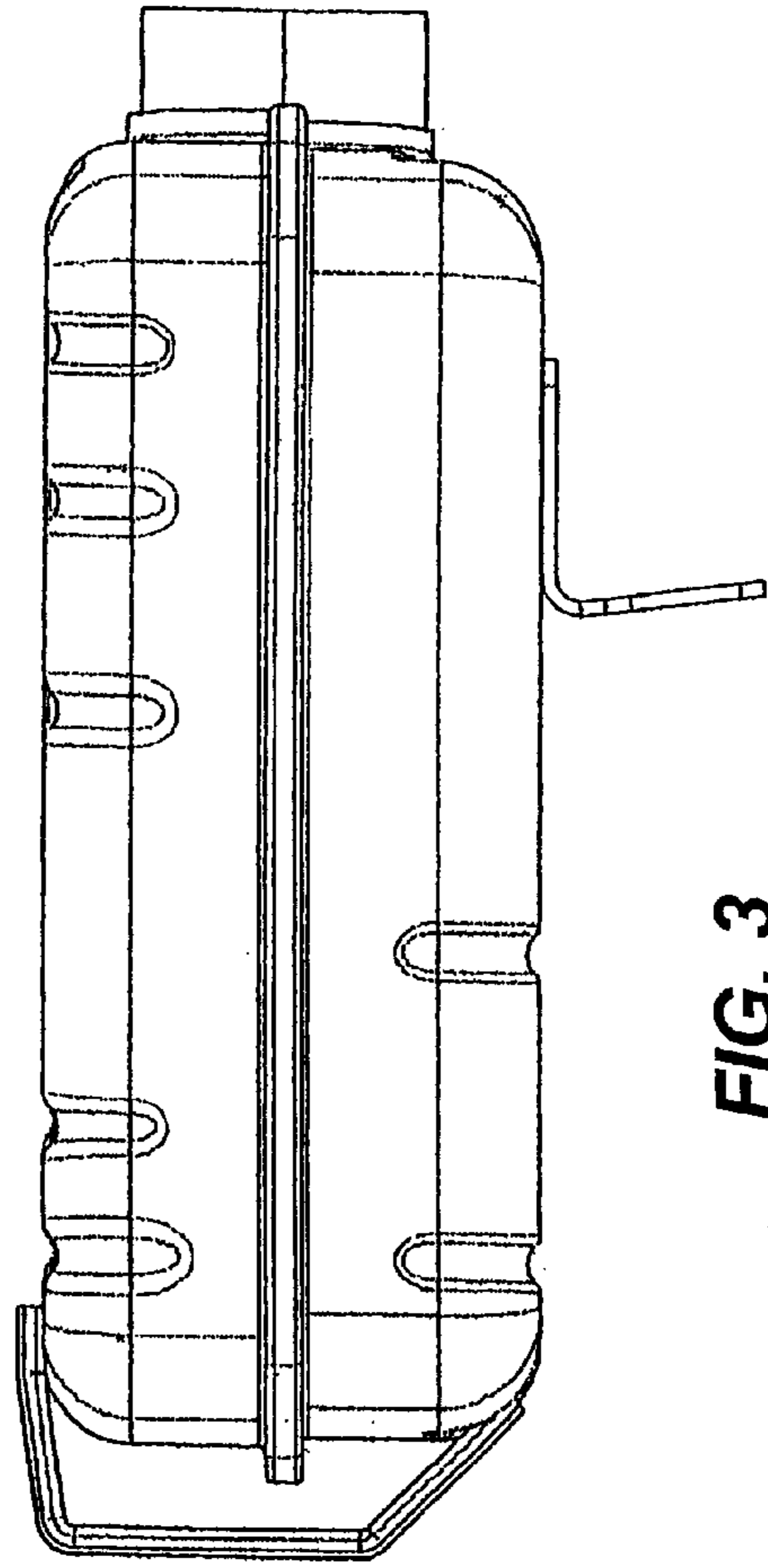

FIG. 3

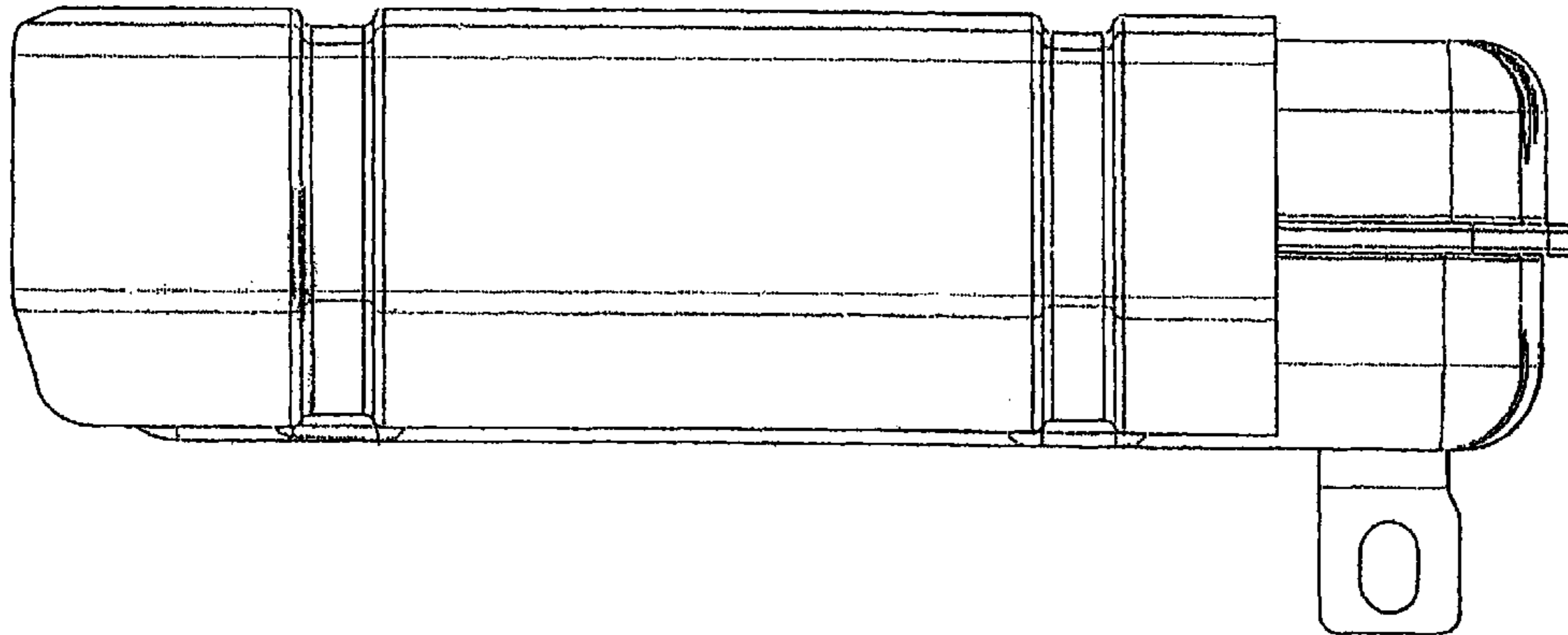

FIG. 5

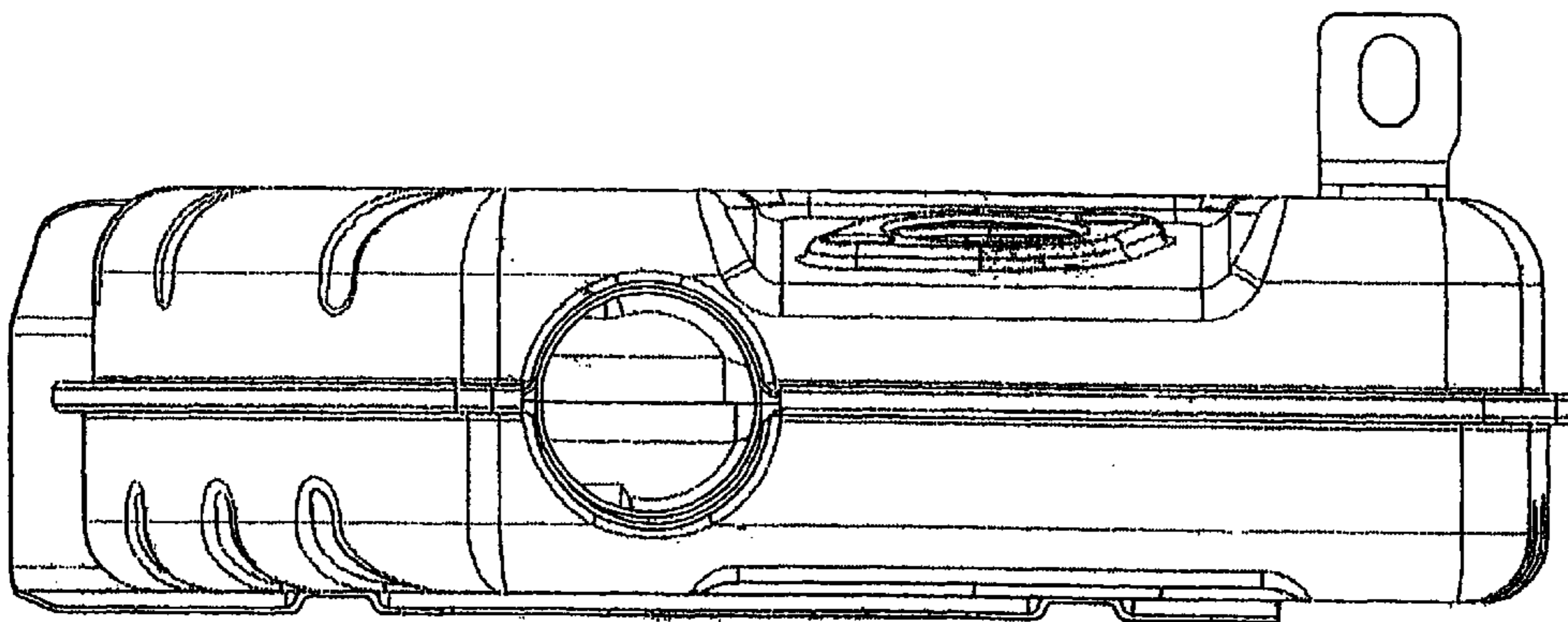

FIG. 4

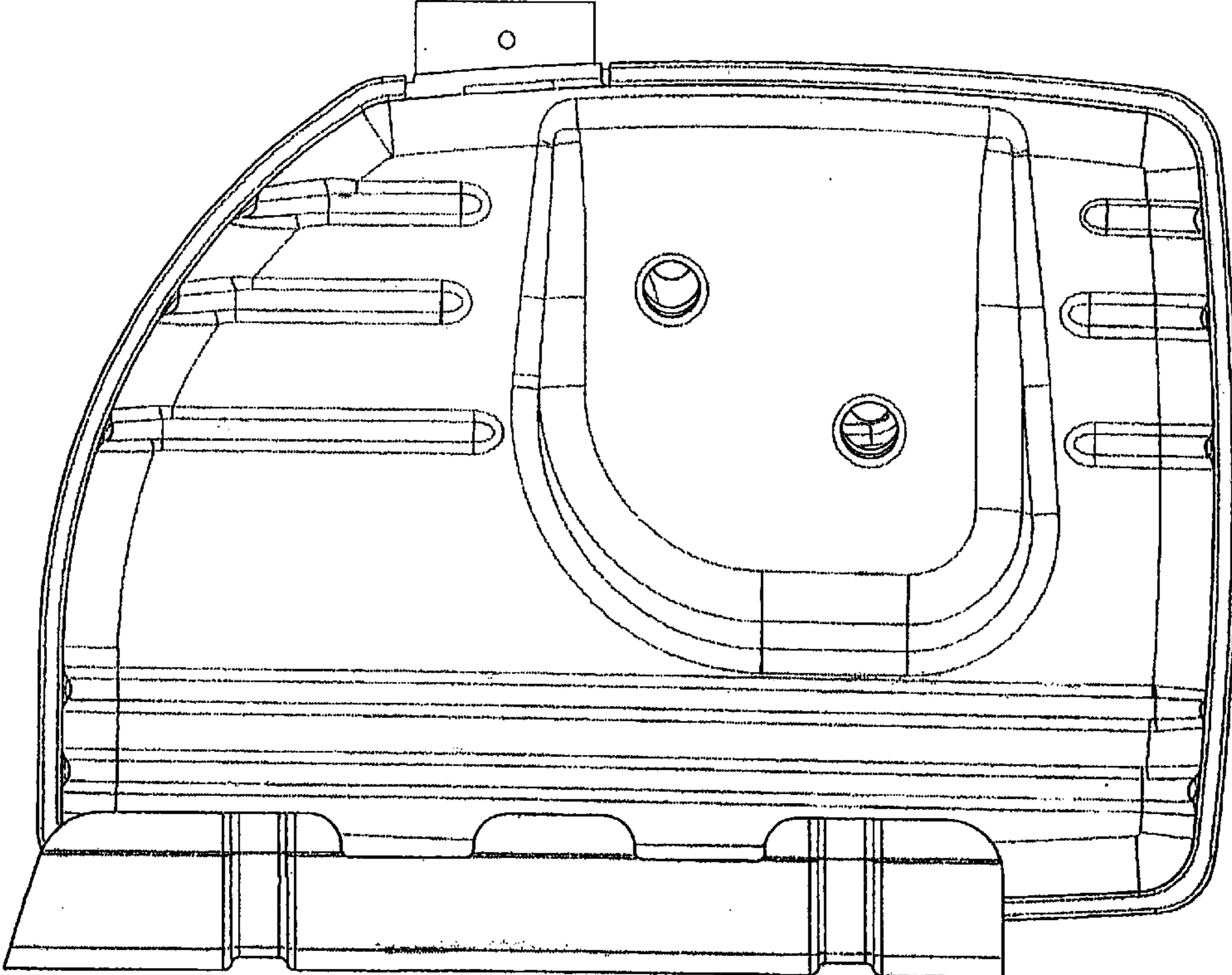

FIG. 6

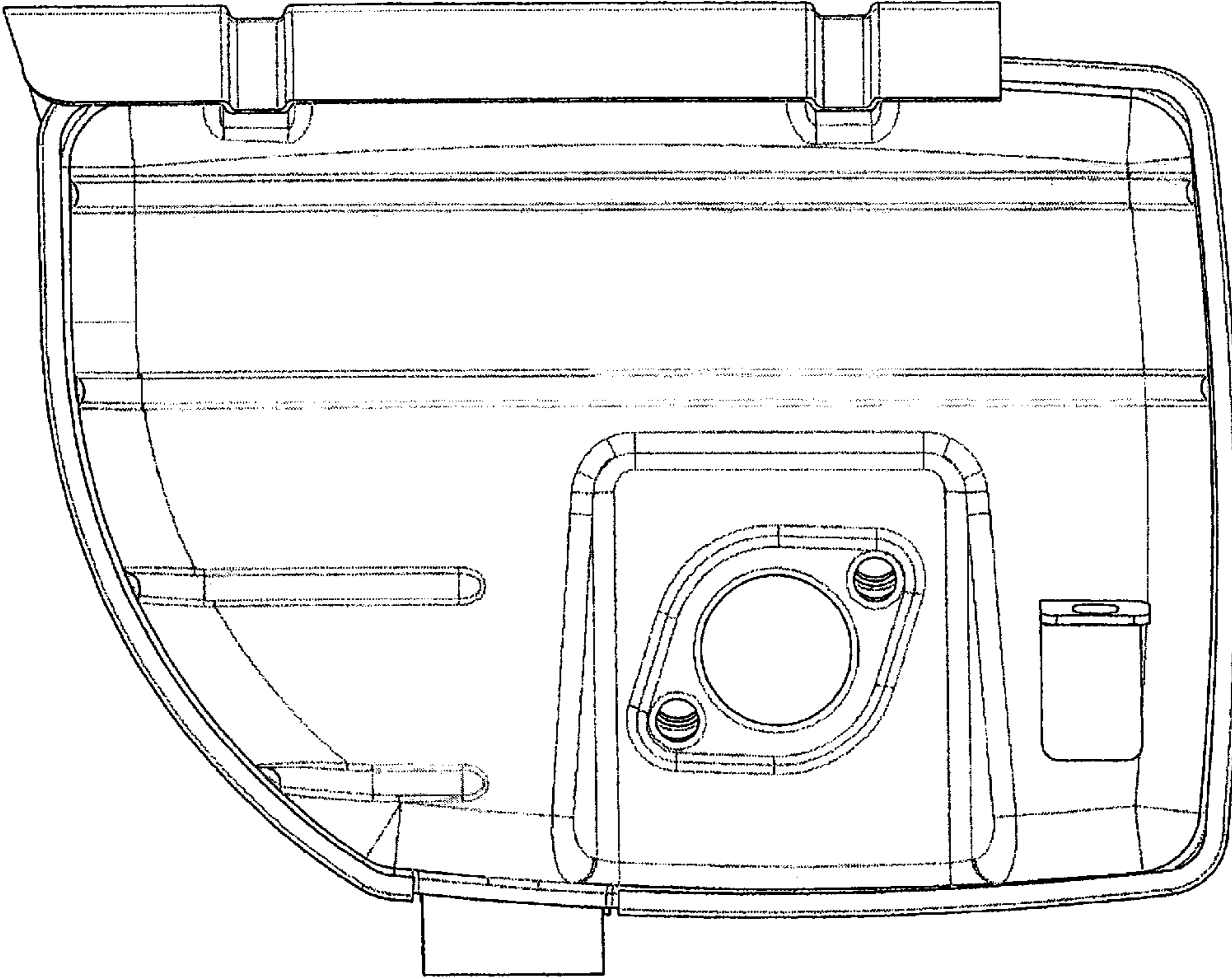

FIG. 7