



US00D537391S

(12) **United States Design Patent**
Shimoguchi et al.

(10) **Patent No.:** **US D537,391 S**

(45) **Date of Patent:** **** Feb. 27, 2007**

(54) **FRONT BUMPER FOR A MOTOR VEHICLE**

(75) Inventors: **Kenta Shimoguchi**, Aichi-ken (JP);
Jinichi Sato, Tokyo (JP)

(73) Assignee: **Toyota Jidosha Kabushiki Kaisha**,
Aichi-ken (JP)

(**) Term: **14 Years**

(21) Appl. No.: **29/253,266**

(22) Filed: **Feb. 3, 2006**

(51) **LOC (8) Cl.** **12-16**

(52) **U.S. Cl.** **D12/169**

(58) **Field of Classification Search** D12/90-92,
D12/86, 169, 196, 163; 296/180.1, 180.2;
293/102, 113, 115, 117, 120
See application file for complete search history.

(56) **References Cited**

U.S. PATENT DOCUMENTS

D484,443 S	*	12/2003	Hattori	D12/169
D497,853 S	*	11/2004	Yanase	D12/169
D498,716 S		11/2004	Maeda et al.		
D503,133 S	*	3/2005	Pfeiffer et al.	D12/169
D506,712 S		6/2005	Suzuki		
D513,213 S		12/2005	Sato		
D516,472 S	*	3/2006	Taguchi	D12/169
D522,938 S	*	6/2006	Iwanaga	D12/169
D526,254 S	*	8/2006	Sowa	D12/169

OTHER PUBLICATIONS

Public relations material, 2003, Nissan Motor Co., Ltd.,
Nissan Titan.
Brochure of TACOMA, 2004 Toyota Jidosha Kabushiki
Kaisha, Toyota Tacoma.

Brochure of Citroen C3, issued by CITROEN Deutschland
AG, Jun. 2003 (1 photograph).

* cited by examiner

Primary Examiner—Melody N. Brown

(74) *Attorney, Agent, or Firm*—Finnegan, Henderson,
Farabow, Garrett & Dunner, L.L.P.

(57) **CLAIM**

The ornamental design for a front bumper for a motor
vehicle, as shown and described.

DESCRIPTION

FIG. 1 is a perspective view of a front bumper for a motor
vehicle of our new design;

FIG. 2 is a front view of our new design;

FIG. 3 is a rear view of our new design;

FIG. 4 is a top view of our new design;

FIG. 5 is a bottom view of our new design;

FIG. 6 is a right-side view of our new design, the left-side
view being a mirror image thereof;

FIG. 7 is a cross-sectional view of our new design taken
along the line 7—7 in FIG. 2, showing the profile of that
portion of the design;

FIG. 8 is a cross-sectional view of our new design taken
along the line 8—8 in FIG. 2, showing the profile of that
portion of the design; and,

FIG. 9 is a cross-sectional view of our new design taken
along the line 9—9 in FIG. 2, showing the profile of that
portion of the design.

As used herein, right and left refer to the orientation of the
design depicted in the figures above, not the right and left
sides of the design when mounted on a motor vehicle.

1 Claim, 5 Drawing Sheets

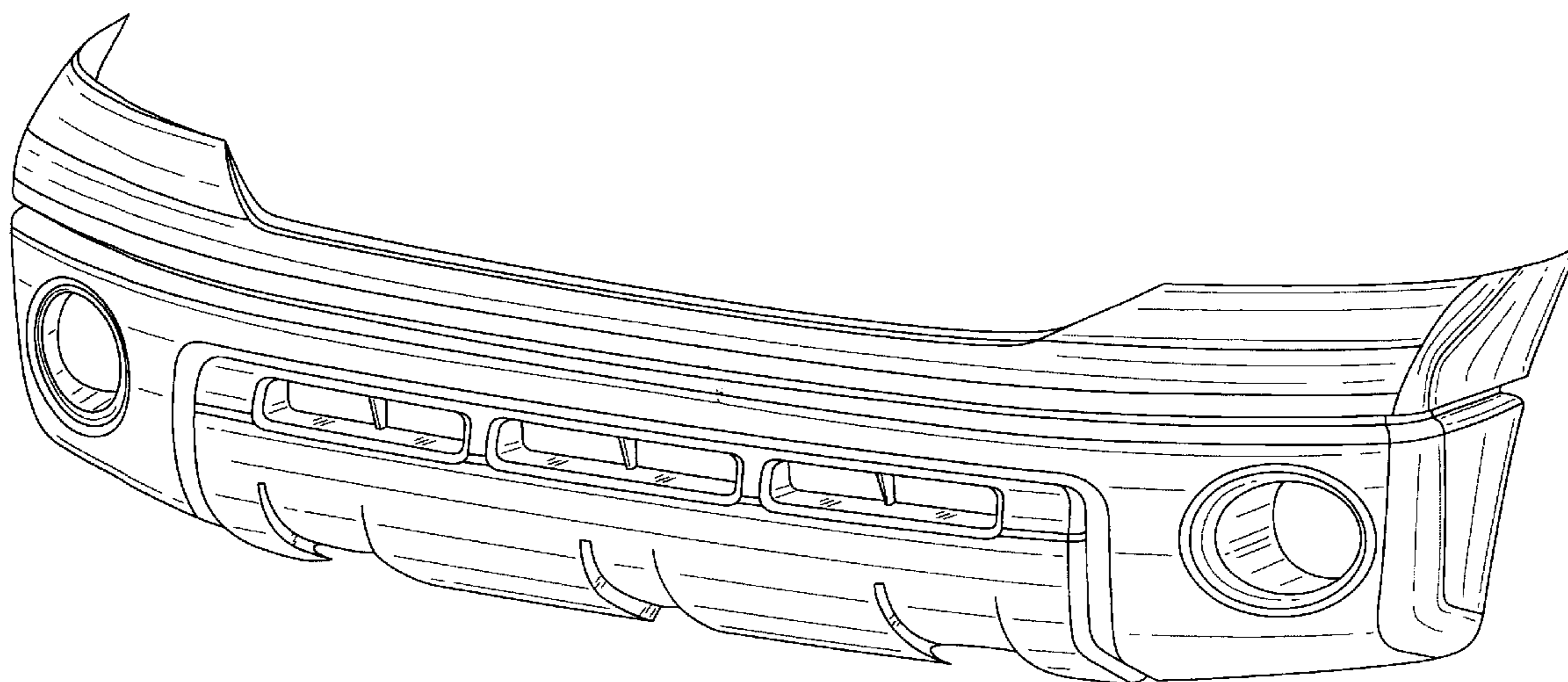

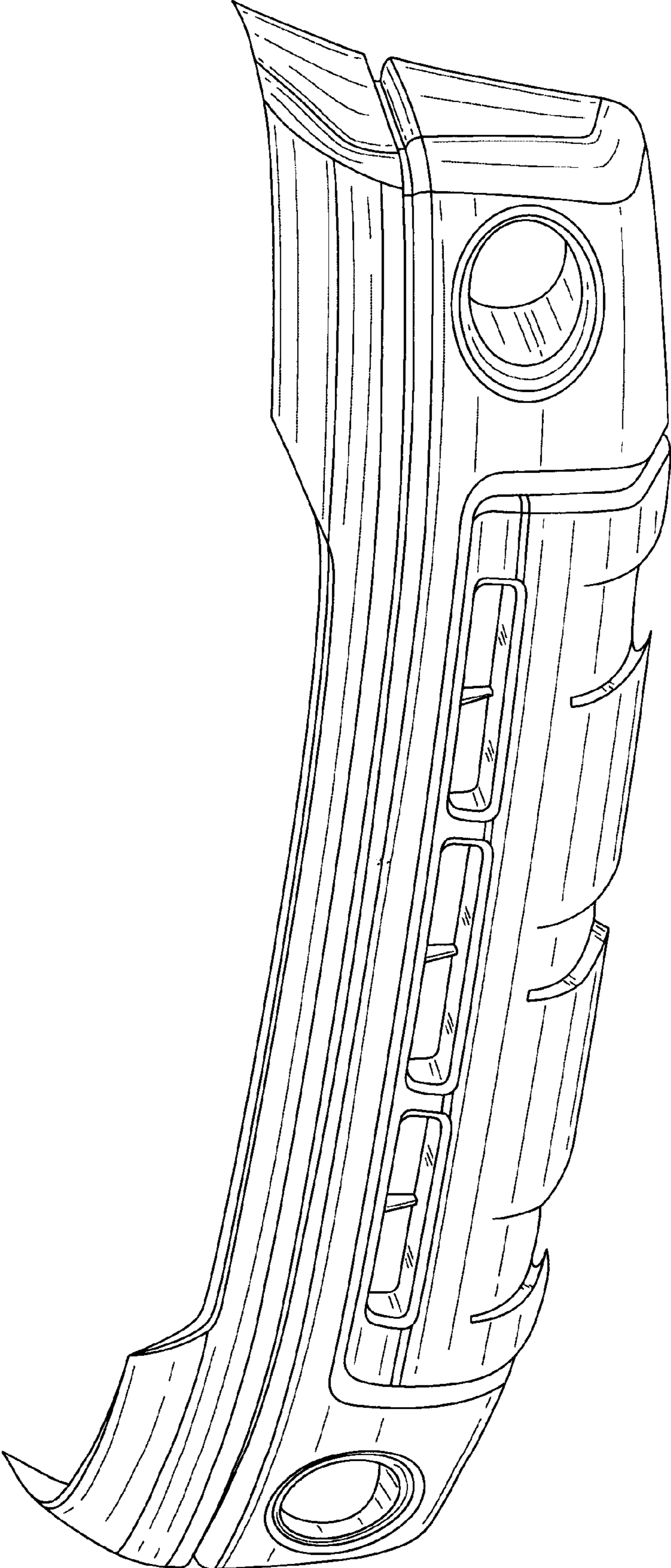
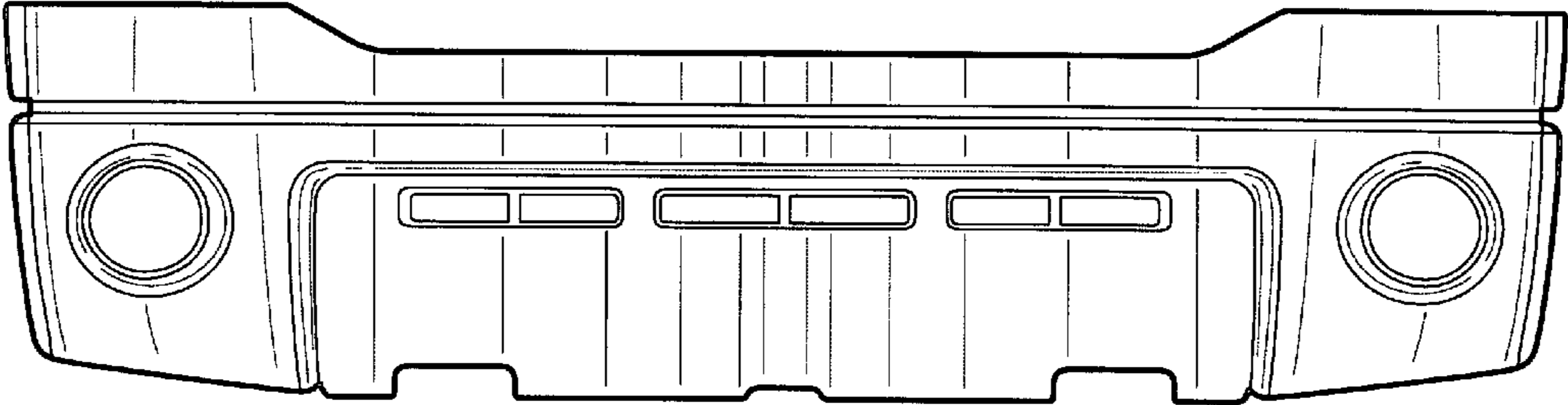
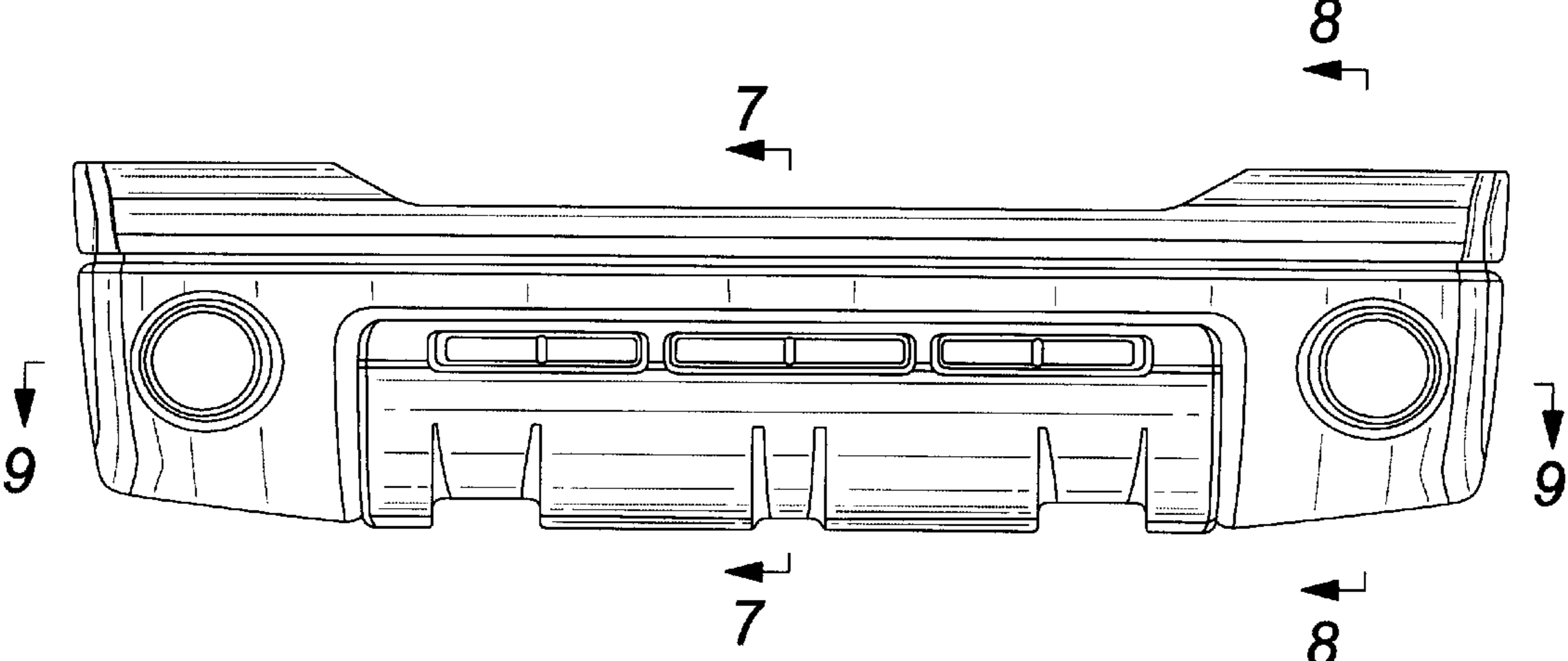

FIG. 1



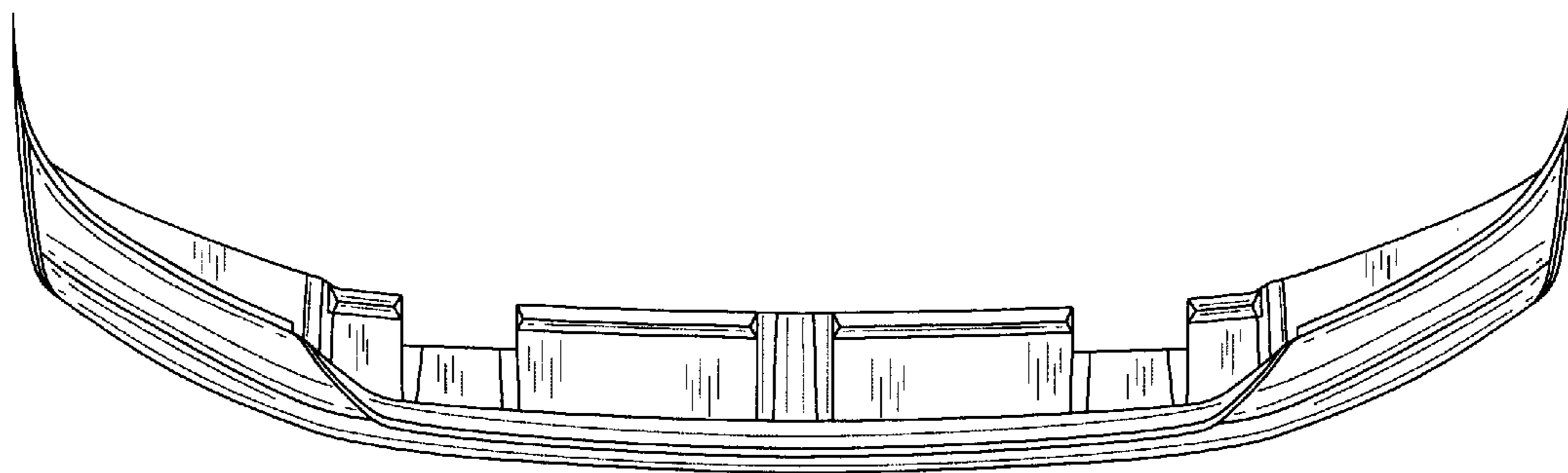

FIG. 4

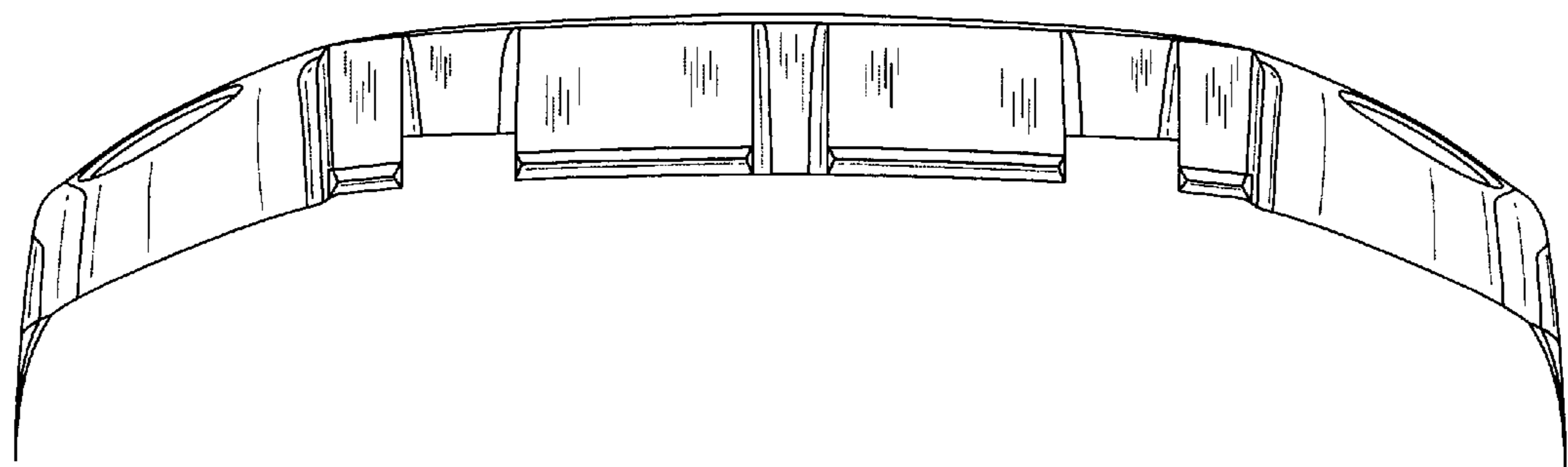

FIG. 5

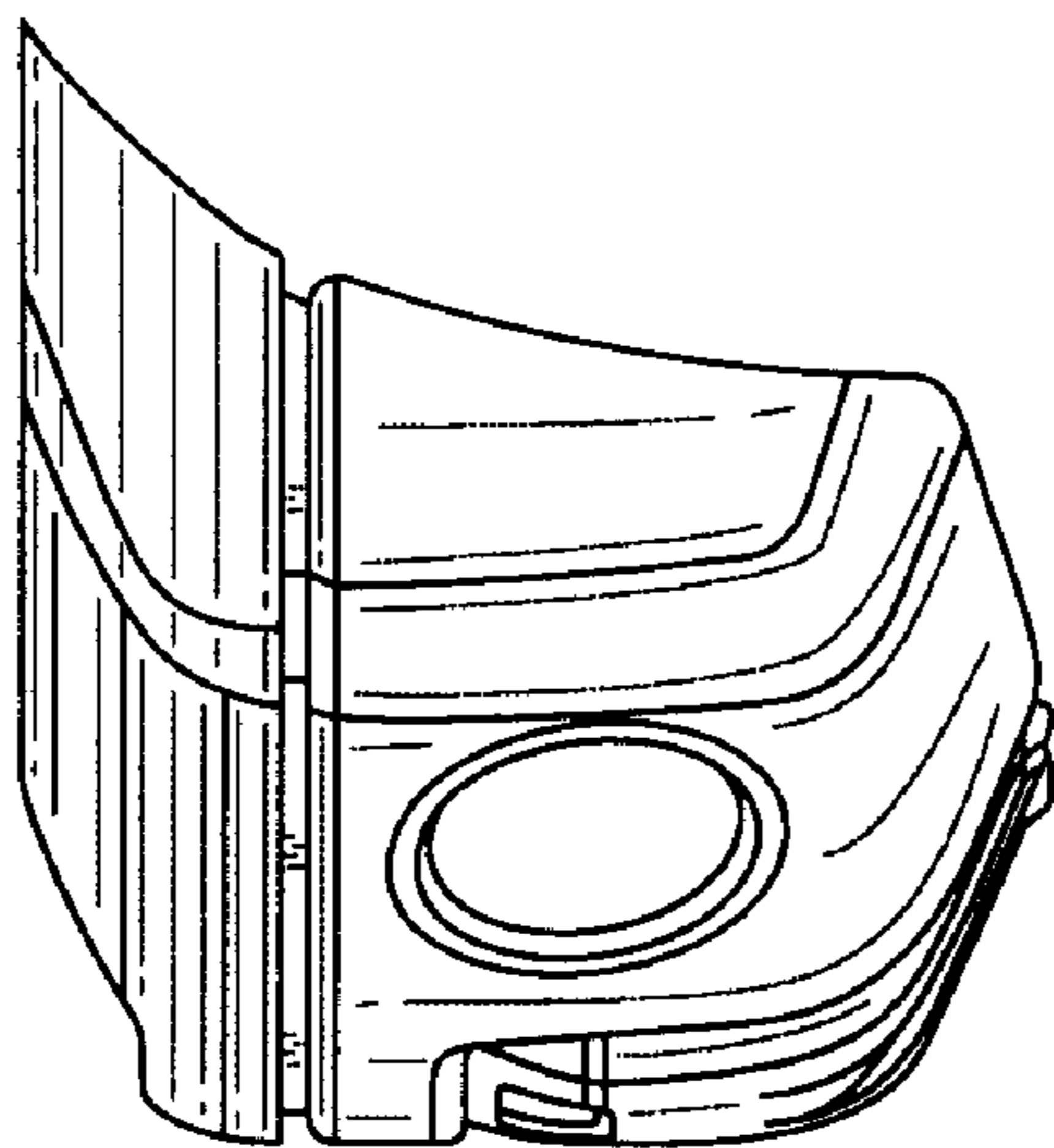

FIG. 6

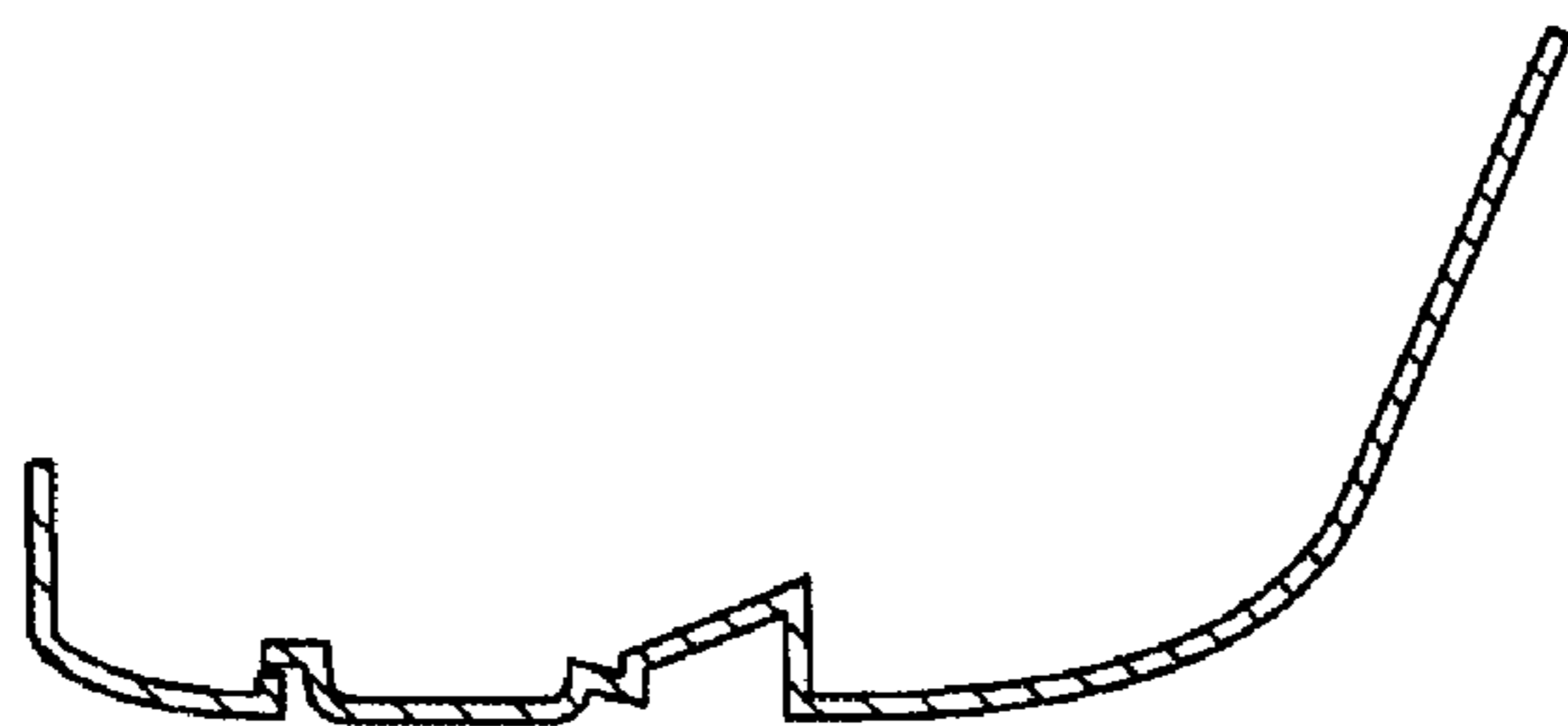

FIG. 7

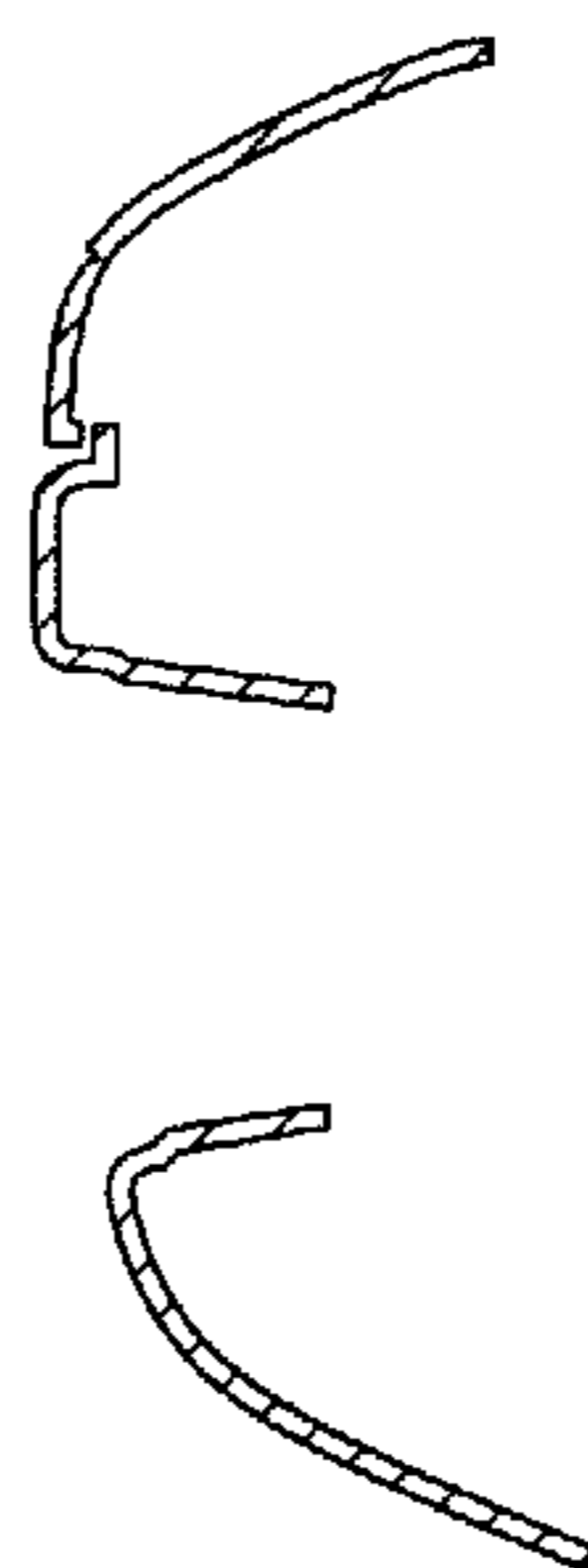

FIG. 8

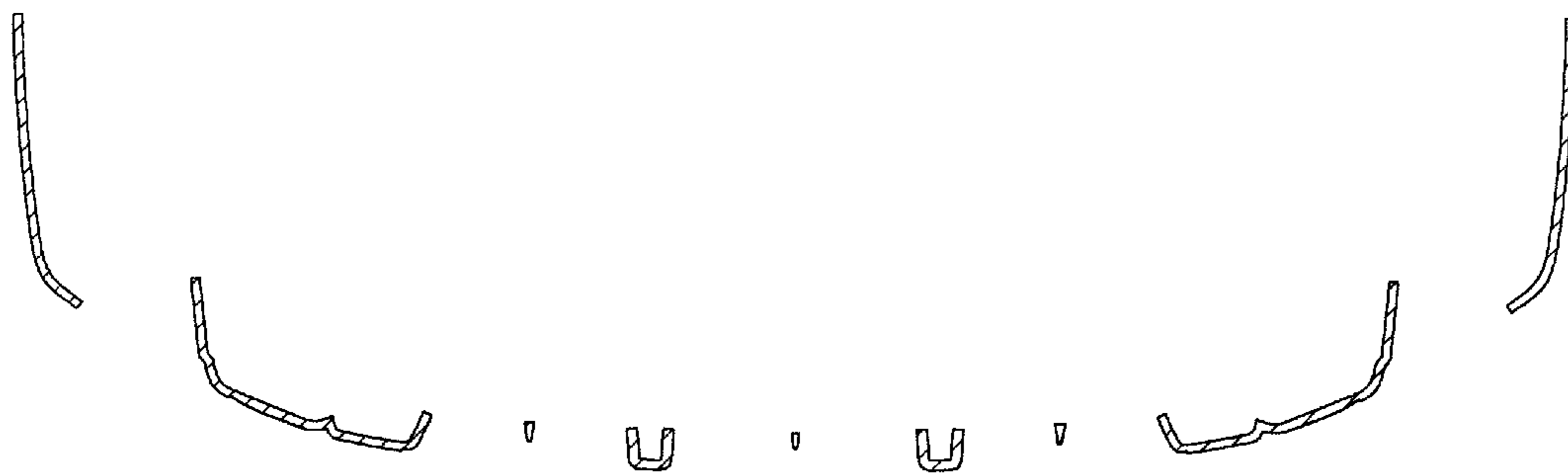

FIG. 9