



US00D537390S

(12) **United States Design Patent**
Golden et al.

(10) **Patent No.:** **US D537,390 S**

(45) **Date of Patent:** **** Feb. 27, 2007**

(54) **VEHICLE LOWER REAR BUMPER**

(75) Inventors: **Edward Golden**, Pinckney, MI (US);
Darrell Behmer, Novi, MI (US);
Melvin Betancourt, Shelby Township,
MI (US); **Solomon Song**, Farmington
Hills, MI (US); **Shawn Wehrly**, Royal
Oak, MI (US); **Addam Ebel**, Dearborn,
MI (US); **Sang Kim**, Canton, MI (US);
Garen Nicoghosian, Beverly Hills, MI
(US)

(73) Assignee: **Ford Global Technologies, LLC**,
Dearborn, MI (US)

(**) Term: **14 Years**

(21) Appl. No.: **29/241,530**

(22) Filed: **Oct. 27, 2005**

(51) **LOC (8) Cl.** **12-16**

(52) **U.S. Cl.** **D12/169**

(58) **Field of Classification Search** D12/90-92,
D12/86, 169, 196; 296/180.1, 180.2; 293/102,
293/113, 115, 117, 120

See application file for complete search history.

(56) **References Cited**

U.S. PATENT DOCUMENTS

D497,579 S * 10/2004 Metros et al. D12/169
D503,135 S * 3/2005 Metros et al. D12/169
D508,880 S * 8/2005 Minami D12/169

OTHER PUBLICATIONS

AutoWeek.com, *2007 Edge*, Jul. 6, 2005; <http://forums.au-toweek.com/thread.jspa?forumID=235&threadID=17785&messageID=388305>.

TheCarConnection.com, TCC Message Boards—*Concepts, Spy Shots and Future Cars—2007 Ford Edge*, Aug. 11, 2005 <http://forum.thecarconnection.com/showthread.php?t=2416>.

Chicago Tribune—Online Edition, *The 2007 Ford Edge crossover vehicle, derived from the Mazda6 sedan, will make its debut early next year.* Aug. 24, 2005 <http://www.chicagotribune.com/classified/automotive/chi-050824mateja-pix,1,5840997.photo?coll=chi-classifiedcars-hed>.

Popular Mechanics Online, *PM.com Exclusive: 2 Look-a-like Mules*, Sep. 8, 2005 http://www.popularmechanics.com/automotive/spy_reports/1829262.html.

Edmunds.com, *New Ford Edge Crossover Caught Testing*, Sep. 26, 2005 <http://www.edmunds.com/insideline/do/Features/articleId=107367>.

* cited by examiner

Primary Examiner—Melody N. Brown

(74) *Attorney, Agent, or Firm*—Frederick Owens

(57) **CLAIM**

The ornamental design for a vehicle lower rear bumper, as shown and described in FIGS. 1-7.

DESCRIPTION

FIG. 1 is a front perspective view of a vehicle lower rear bumper;

FIG. 2 is a front elevation view of the vehicle lower rear bumper;

FIG. 3 is a top plan view of the vehicle lower rear bumper;

FIG. 4 is a left side elevation view of the vehicle lower rear bumper;

FIG. 5 is a right side elevation view of the vehicle lower rear bumper;

FIG. 6 is bottom plan view of the vehicle lower rear bumper; and,

FIG. 7 is a rear elevation view of the vehicle lower rear bumper.

The broken lines are for illustrative purposes only and form no part of the claimed design.

1 Claim, 7 Drawing Sheets

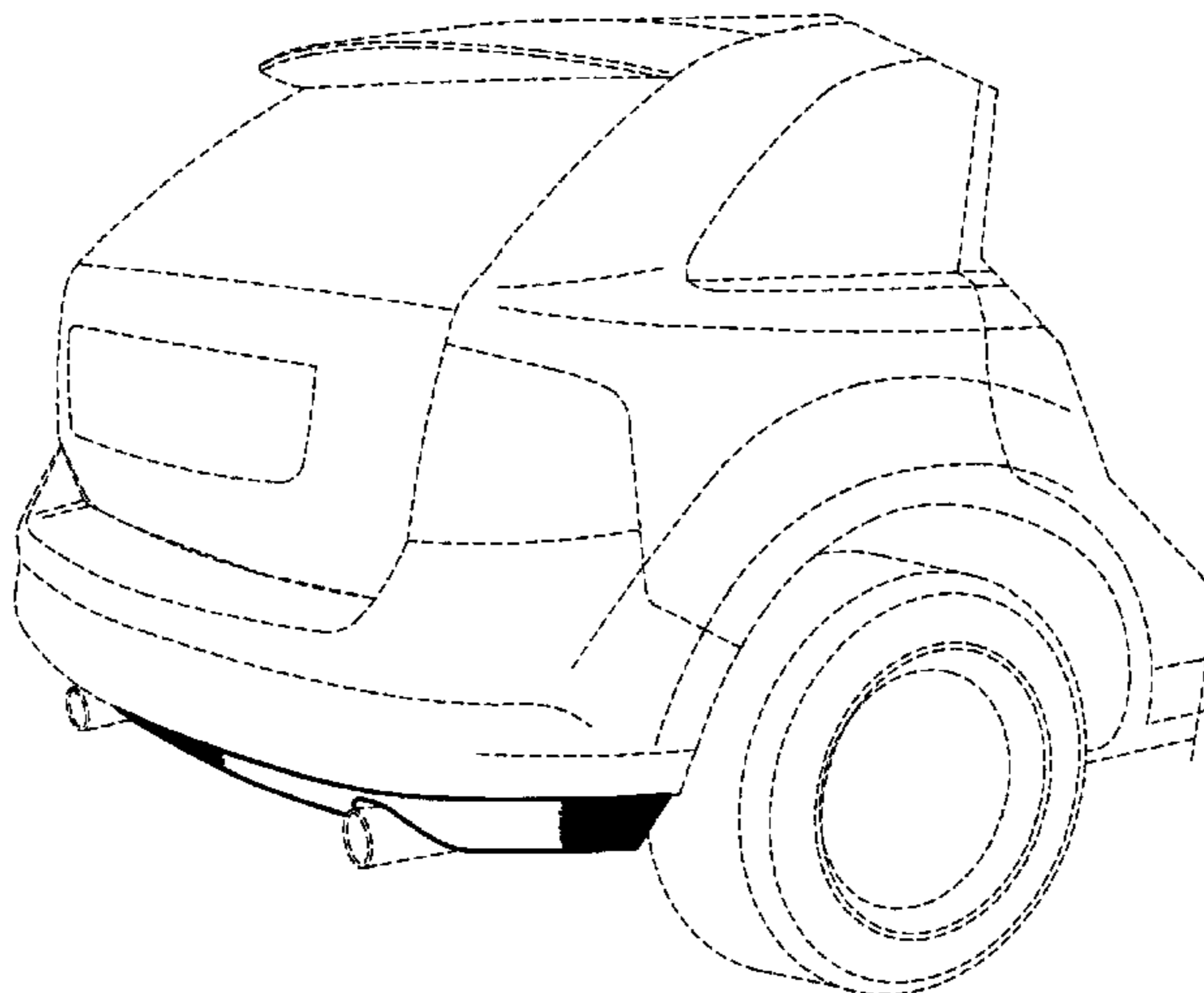

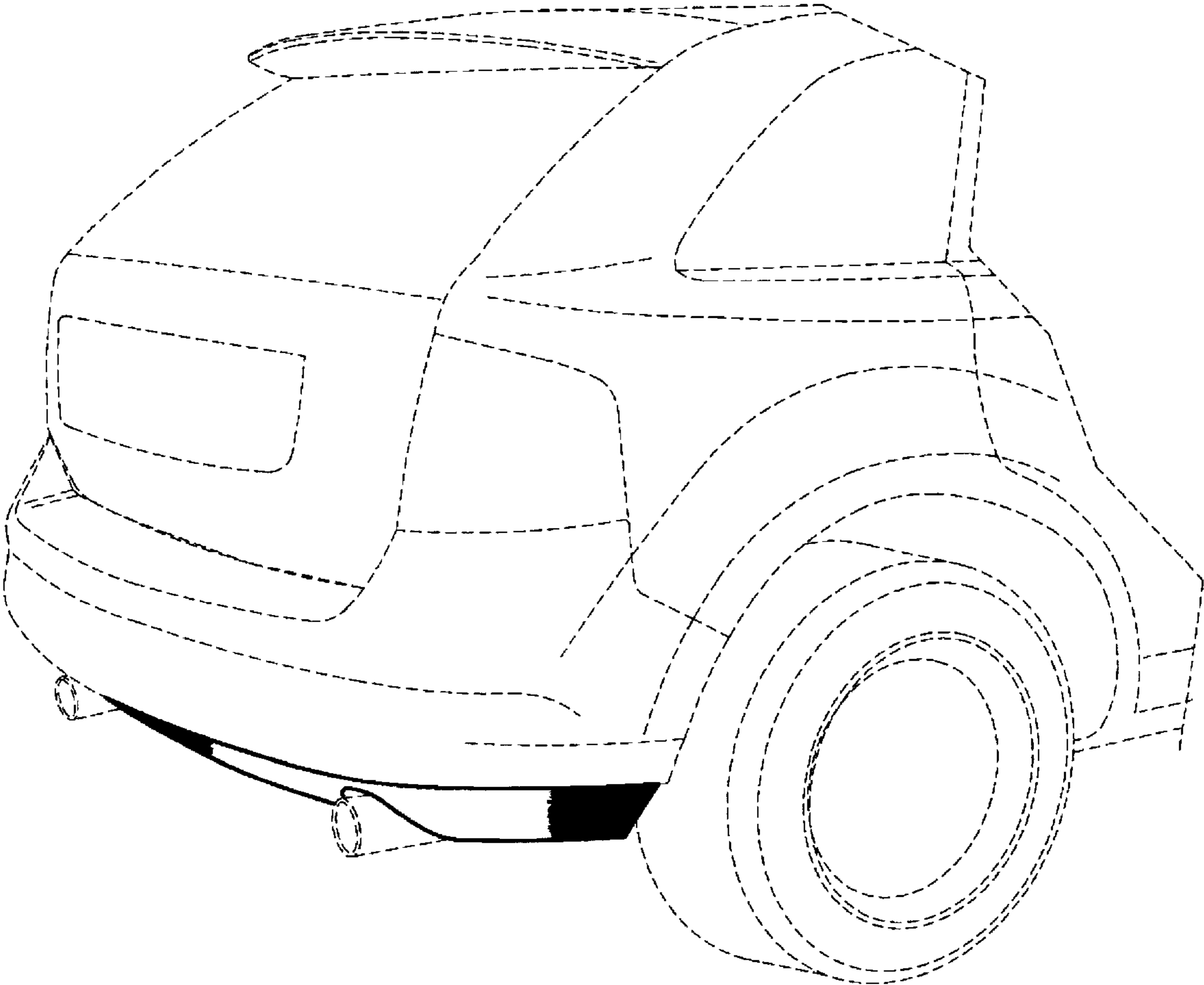

FIG - 1

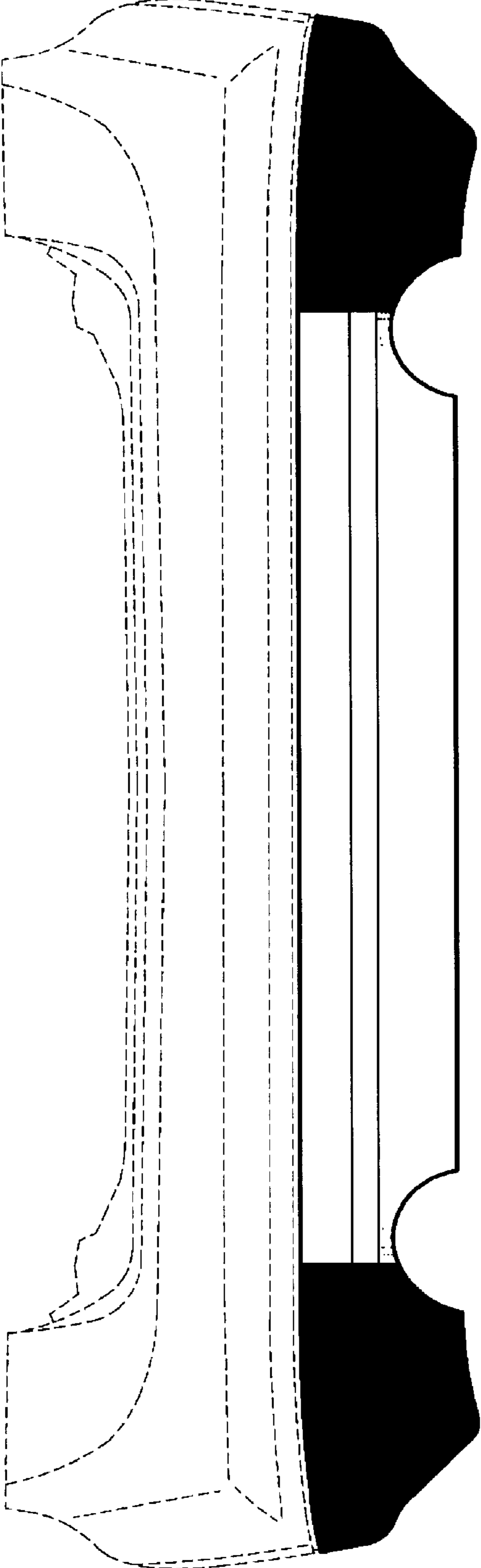

FIG - 2

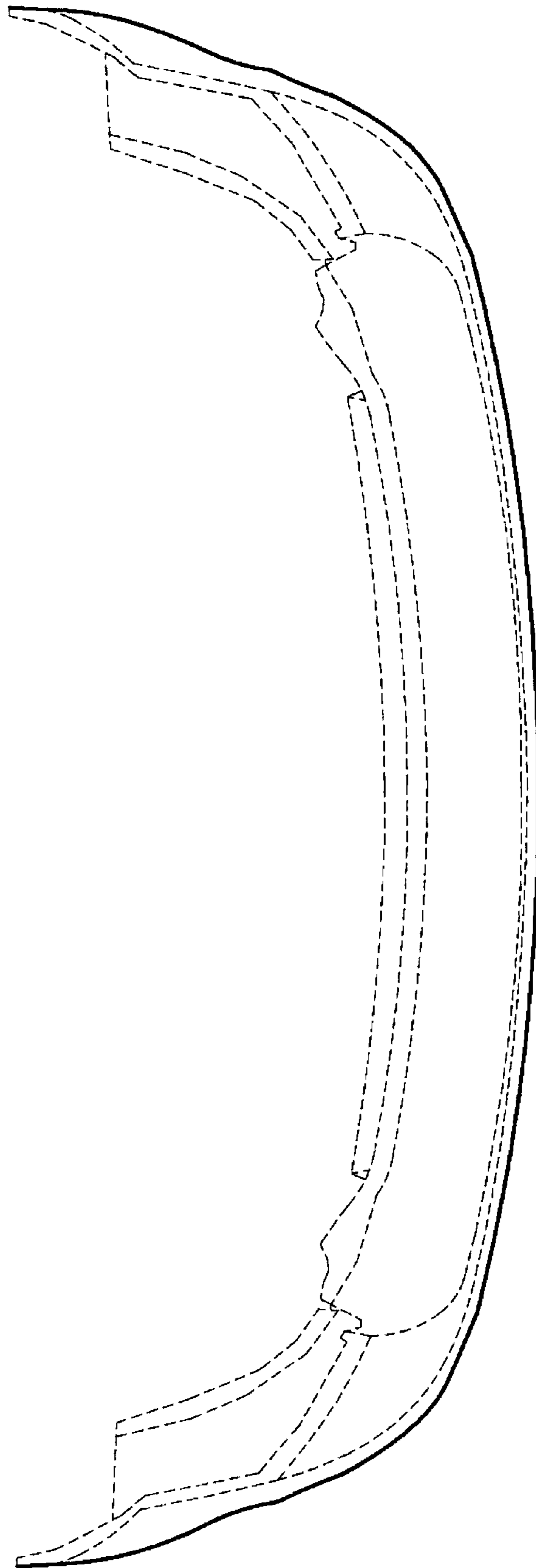

FIG - 3

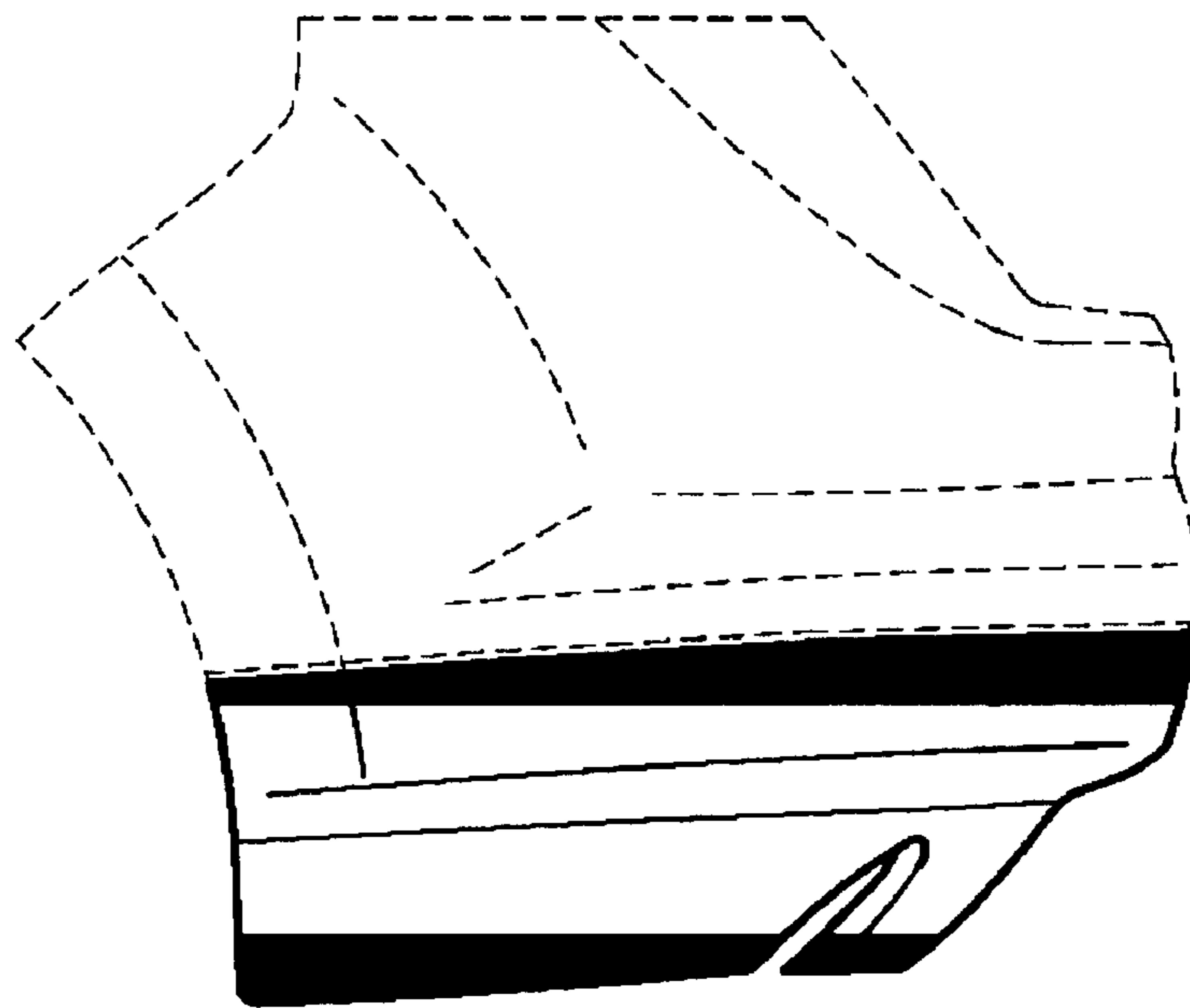

FIG - 4

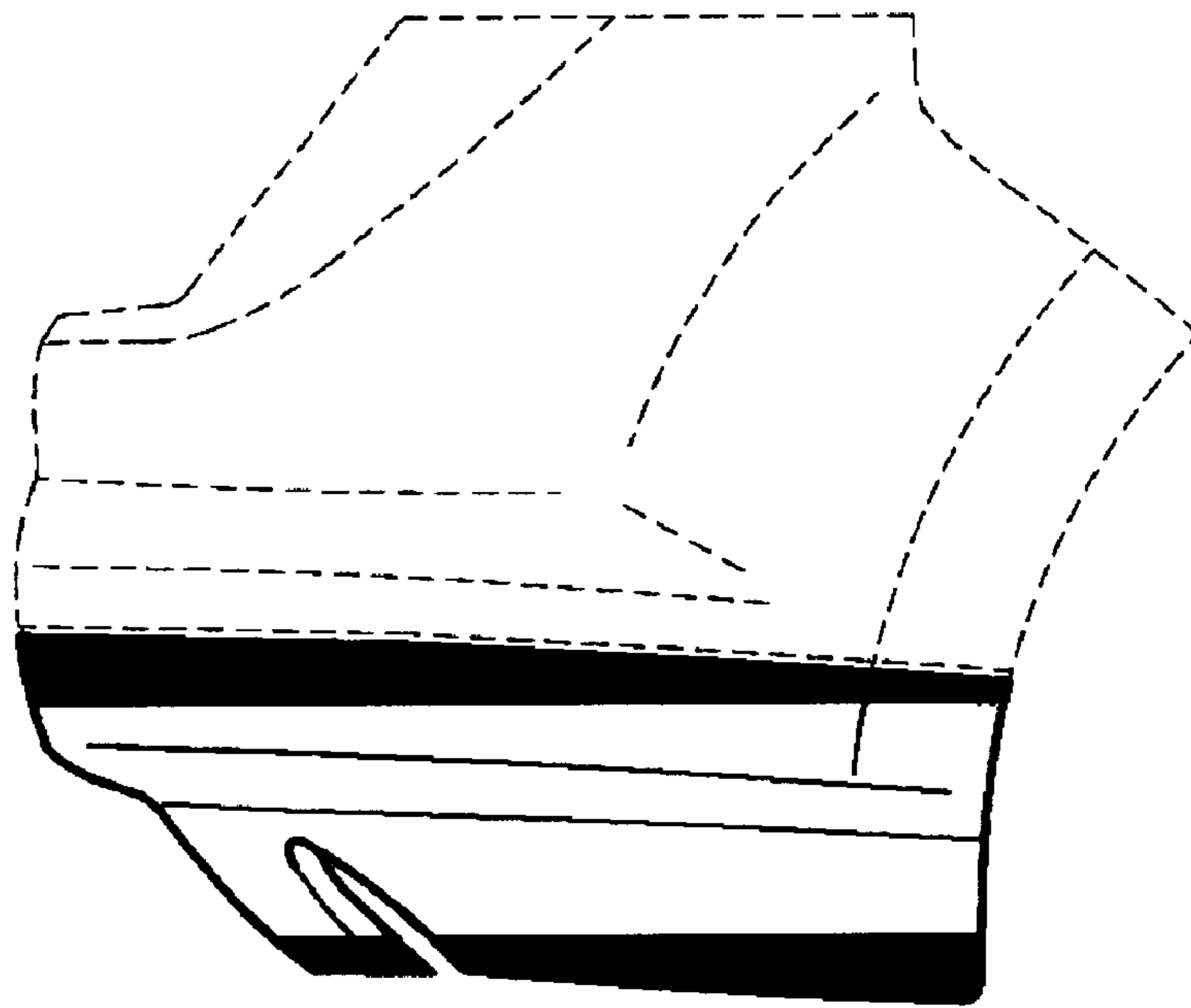

FIG - 5

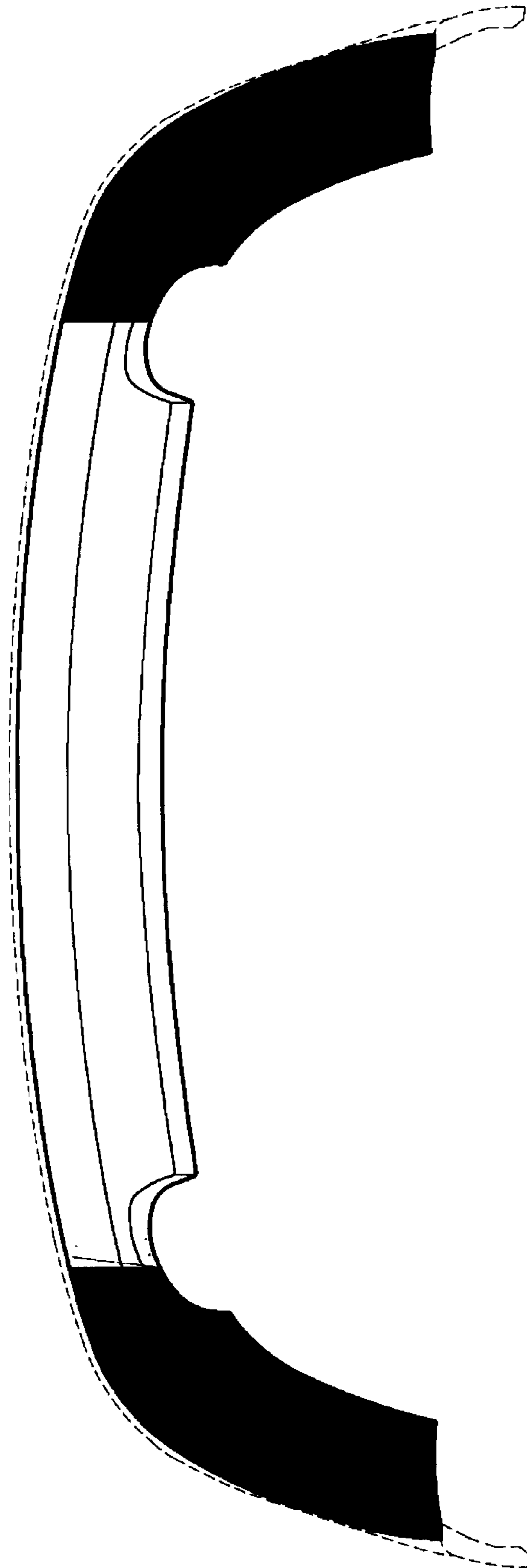

FIG - 6

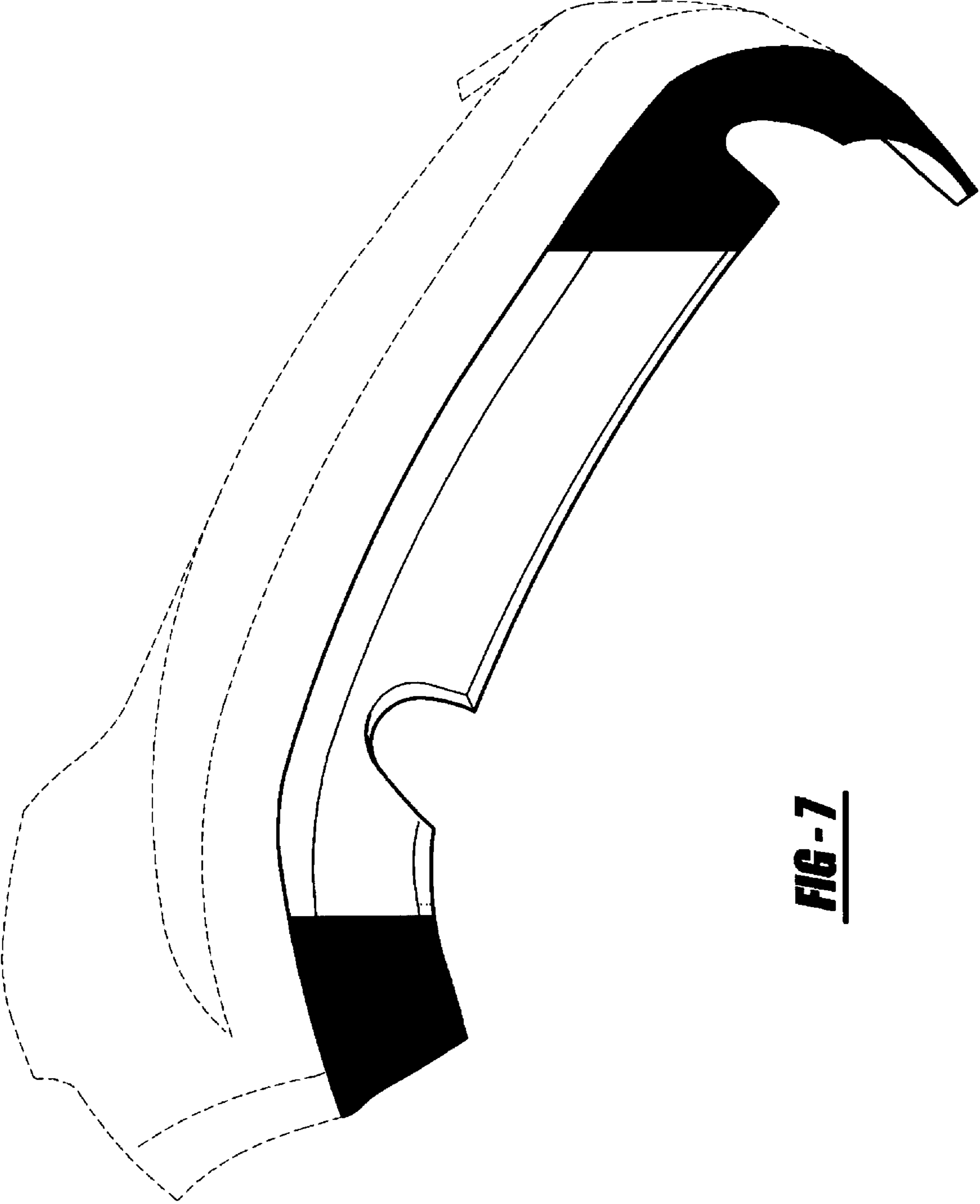

FIG-7