



US00D537031S

(12) **United States Design Patent** (10) **Patent No.:** **US D537,031 S**
Hoy et al. (45) **Date of Patent:** **** Feb. 20, 2007**

(54) **SOFT TOP FOR A SPORT UTILITY VEHICLE**

(75) Inventors: **April L. Hoy**, Denver, CO (US);
Michele L. Martinez, Thornton, CO (US);
Antony J. Aspland, Denver, CO (US);
Stanley V. Spate, Westminster, CO (US)

(73) Assignee: **Bestop, Inc.**, Broomfield, CO (US)

(**) Term: **14 Years**

(21) Appl. No.: **29/216,236**

(22) Filed: **Oct. 28, 2004**

(51) **LOC (8) Cl.** **12-16**

(52) **U.S. Cl.** **D12/401**

(58) **Field of Classification Search** D12/401,
D12/403-404, 409, 412, 173, 196, 89, 91;
294/446; 296/114-116; 29/450, 446, 448
See application file for complete search history.

(56) **References Cited**

U.S. PATENT DOCUMENTS

D198,780	S	*	8/1964	Hines	D12/404
3,167,349	A	*	1/1965	Young et al.	296/100.1
D250,330	S	*	11/1978	Hickman et al.	D12/403
D268,408	S	*	3/1983	Ruggles	D12/403
4,877,283	A	*	10/1989	Little et al.	296/100.18
D322,055	S	*	12/1991	Bruce et al.	D12/403
5,299,850	A	*	4/1994	Kaneko et al.	296/107.13
5,765,903	A	*	6/1998	Essig et al.	296/102
D408,781	S	*	4/1999	Gordon	D12/401
D442,911	S	*	5/2001	Essig et al.	D12/404
6,295,713	B1	*	10/2001	Hilliard et al.	29/446
D474,145	S	*	5/2003	Dawson et al.	D12/401
6,932,423	B2	*	8/2005	Stevens et al.	296/224

OTHER PUBLICATIONS

Bestop: <http://www.bestop.com/index.php?a=16&pid=411>;
Press release: Introducing the YJ Halftop from Bestop (2 pages), Apr. 14, 2003.*

Sales brochure of Bestop, Inc., 2003.
Special Edition 2001 of "Essentials" (Quadratec, 2001 pp. 17-19, 26, 28, and 31).

Installation Instruction Sheets for the Cab Top of Rock Crusher, 2001.

Photocopies of a soft top of Bestop, Inc. (3 sheets) 2003.

* cited by examiner

Primary Examiner—Caron D. Veynar

Assistant Examiner—Kelley A. Donnelly

(74) *Attorney, Agent, or Firm*—W. Scott Carson

(57) **CLAIM**

The ornamental design for a soft top for a sport utility vehicle, as shown and described.

DESCRIPTION

FIG. 1 is a perspective view of a soft top for a sport utility vehicle showing our new design.

FIG. 2 is a right side elevational view thereof, the left side elevational view being identical thereto.

FIG. 3 is a front elevational view thereof.

FIG. 4 is a rear elevational view thereof.

FIG. 5 is a top plan view thereof.

FIG. 6 is a bottom plan view thereof.

FIG. 7 is a perspective view of a soft top for a sport utility vehicle showing our new design.

FIG. 8 is a right side elevational view thereof, the left side elevational view being identical thereto.

FIG. 9 is a front elevational view thereof.

FIG. 10 is a rear elevational view thereof.

FIG. 11 is a top plan view thereof; and,

FIG. 12 is a bottom plan view thereof.

The broken lines in the drawings are for illustrative purposes only and form no part of the claimed design.

1 Claim, 8 Drawing Sheets

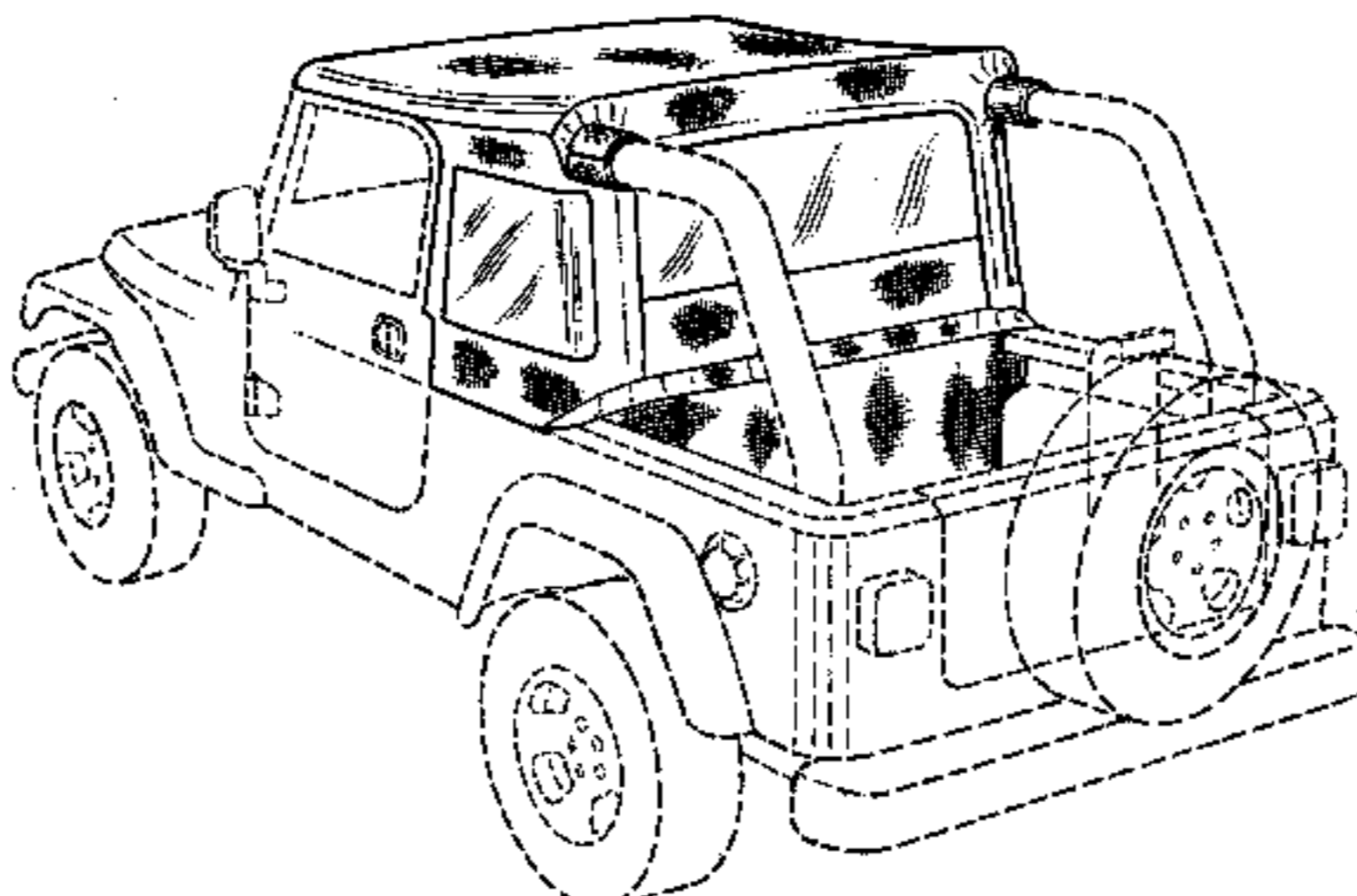
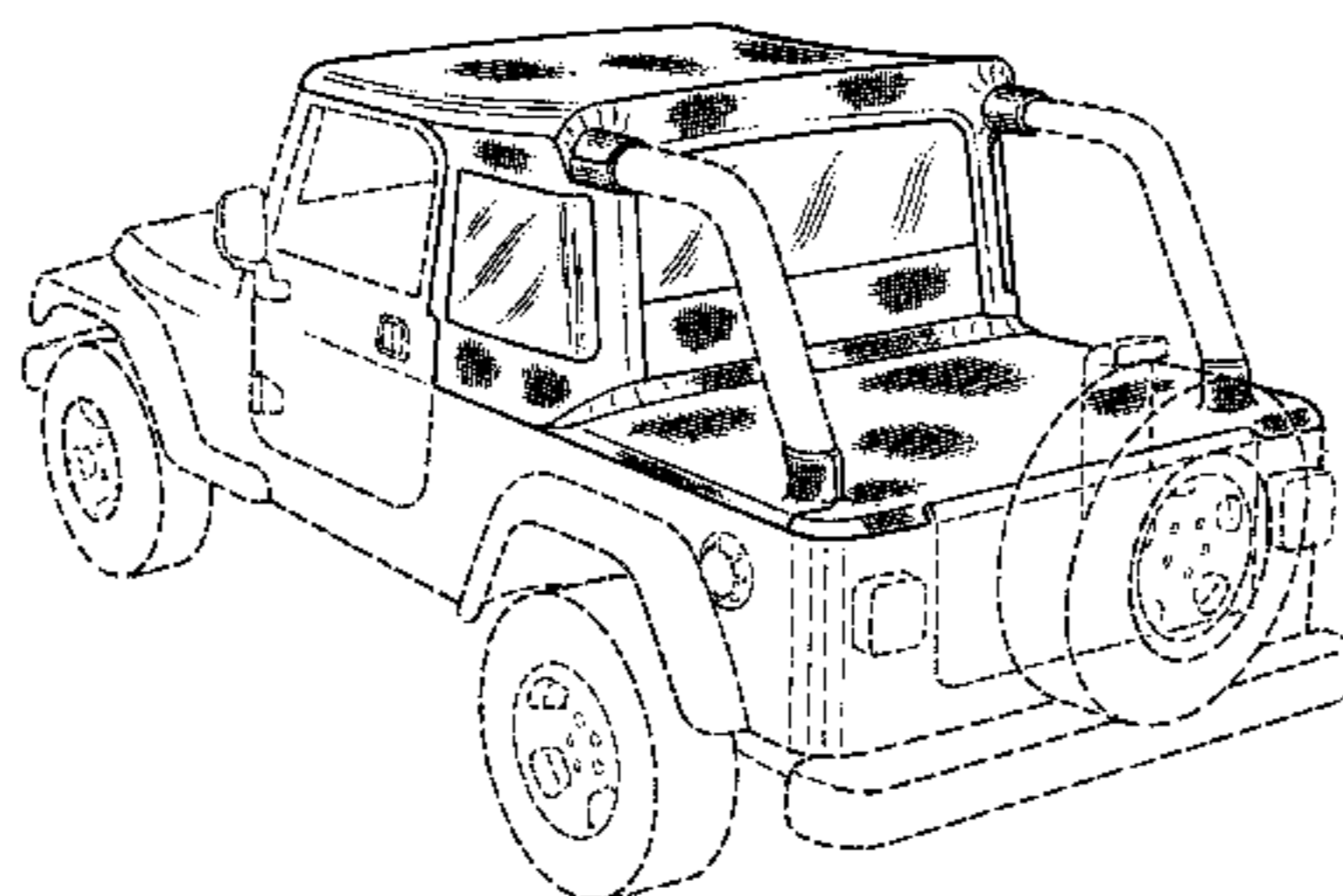

Fig. 1

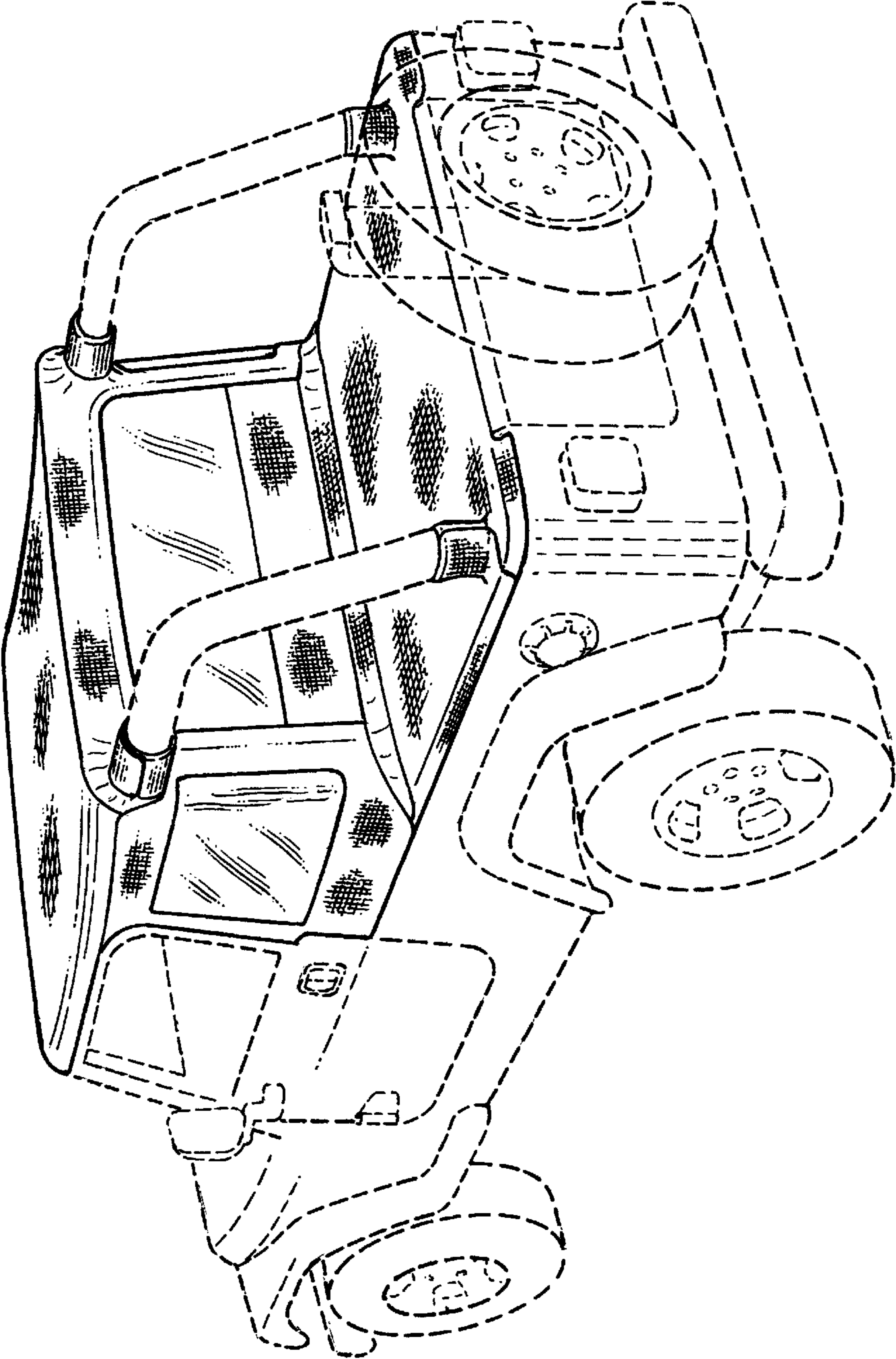

Fig. 2

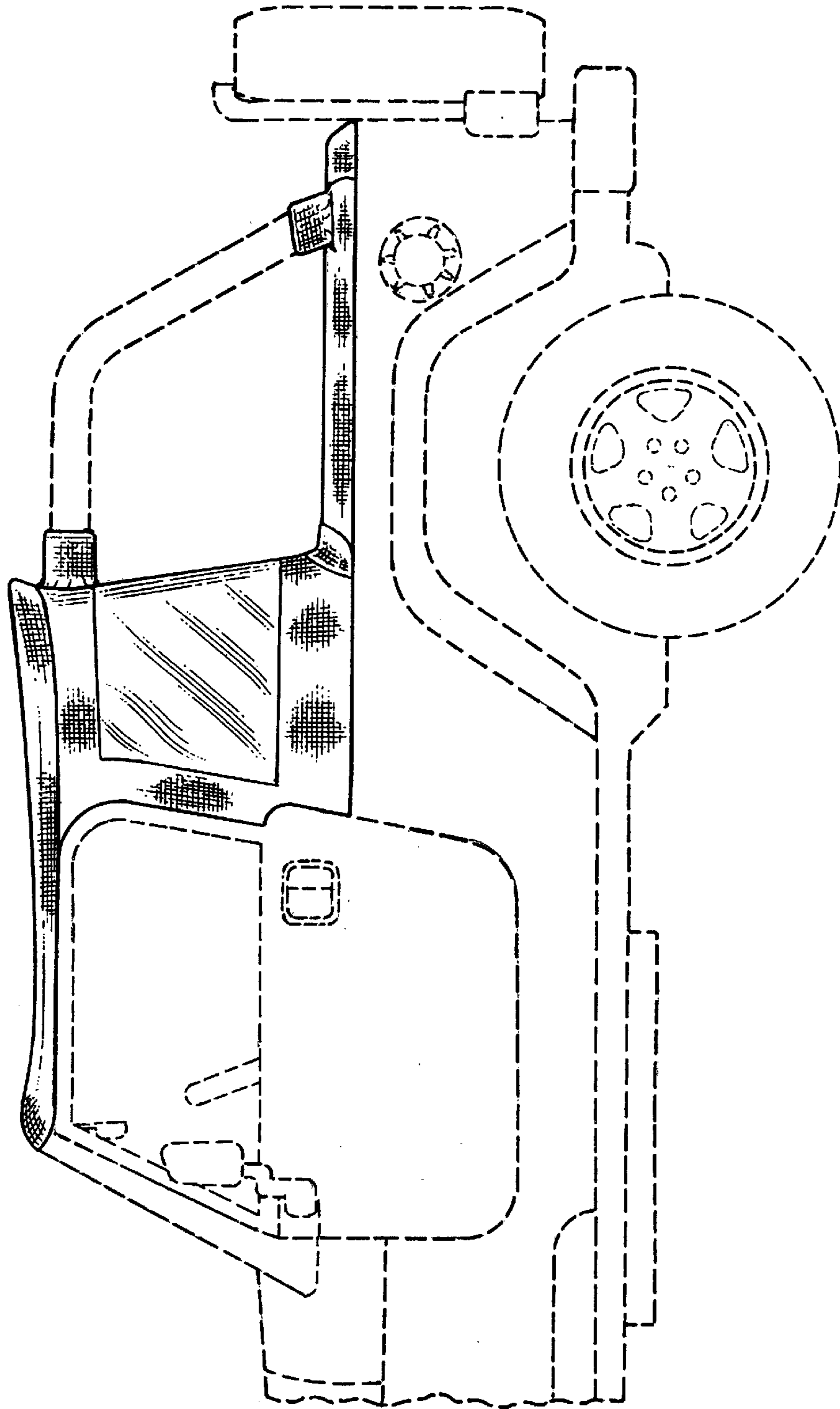

Fig. 3

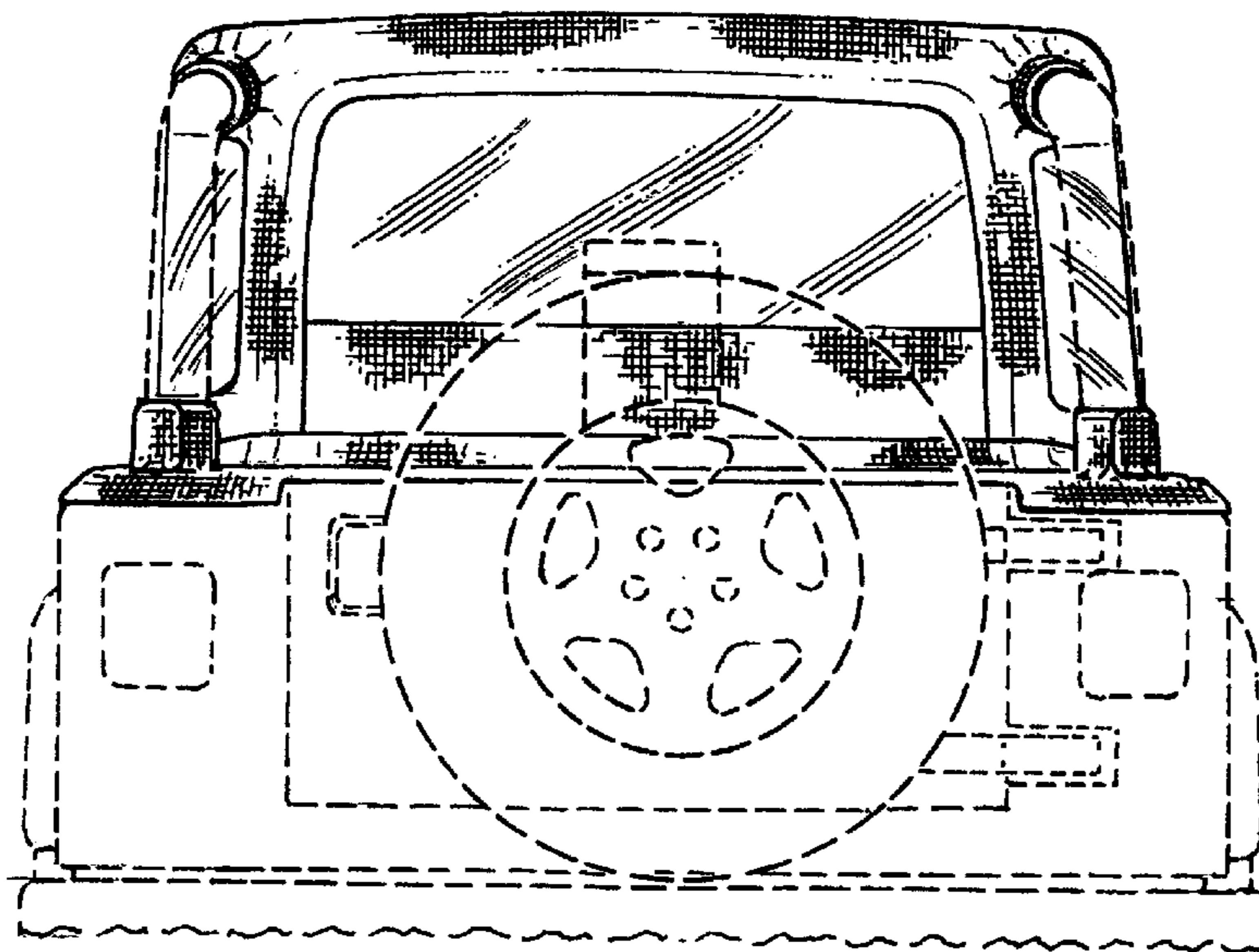
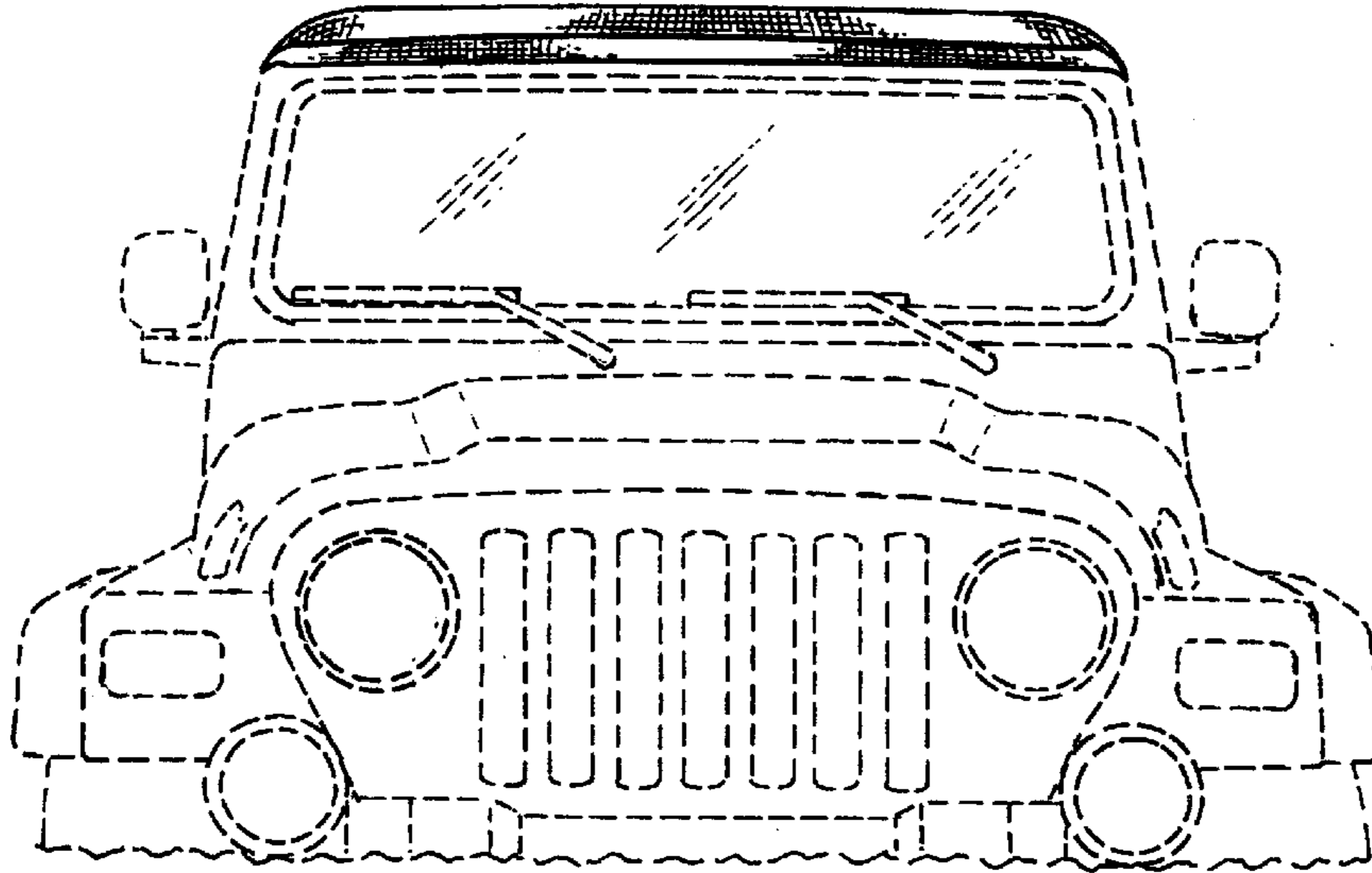

Fig. 4

Fig. 5

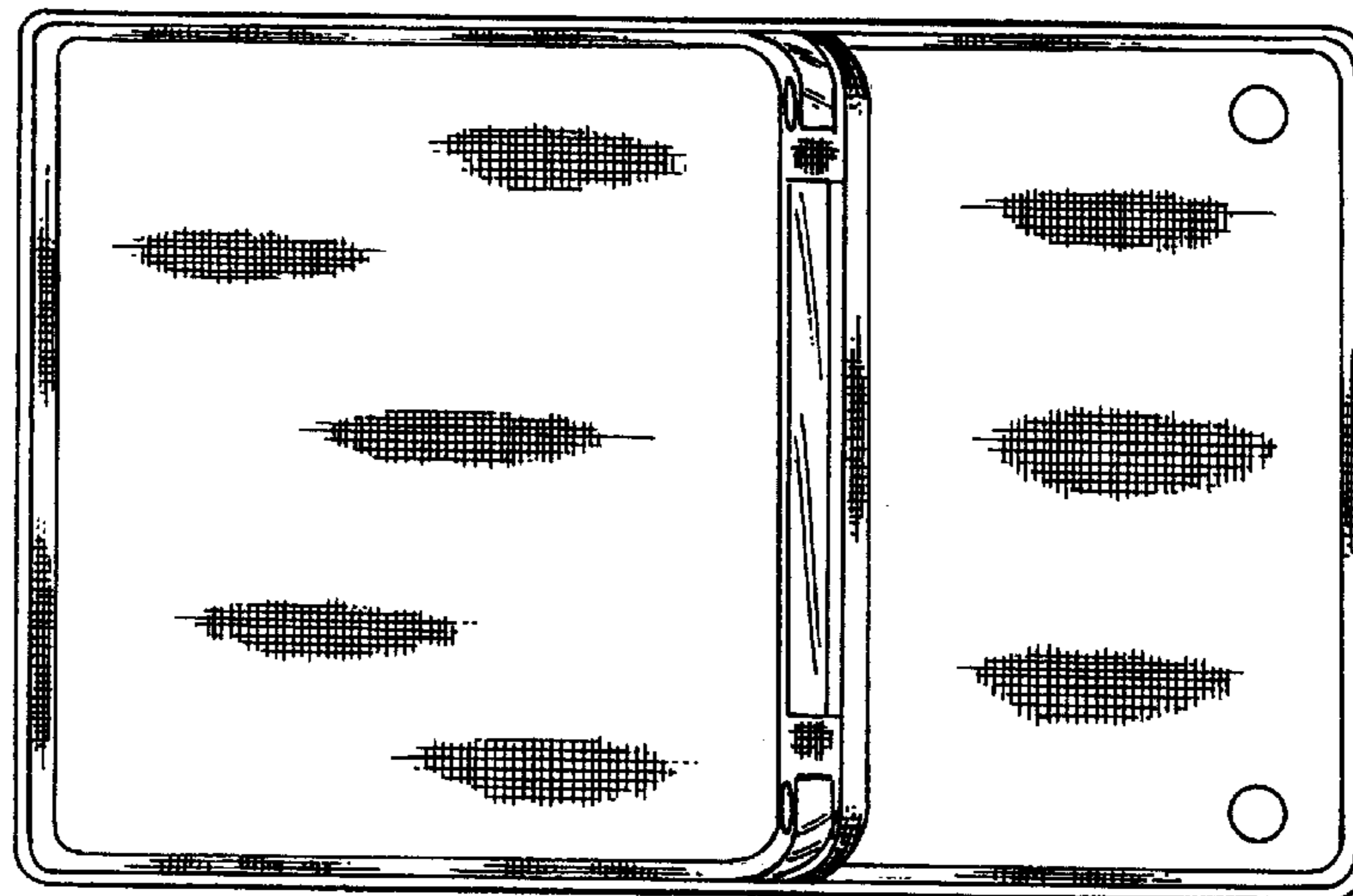
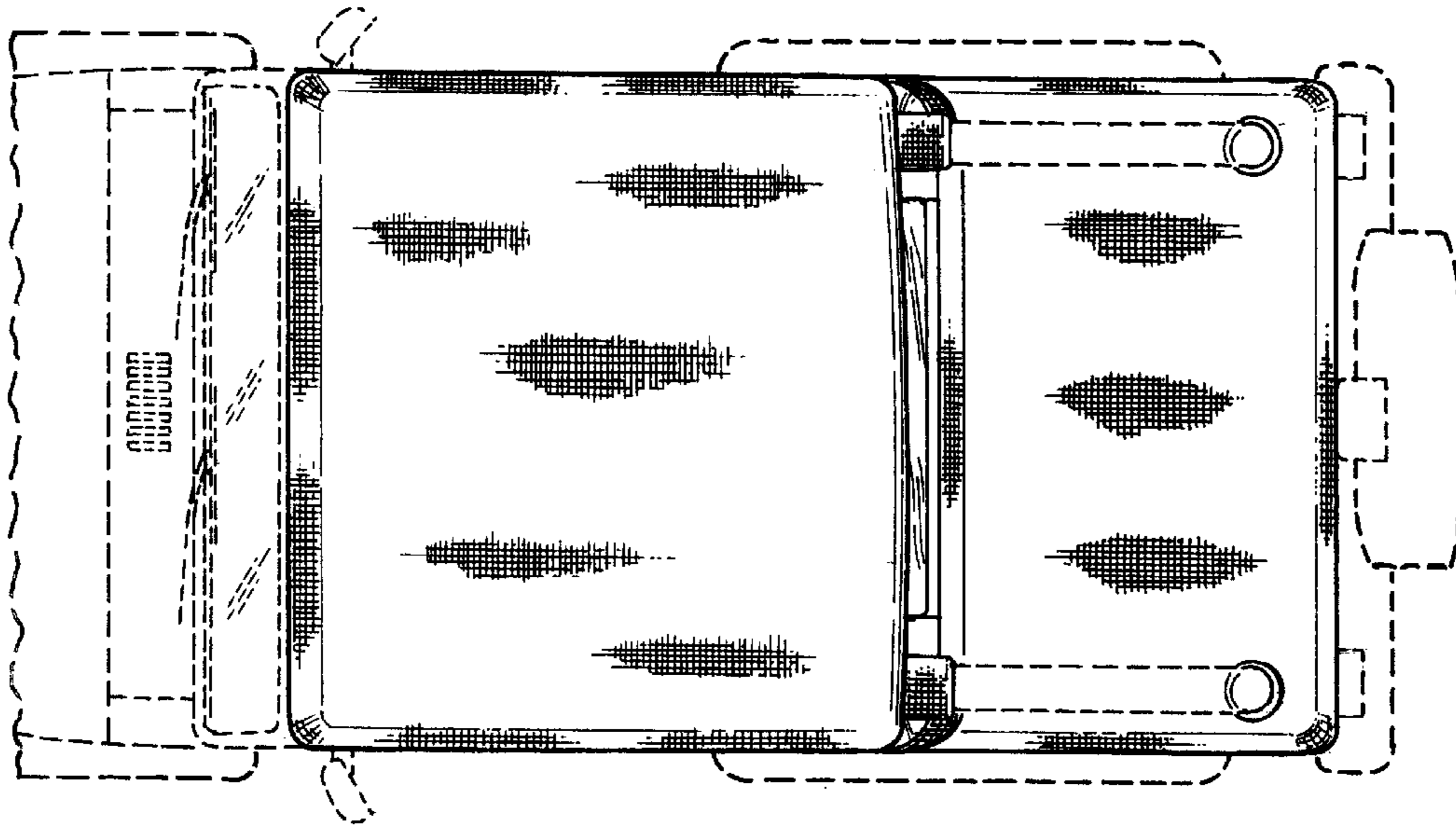

Fig. 6

Fig. 7

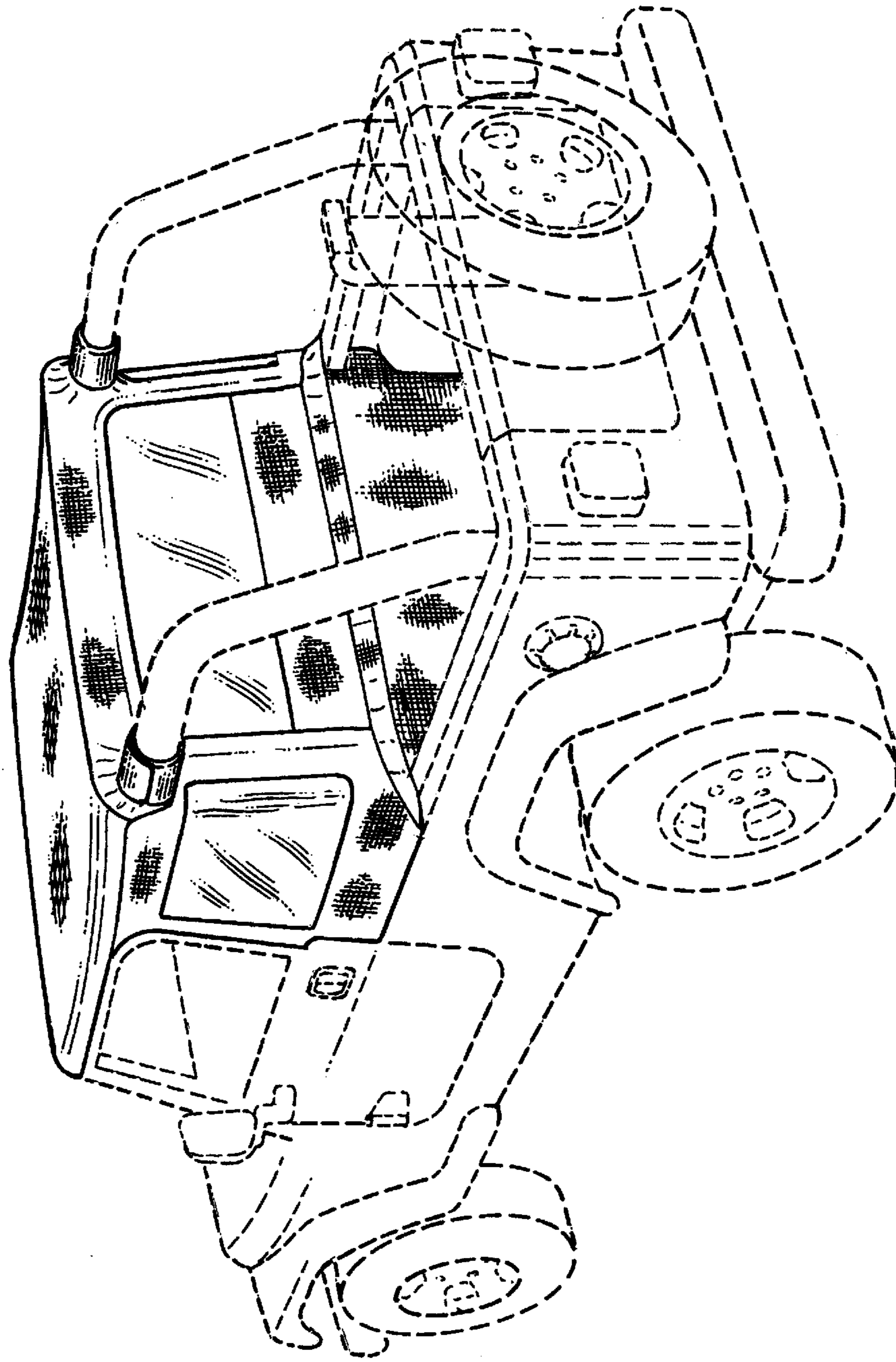

Fig. 8

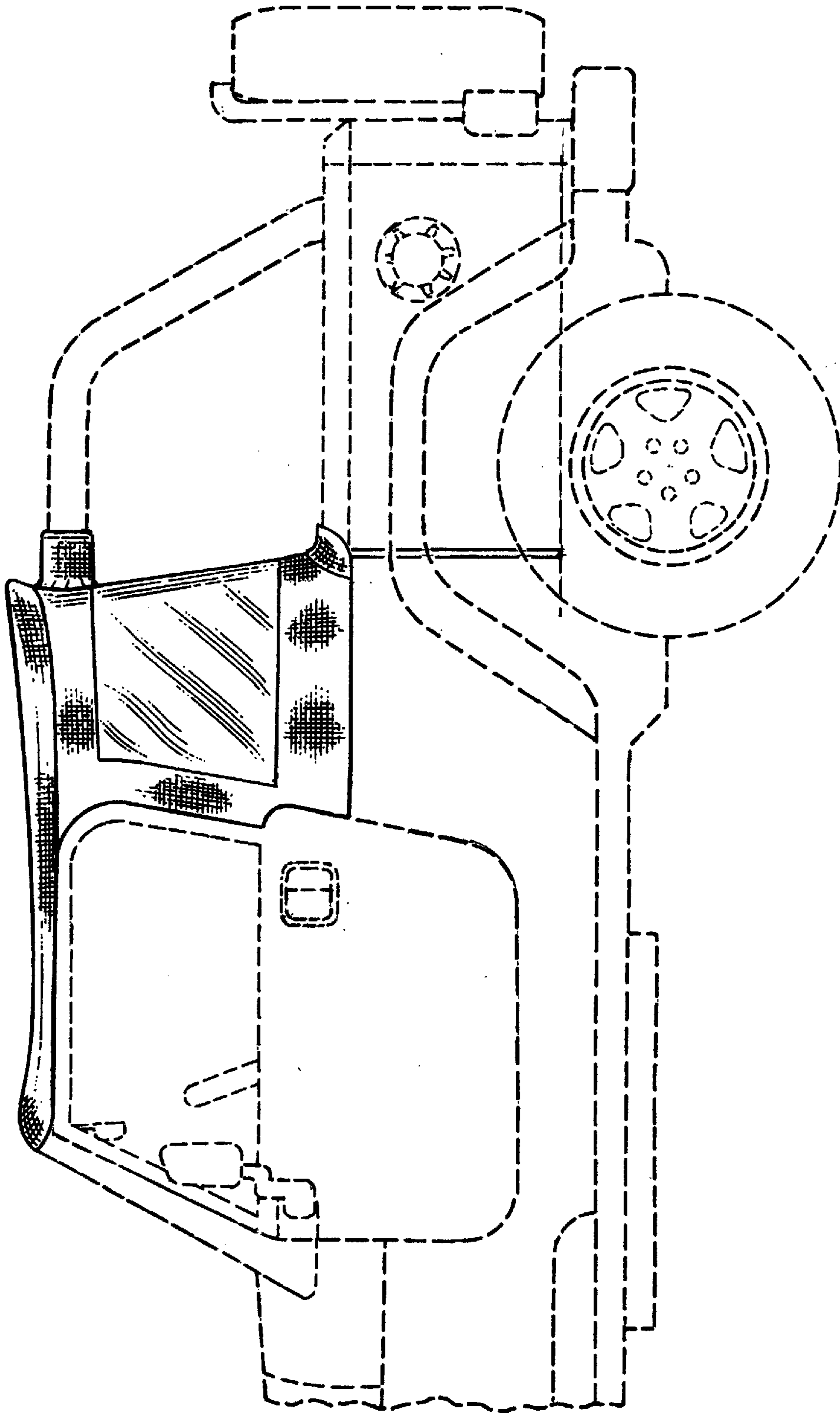

Fig. 9

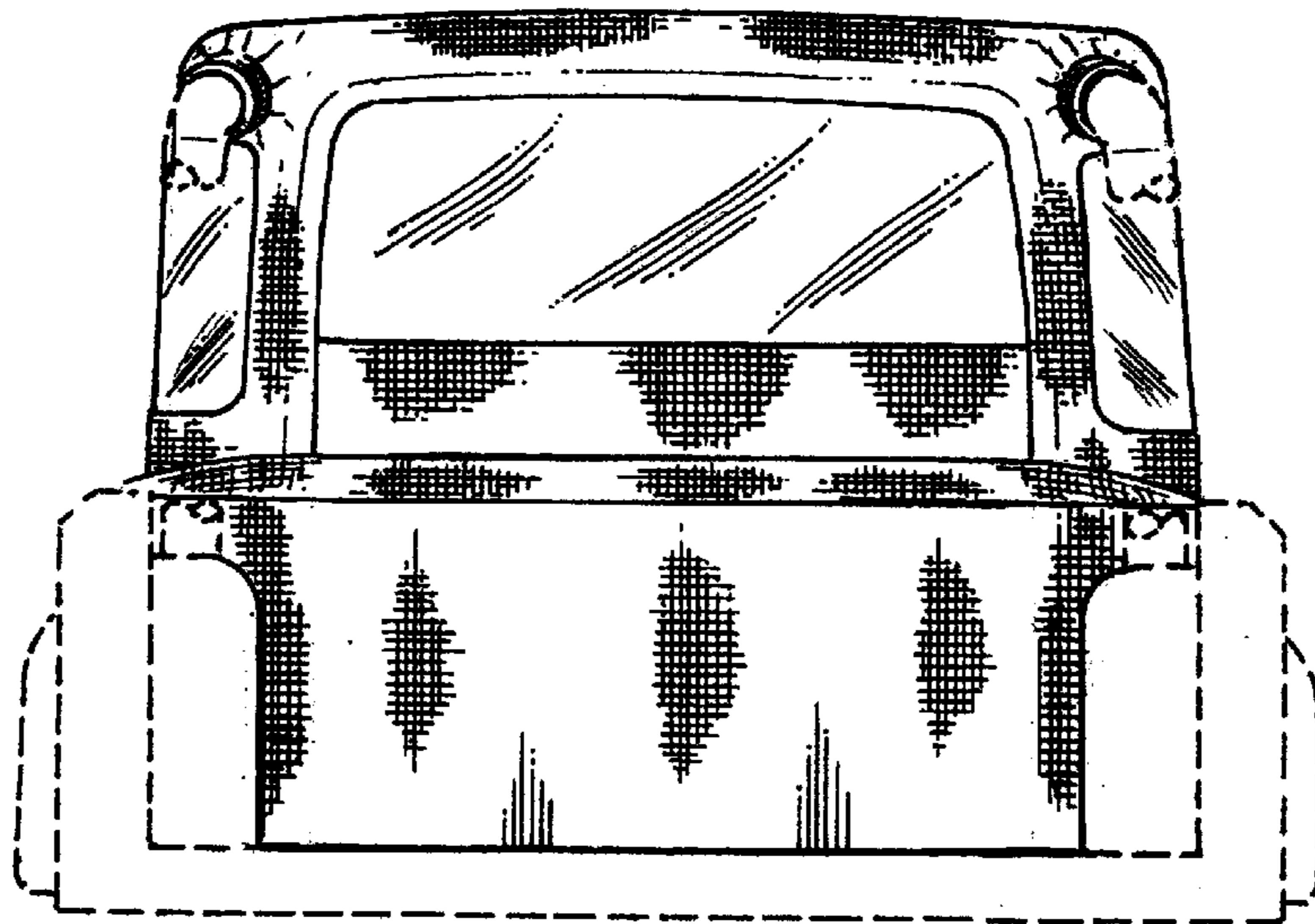
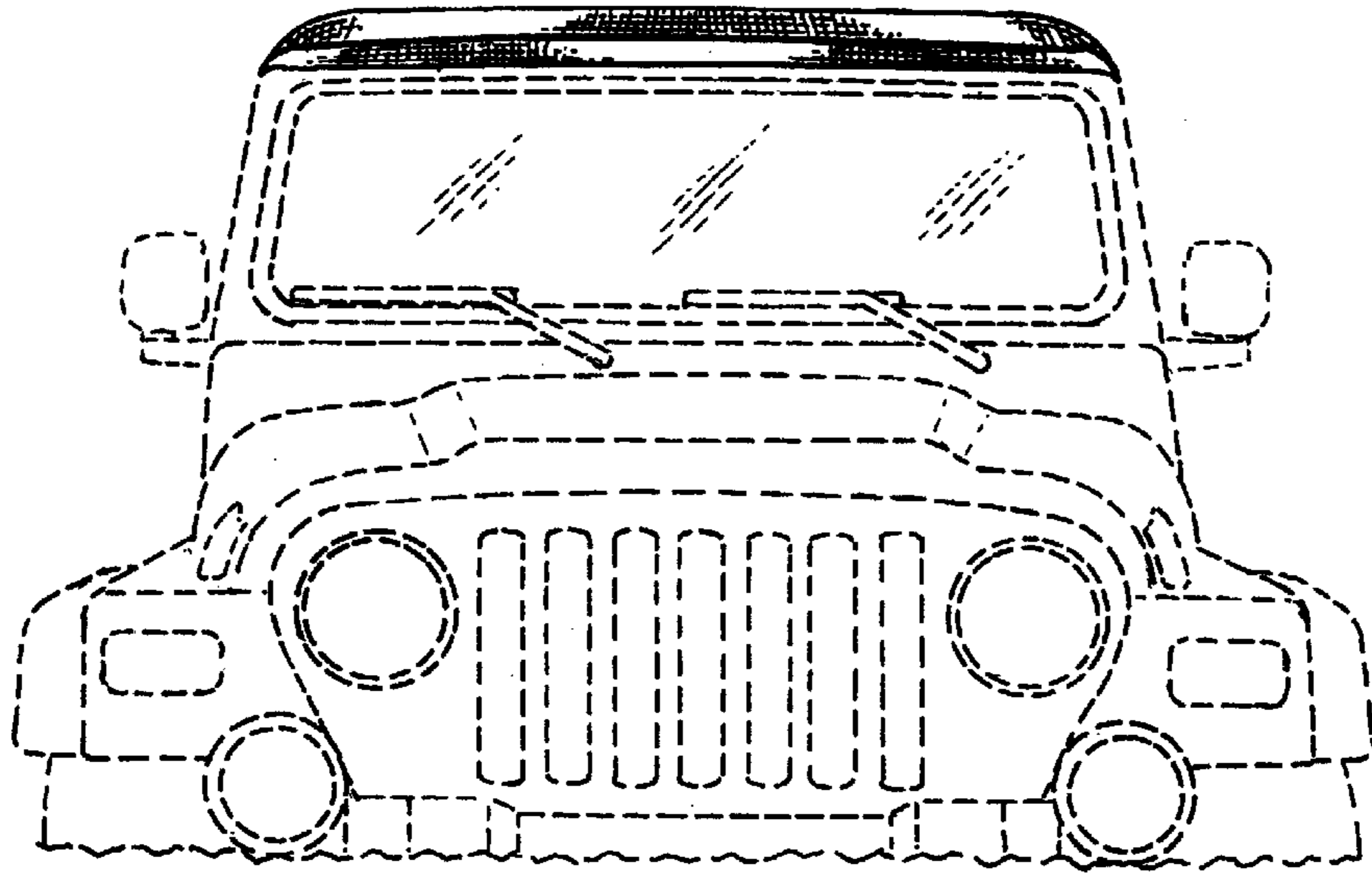

Fig. 10

Fig.11

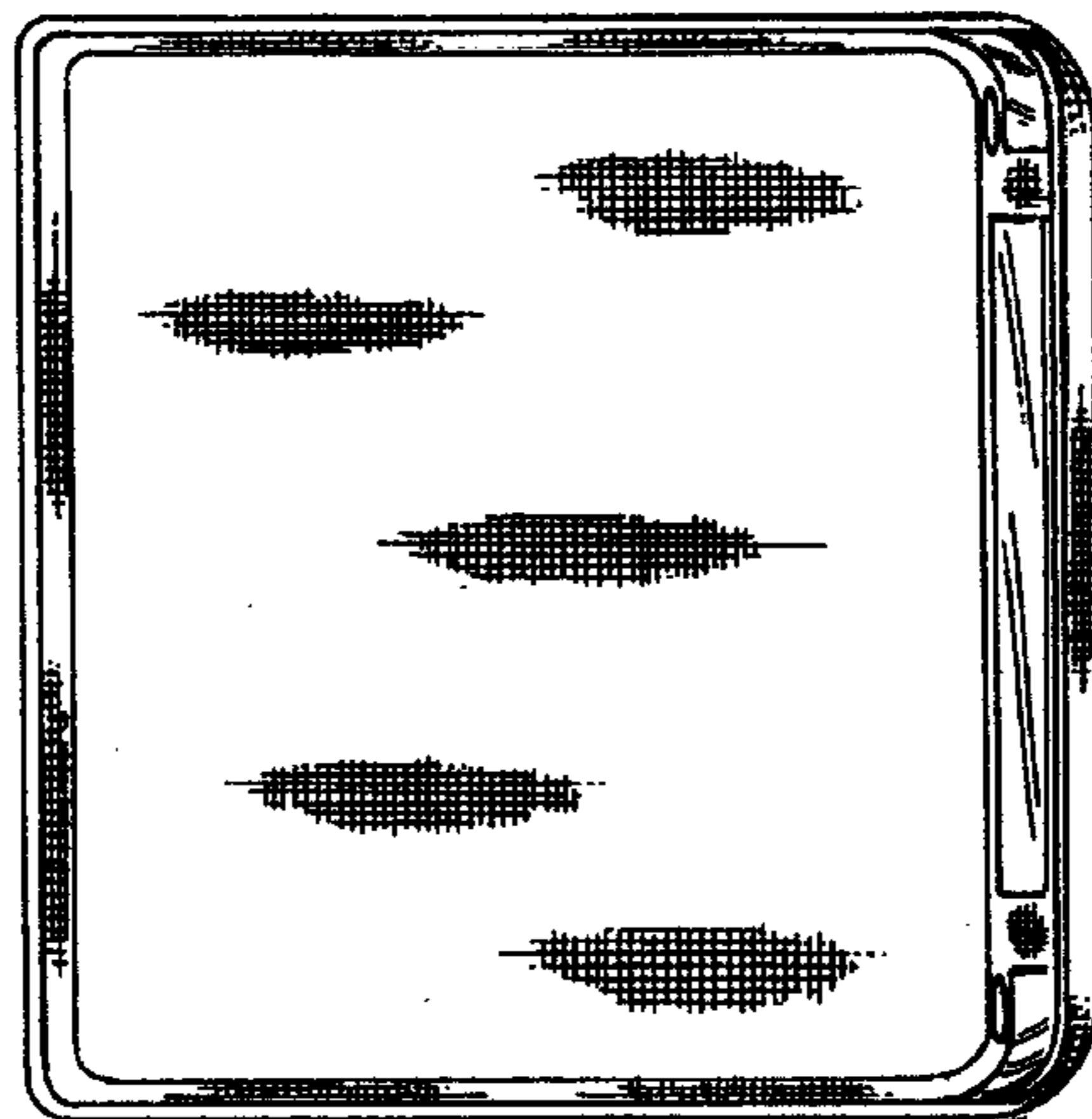
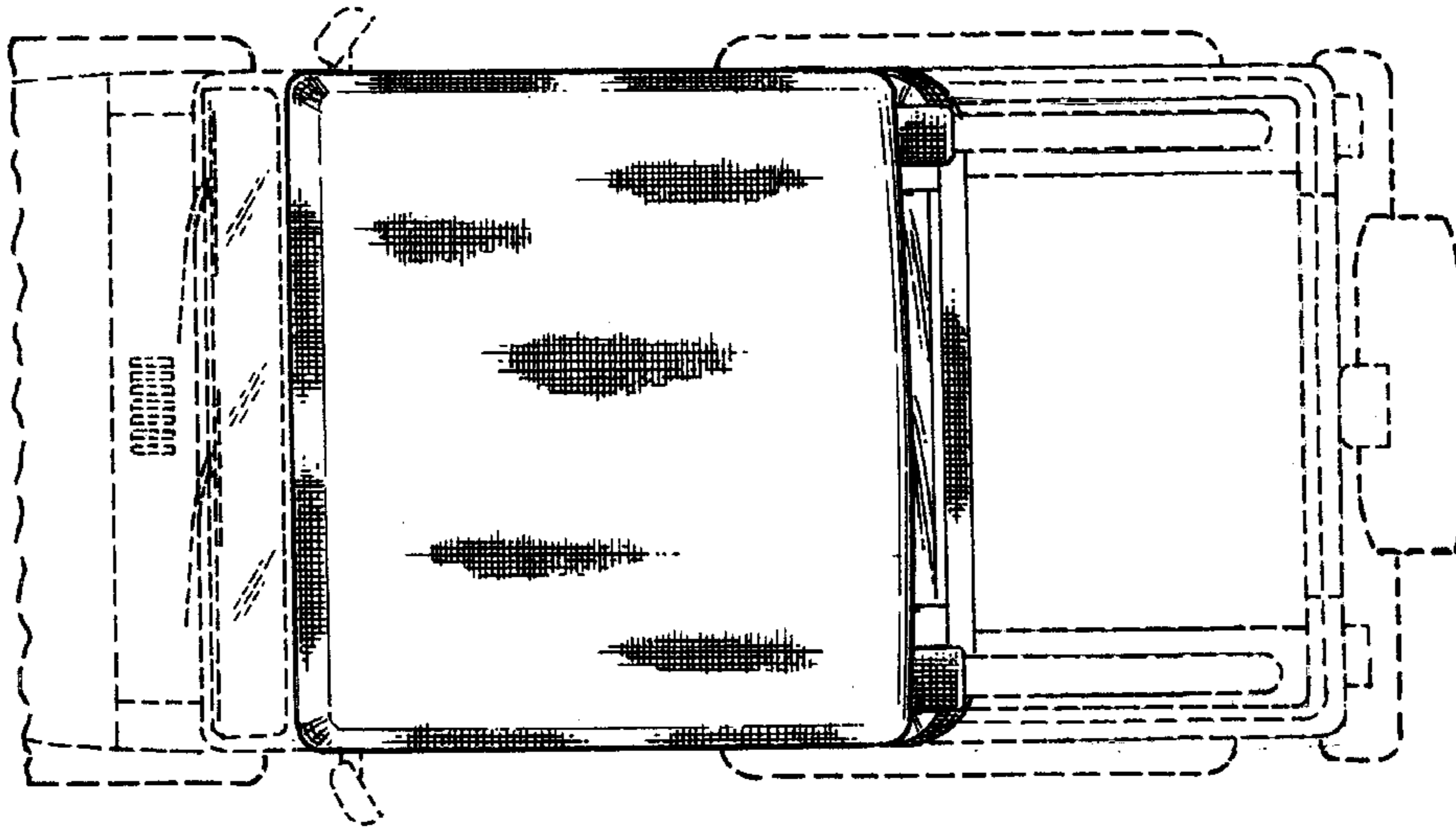

Fig.12