



US00D537029S

(12) **United States Design Patent**
Eakins et al.

(10) **Patent No.:** **US D537,029 S**

(45) **Date of Patent:** **** Feb. 20, 2007**

(54) **JET AIRPLANE**

(75) Inventors: **Mark E. Eakins**, Kirkland, WA (US);
Paul Mikulencak, Snohomish, WA
(US); **R. Blake Emery**, Renton, WA
(US); **Victor K. Stuhr**, Seattle, WA
(US); **Adam P. Malachowski**,
Lynwood, WA (US); **Stephen T.**
Brown, Everett, WA (US); **Richard K.**
Wong, Lynnwood, WA (US); **Chester**
P. Nelson, Kirkland, WA (US); **Michael**
L. Drake, Bellevue, WA (US);
Christopher A. Vegter, Bothell, WA
(US); **Bruce R. Detert**, Seattle, WA
(US); **Christopher A. Konings**,
Lynnwood, WA (US)

(73) Assignee: **The Boeing Company**, Chicago, IL
(US)

(**) Term: **14 Years**

(21) Appl. No.: **29/236,421**

(22) Filed: **Aug. 16, 2005**

Related U.S. Application Data

(63) Continuation-in-part of application No. 29/220,255, filed on
Dec. 28, 2004, now Pat. No. Des. 515,012.

(51) **LOC (8) Cl.** **12-12**

(52) **U.S. Cl.** **D12/319**

(58) **Field of Classification Search** D12/319-345;
244/35 R, 45 R, 118.5, 119, 130

See application file for complete search history.

(56) **References Cited**

U.S. PATENT DOCUMENTS

| | | | | |
|------------|---|---------|----------------------|---------|
| D354,474 S | * | 1/1995 | Murphy et al. | D12/340 |
| D491,875 S | * | 6/2004 | Eatkins et al. | D12/319 |
| D495,653 S | * | 9/2004 | Eatkins et al. | D12/319 |
| D499,688 S | * | 12/2004 | Atkinson et al. | D12/319 |
| D500,980 S | * | 1/2005 | Eatkins et al. | D12/319 |
| D515,012 S | * | 2/2006 | Eatkins et al. | D12/319 |
| D516,995 S | * | 3/2006 | Eatkins et al. | D12/319 |

* cited by examiner

Primary Examiner—Marcus A. Jackson

(74) *Attorney, Agent, or Firm*—Ostrager Chong Flaherty &
Broitman P.C.

(57) **CLAIM**

The ornamental design for a jet airplane, as shown and
described.

DESCRIPTION

FIG. 1 is a top plan view of the jet airplane;
FIG. 2 is a view of one side of the jet airplane, with the
opposite side being a mirror image thereof;
FIG. 3 is a front plan view of the jet airplane;
FIG. 4 is a back plan view of the jet airplane; and,
FIG. 5 is a bottom plan view of the jet airplane.

1 Claim, 3 Drawing Sheets

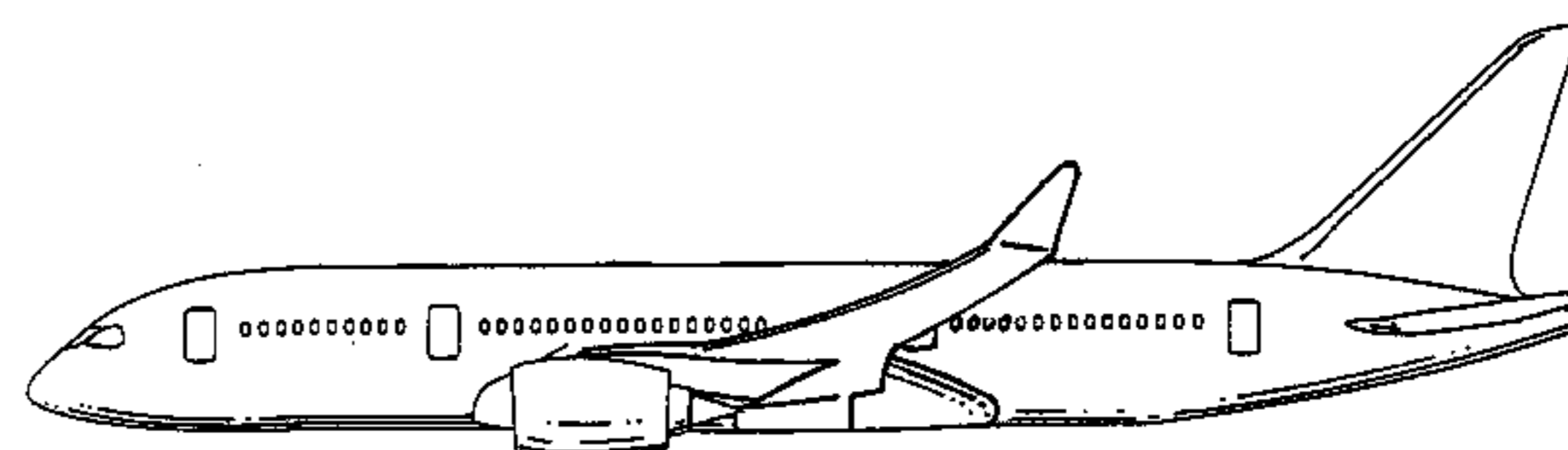
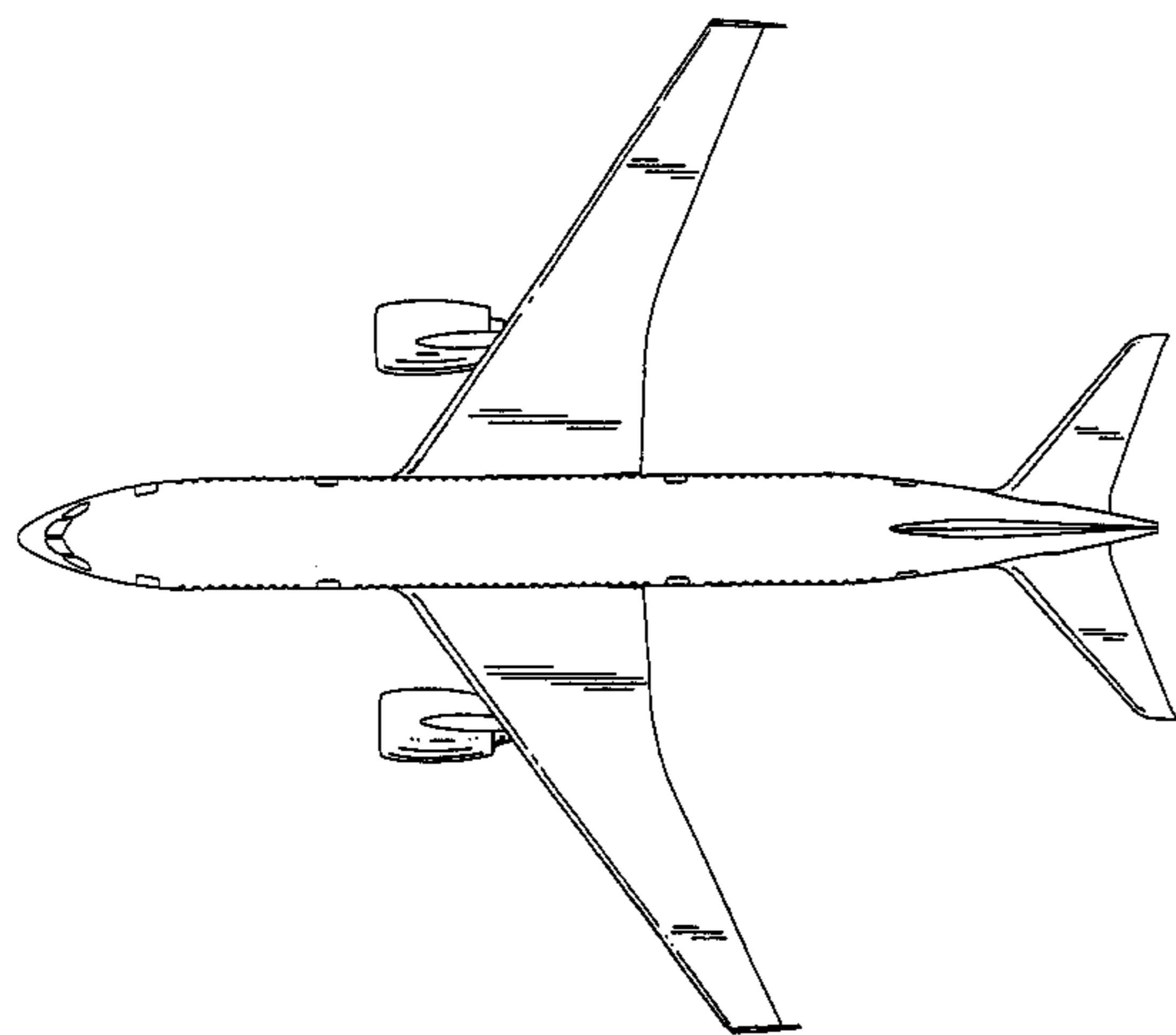

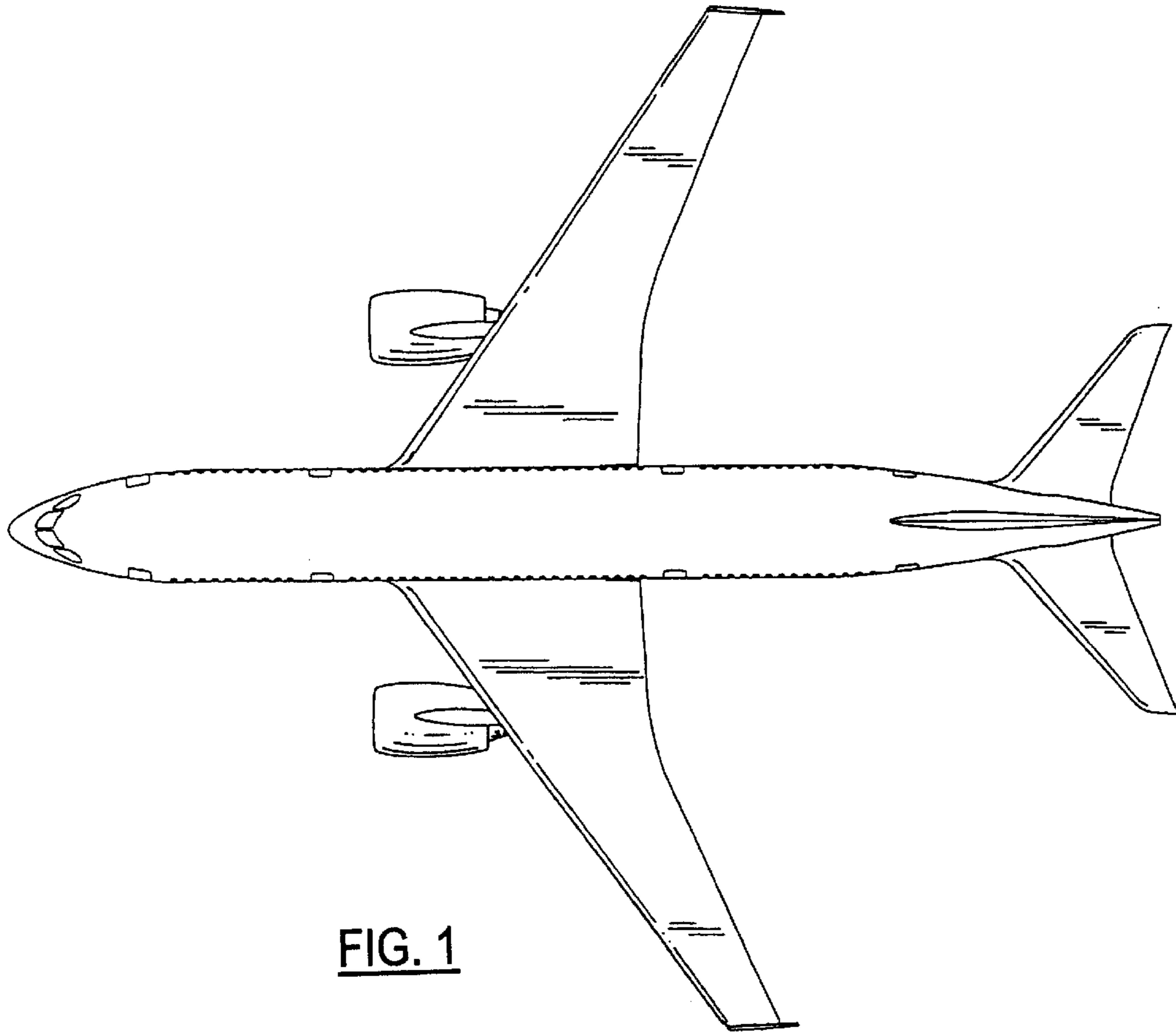

FIG. 1

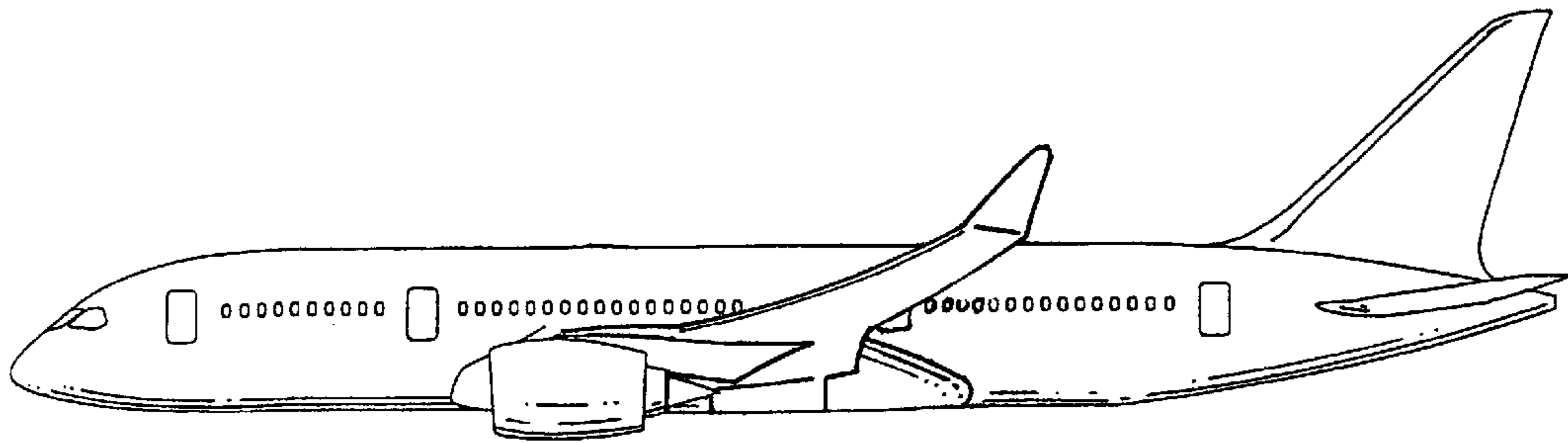

FIG. 2

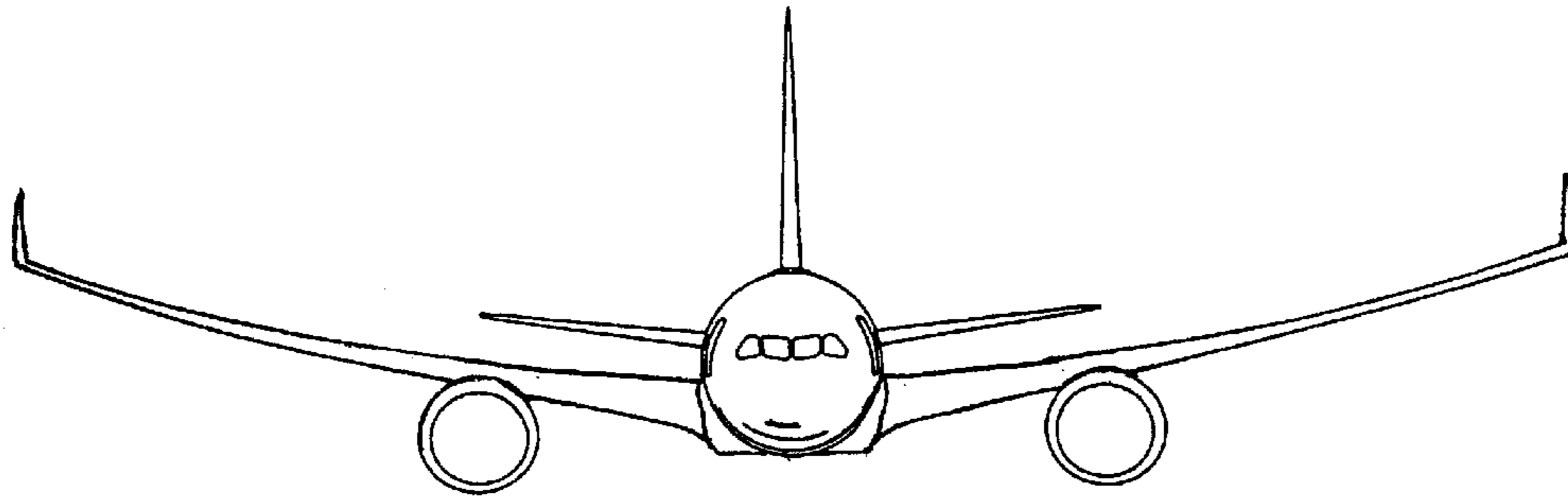

FIG. 3

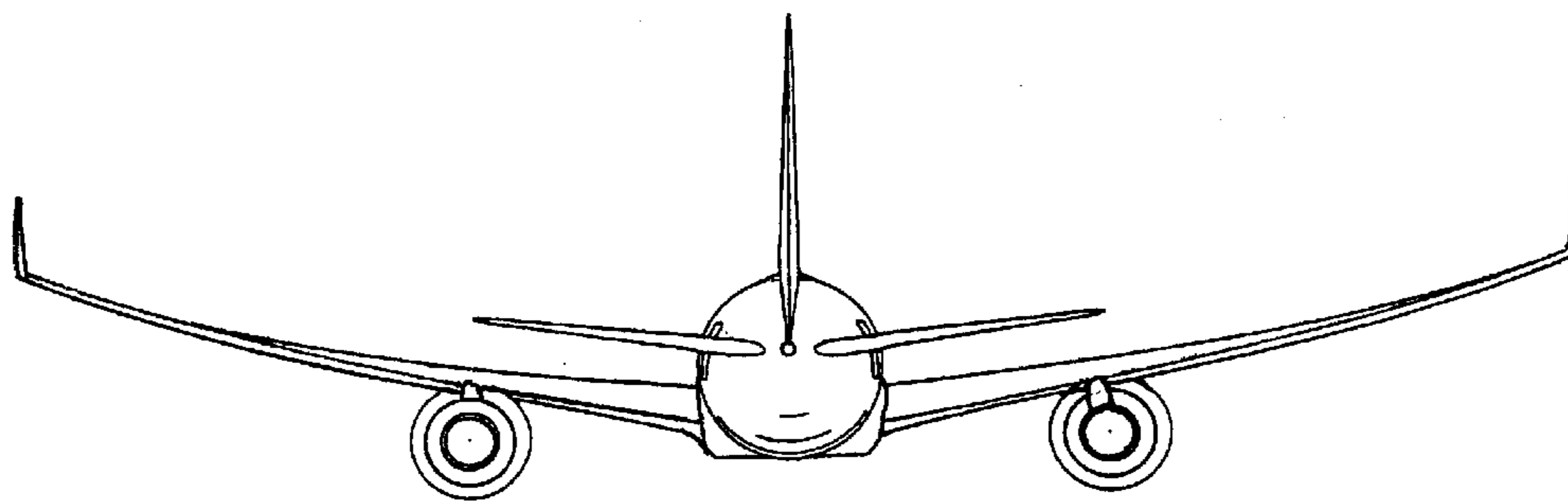

FIG. 4

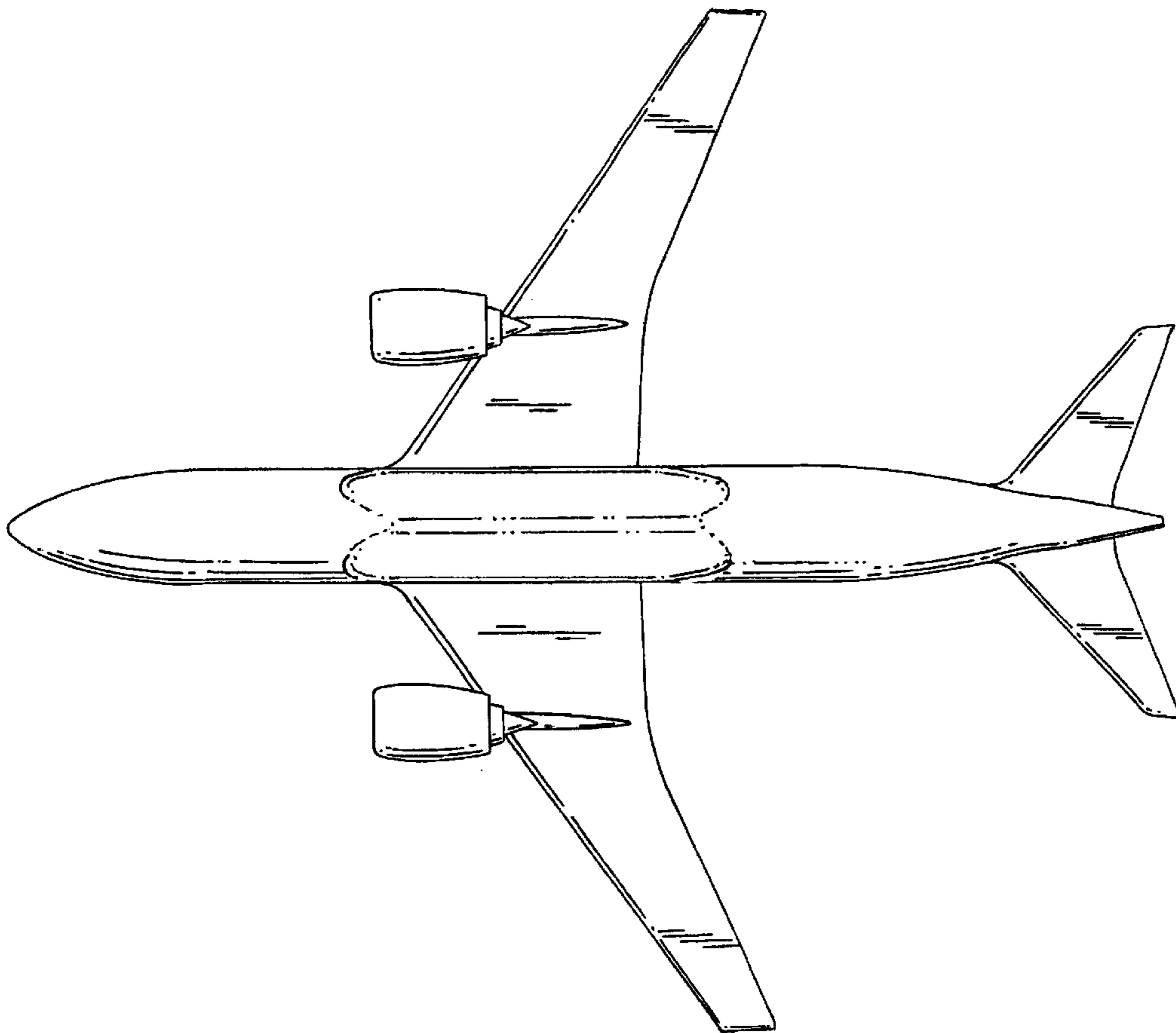

FIG. 5