



US00D536808S

(12) **United States Design Patent**
Hsu

(10) **Patent No.:** **US D536,808 S**

(45) **Date of Patent:** **** Feb. 13, 2007**

(54) **VEHICLE TAIL LIGHT**

(75) Inventor: **Ricky Hsu**, Palos Verdes, CA (US)

(73) Assignee: **Honda Motor Co., Ltd.**, Tokyo (JP)

(**) Term: **14 Years**

(21) Appl. No.: **29/251,628**

(22) Filed: **Jan. 10, 2006**

(51) **LOC (8) Cl.** **26-06**

(52) **U.S. Cl.** **D26/28**

(58) **Field of Classification Search** D26/28-36;
362/157, 158, 171-174, 183-208

See application file for complete search history.

(56) **References Cited**

U.S. PATENT DOCUMENTS

D474,293 S * 5/2003 Yang D26/28

D516,233 S * 2/2006 Ikeda et al. D26/28

* cited by examiner

Primary Examiner—Marcus A. Jackson

(74) *Attorney, Agent, or Firm*—Plumsea Law Group, LLC;
Mark E. Duell

(57) **CLAIM**

The ornamental design for a vehicle tail light, as shown and described.

DESCRIPTION

FIG. 1 is a perspective view of a vehicle tail light showing my new design;

FIG. 2 is a side elevational view thereof.

FIG. 3 is a rear elevational view thereof;

FIG. 4 is a perspective view of a right-handed version of a vehicle tail light showing my new design;

FIG. 5 is a side elevational view thereof; and,

FIG. 6 is a rear elevational view thereof.

The broken line showings of the remainder of the rear end of the vehicle are for illustrative purposes only and form no part of the claimed design.

1 Claim, 2 Drawing Sheets

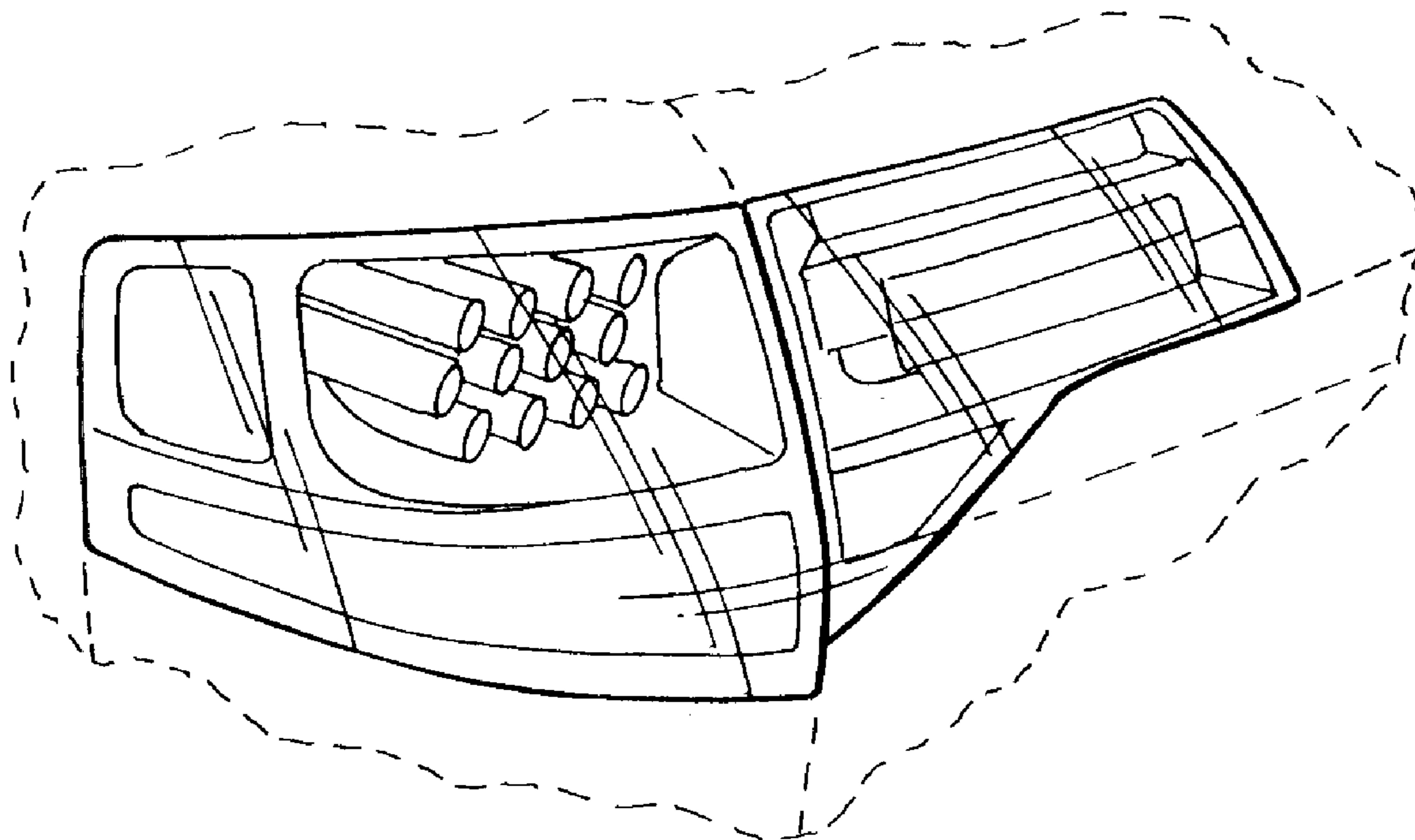

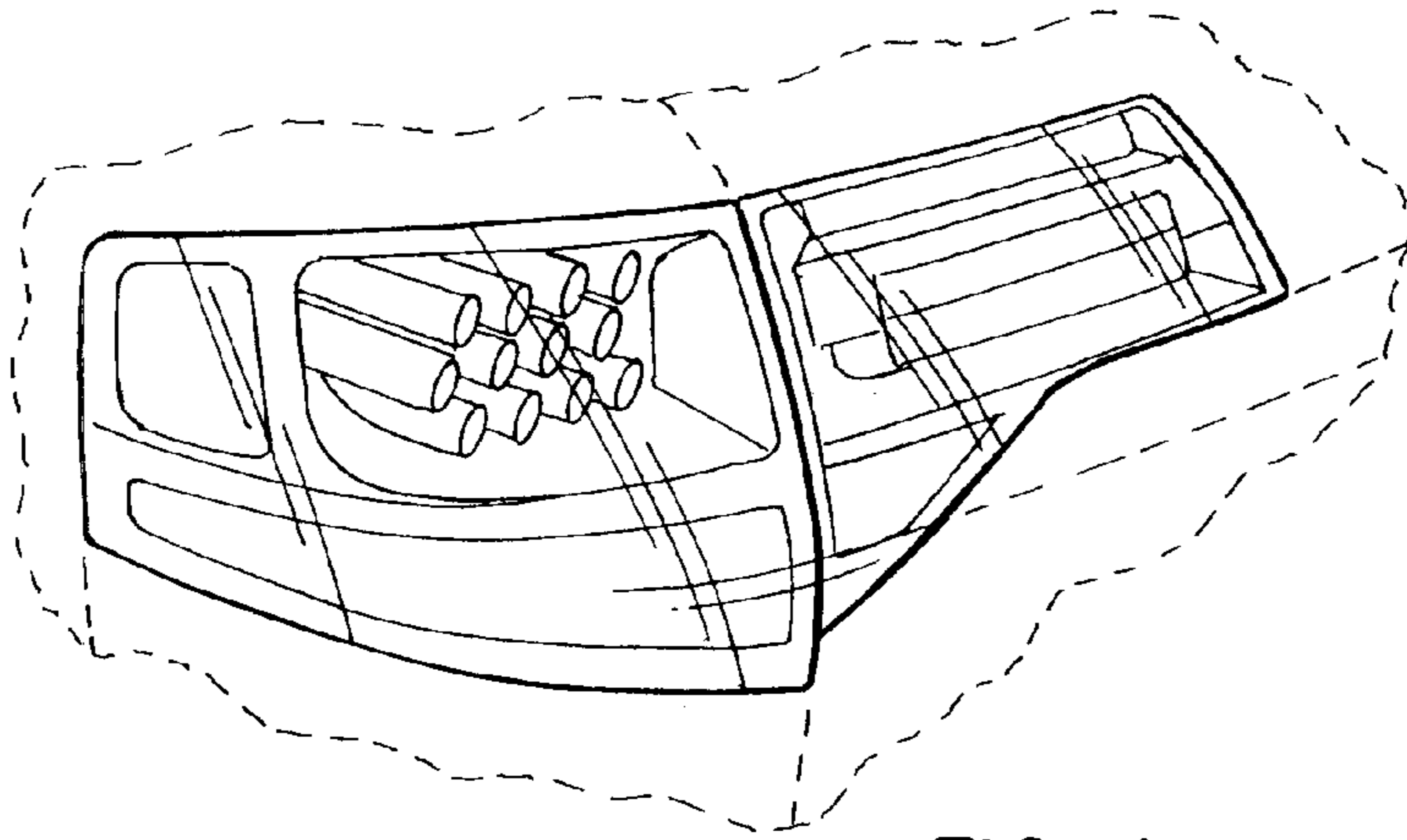

FIG. 1

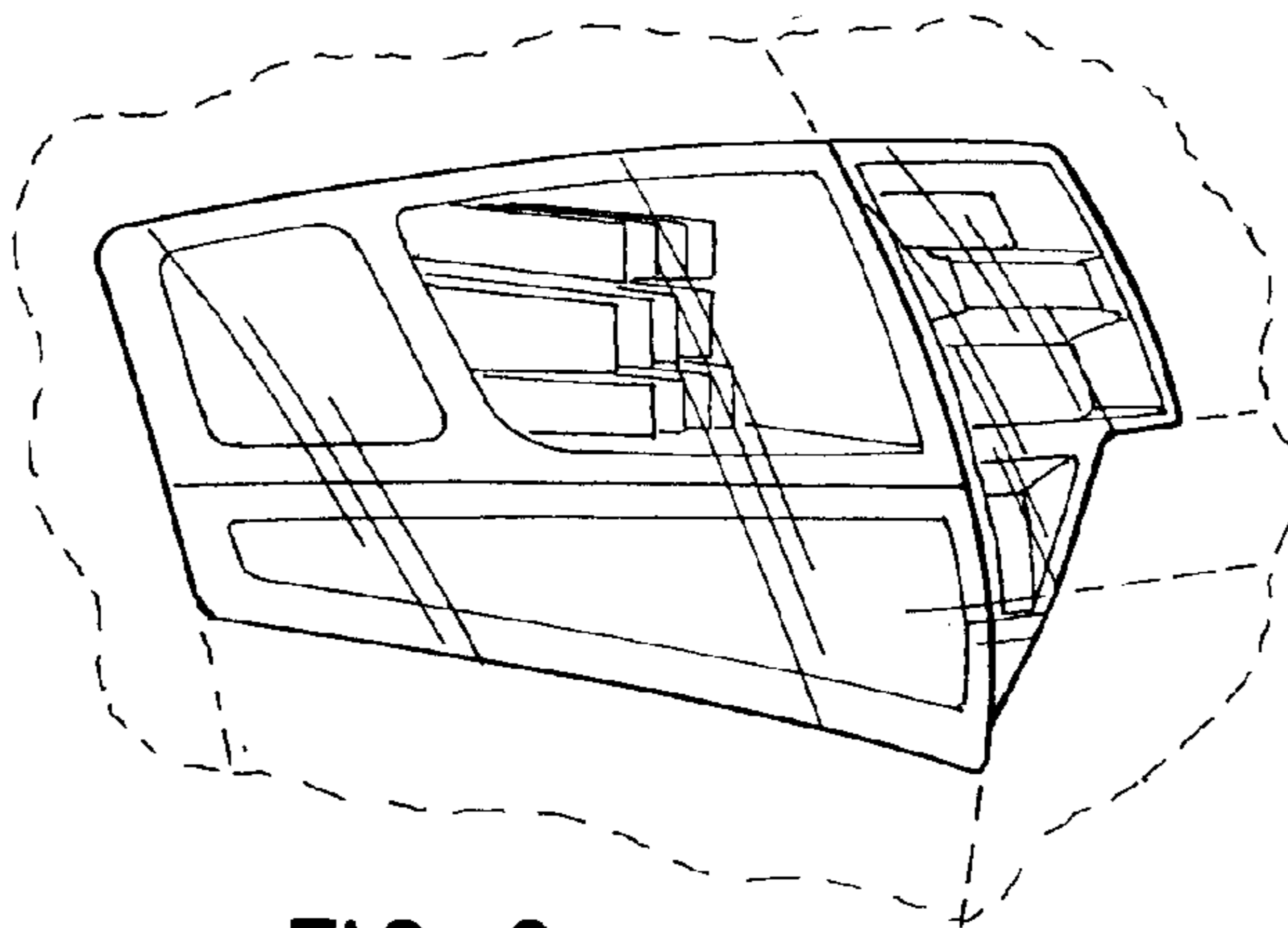

FIG. 2

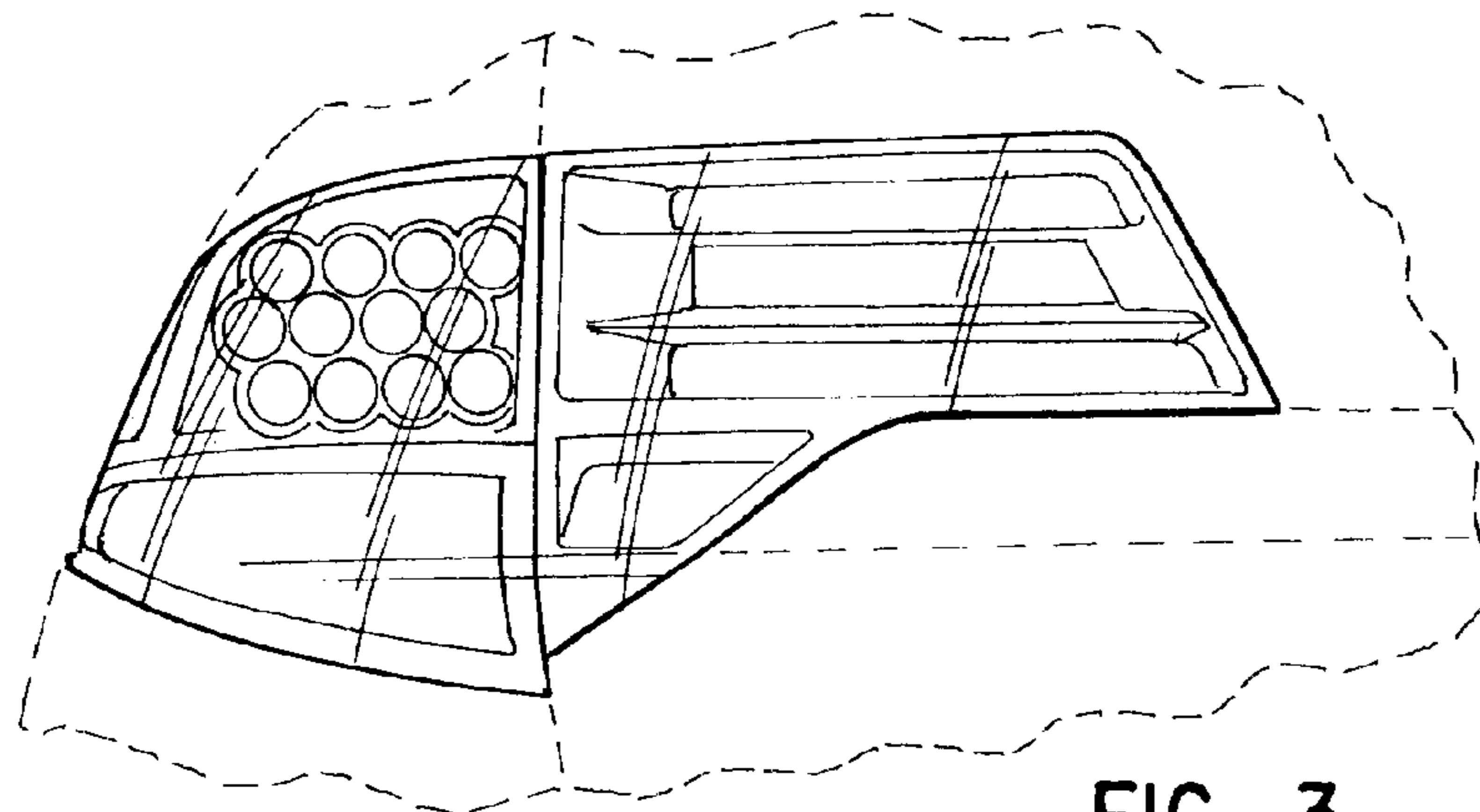

FIG. 3

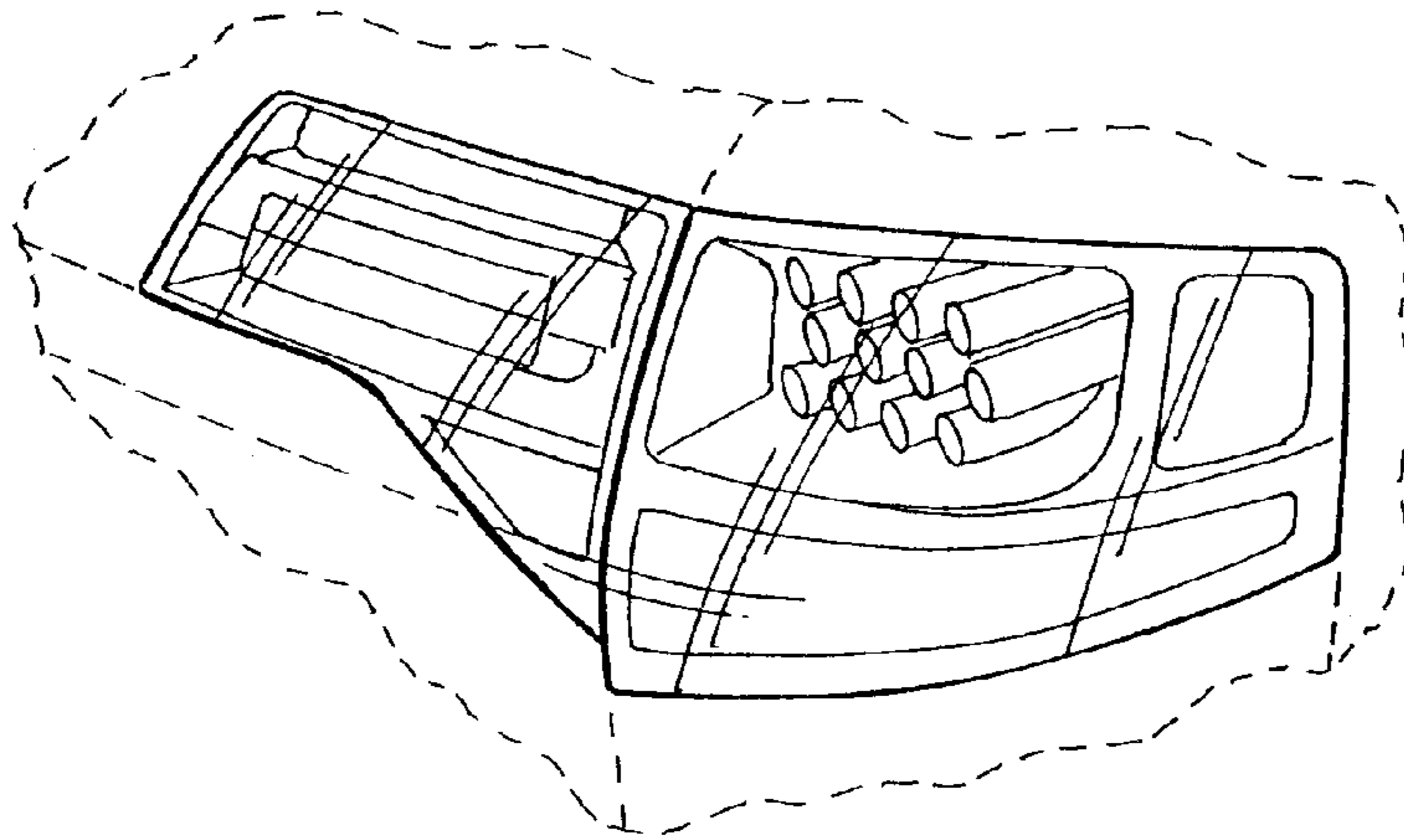

FIG. 4

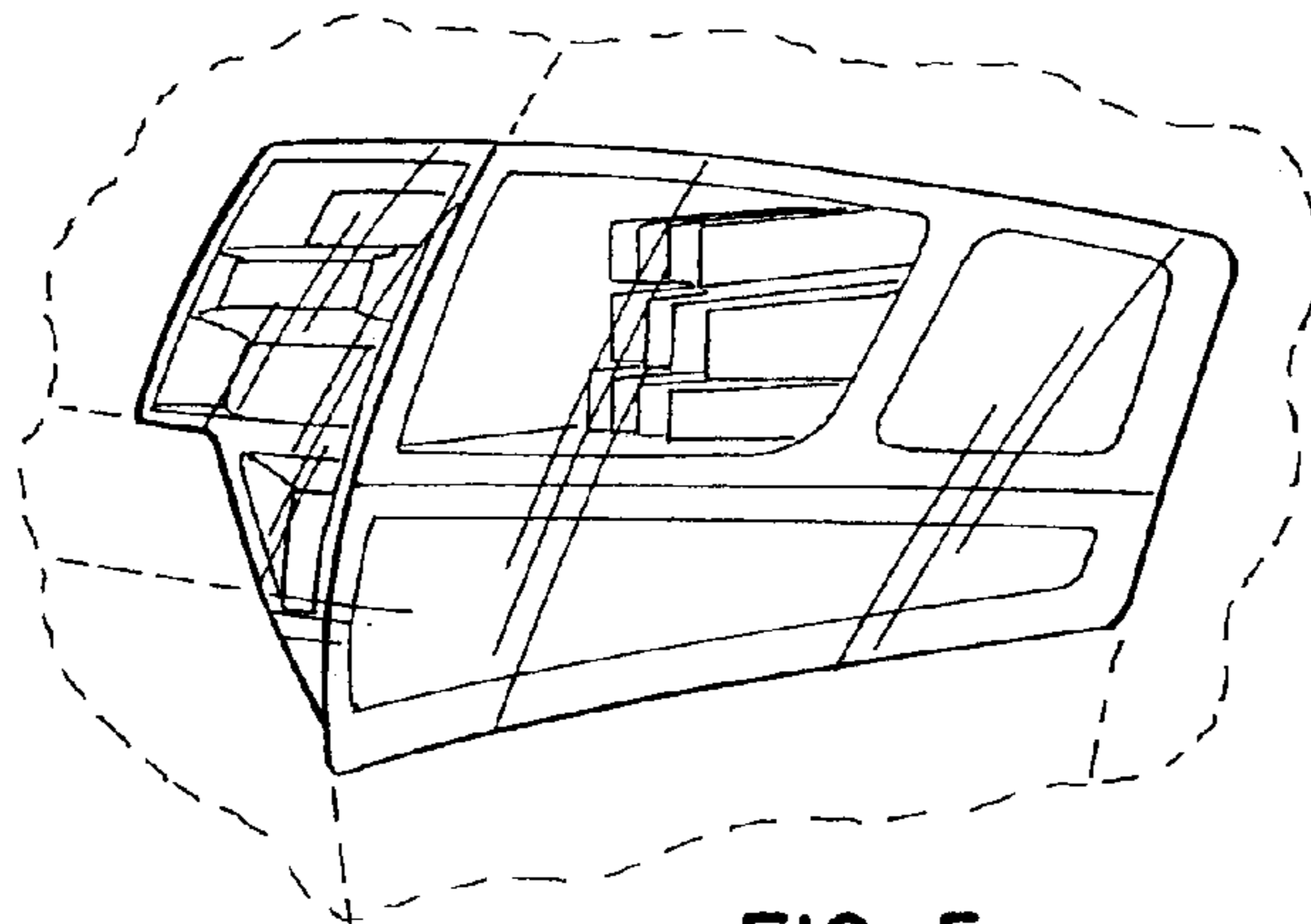

FIG. 5

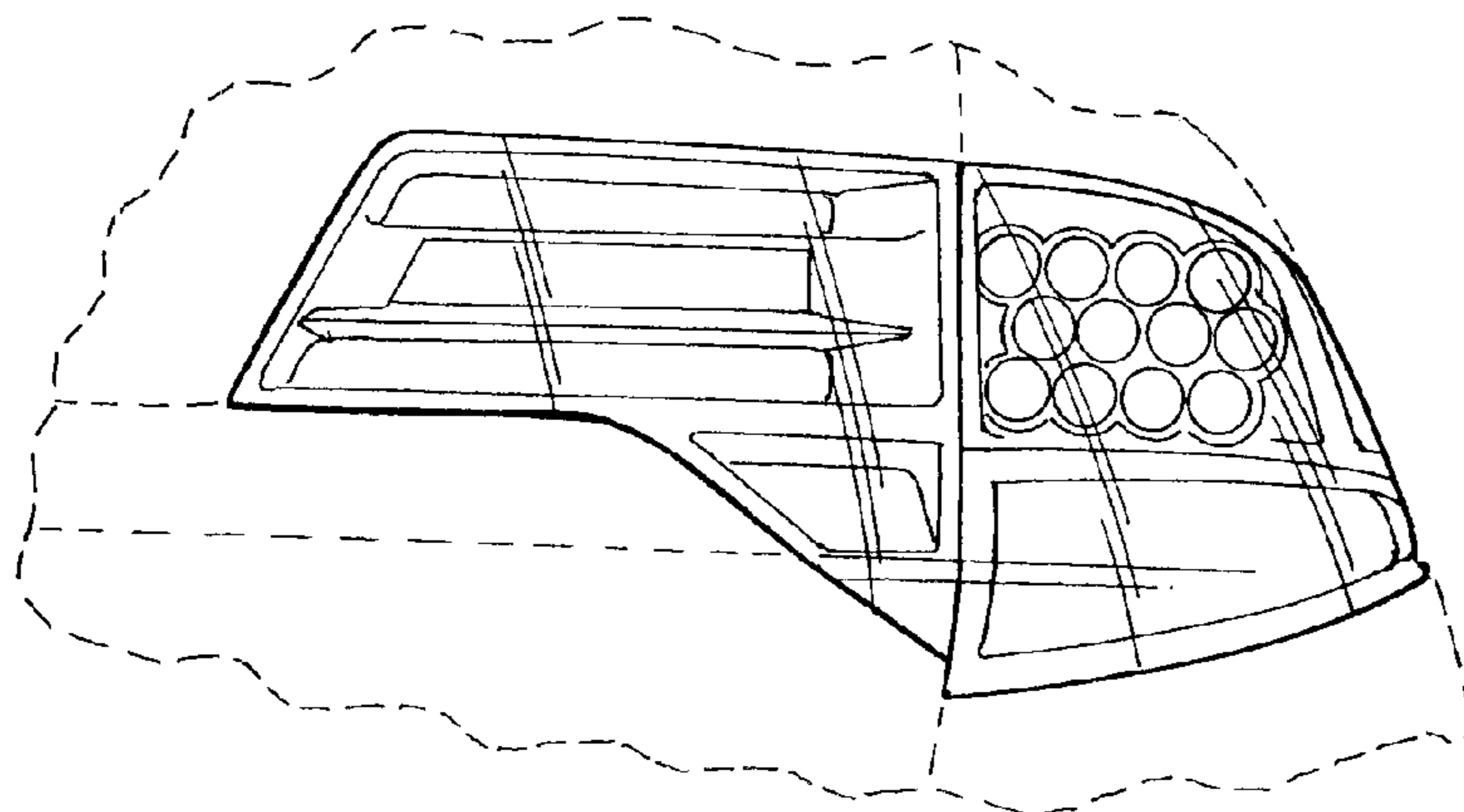

FIG. 6