



US00D536780S

(12) **United States Design Patent**
Lerche et al.

(10) **Patent No.:** **US D536,780 S**
(45) **Date of Patent:** **** Feb. 13, 2007**

(54) **VENTILATION APPARATUS**

(75) Inventors: **Ulrich Lerche**, Michelfeld (DE);
Robert Dent, Schwabisch Hall (DE)

(73) Assignee: **Stego-Holding GmbH**, Schwäbisch
Hall (DE)

(**) Term: **14 Years**

(21) Appl. No.: **29/235,365**

(22) Filed: **Aug. 1, 2005**

(30) **Foreign Application Priority Data**

Feb. 9, 2005 (EM) 000292933-0001/0006

(51) **LOC (8) Cl.** **23-04**

(52) **U.S. Cl.** **D23/393**

(58) **Field of Classification Search** 237/77,
237/78 R, 78 A; D23/393, 388, 386, 317,
D23/325, 326, 328, 342, 355, 356, 359, 360,
D23/364, 366, 370, 353, 351, 335; 454/193,
454/198

See application file for complete search history.

(56) **References Cited**

U.S. PATENT DOCUMENTS

D223,918 S * 6/1972 Gray D23/335
D282,101 S * 1/1986 Yuen D23/328
D282,102 S * 1/1986 Yuen D23/328
D291,350 S * 8/1987 Sherman et al. D23/335

D296,467 S * 6/1988 Wen-Ying D23/335
D312,683 S * 12/1990 Brookshire et al. D23/335
D313,069 S * 12/1990 McCormick D23/335
D327,946 S * 7/1992 Barre D23/328
D340,971 S * 11/1993 Pirro D23/335
D354,803 S * 1/1995 Huang D23/328
D367,525 S * 2/1996 Gruebel D23/351
D377,974 S * 2/1997 Wasser D23/364
D402,741 S * 12/1998 Chen D23/335

* cited by examiner

Primary Examiner—Louis Zarfaz
Assistant Examiner—David Muller

(74) *Attorney, Agent, or Firm*—Akin Gump Strauss Hauer
& Feld, LLP

(57) **CLAIM**

The ornamental design for a ventilation apparatus, as shown
and described.

DESCRIPTION

FIG. 1 is an upper side perspective view of a ventilation
apparatus in accordance with our new design;
FIG. 2 is a front elevation view thereof;
FIG. 3 a rear elevation view thereof;
FIG. 4 is a right-side elevation view thereof;
FIG. 5 is a left-side elevation view thereof;
FIG. 6 is a top plan view thereof; and,
FIG. 7 is a bottom plan view thereof.

1 Claim, 7 Drawing Sheets

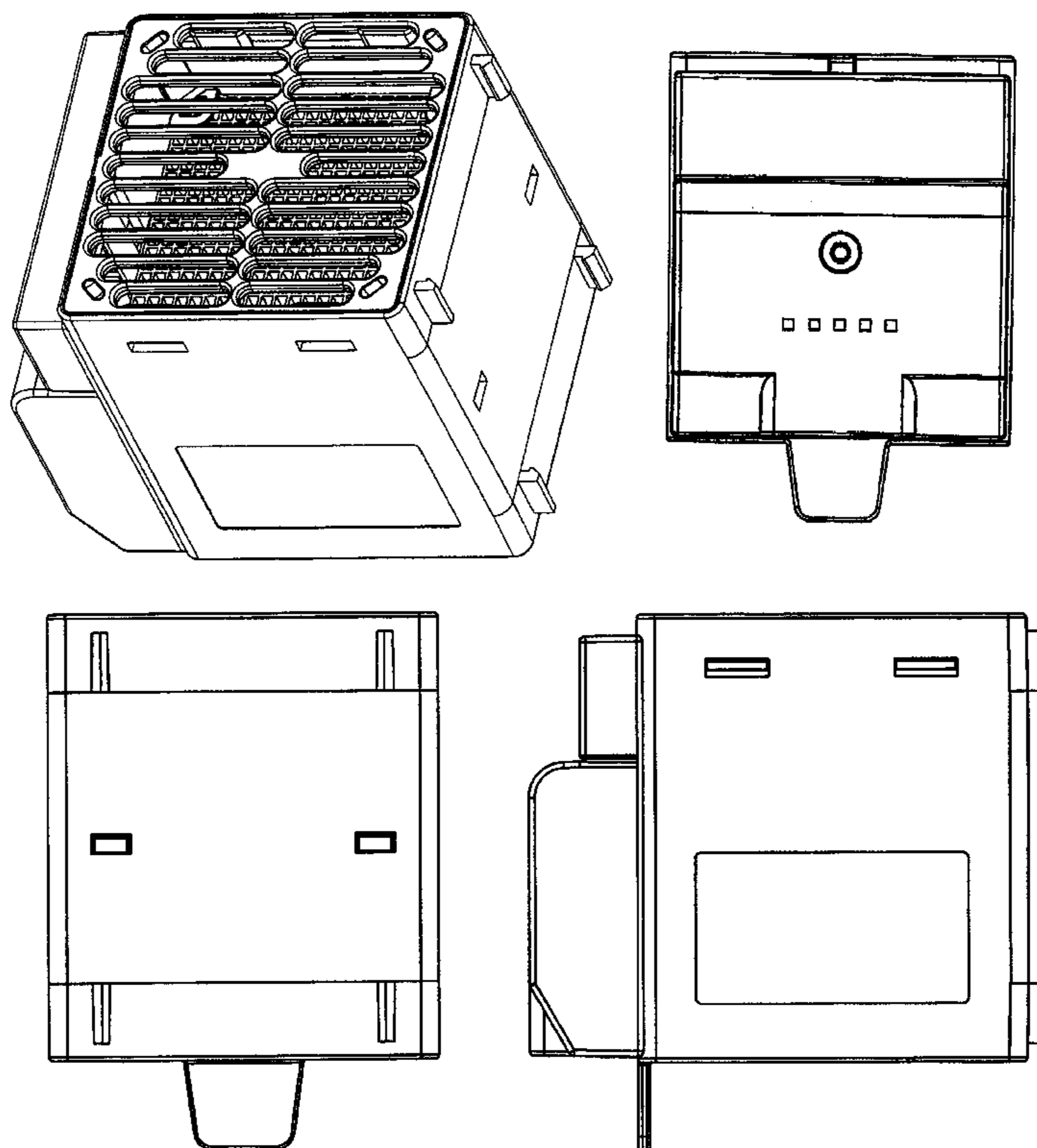

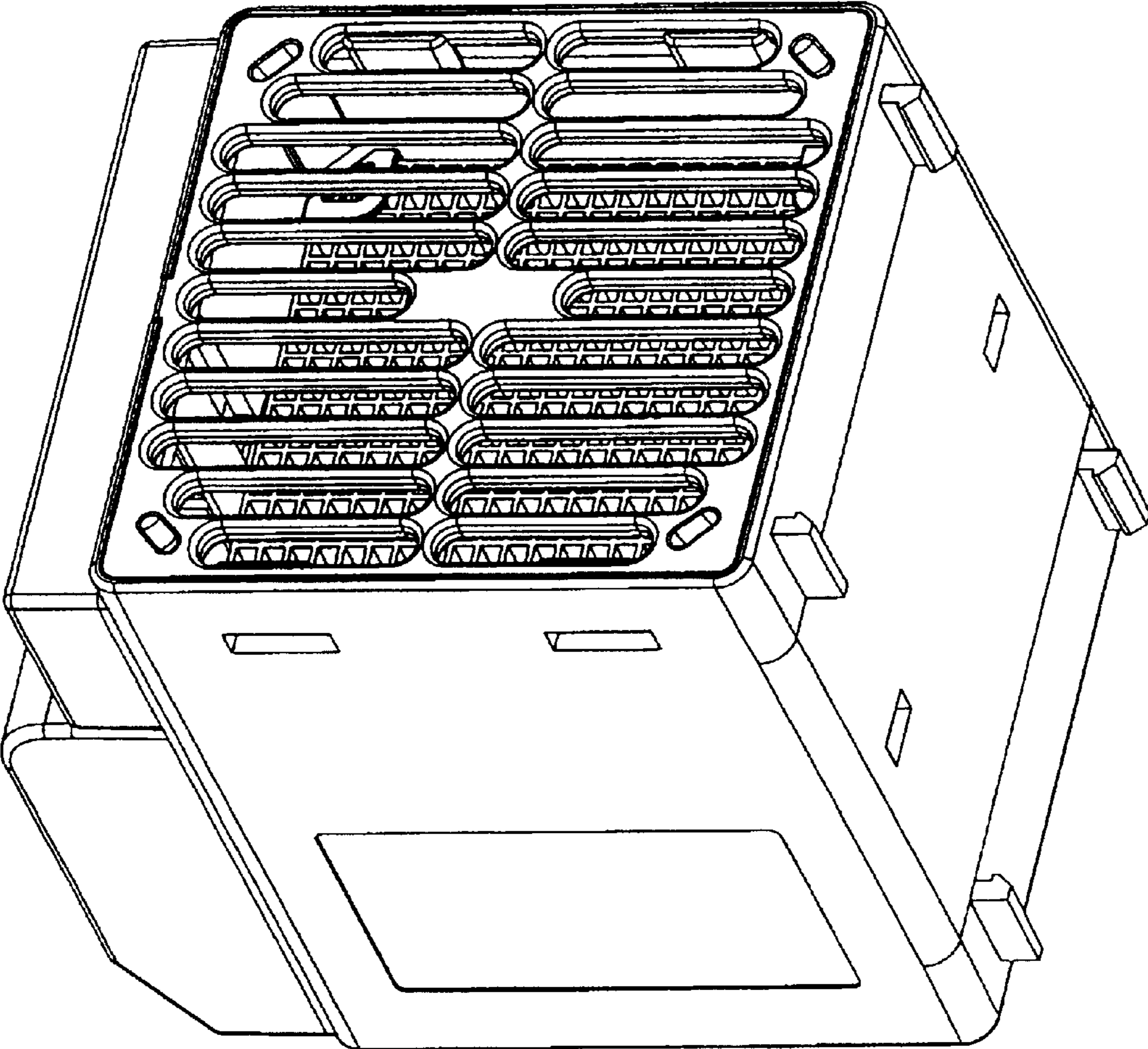

FIG. 1

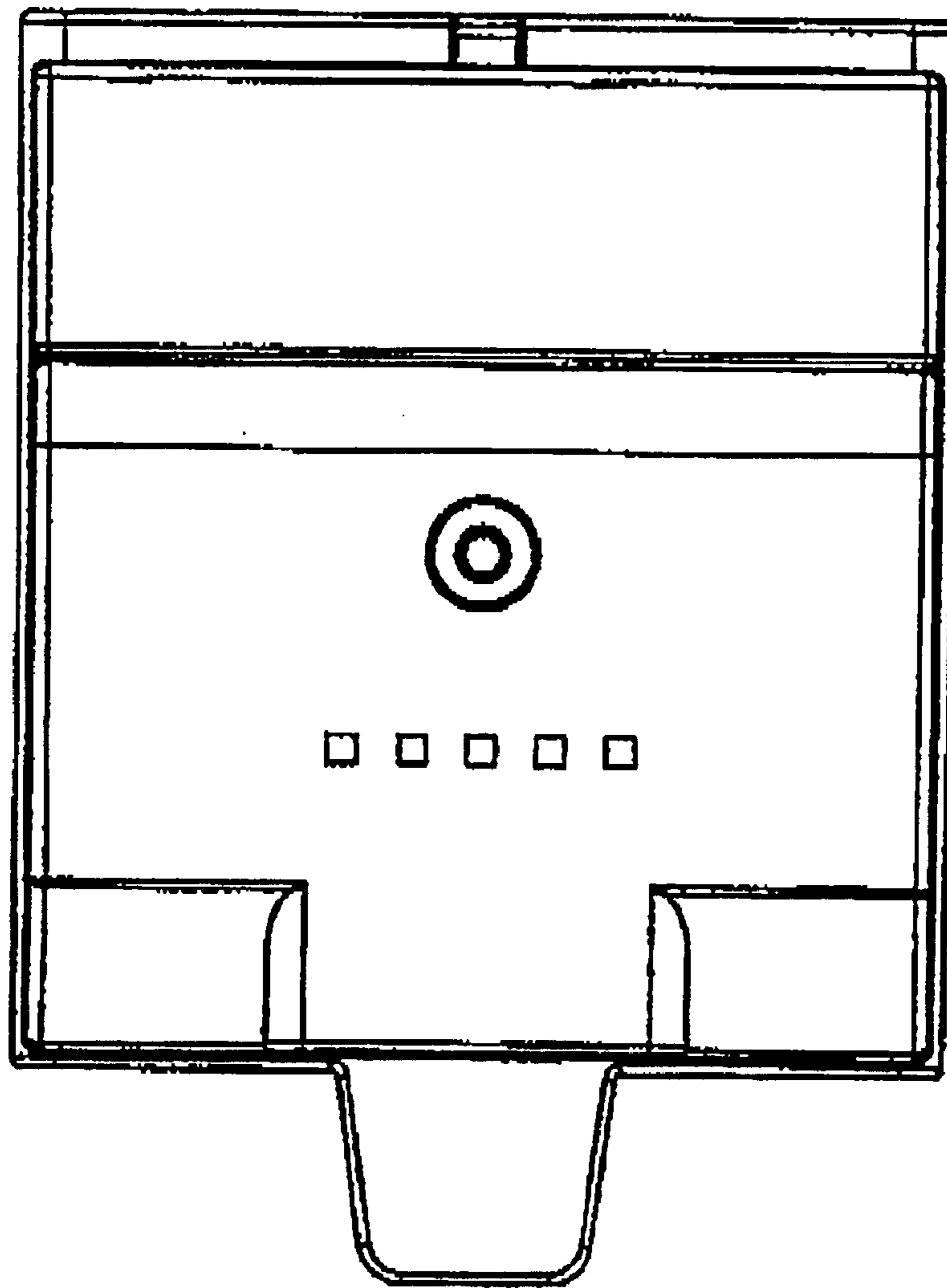

FIG. 2

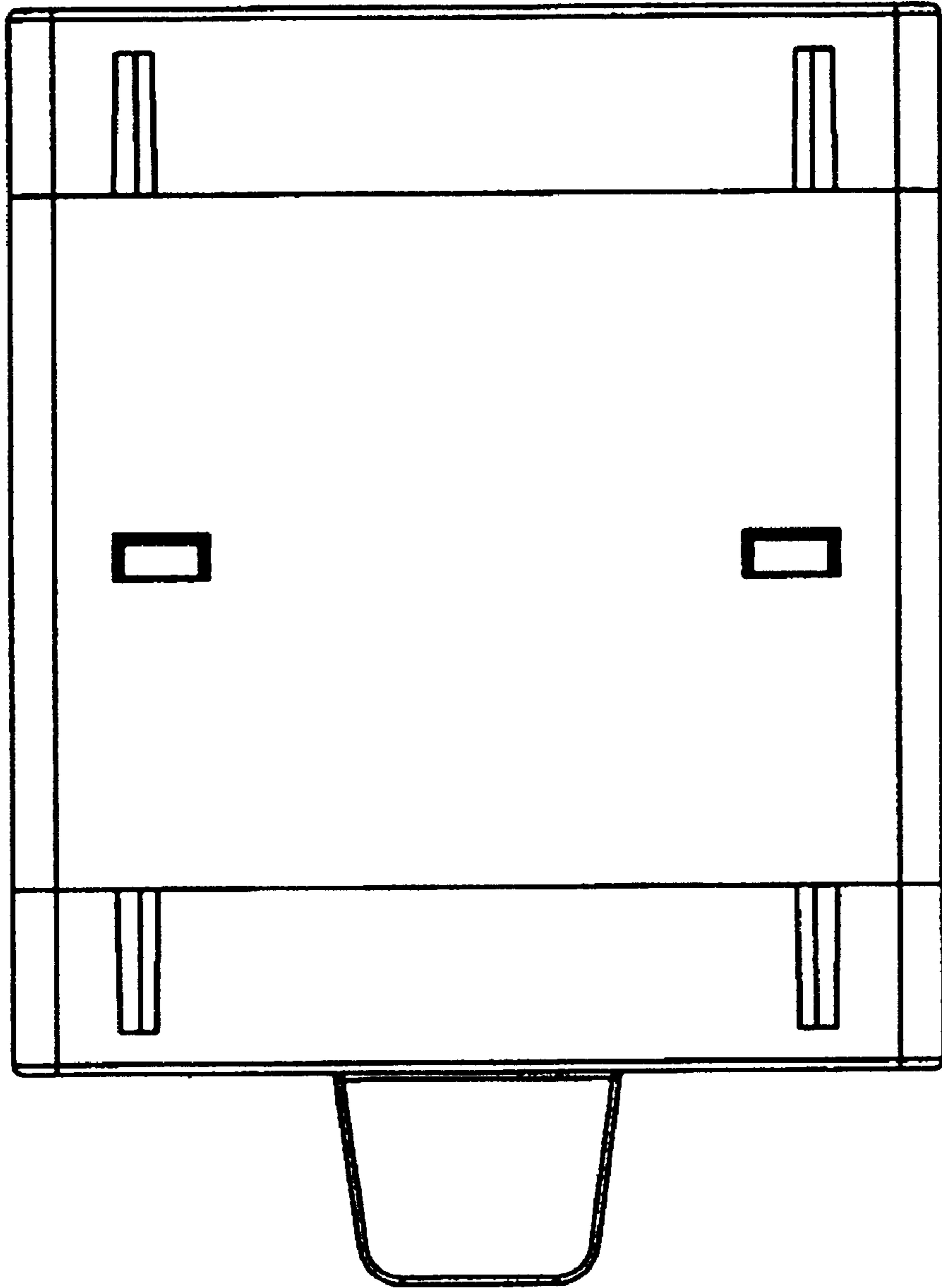

FIG. 3

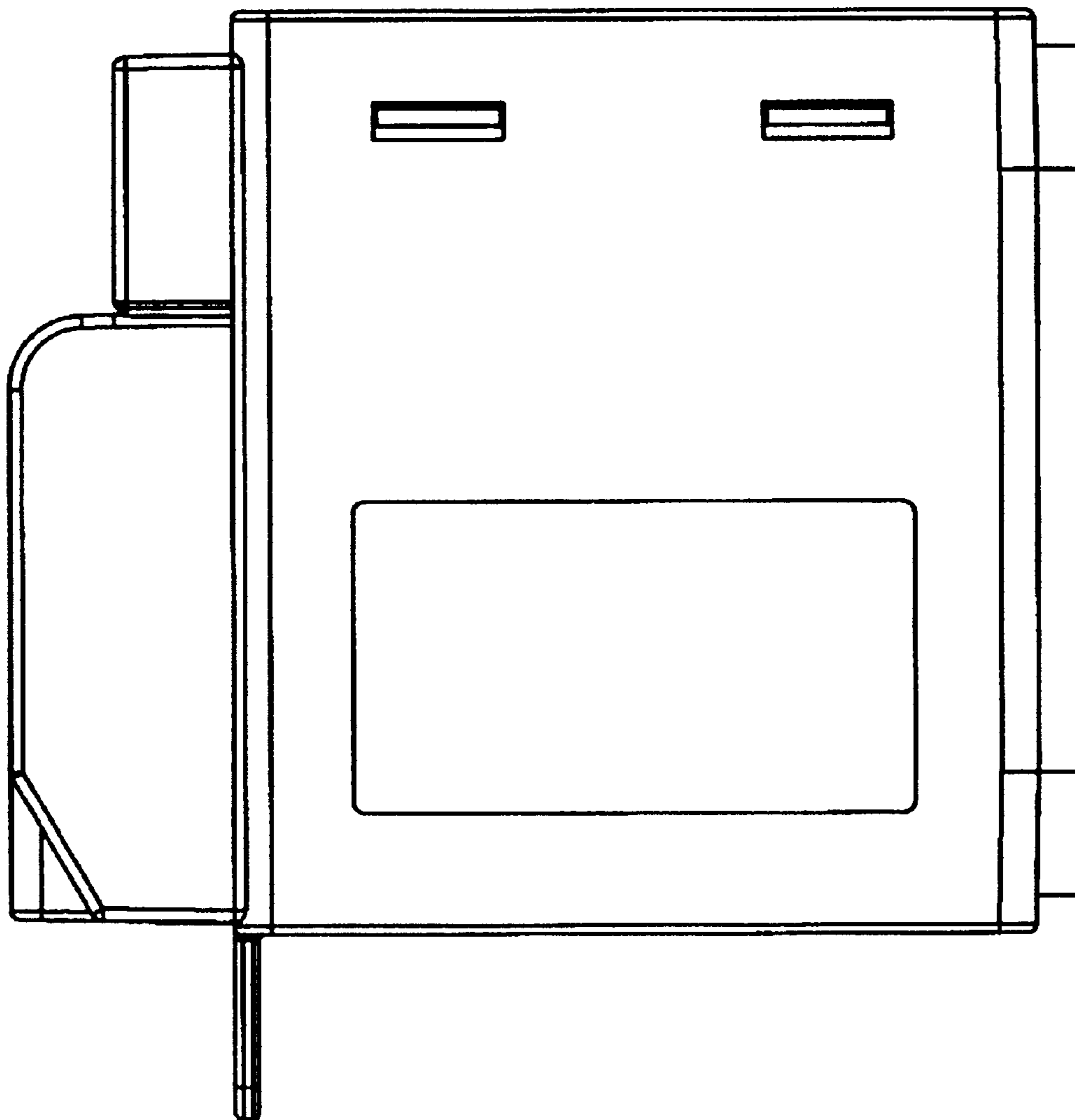

FIG. 4

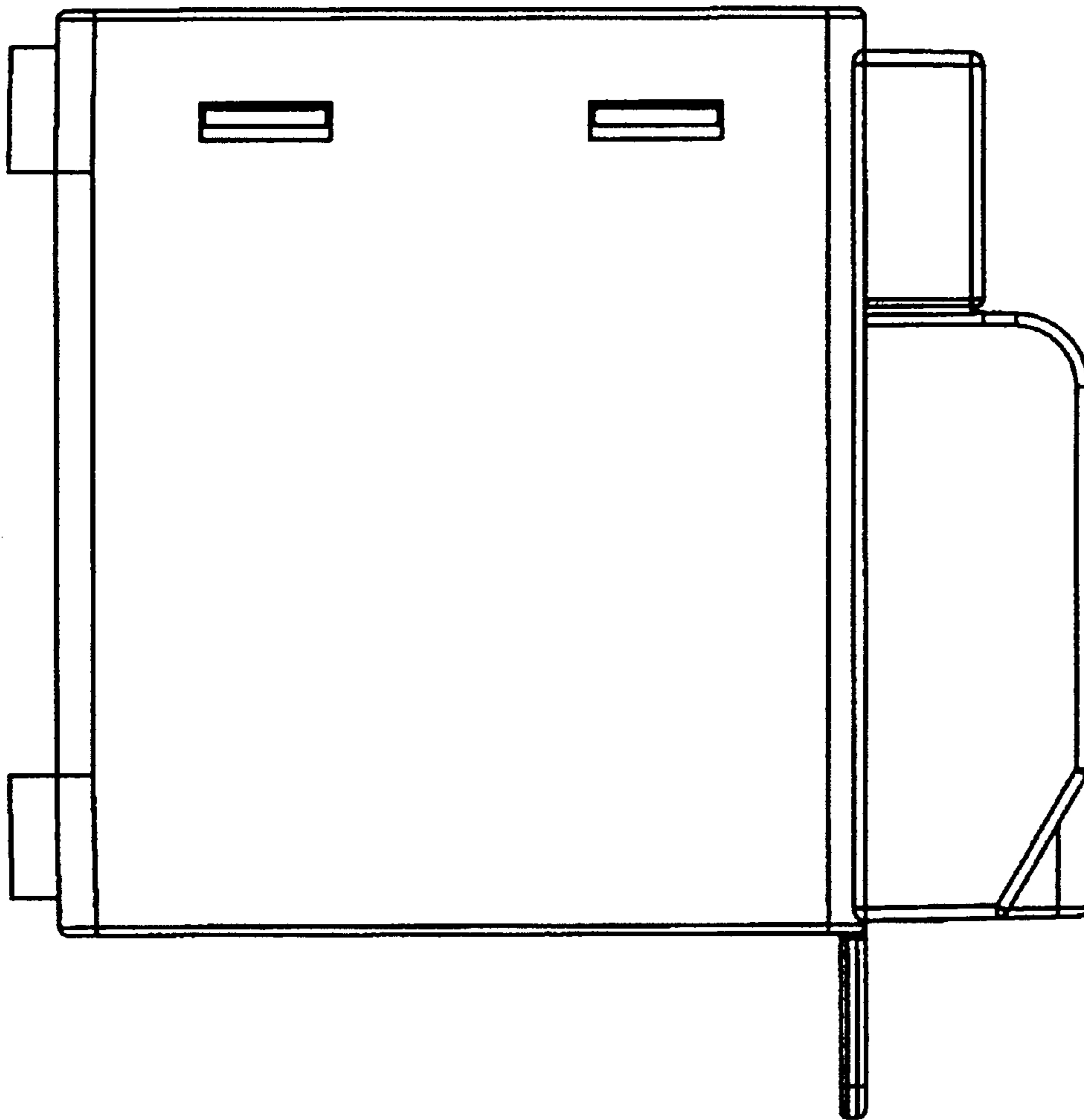

FIG. 5

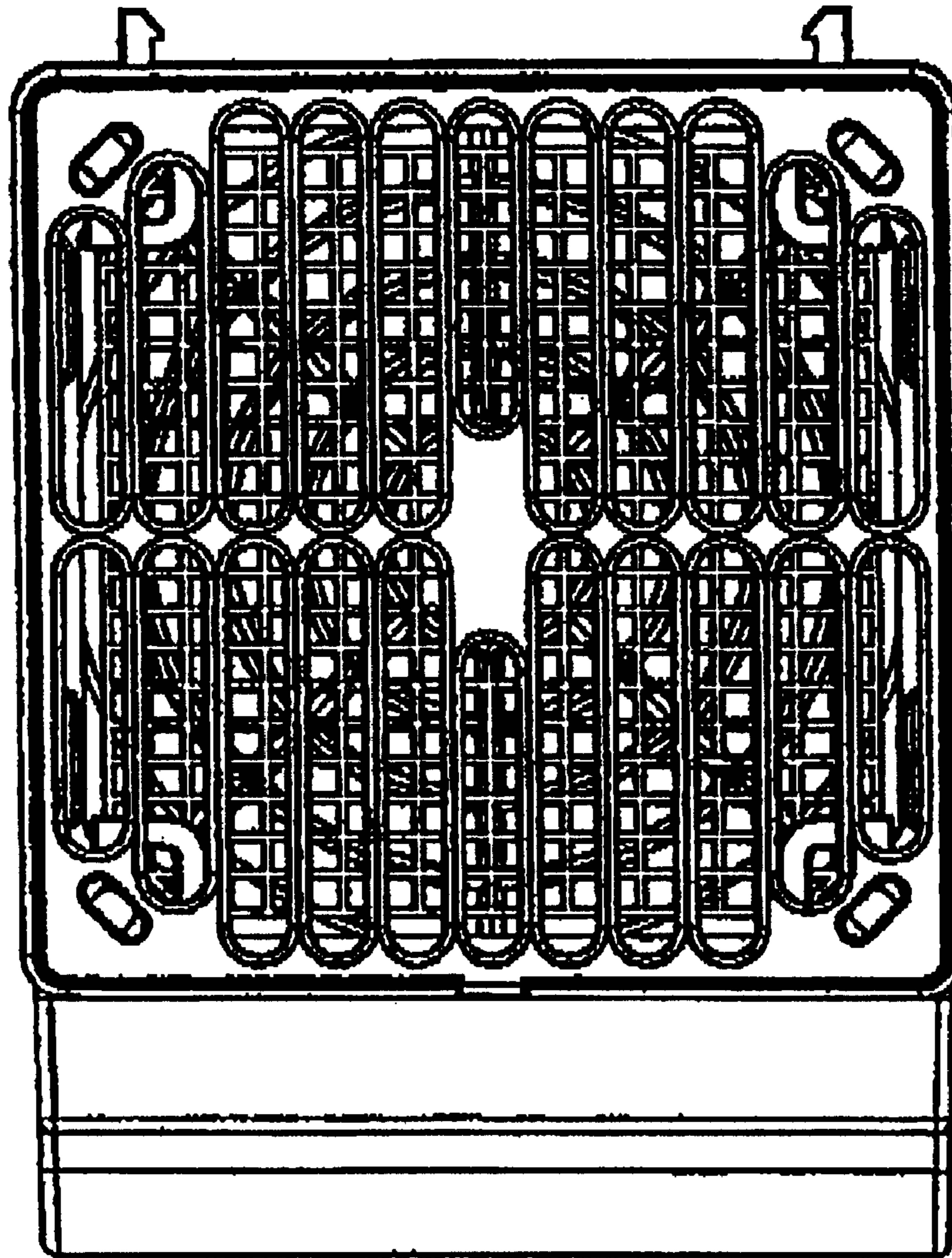

FIG. 6

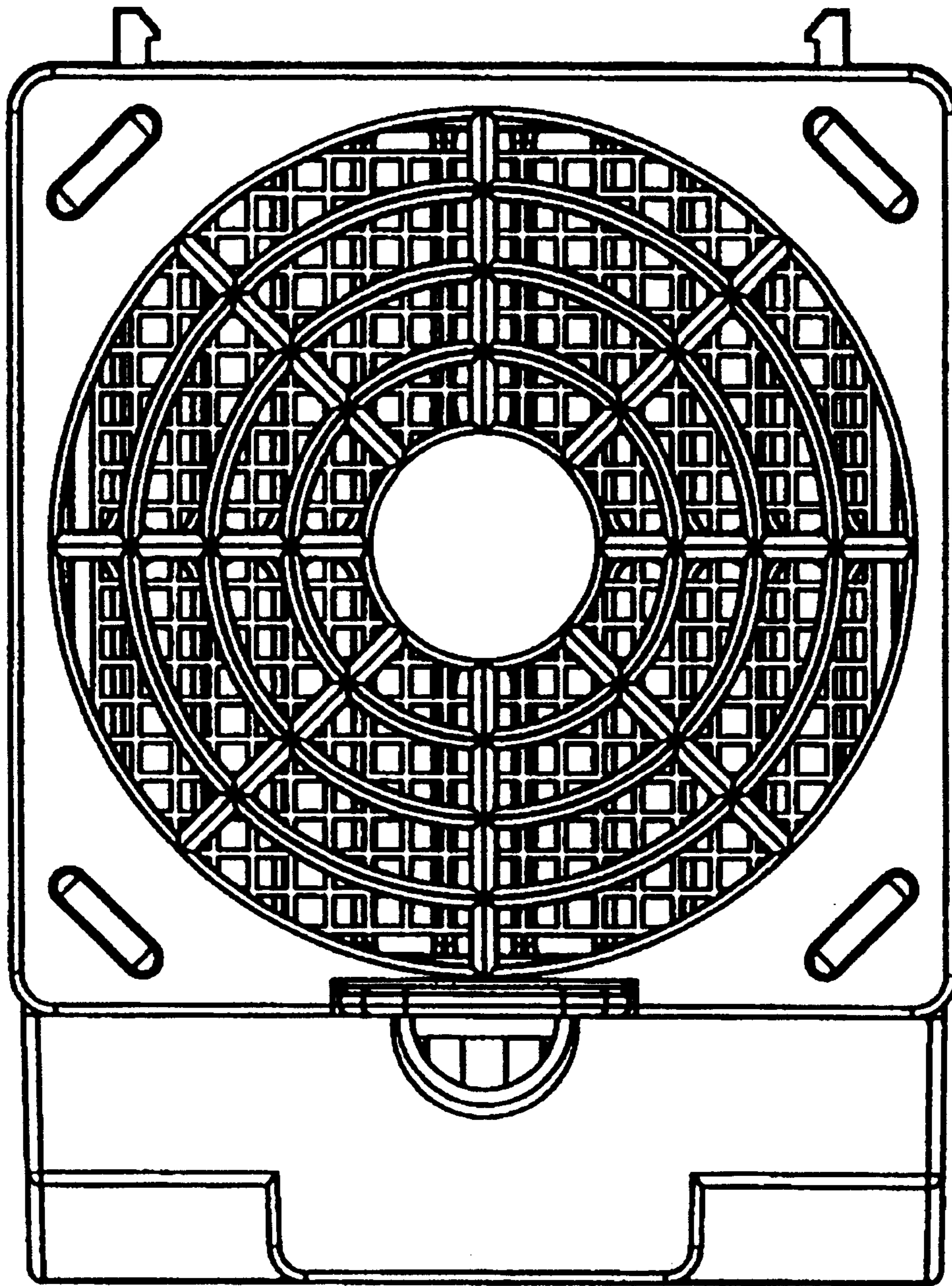

FIG. 7