



US00D536646S

(12) **United States Design Patent**
Shimoguchi et al.

(10) **Patent No.:** **US D536,646 S**

(45) **Date of Patent:** **** Feb. 13, 2007**

(54) **REAR BUMPER FOR A MOTOR VEHICLE**

(75) Inventors: **Kenta Shimoguchi**, Aichi-ken (JP);
Yusuke Fukushima, Tokyo (JP); **Scott Roller**, Newport Beach, CA (US)

(73) Assignee: **Toyota Jidosha Kabushiki Kaisha**,
Aichi-ken (JP)

(**) Term: **14 Years**

(21) Appl. No.: **29/253,271**

(22) Filed: **Feb. 3, 2006**

(51) **LOC (8) Cl.** **12-16**

(52) **U.S. Cl.** **D12/169**

(58) **Field of Classification Search** D12/90-92,
D12/86, 169, 196, 163; 296/180.1, 180.2;
293/102, 113, 115, 117, 120

See application file for complete search history.

(56) **References Cited**

U.S. PATENT DOCUMENTS

| | | | |
|------------|----------|----------------|---------|
| D477,258 S | 7/2003 | Hayashi | |
| D491,496 S | 6/2004 | Metros et al. | |
| D497,851 S | 11/2004 | Metros et al. | |
| D501,809 S | 2/2005 | Metros et al. | |
| D512,351 S | 12/2005 | Hattori | |
| D516,476 S | * 3/2006 | Iwanaga et al. | D12/169 |
| D516,969 S | * 3/2006 | Honda et al. | D12/169 |
| D522,418 S | * 6/2006 | Truebsbach | D12/169 |

OTHER PUBLICATIONS

Brochure of Titan, 2004, Nissan Motor Co., Ltd., Nissan Titan.

Brochure of Raider, 2005, Mitsubishi Motor Coporation, Mitsubishi Raider.

Brochure of Ridgeline, 2005, Honda Motor Co., Ltd., Honda Ridgeline.

Public relations material, 2003, Ford Motor Company, FORD F-150.

* cited by examiner

Primary Examiner—Melody N. Brown

(74) *Attorney, Agent, or Firm*—Finnegan, Henderson, Farabow, Garrett & Dunner, L.L.P.

(57) **CLAIM**

The ornamental design for a rear bumper for a motor vehicle, as shown and described.

DESCRIPTION

FIG. 1 is a perspective view of a rear bumper for a motor vehicle of our new design;

FIG. 2 is a front view thereof;

FIG. 3 is a rear view thereof;

FIG. 4 is a top plan view thereof;

FIG. 5 is a bottom view thereof;

FIG. 6 is a right-side view thereof;

FIG. 7 is a left-side view thereof;

FIG. 8 is a cross-sectional view of our new design taken along the line 8—8 in FIG. 2, showing the profile of that portion of the design;

FIG. 9 is a cross-sectional view of our new design taken along the line 9—9 in FIG. 2, showing the profile of that portion of the design; and,

FIG. 10 is a cross-sectional view of our new design taken along the line 10—10 in FIG. 2, showing the profile of that portion of the design.

As used herein, right and left refer to the orientation of the design depicted in the figures above, not the right and left sides of the design when mounted on a motor vehicle.

1 Claim, 5 Drawing Sheets

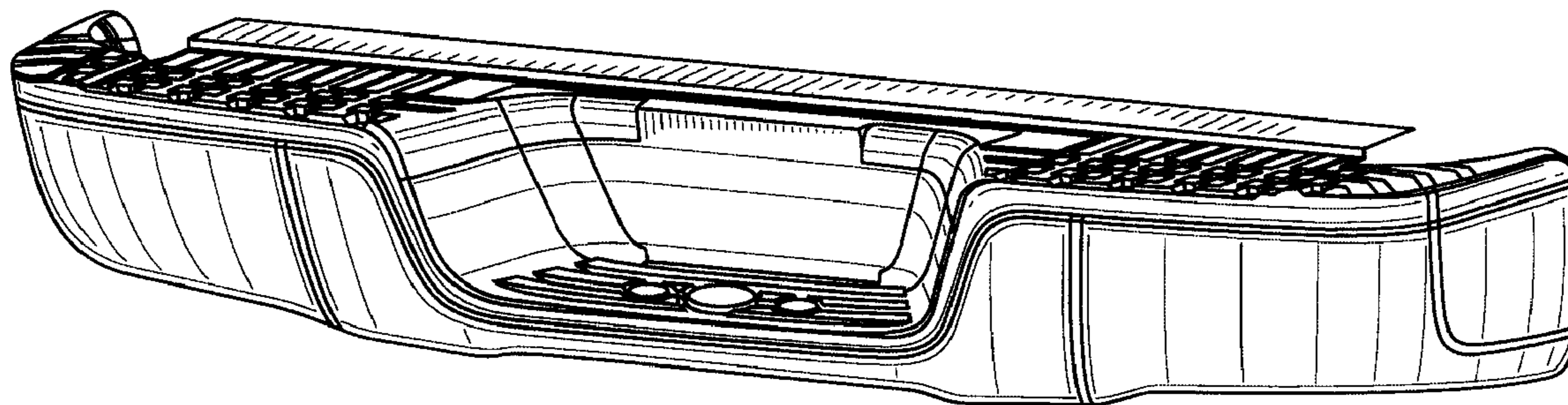

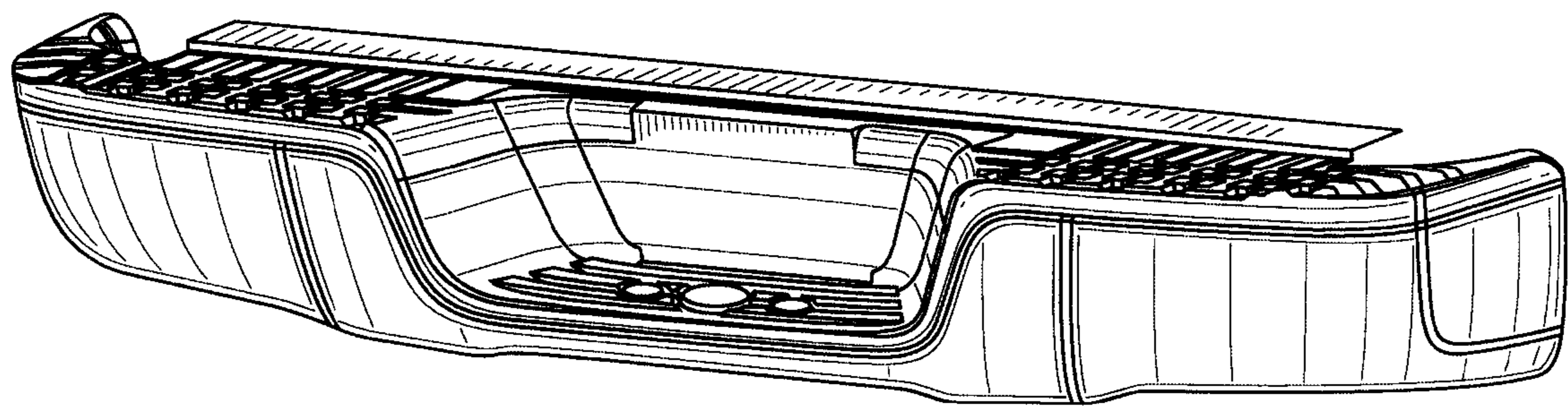

FIG. 1

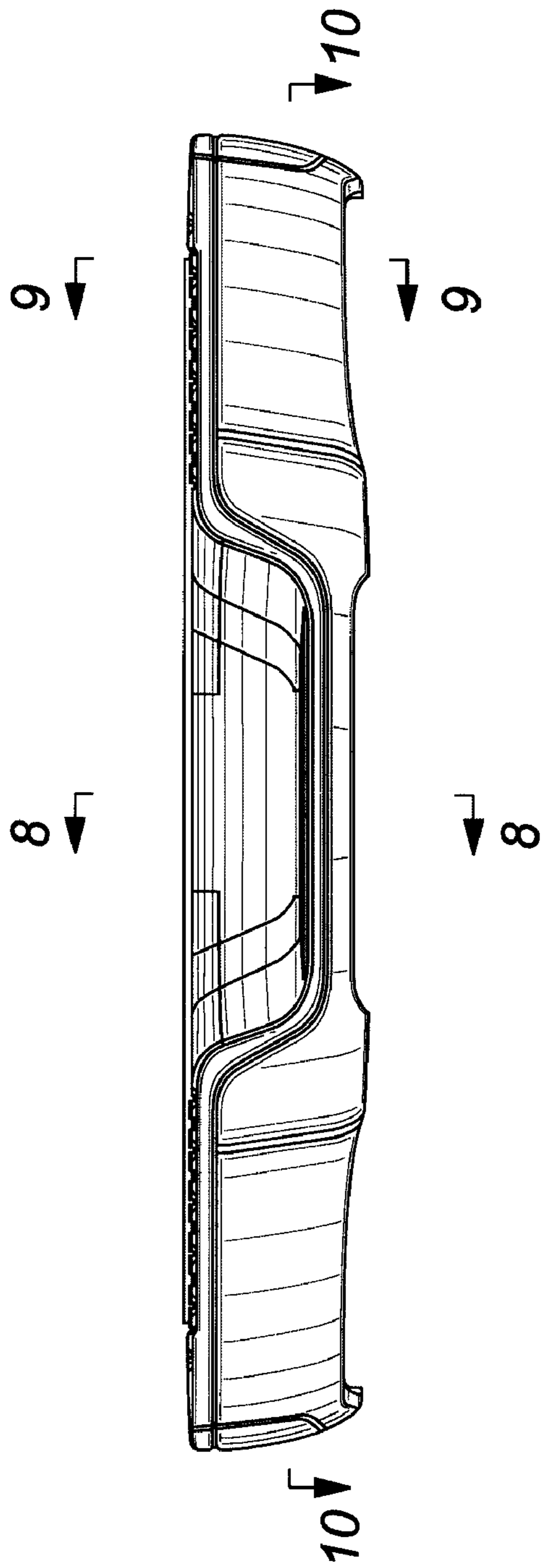

FIG. 2

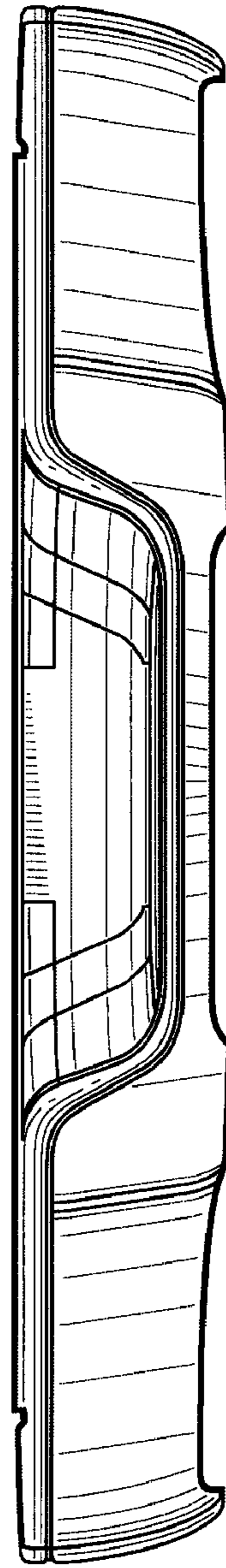

FIG. 3

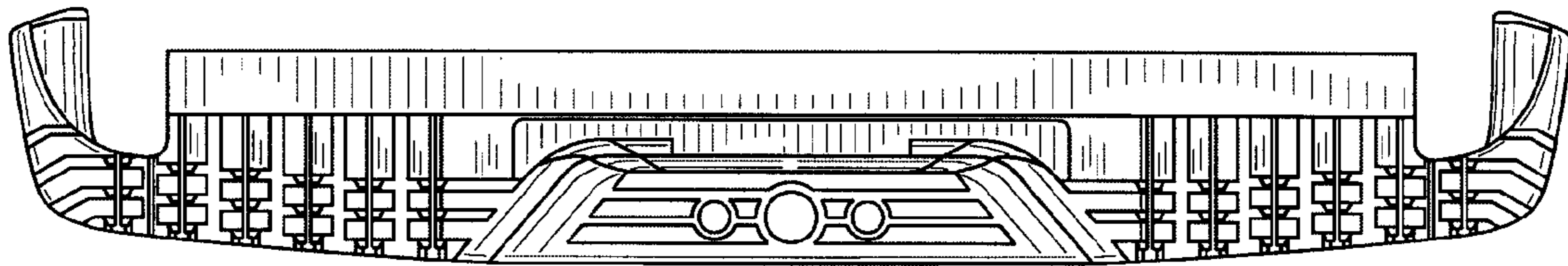

FIG. 4

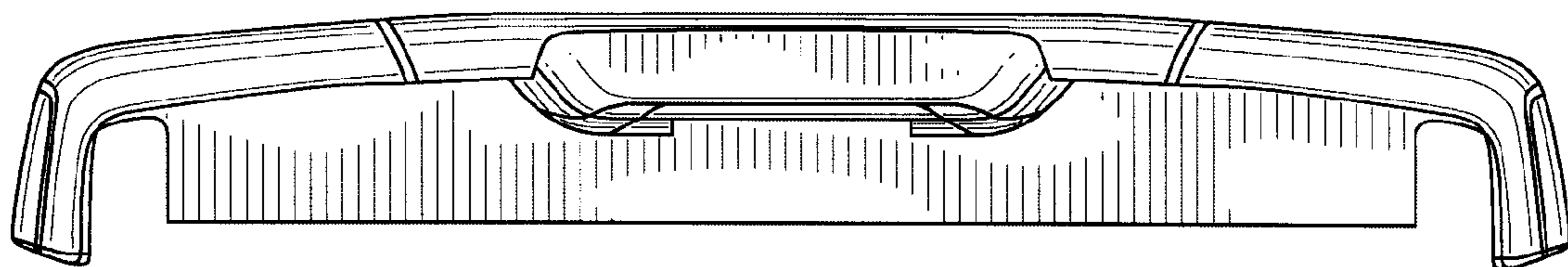

FIG. 5

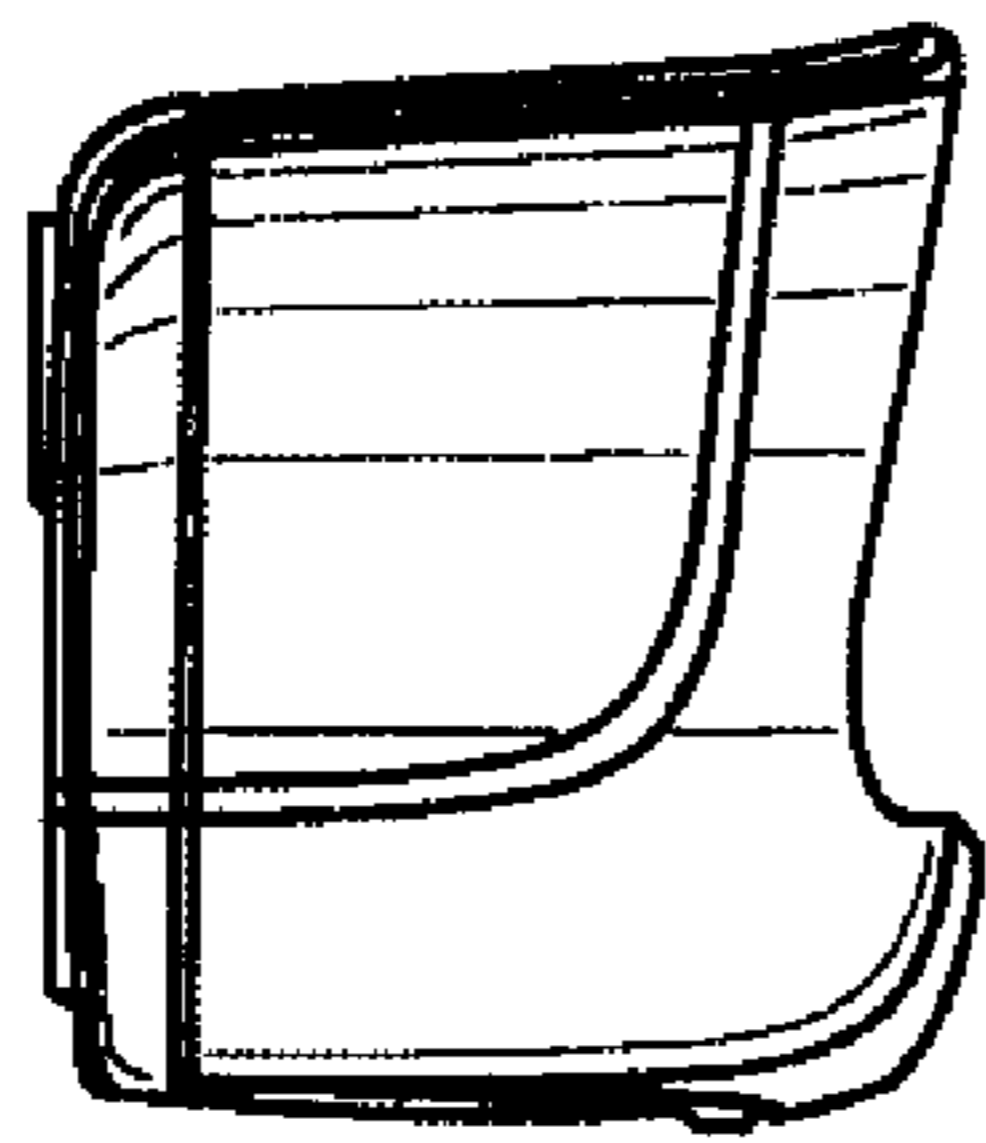

FIG. 6

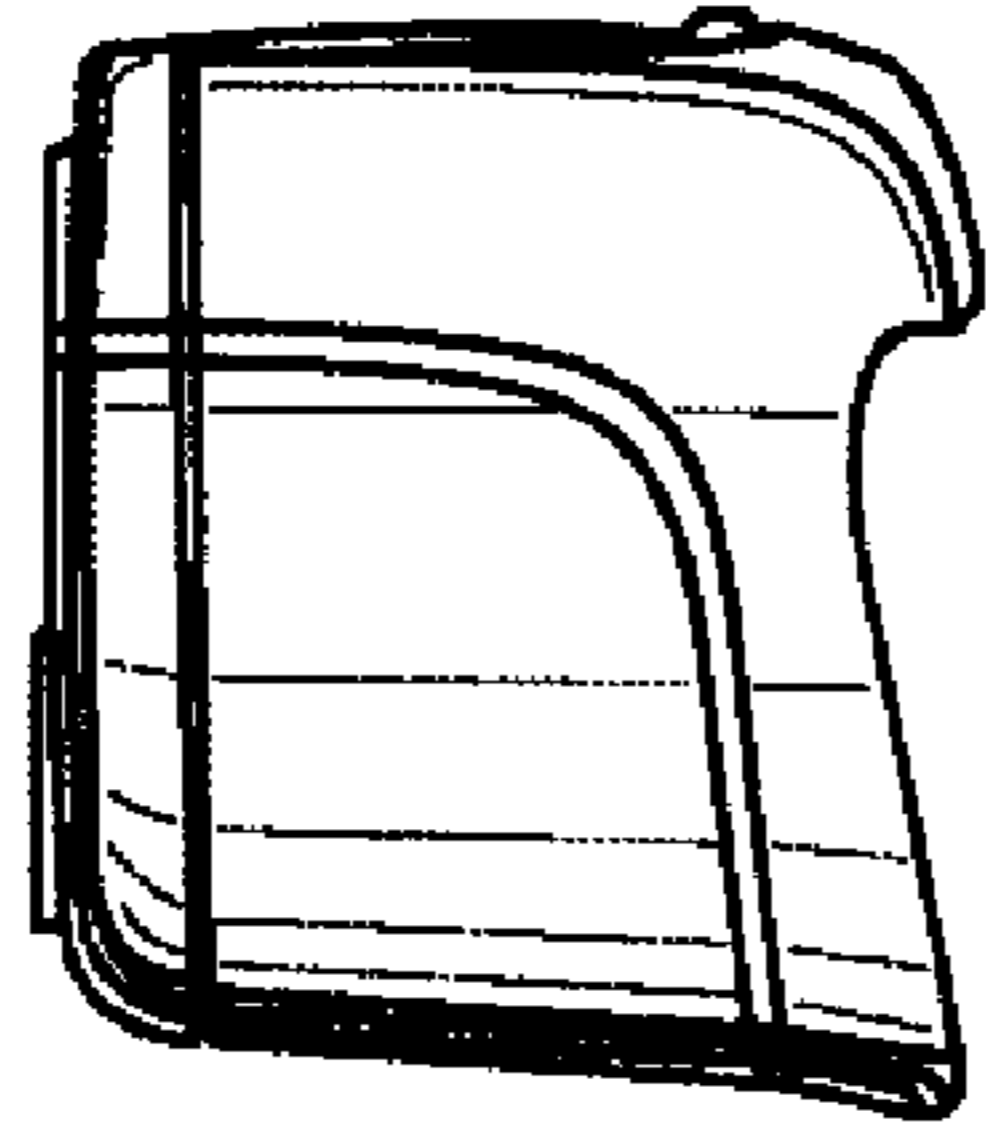

FIG. 7

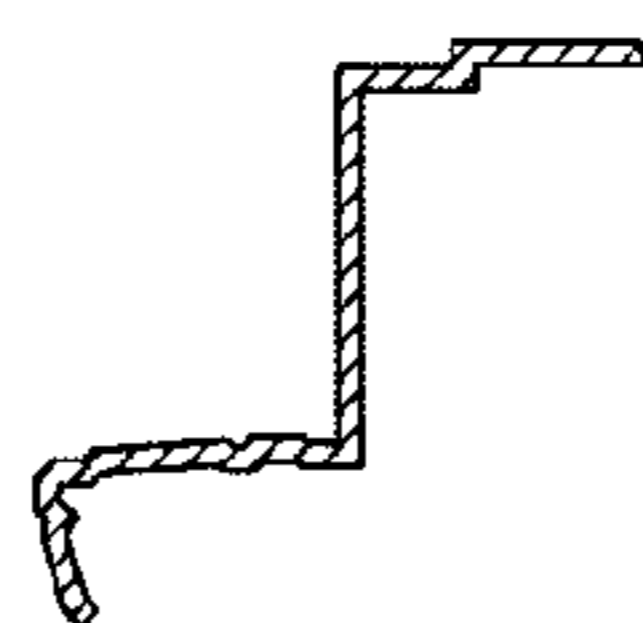

FIG. 8

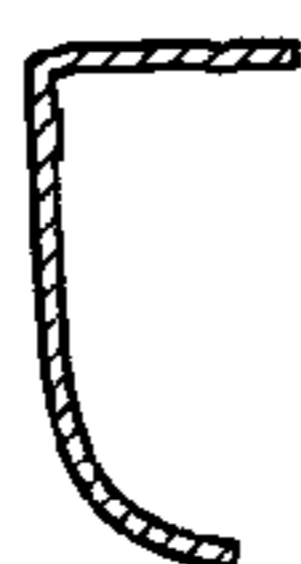

FIG. 9

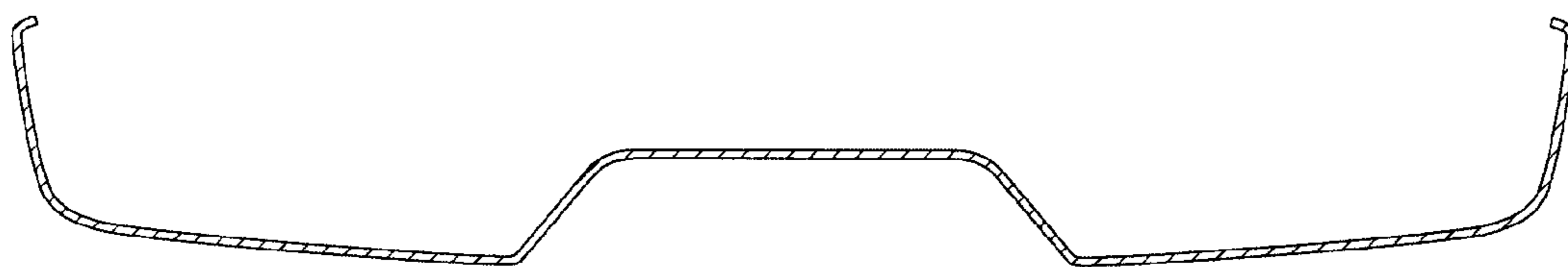

FIG. 10