



US00D536380S

(12) **United States Design Patent**
Clifton

(10) **Patent No.:** **US D536,380 S**

(45) **Date of Patent:** **** Feb. 6, 2007**

(54) **TILABLE REAR PROJECTION DISPLAY MODULE**

(75) **Inventor:** **Benjamin R. Clifton**, Oregon City, OR (US)

(73) **Assignee:** **Clarity Visual Systems, Inc.**, Wilsonville, OR (US)

(**) **Term:** **14 Years**

(21) **Appl. No.:** **29/221,493**

(22) **Filed:** **Jan. 12, 2005**

(51) **LOC (8) Cl.** **20-01**

(52) **U.S. Cl.** **D20/10**

(58) **Field of Classification Search** D20/10, D20/18, 19, 21, 39, 41, 42, 43, 99; D14/128, D14/374, 375; 40/427, 442, 564, 570; 345/87; 348/184, 739, 787

See application file for complete search history.

(56) **References Cited**

U.S. PATENT DOCUMENTS

D339,574 S * 9/1993 Althans et al. D14/374

(Continued)

Primary Examiner—Robert M. Spear

(74) *Attorney, Agent, or Firm*—Stoel Rives LLP

(57) **CLAIM**

I claim the ornamental design for a tilable rear projection display module, as shown and described.

DESCRIPTION

FIG. 1 is a right side frontal isometric view of a tilable rear projection display module;

FIGS. 2 and 3 are respective left side and right side rear isometric views thereof;

FIGS. 4 and 5 are respective front and rear elevation views thereof;

FIGS. 6 and 7 are respective left side and right side elevation views thereof;

FIGS. 8 and 9 are respective top and bottom plan views thereof; and

FIG. 10 is a left side frontal isometric view of the display module of FIG. 1, shown with a removable screen brace installed as a facade of a bottom tilable rear projection display module.

FIG. 11 is a right side frontal isometric view of the display module in the environment of a vertical stack of a selectable number of display modules of the type shown in FIGS. 1–10. One of the display modules is shown in solid lines and positioned between two other of the display modules shown in broken lines to illustrate the matable relationship of the confronting surfaces of adjacent vertically stacked display modules.

FIG. 12 is a left side elevation view of the vertical stack of the display modules of FIG. 11.

FIG. 13 is a right side frontal isometric view of the display module of FIG. 1, shown in an alternate environment having an additional display module of FIG. 1 shown in broken lines and positioned adjacent the left side of the display module shown in solid lines to illustrate the matable relationship of the confronting surfaces of a selectable number of adjacent horizontally positioned display modules.

FIG. 14 is a left side rear isometric view of the display module of FIG. 1, shown in an alternate environment having the form of a horizontal row of a selectable number of display modules of the type shown in FIGS. 1–9. One of the display modules is shown in solid lines and positioned between two other of the display modules shown in broken lines to illustrate the matable relationship of the confronting surfaces of adjacent display modules; and,

FIG. 15 is a left side rear isometric view of left side rear isometric view of the display module of FIG. 1, shown in an alternate environment having the form of a two-dimensional array of a selectable number of display modules of the type shown in FIGS. 1–9. One of the display modules is shown in solid lines and positioned in a vertical column below one of the display modules shown in broken lines and positioned in a horizontal row adjacent another one of the display modules shown in broken lines to illustrate the expandability of the tilable rear projection display module wall to form a two-dimensional array.

Items shown in broken lines in FIGS. 1–15 are for illustrative purposes only and form no part of the claimed design.

1 Claim, 10 Drawing Sheets

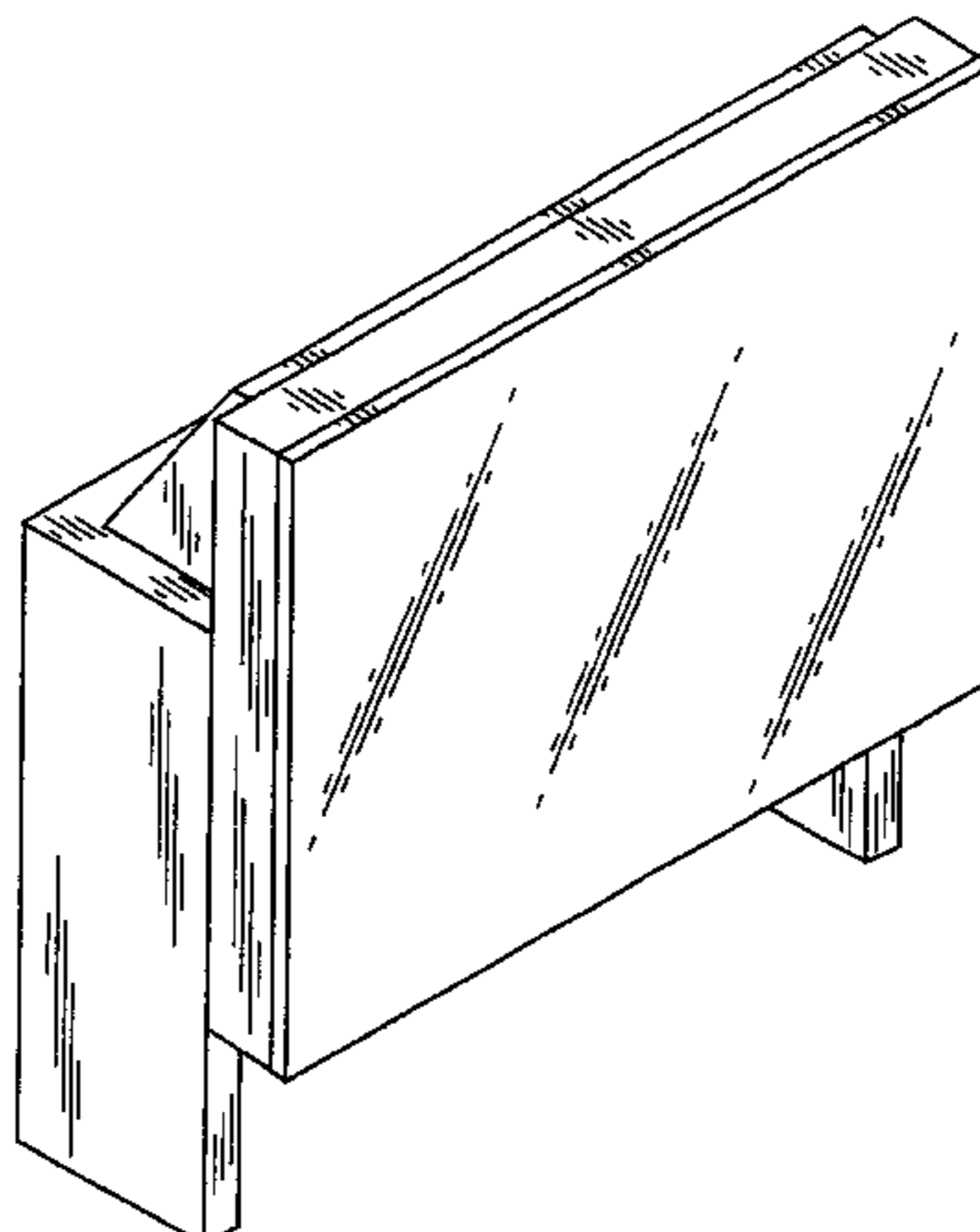

US D536,380 S

Page 2

U.S. PATENT DOCUMENTS

D342,505 S	*	12/1993	Shimatani et al.	D14/128	D483,727 S	*	12/2003	Tseng et al.	D14/128
D345,968 S	*	4/1994	Bruce et al.	D14/371	6,728,032 B1	*	4/2004	Peterson et al.	359/460
D394,089 S	*	5/1998	Kawasaki et al.	D20/10	D493,431 S	*	7/2004	Forlenza et al.	D14/128
D431,232 S	*	9/2000	Yokoyama et al.	D14/128	D494,942 S	*	8/2004	Forlenza	D14/128
D438,256 S	*	2/2001	Timmermans et al.	D20/10	D496,010 S	*	9/2004	Honda	D14/128
D452,884 S	*	1/2002	Metral	D20/10	D505,404 S	*	5/2005	Forlenza et al.	D14/128
D455,129 S	*	4/2002	Niitsu	D14/126	2004/0027499 A1	*	2/2004	Lowe	348/787

* cited by examiner

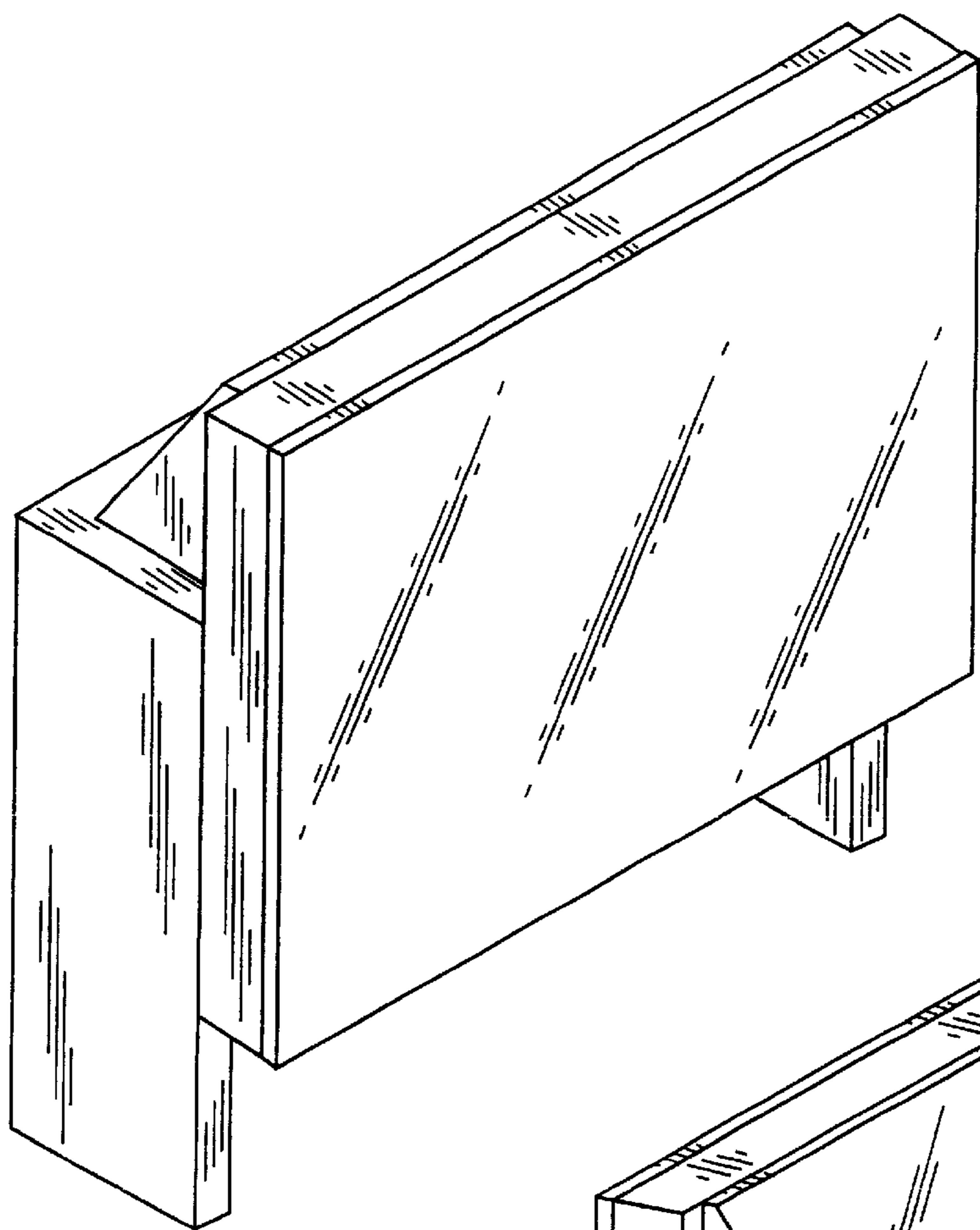

FIG. 1

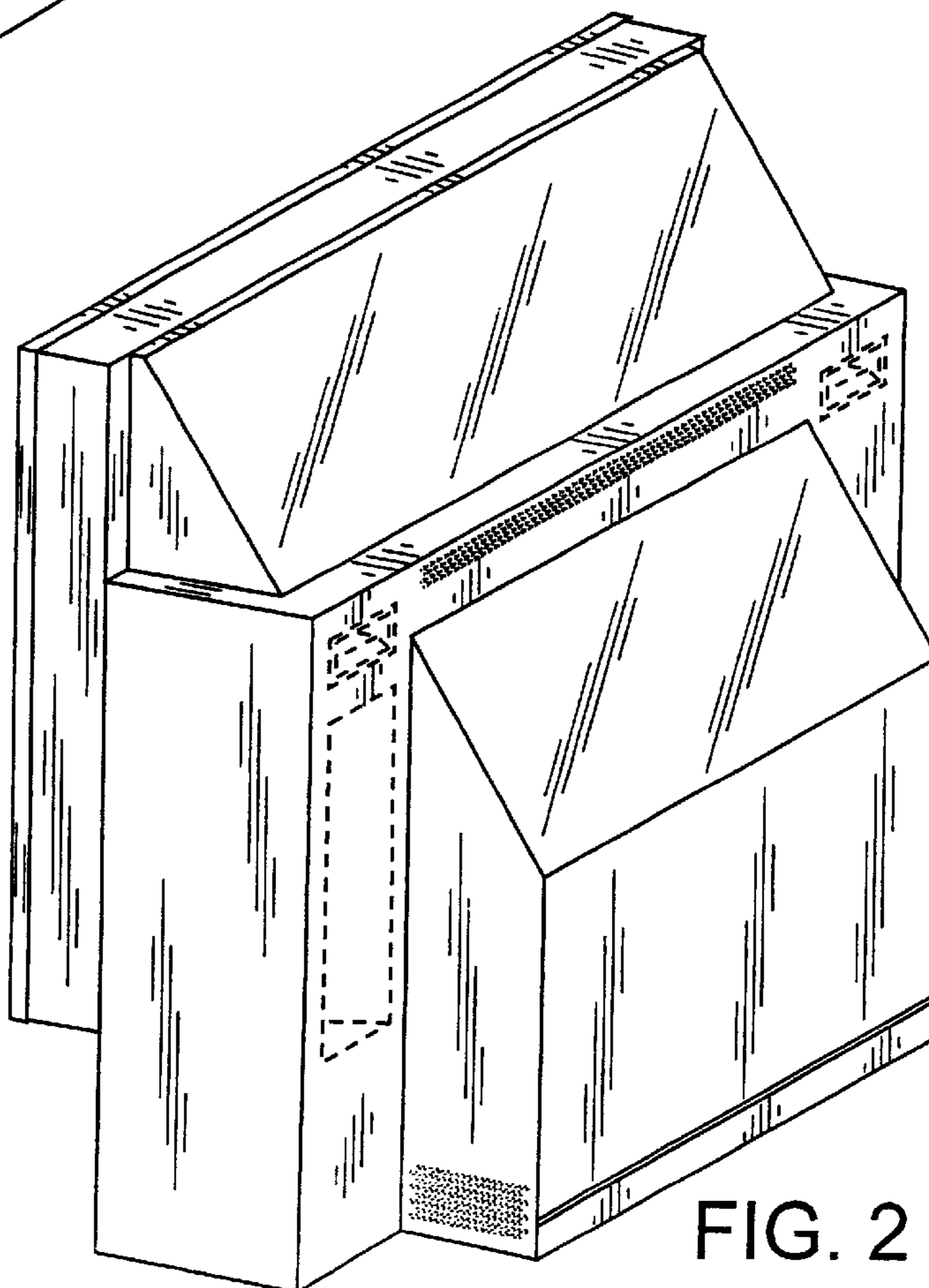

FIG. 2

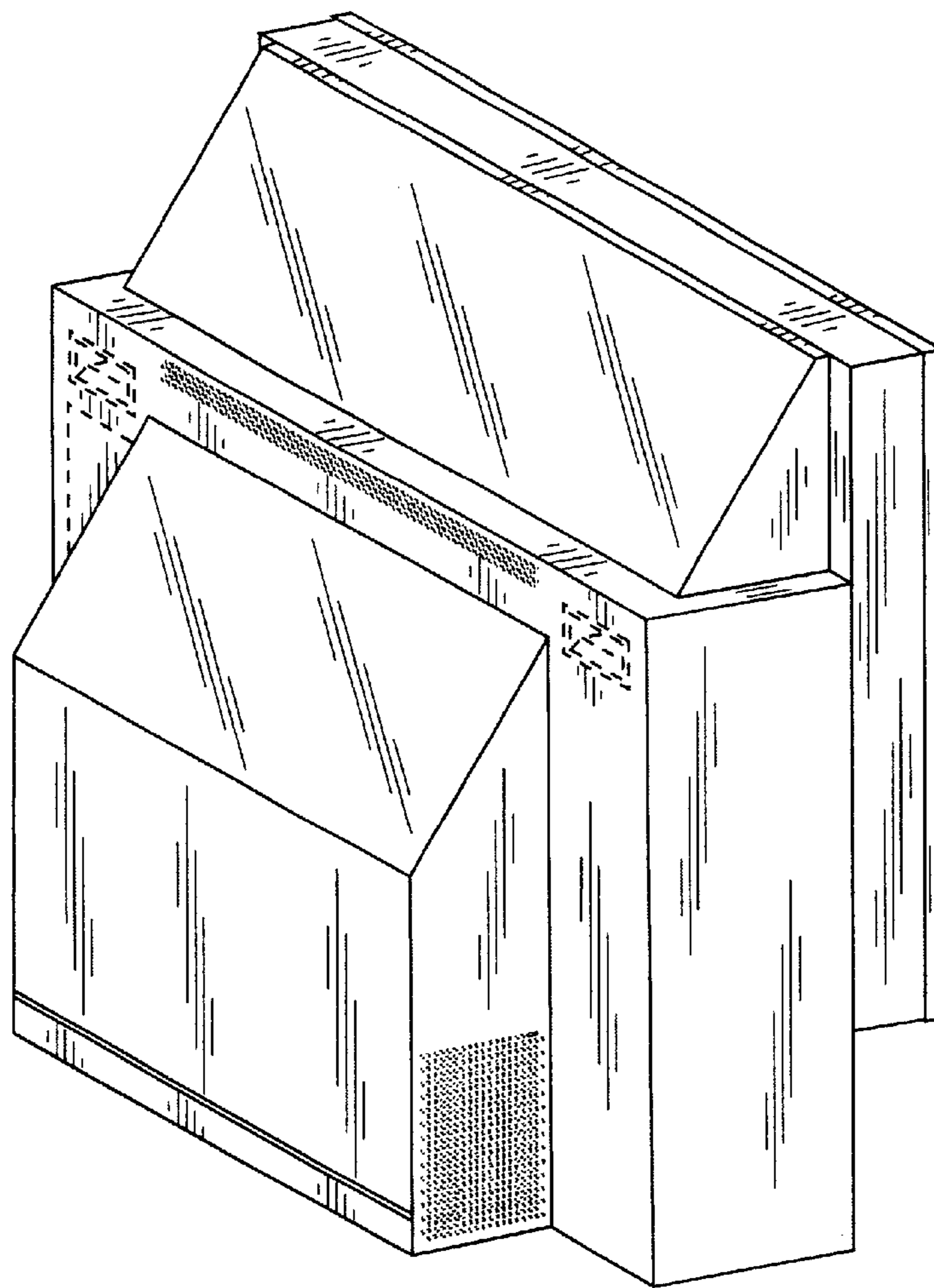

FIG. 3

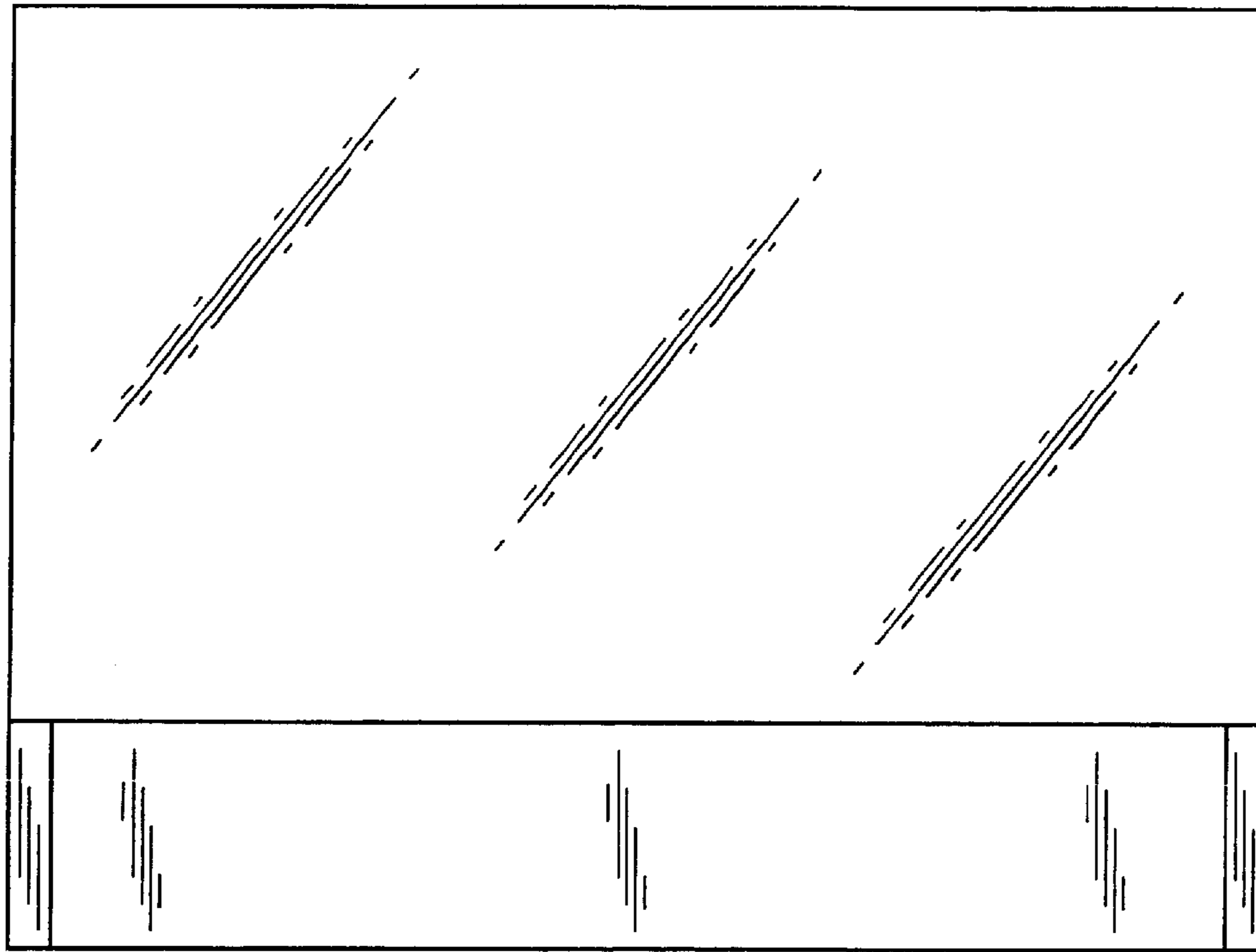

FIG. 4

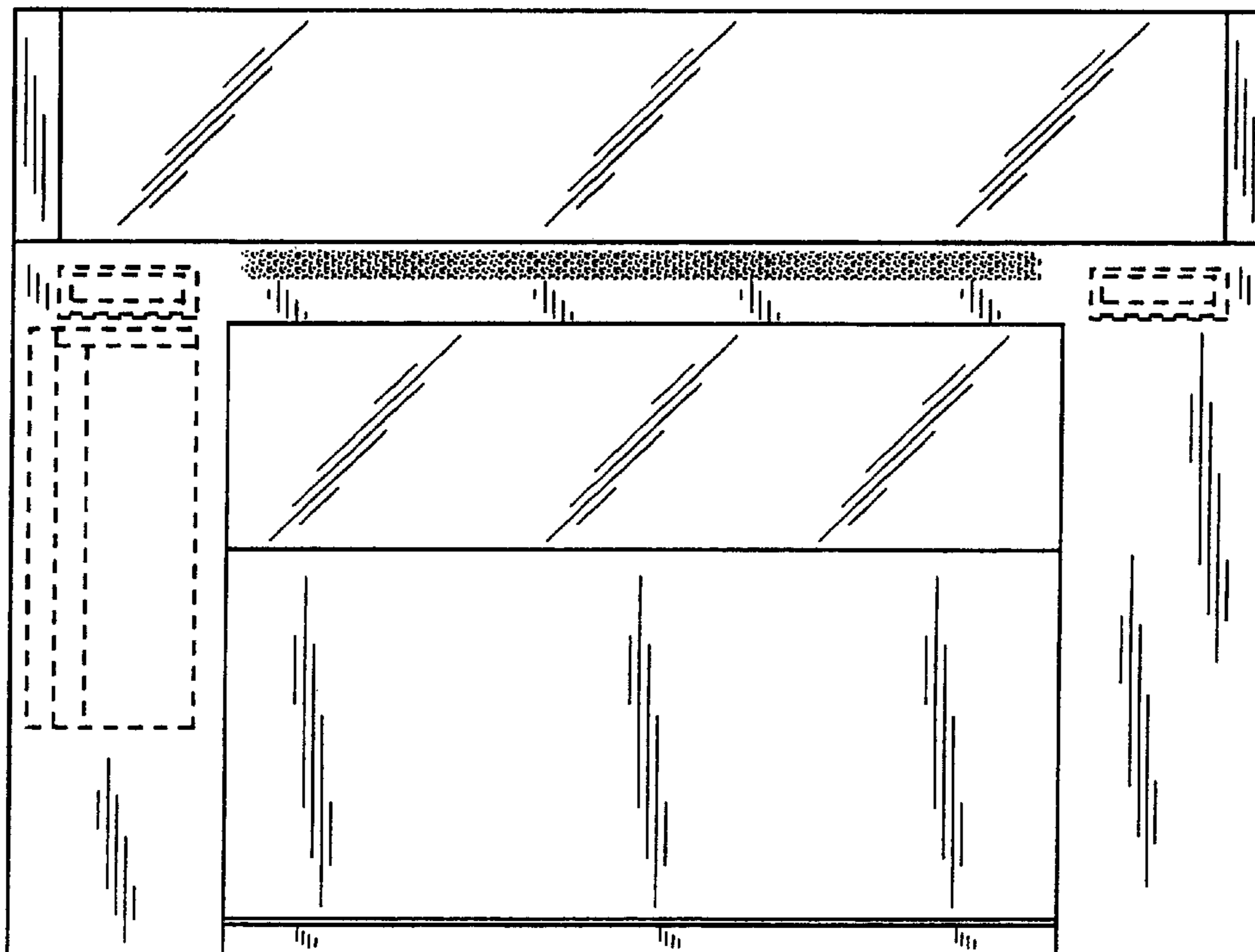

FIG. 5

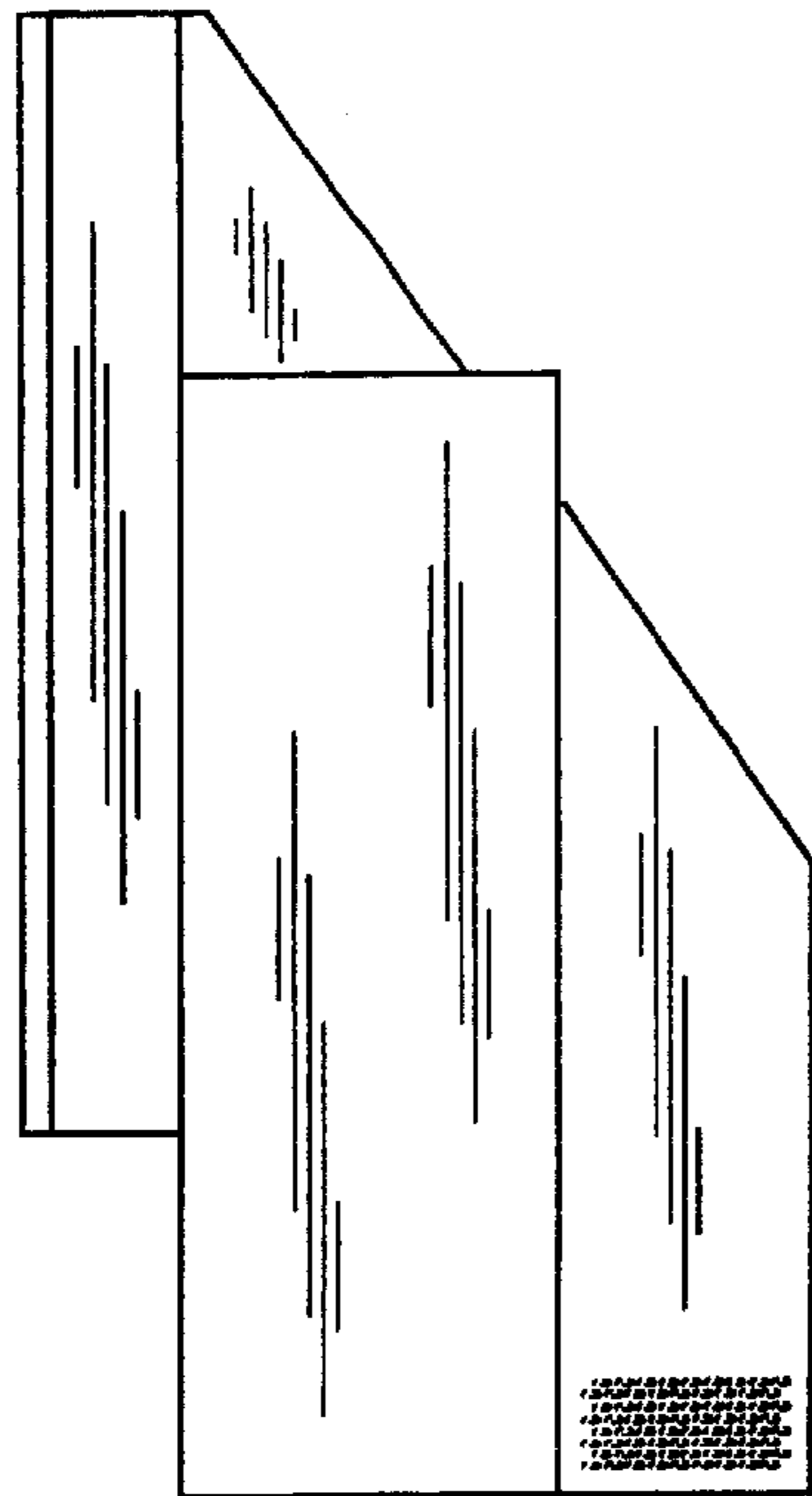

FIG. 6

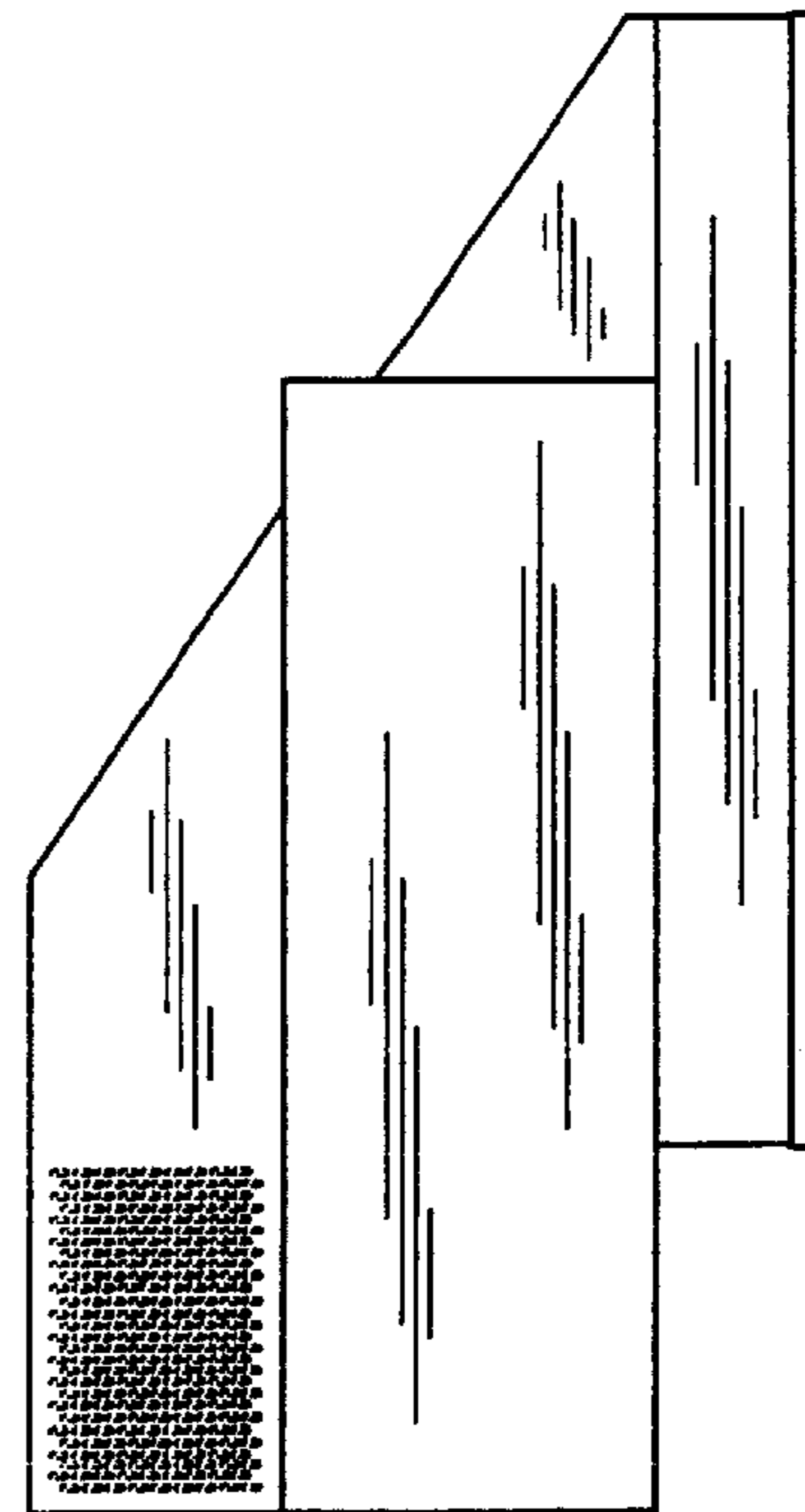

FIG. 7

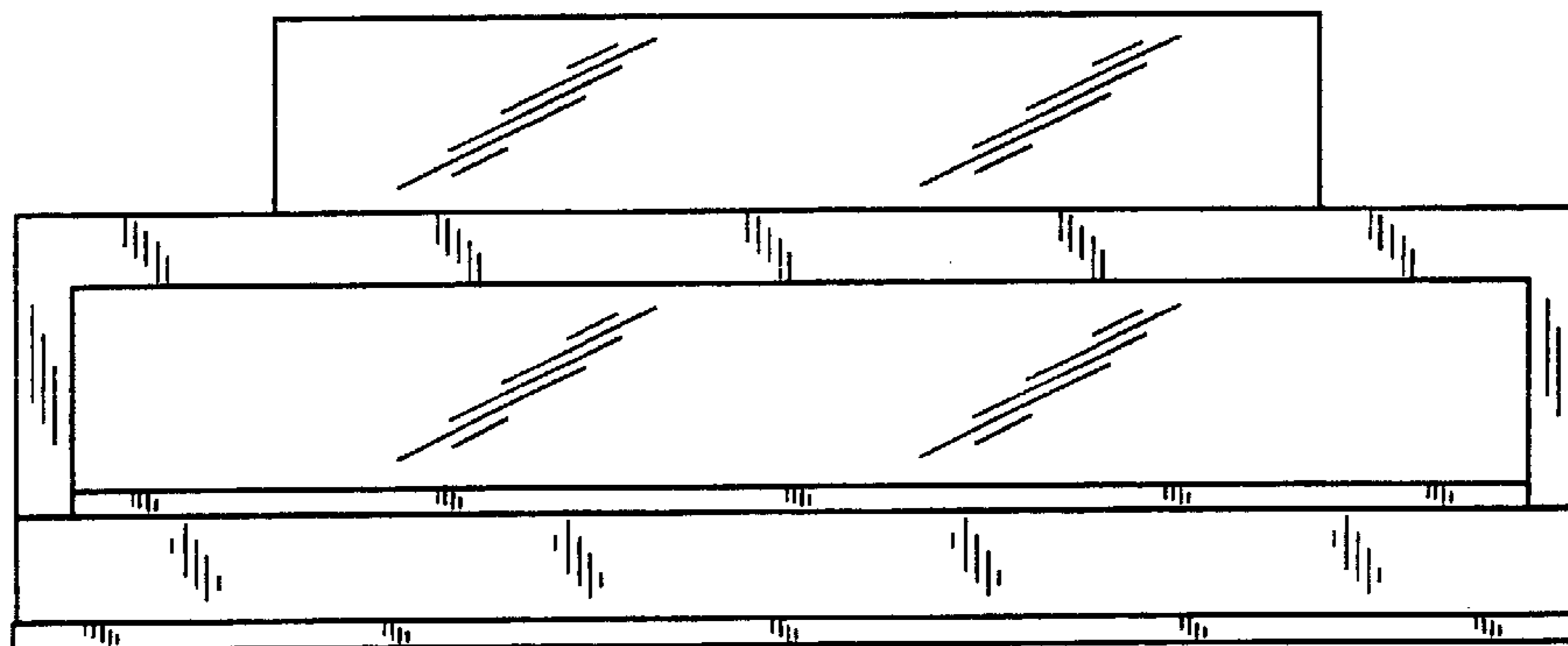

FIG. 8

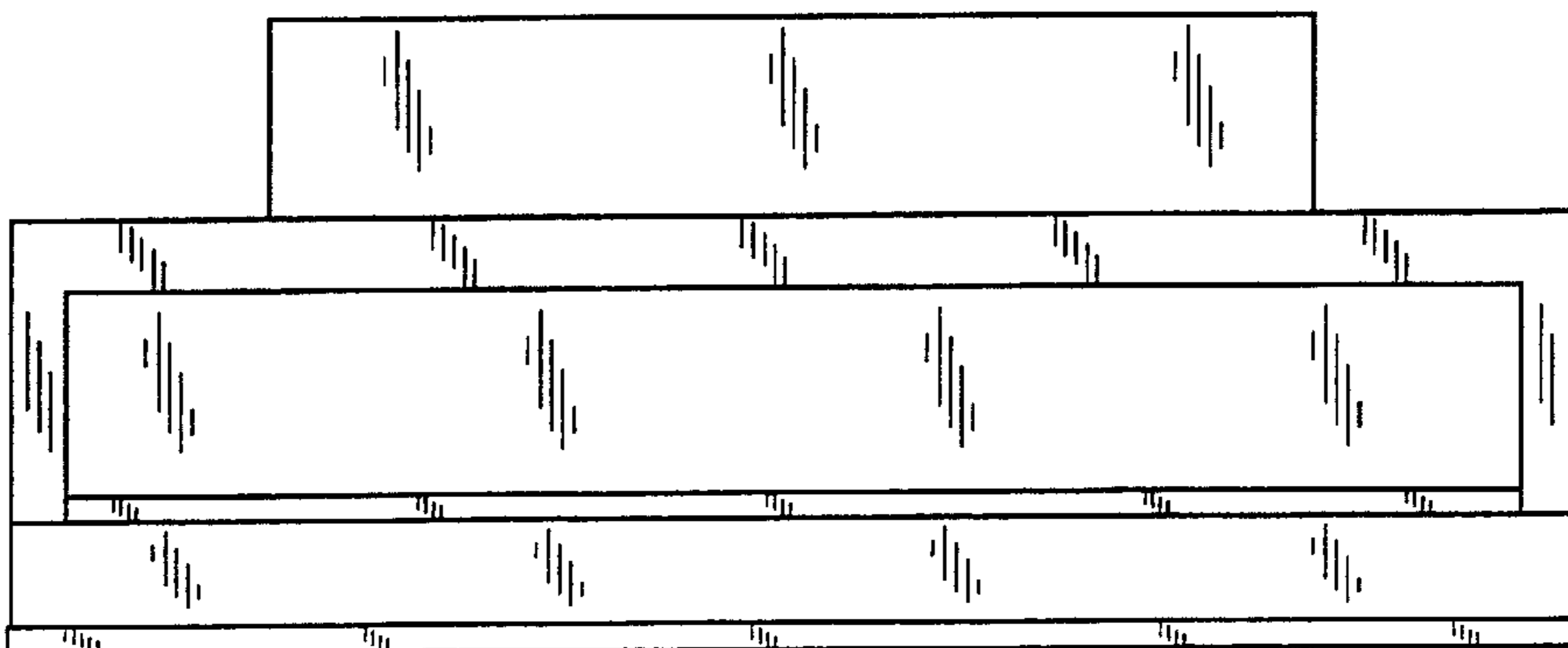

FIG. 9

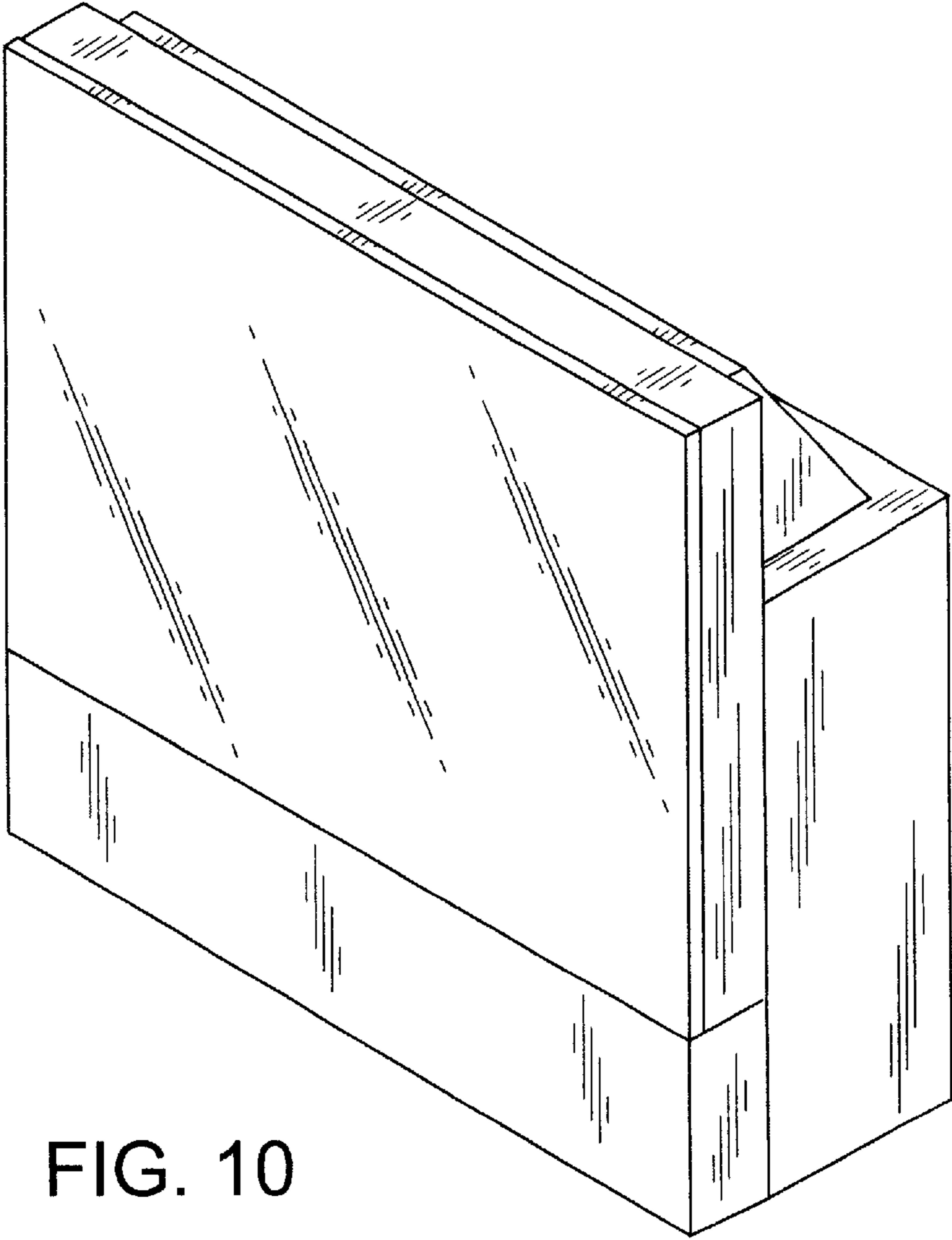

FIG. 10

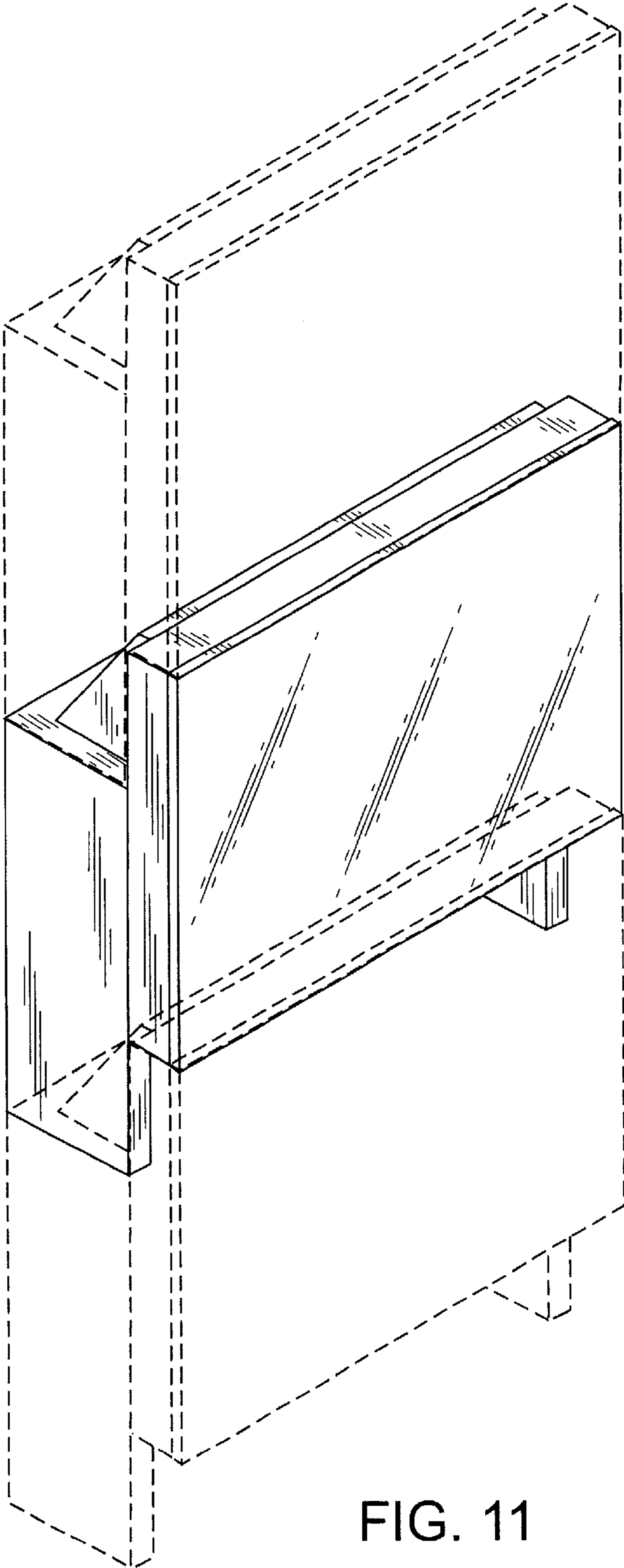

FIG. 11

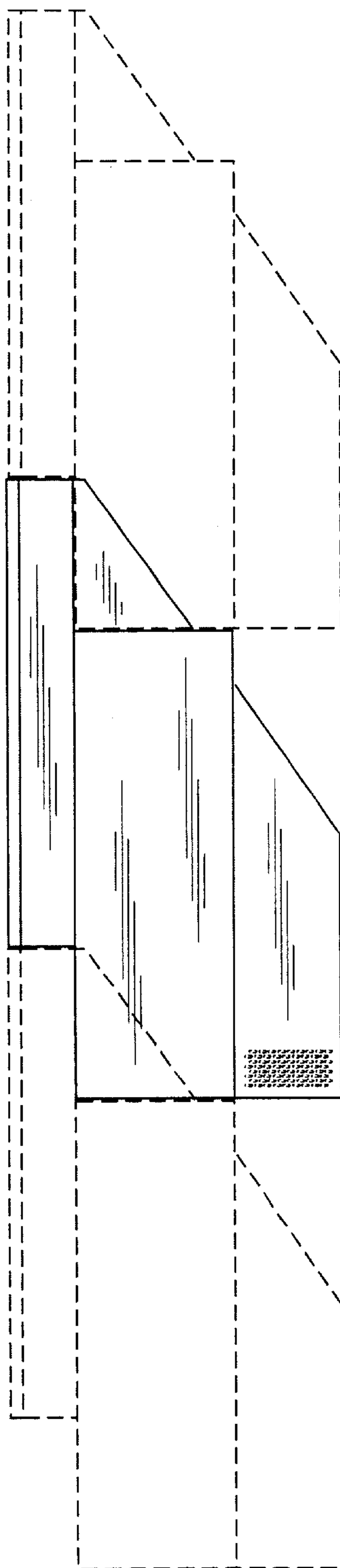

FIG. 12

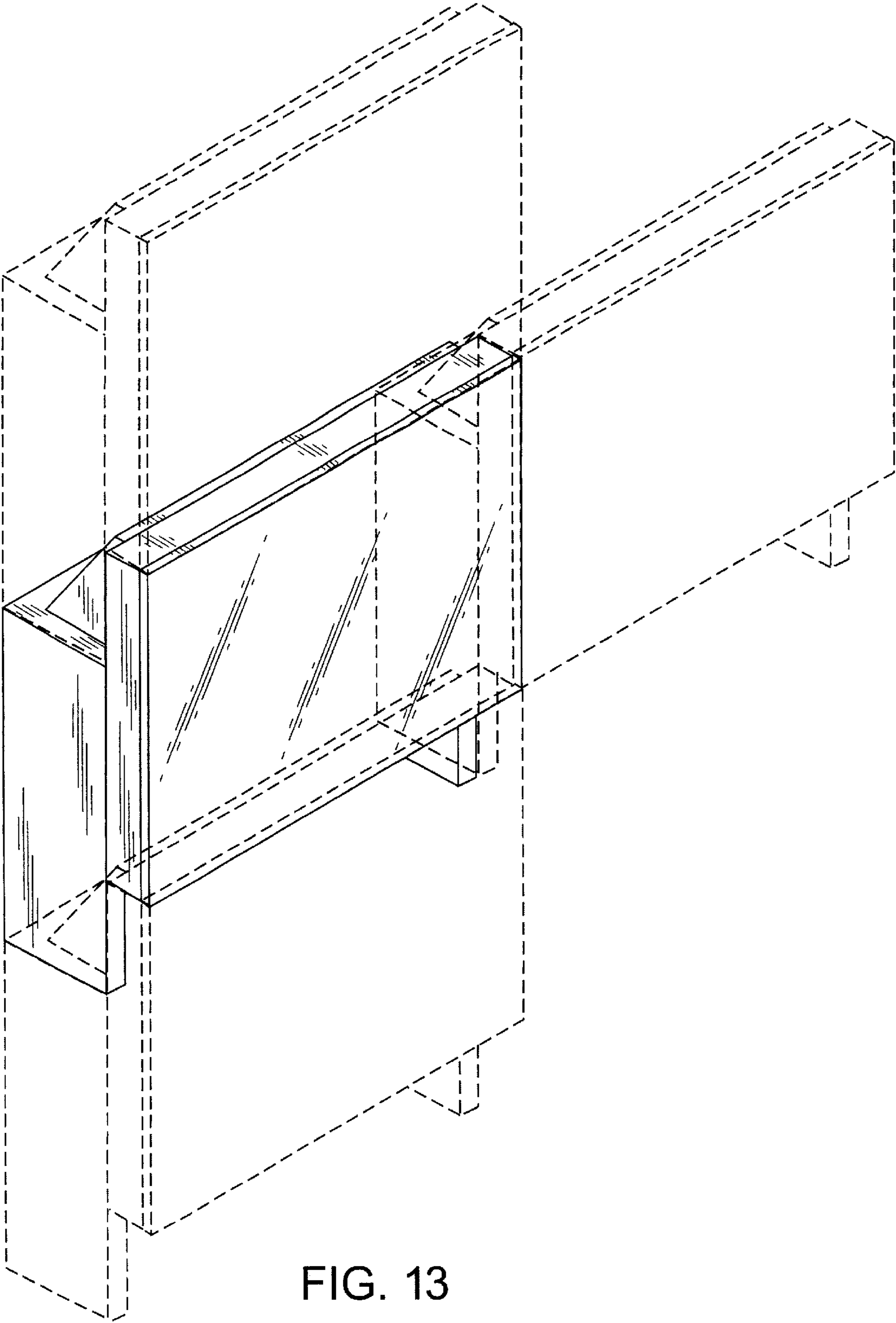

FIG. 13

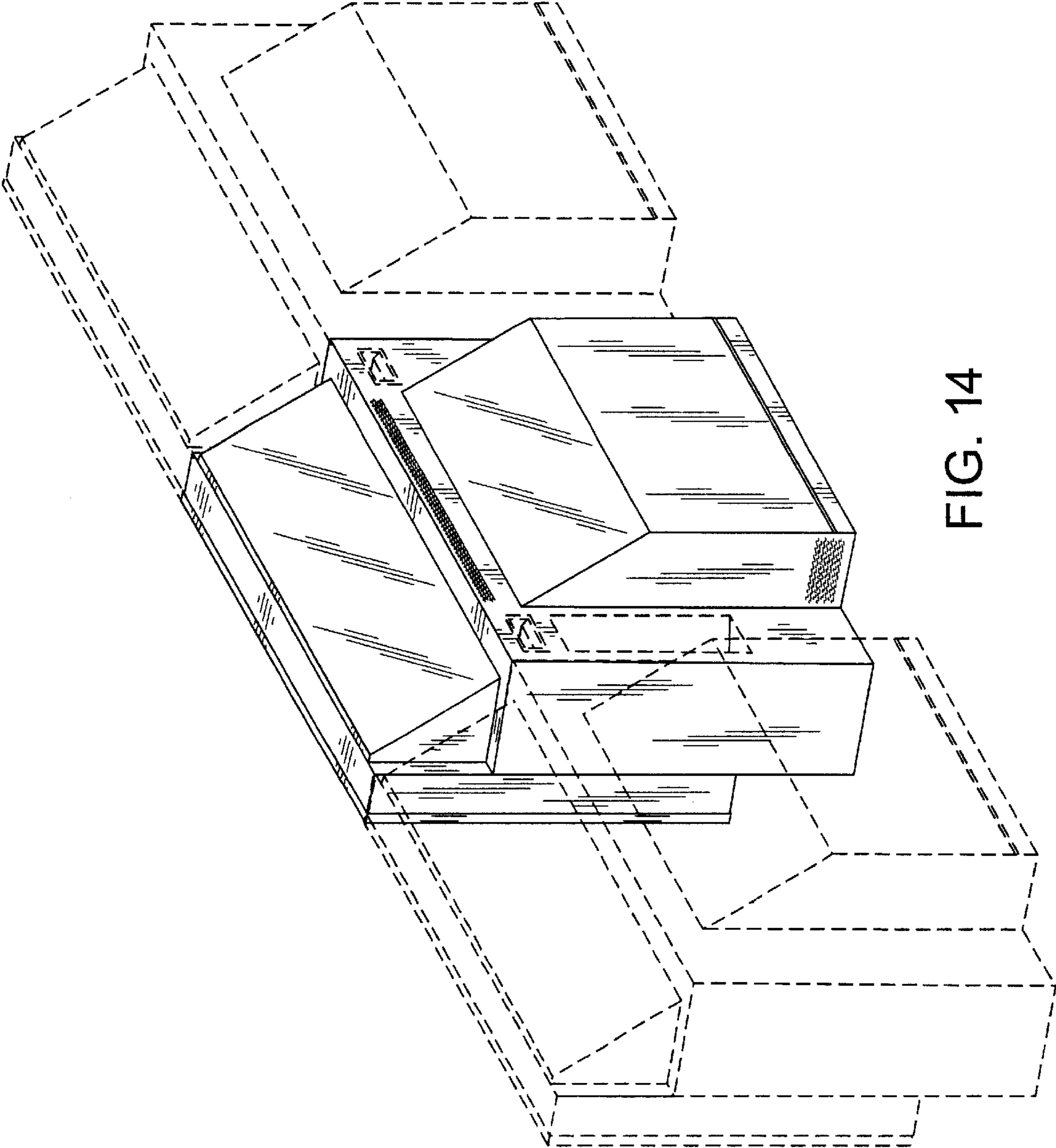

FIG. 14

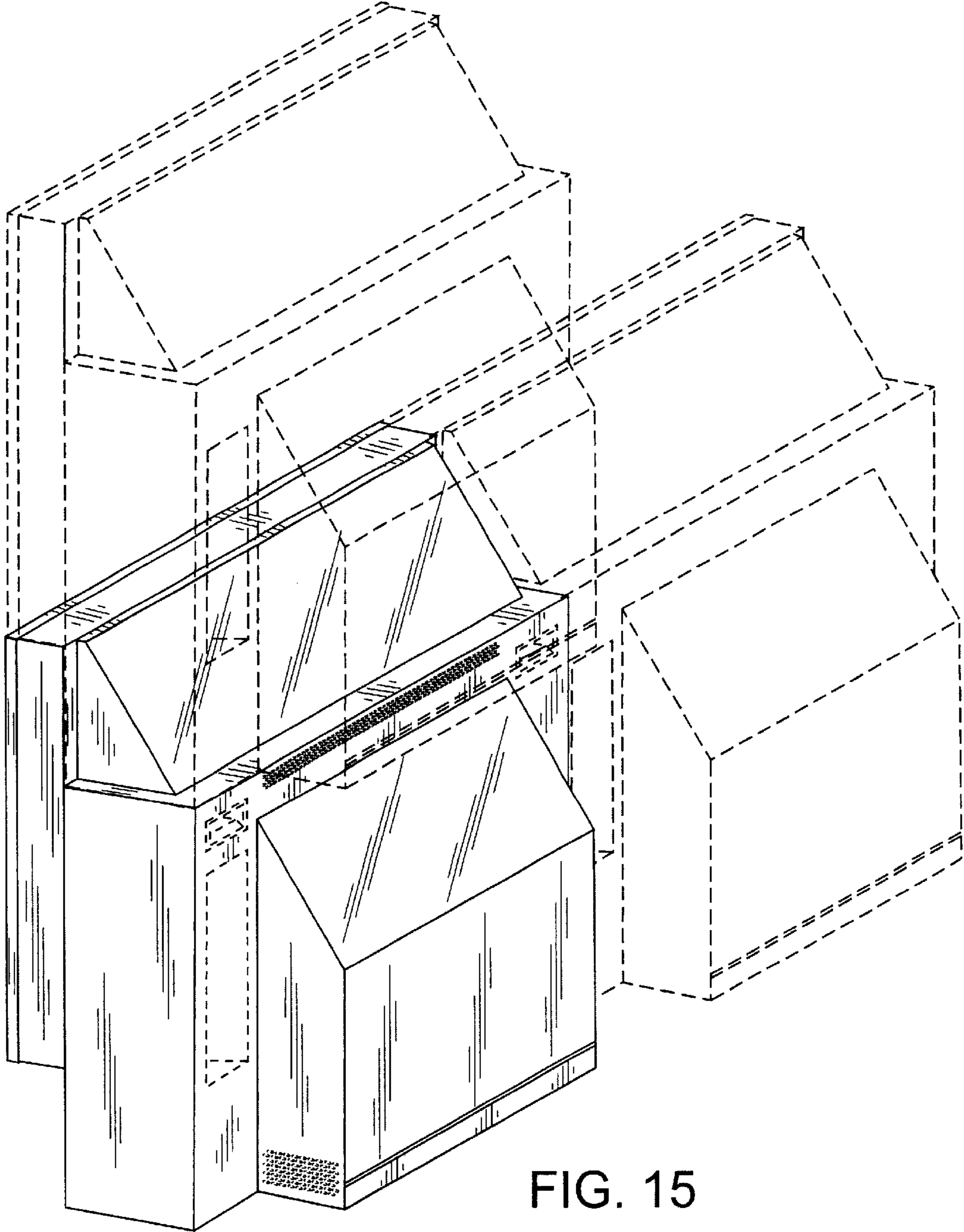

FIG. 15