



US00D536186S

(12) **United States Design Patent**
Crépeau et al.

(10) **Patent No.:** **US D536,186 S**

(45) **Date of Patent:** **** Feb. 6, 2007**

(54) **SEAT FOR A VEHICLE**

(75) Inventors: **Jean-Philippe Crépeau**, Bromont (CA); **Stéphane Sanschagrín**, St-Hyacinthe (CA)

(73) Assignee: **Bombardier Recreational Products Inc.**, Valcourt (CA)

(**) Term: **14 Years**

(21) Appl. No.: **29/239,213**

(22) Filed: **Sep. 28, 2005**

(51) **LOC (8) Cl.** **06-01**

(52) **U.S. Cl.** **D6/356**

(58) **Field of Classification Search** D6/333-336, D6/340, 349, 354, 356, 364-367, 374, 375, D6/379, 500-502; D12/107; 297/257, 313, 297/301.3, 391, 320, 325, 353, 464, 423.11, 297/452.26, 452.41

See application file for complete search history.

(56) **References Cited**

U.S. PATENT DOCUMENTS

D36,985	S	*	6/1904	Davis	D6/356
2,281,038	A	*	4/1942	Jones	297/353
D148,922	S	*	3/1948	Fleischer	D6/356
D183,149	S	*	7/1958	Simons et al.	D6/356
3,376,070	A	*	4/1968	Johnson	297/452.26
D226,589	S	*	3/1973	Svehla	D6/356
4,000,925	A	*	1/1977	Doerr et al.	297/301.3
4,003,599	A	*	1/1977	Takamatsu	297/391

D260,065	S	*	8/1981	Petersen	D6/379
D296,047	S	*	6/1988	Kucera et al.	D6/333
D318,112	S	*	7/1991	Tempereau Jacques	D6/375
5,102,192	A	*	4/1992	Barile, Sr.	297/257
5,486,035	A	*	1/1996	Koepke et al.	297/320
5,490,717	A	*	2/1996	Greene	297/452.41
5,590,930	A	*	1/1997	Glockl	297/313
5,599,063	A	*	2/1997	Lister et al.	297/325
D471,041	S	*	3/2003	Passwater	D6/501
7,070,241	B2	*	7/2006	Saulnier et al.	297/423.11
2005/0001466	A1	*	1/2005	Zambelli et al.	297/464

* cited by examiner

Primary Examiner—Mimosa De

(74) *Attorney, Agent, or Firm*—Osler, Hoskin & Harcourt LLP

(57) **CLAIM**

The ornamental design for a seat for a vehicle, as shown and described.

DESCRIPTION

FIG. 1 is a right side elevational view of a seat for a vehicle according to our design;

FIG. 2 is a left side elevational view thereof;

FIG. 3 is a front elevational view thereof;

FIG. 4 is a rear view thereof;

FIG. 5 is a top view thereof; and,

FIG. 6 is a bottom view thereof.

Throughout the Figures, broken lines showing structure are for illustrative purposes only and form no part of the claimed design.

1 Claim, 6 Drawing Sheets

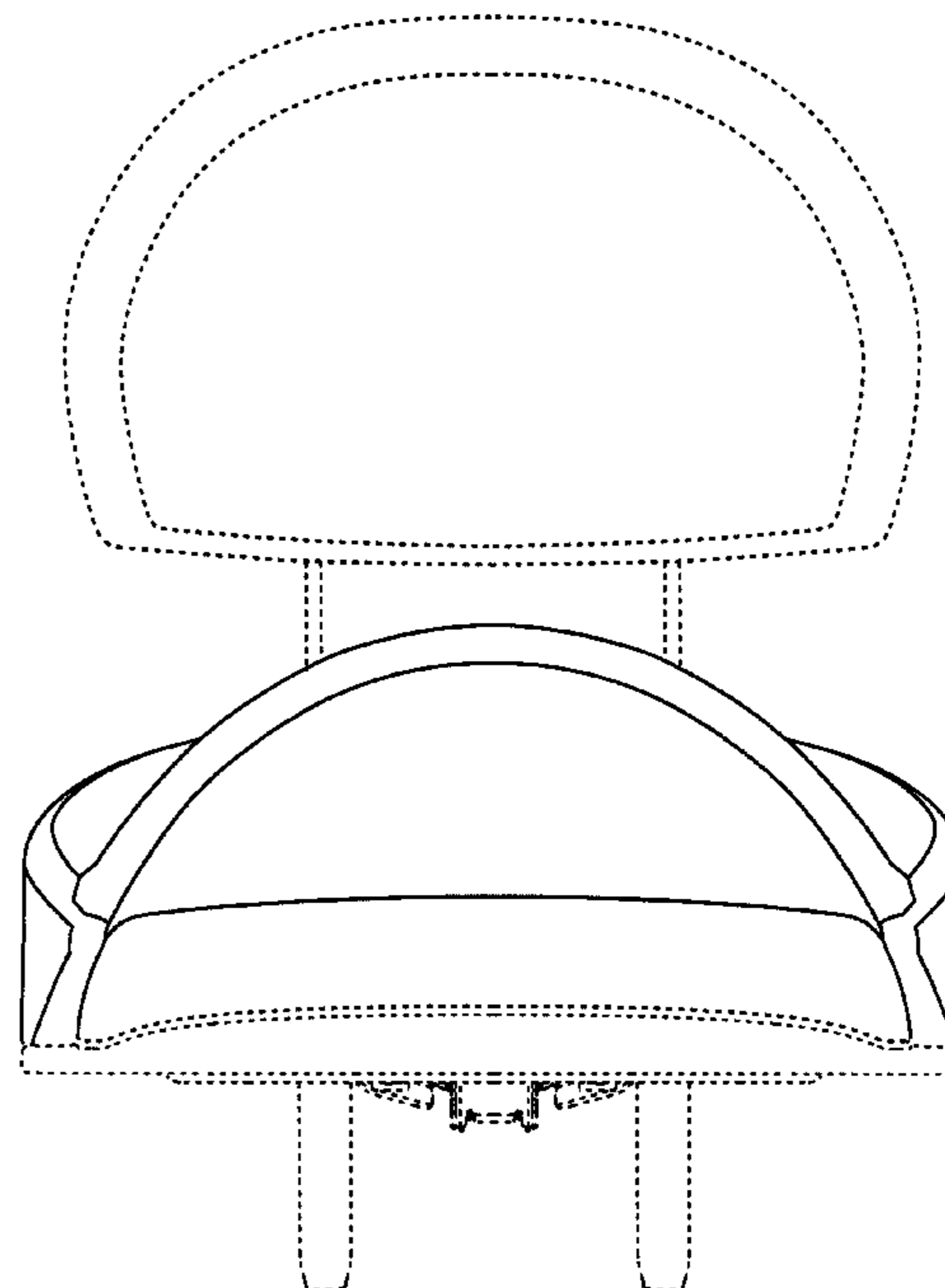
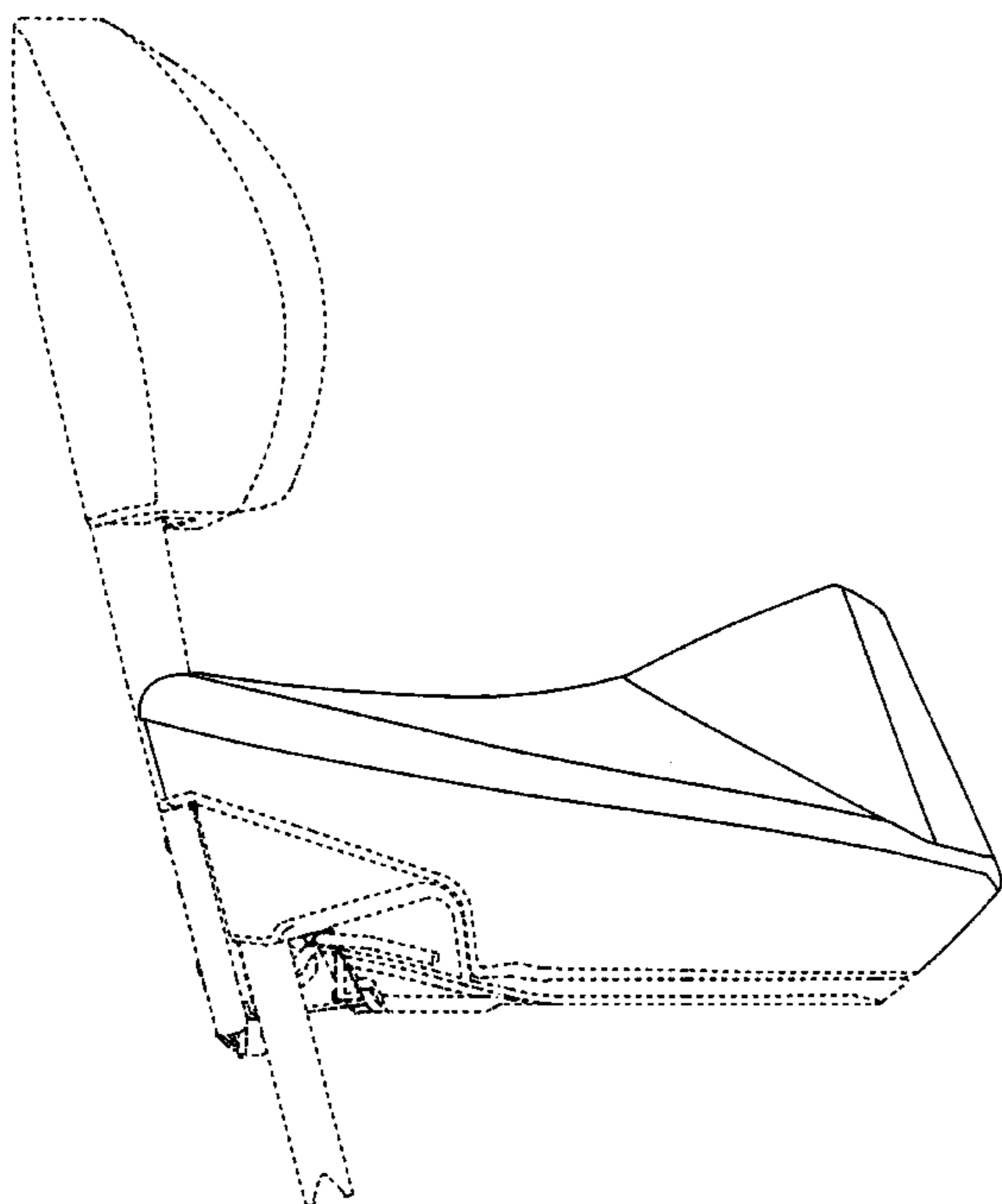

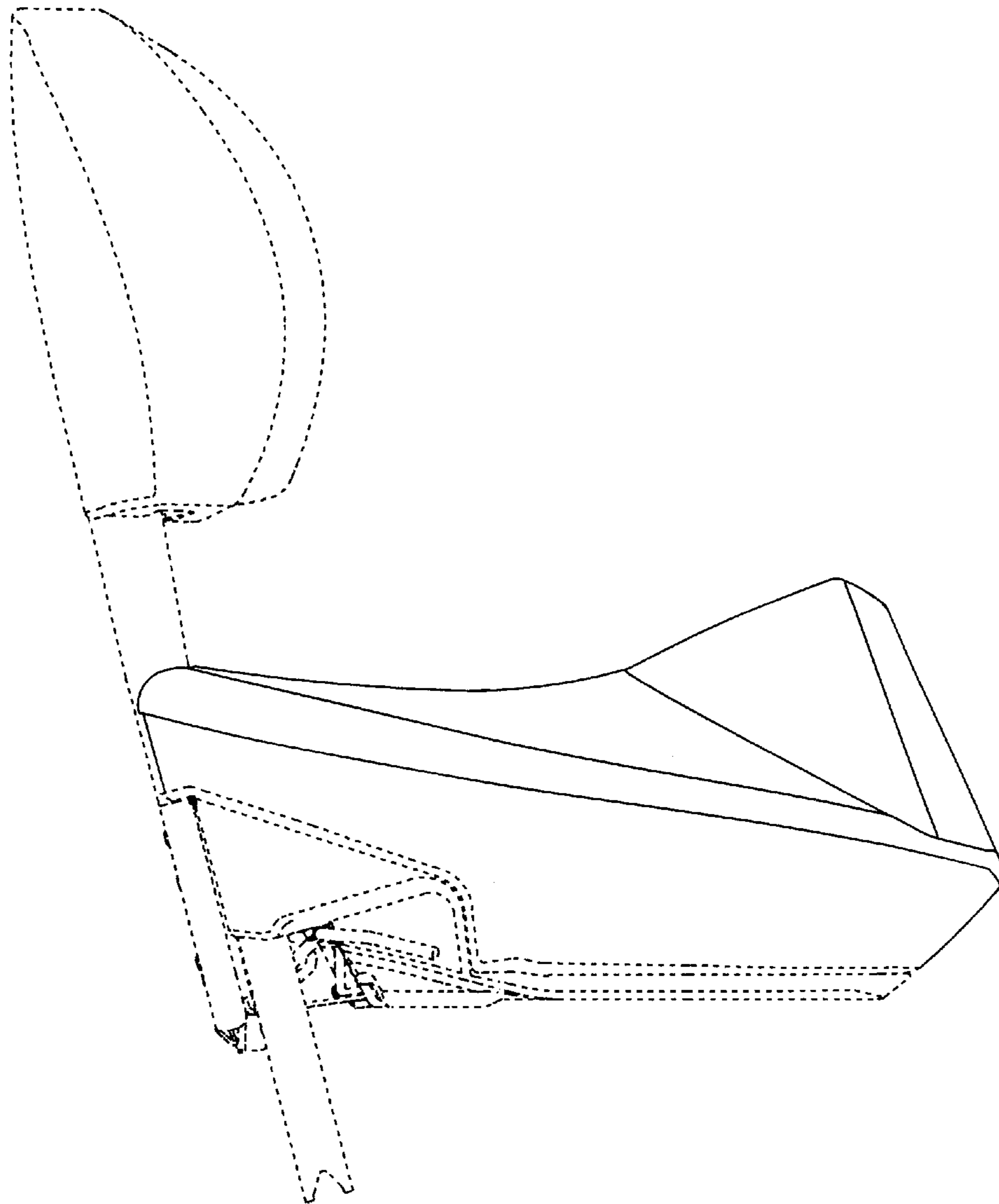

FIG. 1

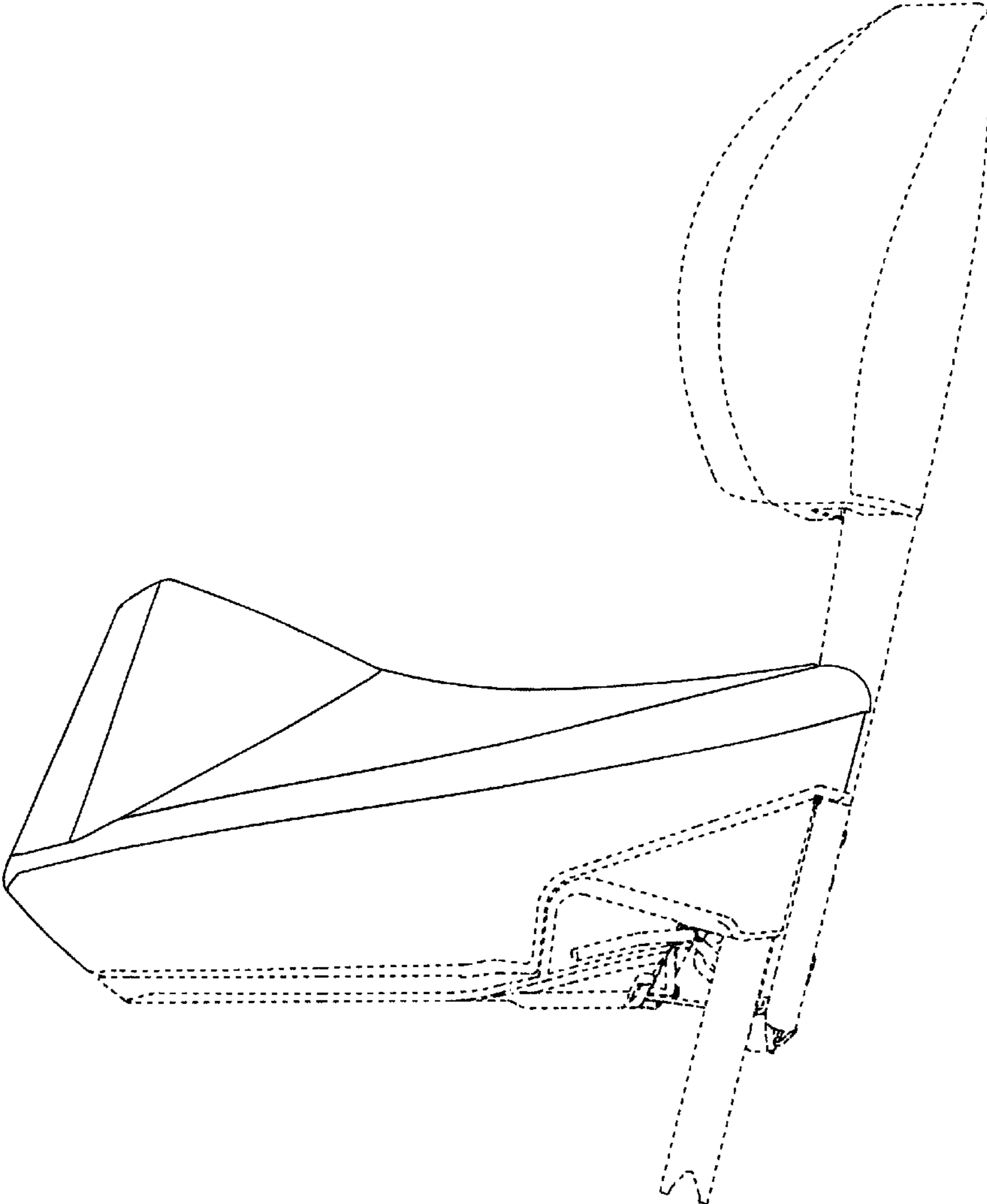

FIG. 2

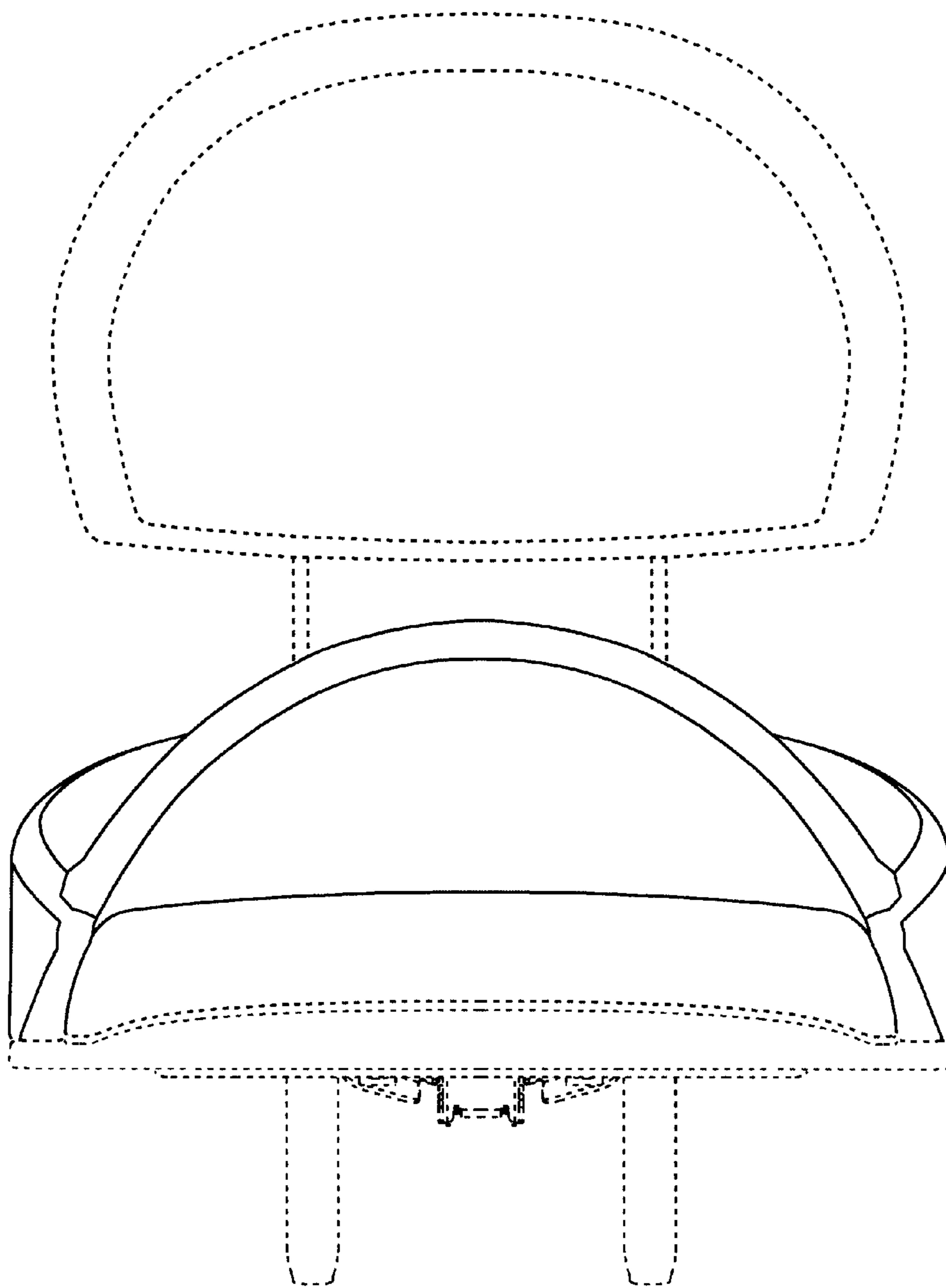

FIG. 3

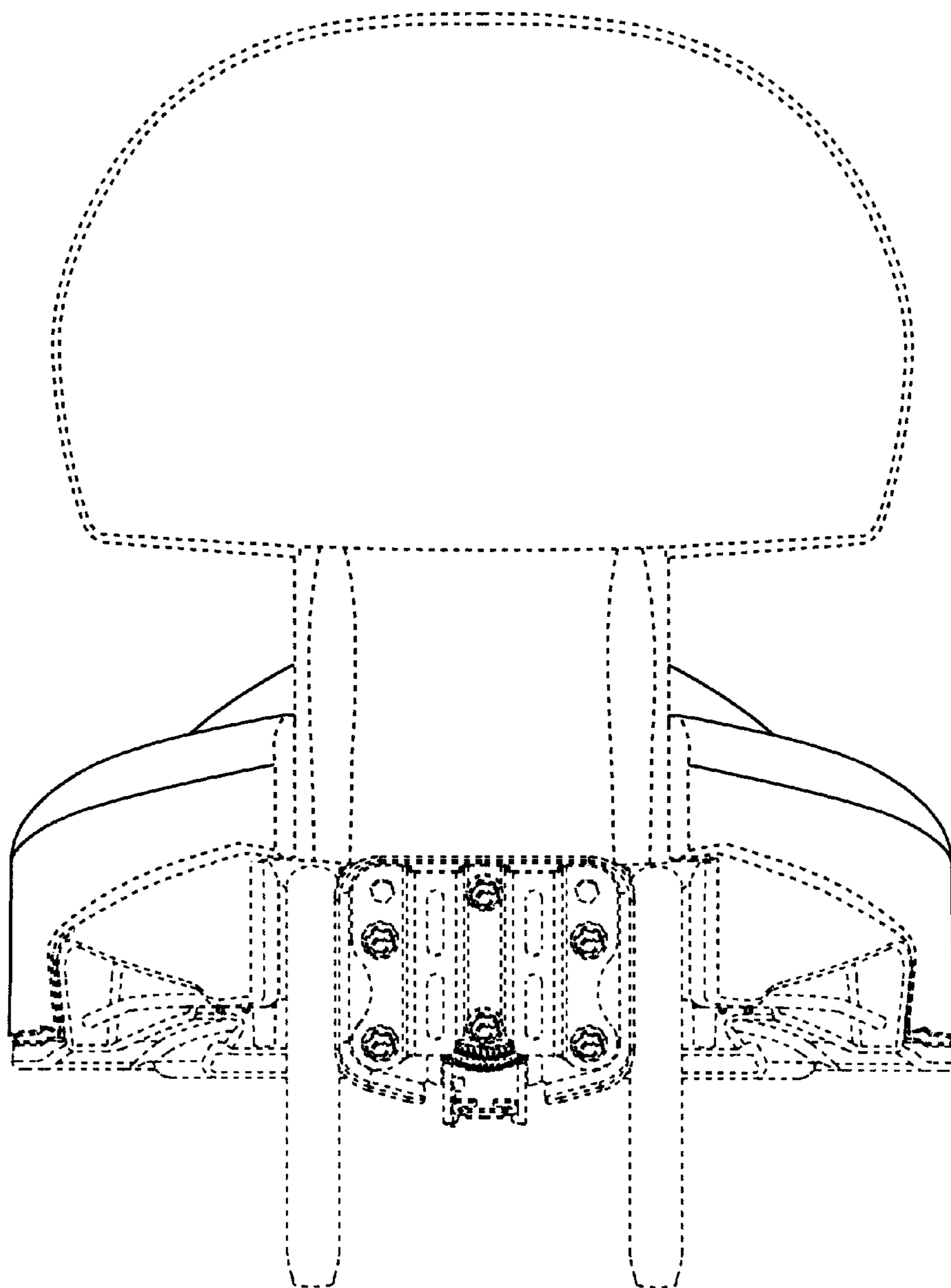

FIG. 4

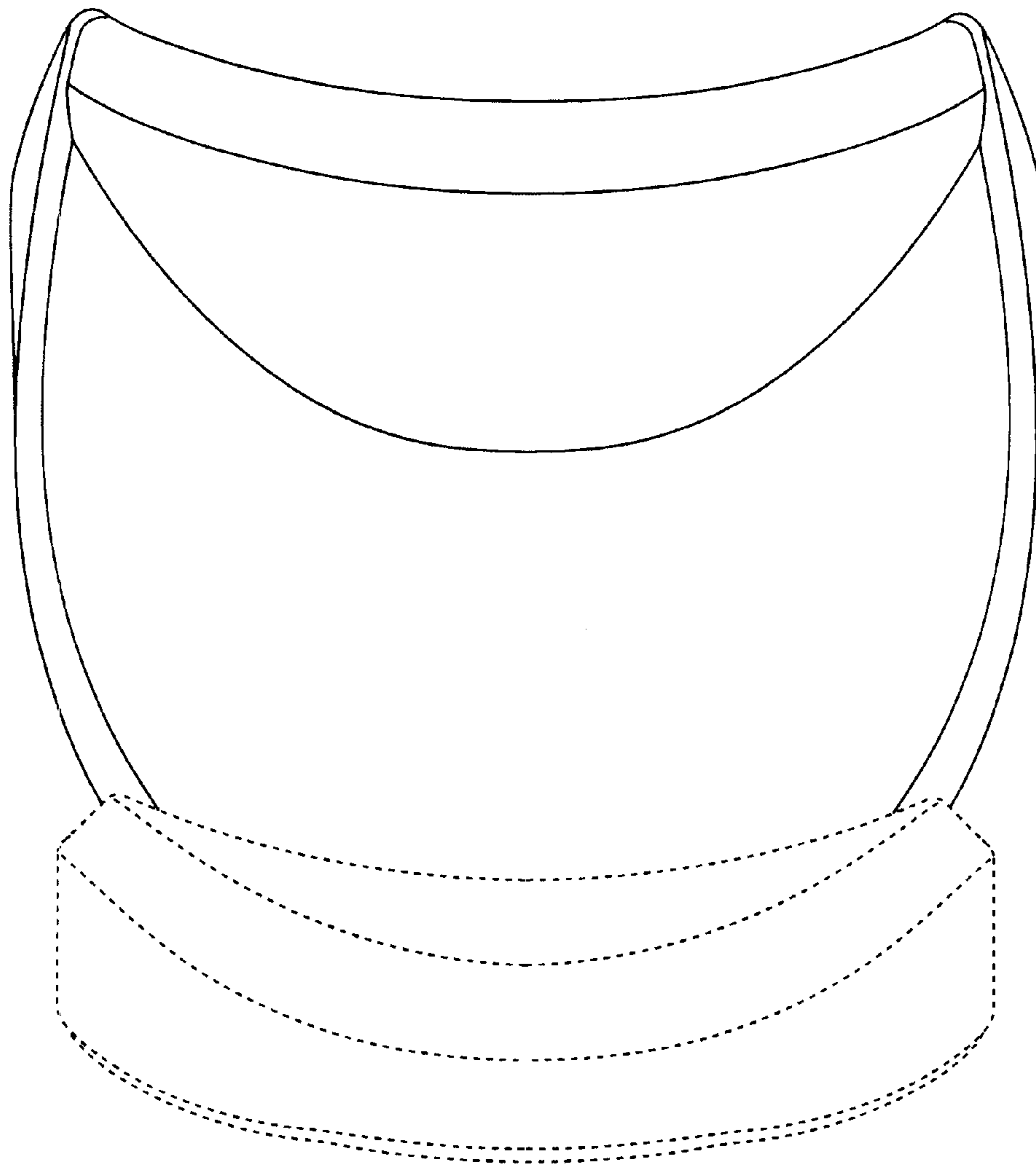

FIG. 5

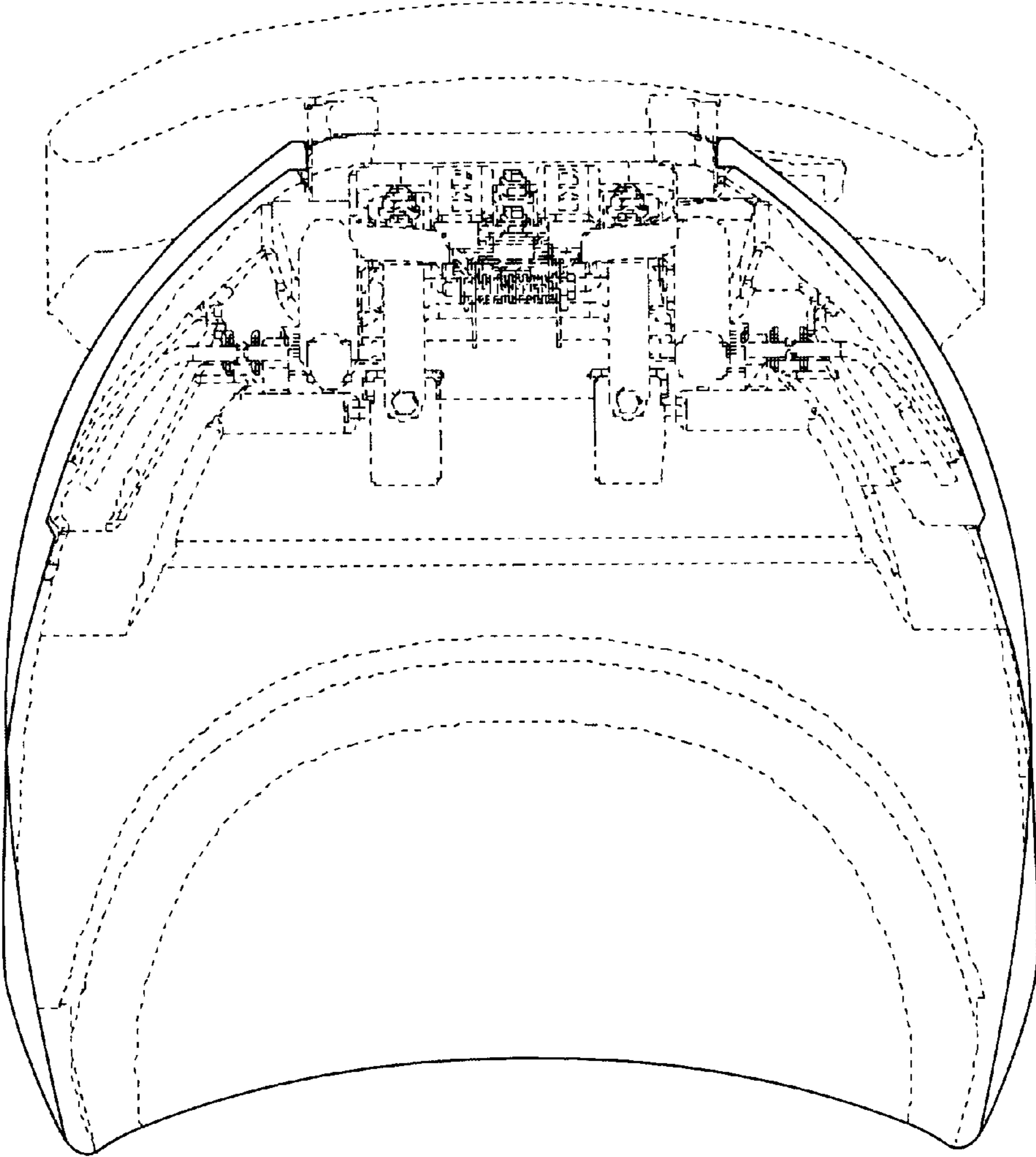

FIG. 6