



US00D536051S

(12) **United States Design Patent** (10) **Patent No.:** **US D536,051 S**
Hernandez, Jr. (45) **Date of Patent:** **** Jan. 30, 2007**

(54) **COMBINED DETACHABLE BASEBALL BASE AND SUPPORT UNIT**

(76) Inventor: **Luis Hernandez, Jr.**, 2100 Bonnie La., Waukesha, WI (US) 53188

(**) Term: **14 Years**

(21) Appl. No.: **29/253,862**

(22) Filed: **Feb. 14, 2006**

(51) **LOC (8) Cl.** **21-02**

(52) **U.S. Cl.** **D21/780**

(58) **Field of Classification Search** D21/698, D21/699, 706, 780; D6/352, 455, 486, 488, D6/495; 473/415-504

See application file for complete search history.

4,531,733 A * 7/1985 Hall 473/501
 4,542,901 A 9/1985 Fatool et al.
 4,723,779 A 2/1988 Hauser
 4,744,561 A 5/1988 Hall
 D297,989 S * 10/1988 DeLuca D6/480
 4,830,368 A 5/1989 Green et al.
 4,976,430 A 12/1990 Brandon
 5,000,447 A 3/1991 Bartoli
 5,290,028 A 3/1994 Bartoli
 5,415,395 A 5/1995 Bartoli
 5,456,460 A * 10/1995 Larsen 473/499
 5,564,695 A 10/1996 Christensen
 D394,564 S * 5/1998 Haney D6/455
 5,772,539 A 6/1998 Hall
 6,077,175 A 6/2000 Fearnow

* cited by examiner

Primary Examiner—Catherine Tuttle
 (74) *Attorney, Agent, or Firm*—Ryan Kromholz & Manion, S.C.

(56) **References Cited**
 U.S. PATENT DOCUMENTS

75,076 A * 3/1868 Taylor 473/499
 D37,304 S * 1/1905 Palmer D6/455
 1,244,044 A 10/1917 Falconer, Sr.
 2,046,126 A 6/1936 Latina
 2,103,148 A 12/1937 Conrad
 2,275,547 A 3/1942 Mouch
 2,405,492 A 8/1946 Corbett
 3,204,958 A * 9/1965 Velasquez 473/499
 3,466,039 A 9/1969 Golomb
 3,508,747 A * 4/1970 Orsatti 473/499
 3,703,285 A 11/1972 Perry
 D225,935 S * 1/1973 Kienel D6/486
 3,971,558 A 7/1976 Gardetto
 4,266,768 A 5/1981 Hall
 4,398,715 A 8/1983 Hall
 4,405,130 A 9/1983 Mullany
 4,448,414 A 5/1984 Gutierrez
 4,529,199 A 7/1985 Fatool

(57) **CLAIM**

The ornamental design for a combined detachable baseball base and support unit, as shown and described.

DESCRIPTION

FIG. 1 is a perspective exploded view of a combined detachable baseball base and support unit of the present invention;
 FIG. 2 is a perspective view of the assembled design;
 FIG. 3 is an elevational view of the rear and side of FIG. 1;
 FIG. 4 is an elevational view of the front of FIG. 1;
 FIG. 5 is a top view thereof; and,
 FIG. 6 is a bottom view thereof.
 The features shown in broken lines are for illustrative purposes only and form no part of the claimed design.

1 Claim, 3 Drawing Sheets

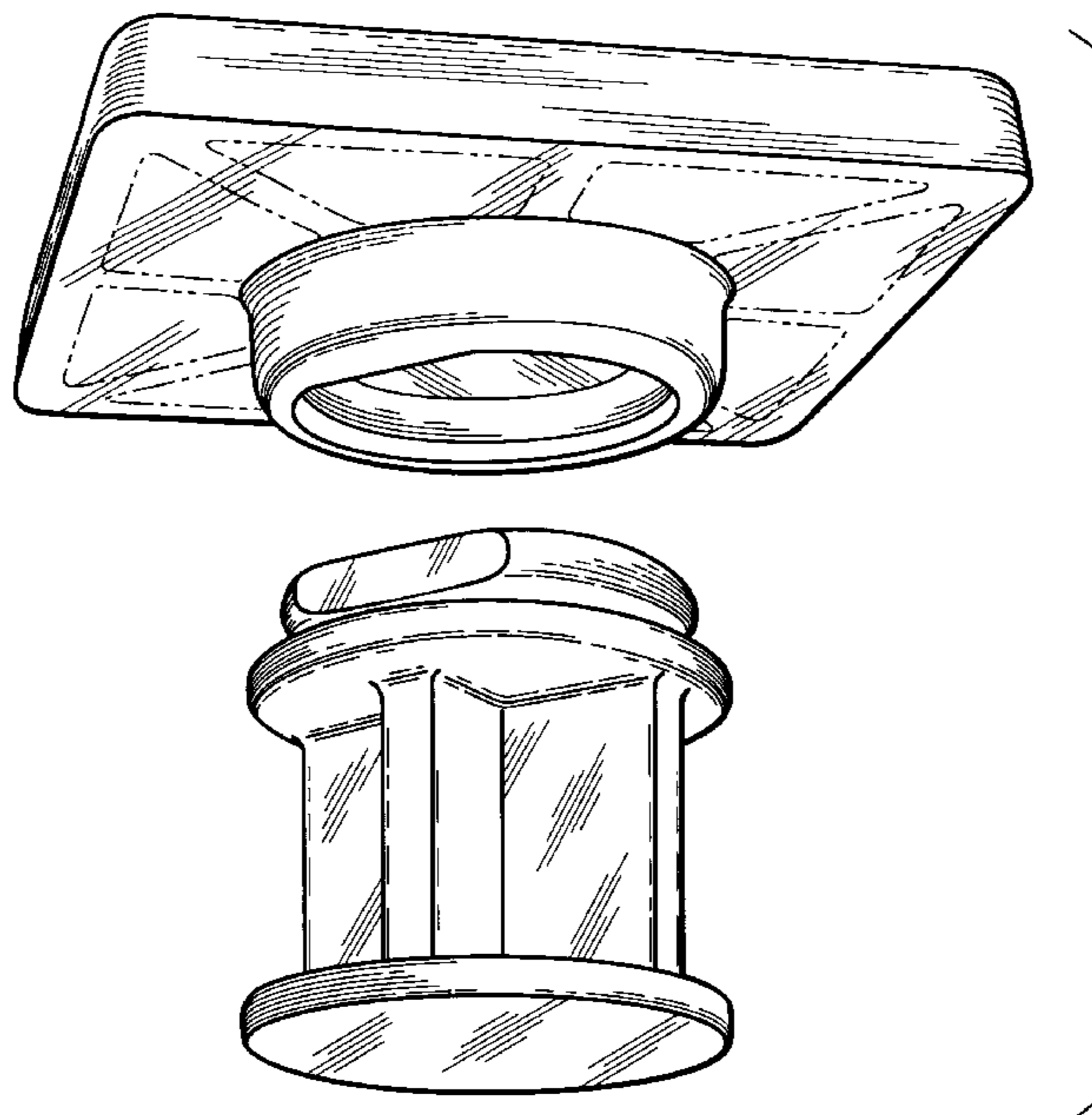

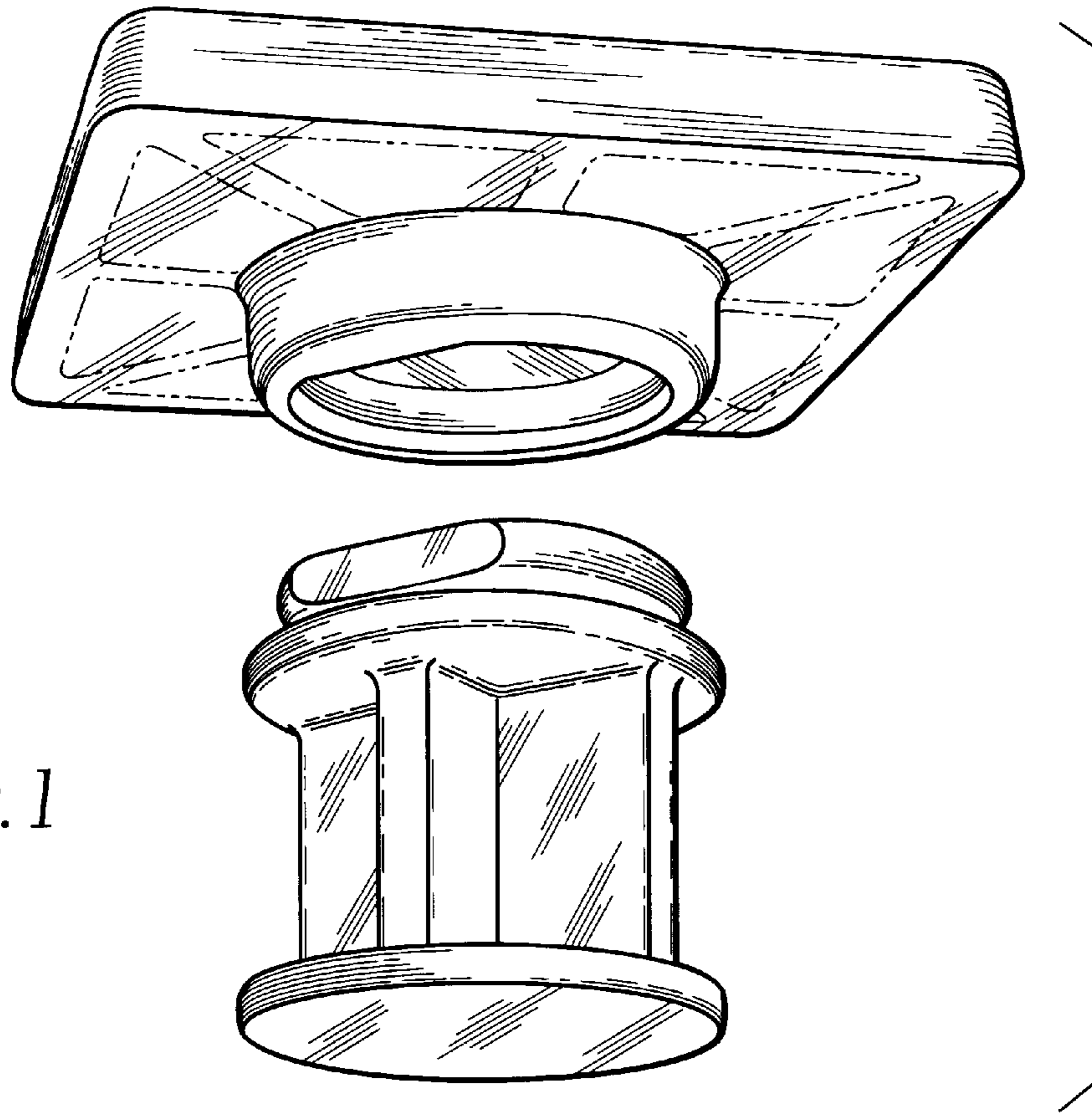

Fig. 1

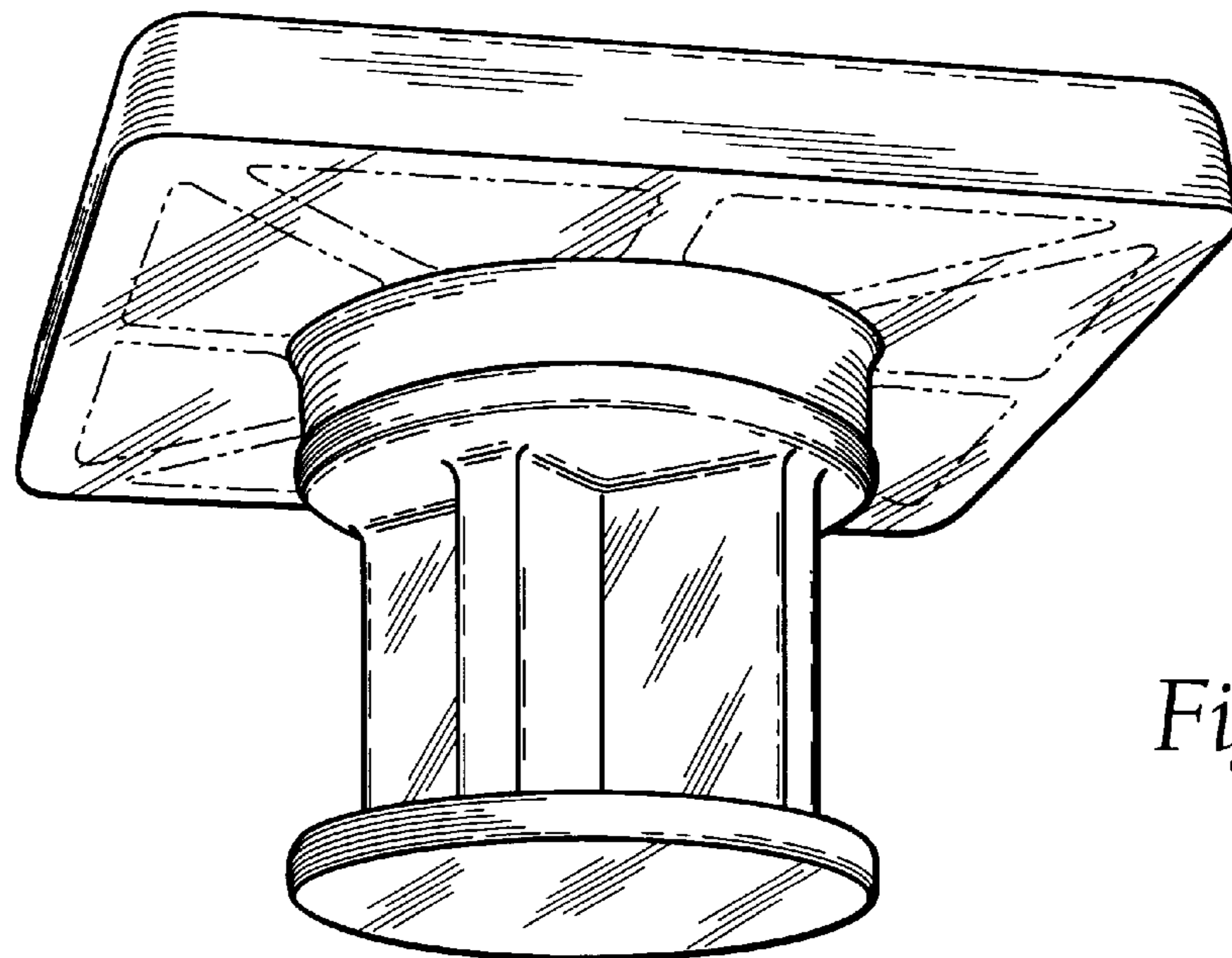

Fig. 2

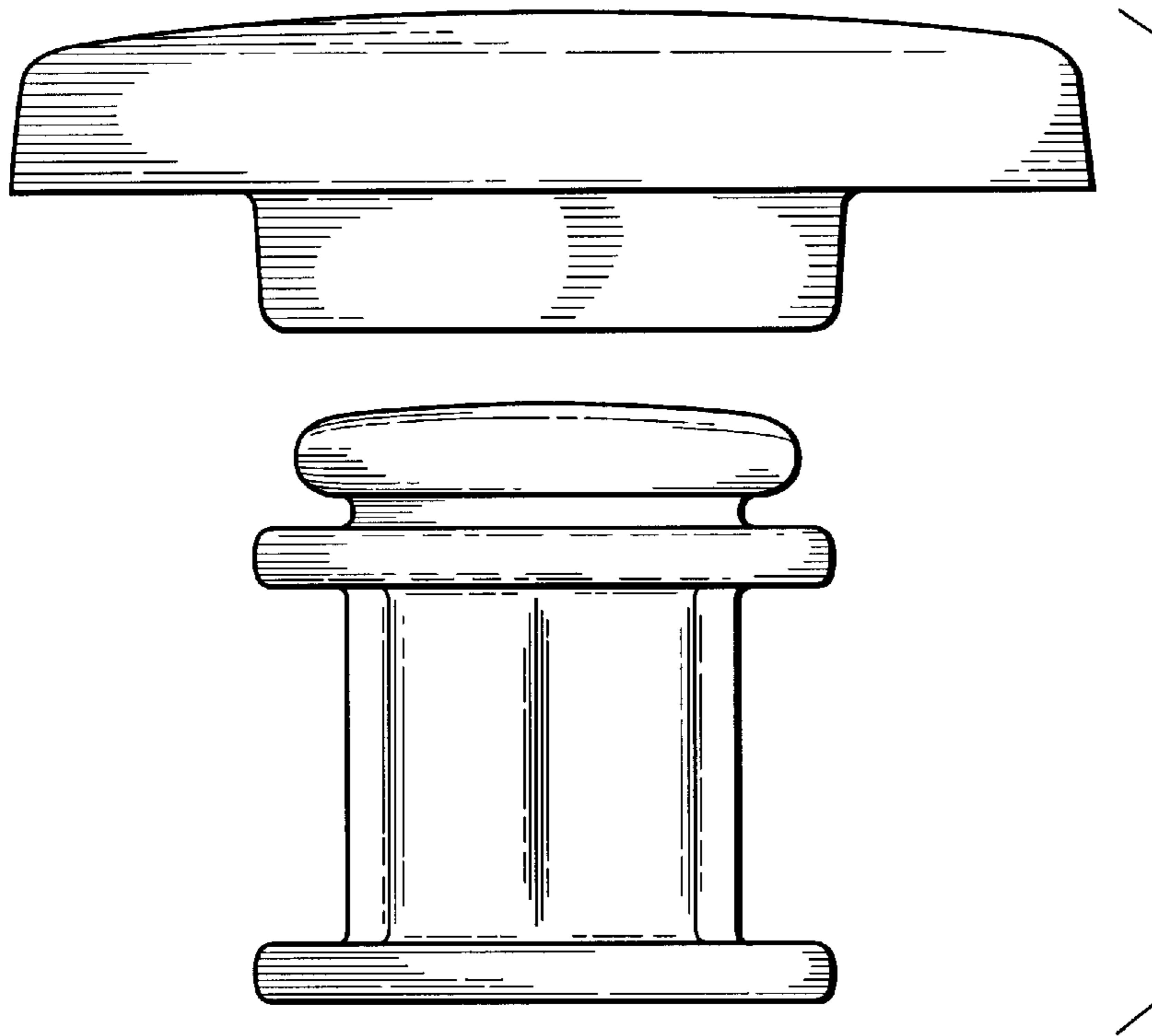

Fig. 3

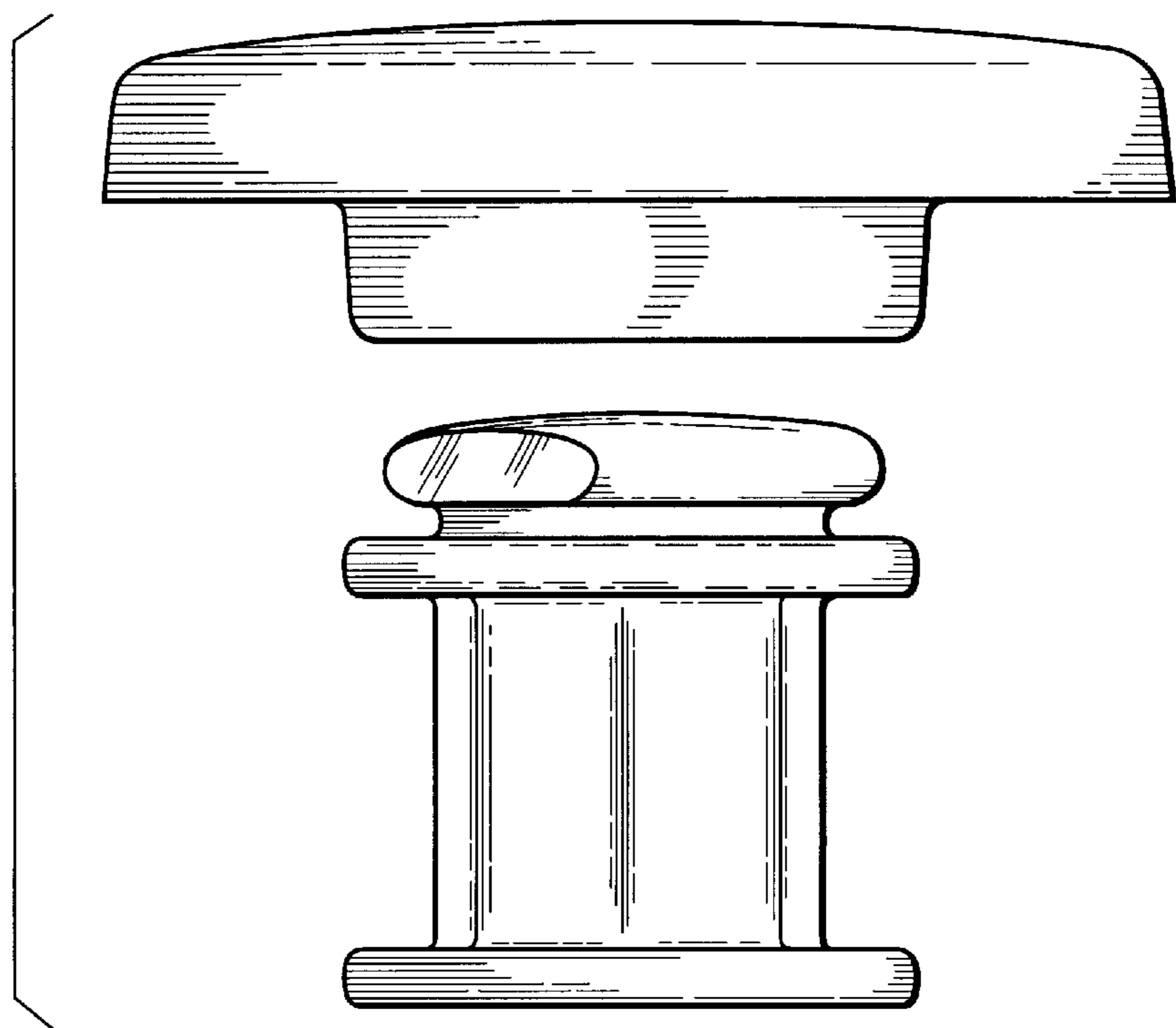

Fig. 4

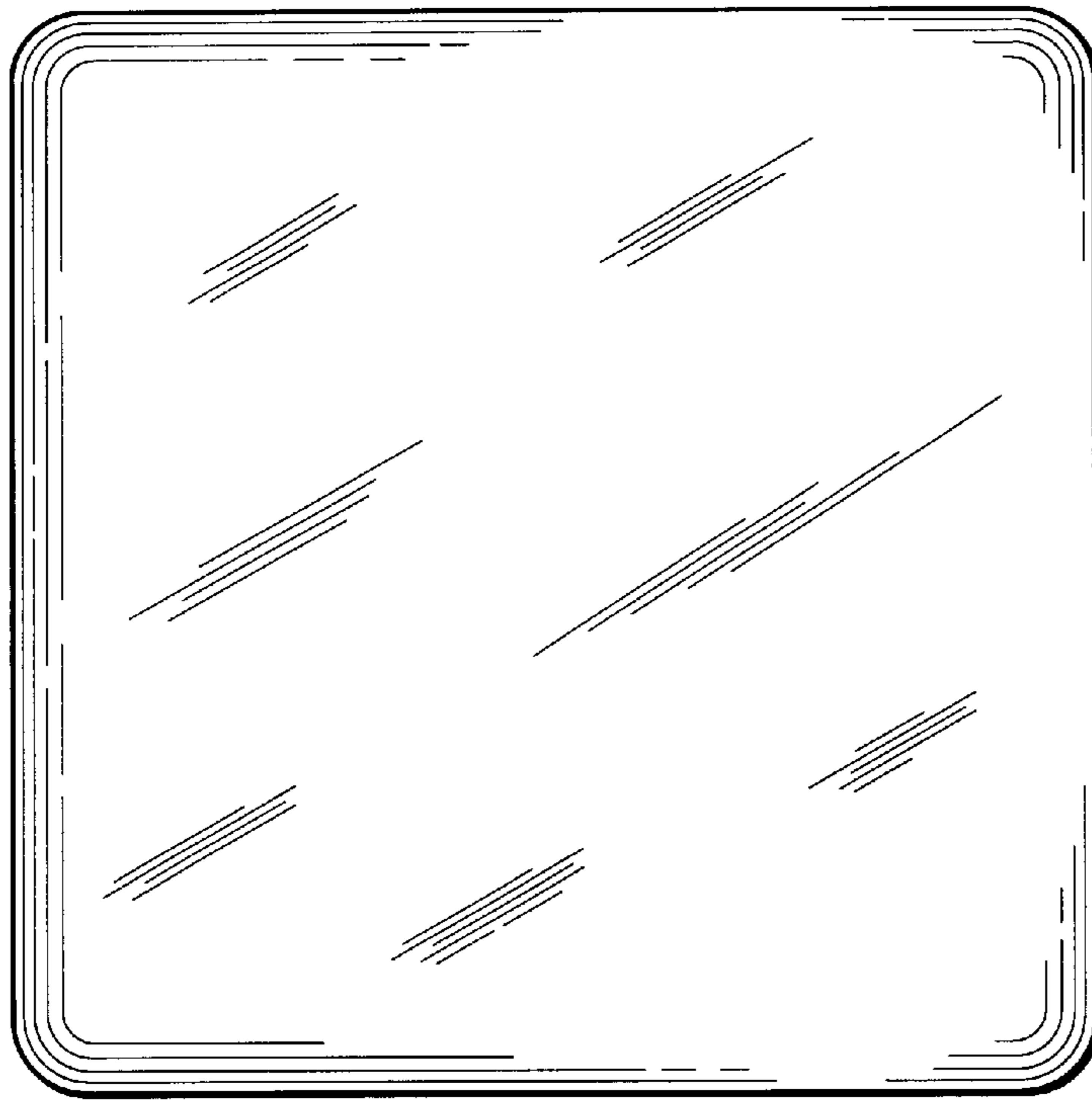

Fig. 5

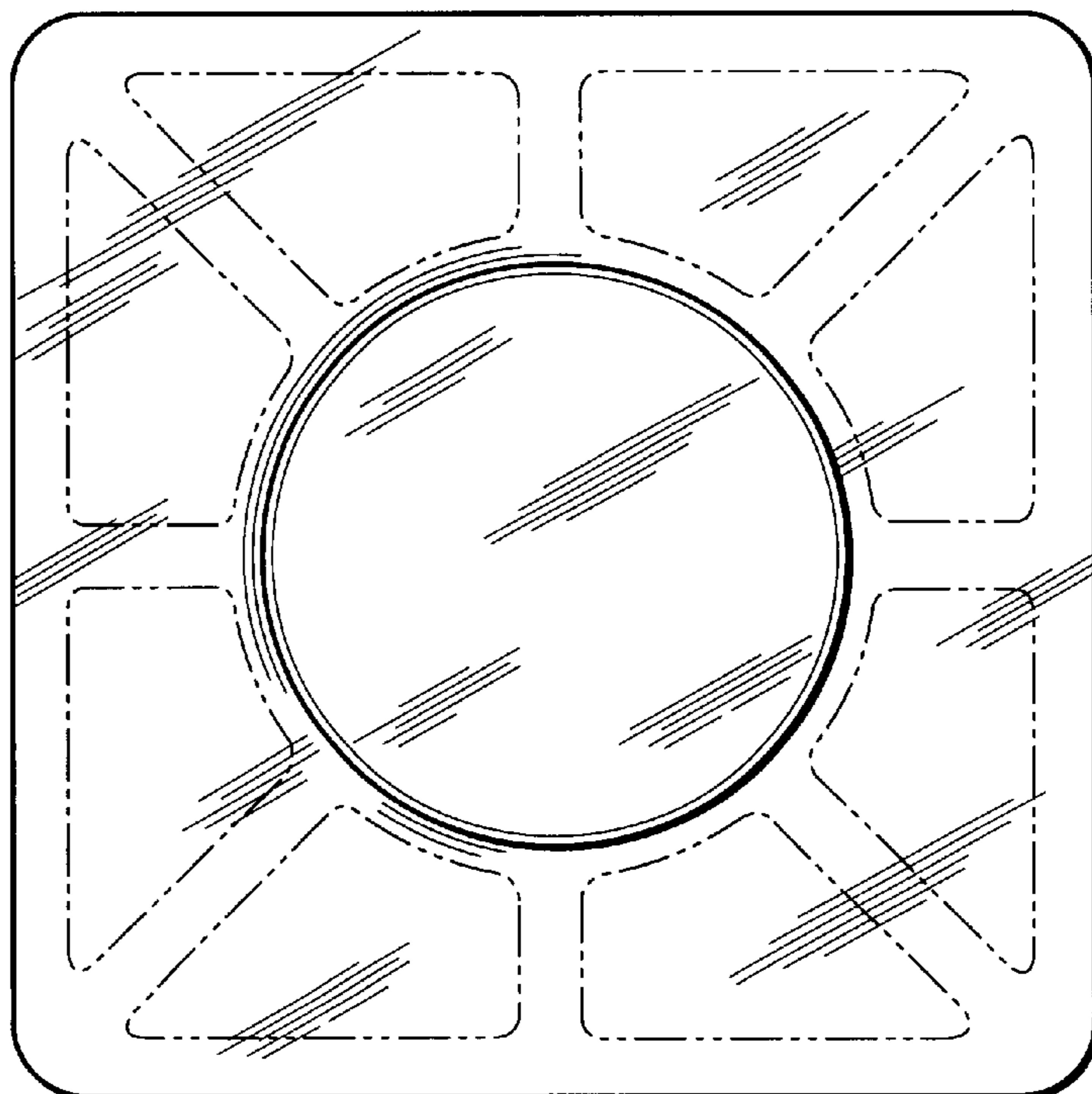

Fig. 6