



US00D535589S

(12) **United States Design Patent**
Lau et al.

(10) **Patent No.:** **US D535,589 S**
(45) **Date of Patent:** **** Jan. 23, 2007**

(54) **VEHICLE GRILLE**

(75) Inventors: **Chelsia Lau**, Ann Arbor, MI (US);
Patrick Schiavone, Birmingham, MI
(US); **Jeffrey Nowak**, Huntington
Woods, MI (US); **Mark McChesney**,
Saline, MI (US)

(73) Assignee: **Ford Global Technologies, LLC**,
Dearborn, MI (US)

(**) Term: **14 Years**

(21) Appl. No.: **29/237,826**

(22) Filed: **Sep. 7, 2005**

(51) **LOC (8) Cl.** **12-16**

(52) **U.S. Cl.** **D12/163**

(58) **Field of Classification Search** D12/163,
D12/171, 90-92, 98, 169, 196; 180/68.1,
180/68.6; 296/194; 293/102, 113, 115
See application file for complete search history.

(56) **References Cited**

U.S. PATENT DOCUMENTS

D488,405 S	*	4/2004	Metros et al.	D12/98
D507,215 S	*	7/2005	Fukushima	D12/169
D507,770 S	*	7/2005	Minami	D12/163
D513,482 S	*	1/2006	Hattori	D12/163
D514,480 S	*	2/2006	Yamaji et al.	D12/163
D517,449 S	*	3/2006	Depeyster et al.	D12/98
D519,890 S	*	5/2006	Sakae	D12/163
D520,416 S	*	5/2006	Tomida et al.	D12/163
D521,903 S	*	5/2006	Matei et al.	D12/91

OTHER PUBLICATIONS

1999 North American Auto Show (Detroit), Explorer Sport Trac, stock photo, date unknown.

2001 Auto Show (Geneva), Explorer, stock photo, date unknown.

2002 North American Auto Show (Detroit), Explorer Sport Trac, stock photo, date unknown.

TheCarConnection.com, *Spy Shots: '06 Ford Explorer*. A fresh face for a middle-age warrior. http://www.thecarconnecton.com/Enthusiasts/Spy_Shots/Spy_Shots_06_Ford_Explorer.S178.A7402.html, Aug. 9, 2004.
Jalopnik, *Auto Week Reader Snaps Photo of '06 Explorer, or is that the '04?*, v 54, No. 33, p. 4, <http://www.jalopnik.com/cars/spy-photos/autoweek-reader-snaps-photo-of-06-explorer-or-is-that-the-04-019721.php>, Aug. 16, 2004.
Auto Week, *AW Spies*, v 54, No. 33, p. 4, Aug. 16, 2004.
Popular Mechanics, *Detroit Spy Report*, p. 40, Nov. 2004.
Popular Mechanics, *Detroit Spy*, http://www.popularmechanics.com/automotive/spy_reports/1318501.html, Jan. 3, 2005.
Auto Week, *Topic: 2006 Sport Trac photos*, <http://forums.autoweek.com/thread.jspa?forumID=31&threadID=11652&start=60&tstart=0>, Jan. 13, 2005.
Jalopnik, *Spy Photos: 2007 Ford Sport Track*, <http://www.jalopnik.com/cars/spy-photos/spy-photos-2007-ford-sport-trac-030973.php>, Jan. 24, 2005.

(Continued)

Primary Examiner—Melody N. Brown
(74) *Attorney, Agent, or Firm*—Damian Porcari

(57) **CLAIM**

The ornamental design for a vehicle grille, as shown and described in FIGS. 1-5.

DESCRIPTION

FIG. 1 is a front perspective view of a vehicle grille attached to a vehicle, no part of the vehicle is claimed;
FIG. 2 is a perspective view of the vehicle grille;
FIG. 3 is a front view of the vehicle grille;
FIG. 4 is a top view of the vehicle grille; and,
FIG. 5 is a left side view of the vehicle grille (the right side view is a mirror of the left side view and is not shown).
The broken lines shown throughout the drawing are for illustrative purposes only and form no part of the claimed design.

1 Claim, 5 Drawing Sheets

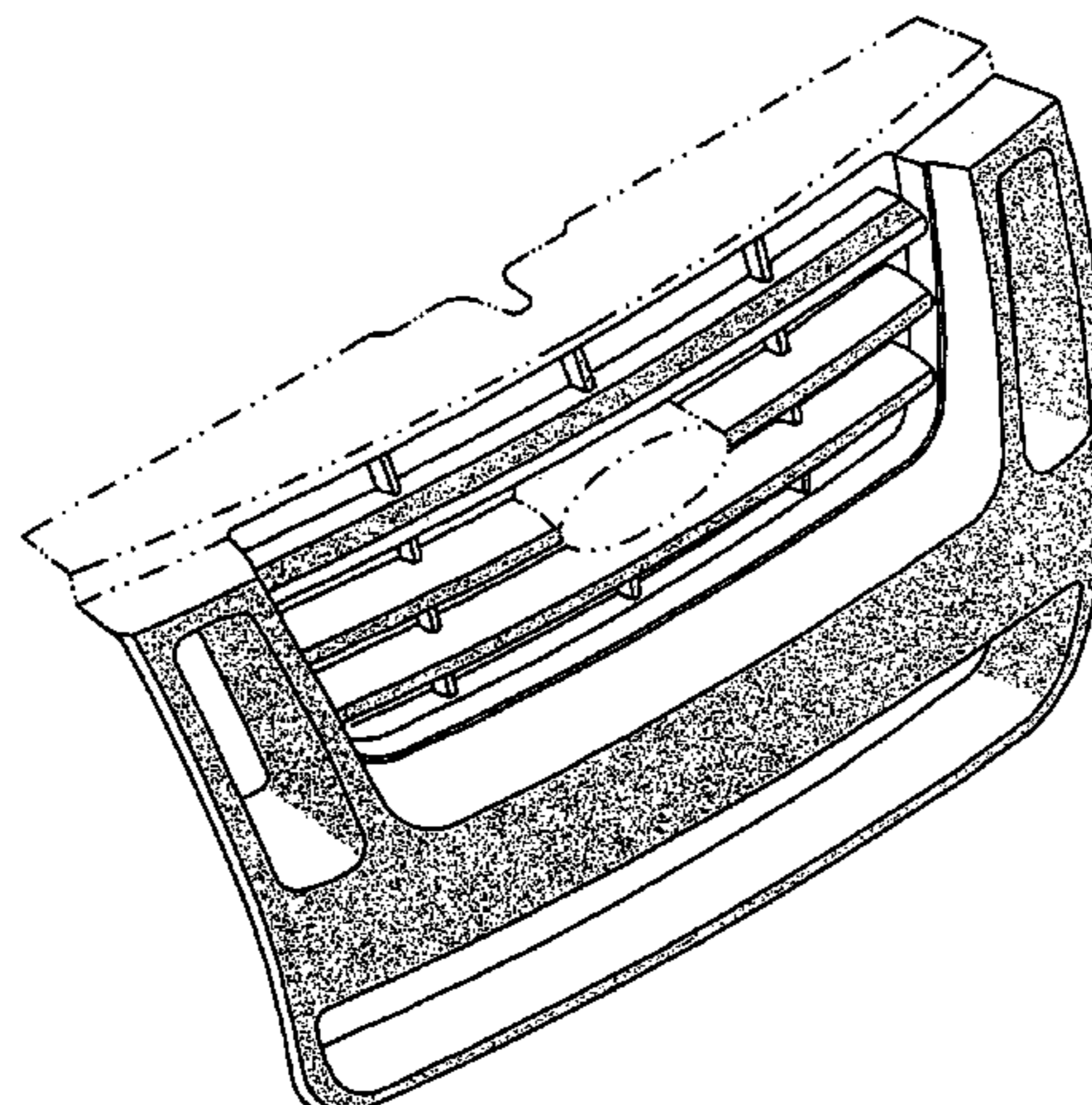

OTHER PUBLICATIONS

The Car Connection, *Spy Shots: '07 Explorer Sport Trac*, From concept to reality—really, really quickly. http://www.thecarconnection.com/Enthusiasts/Spy_shots/Spy_Shots_07_Explorer_Sport_Trac.S178.A8021.html, Jan. 24, 2005.

The Detroit News, Autos Insider: *Ford Sport Trac a preview of the new Explorer*, <http://info.detnews.com/autosinsider/sneakpeek/index.cfm?id=18254>, Feb. 2, 2005.

Automotive News, *Web watchers offer early read on autos*, v 79, No. 6140, p. 8, Mar. 28, 2005.

The Car Lounge, *2006 Ford Explorer*, <http://forums.thecarlounge.net/zerthread?id=1910776>, Mar. 30, 2005.

TheCarConnection.com, *Spy Shots: '06 Ford Explorer*, A sharper image of the perennial best-selling SUV. http://www.thecarconnection.com/Enthusiasts/Spy_Shots/Spy_Shots_06_Ford_Explorer.S178.A847.html, May 2, 2005.

Automotive News, *Exploring a new look*, p. 1, May 2, 2005.

Auto Week, *Exploring its Options: 2006 Ford Explorer gets new face and an optional Mustang V8*, <http://www.autoweek.com/article.cms?articleId=102311>, May 9, 2005.

TheCarConnection.com, *Future Cars: Ford/PAG/Mazda*, http://www.thecarconnection.com/Enthusiasts/Future_Cars/Ford.S283.A8367.html, May 16, 2005.

Motor Trend's Truck Trend, News Front: *Explorer Sport Trac*, p. 14, May/June 2005.

Motor Trend, *'06 Ford Explorer—Climbing Every Mountain*, p. 30, June 2005.

Popular Mechanics, *Detroit Spy Report*, p. 46, July 2005.

Edmunds.com, *2006 Ford Explorer Midsize SUV*, http://www.edmunds.com/future/2006/ford/explorer/100536557/preview.html?tid=edmunds.f.photos.leftsidenav..0.Ford*, date unknown.

Automobile Magazine Online, *2006 SUV Sneak Preview*, http://www.automobilemag.com/2006_sneak_preview/0503_sp_suv/, date unknown.

* cited by examiner

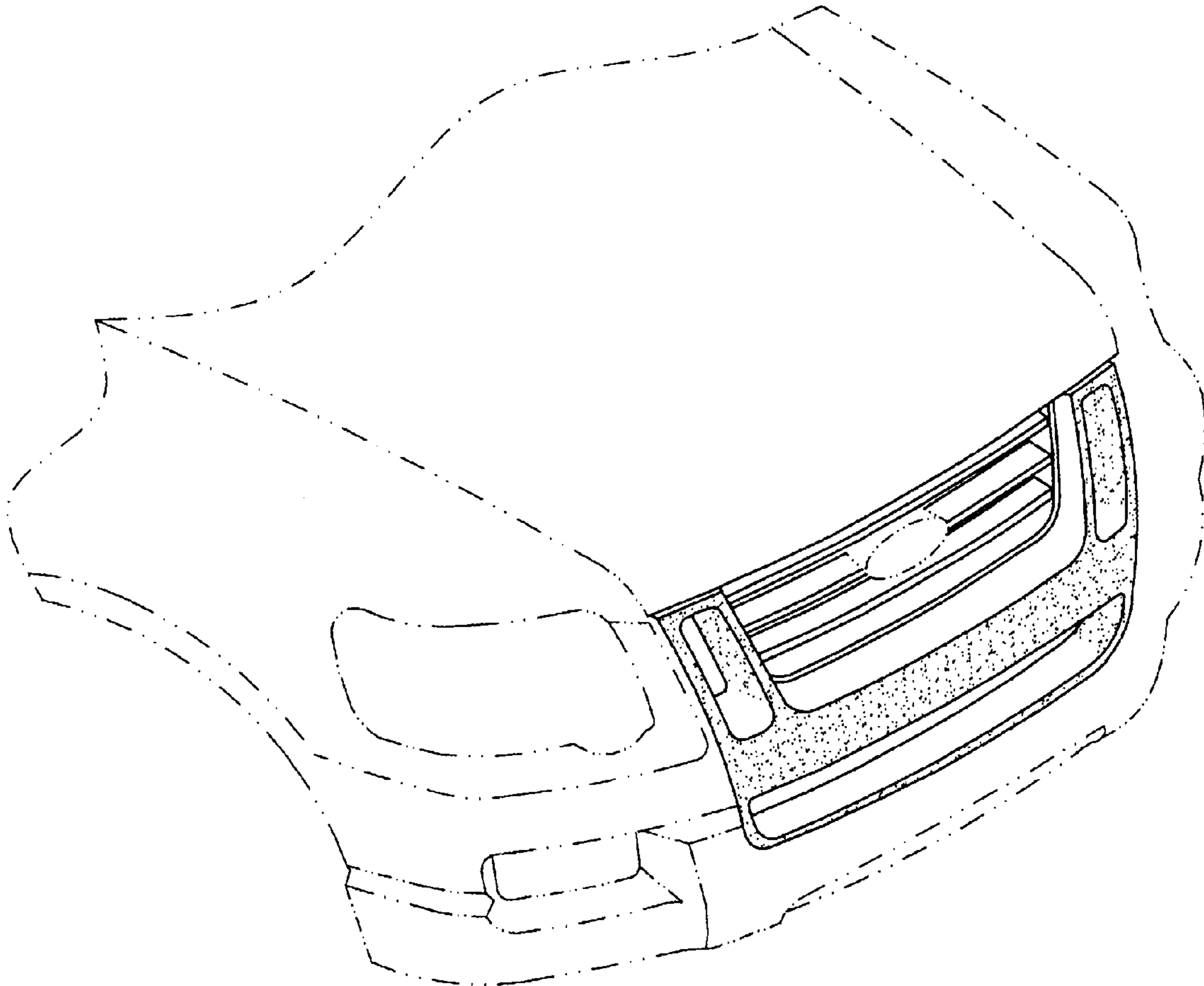

Figure 1

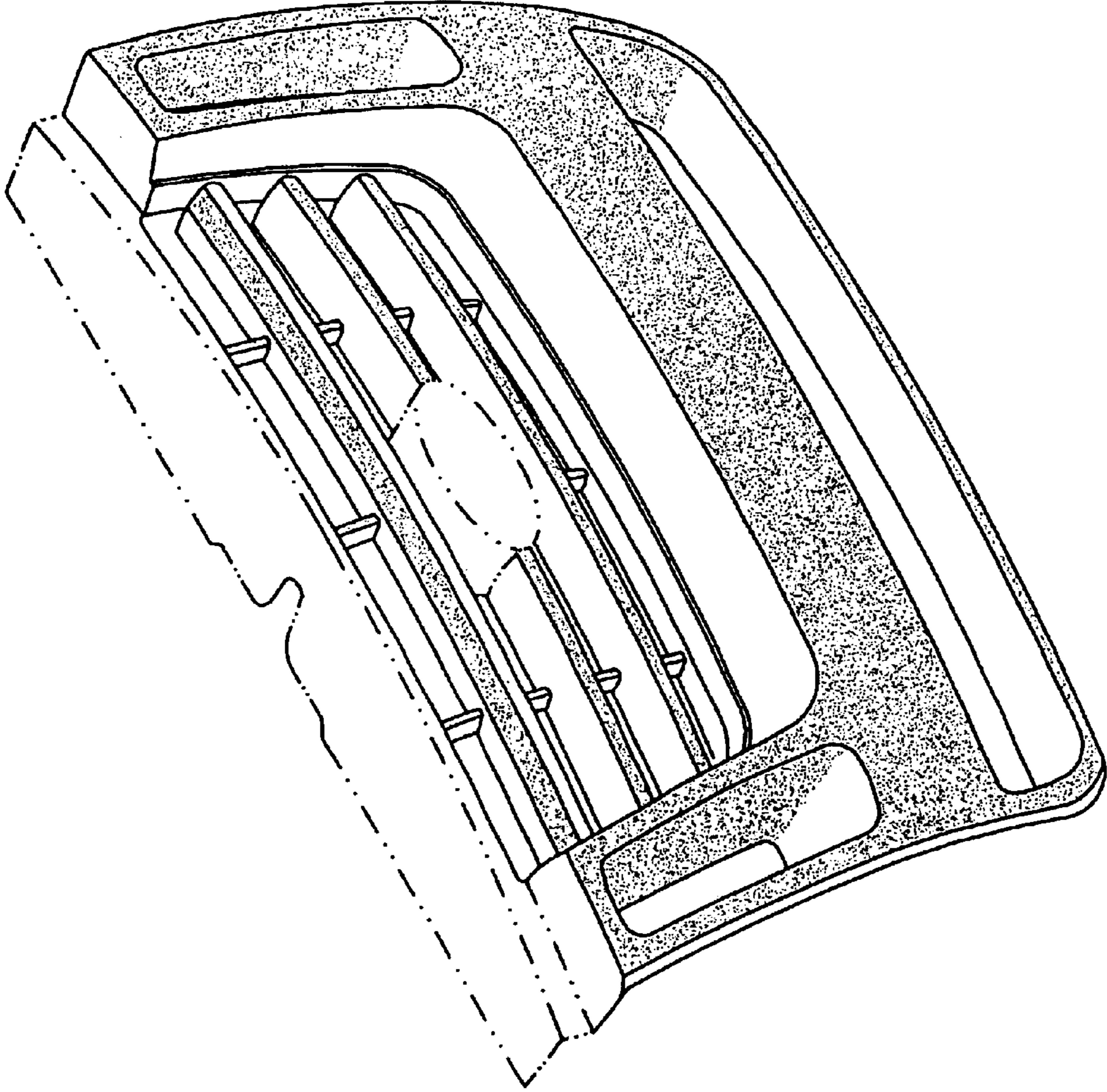

Figure 2

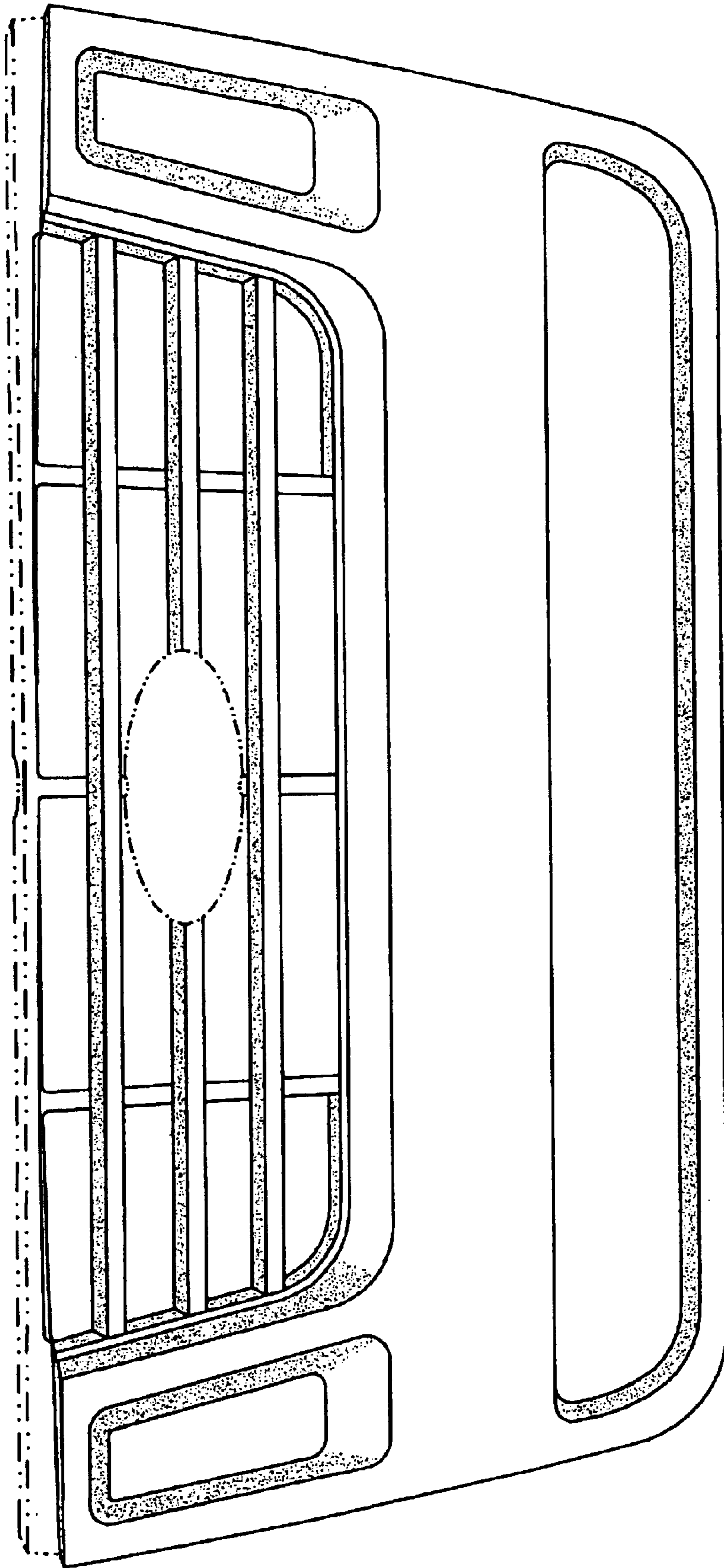

Figure 3

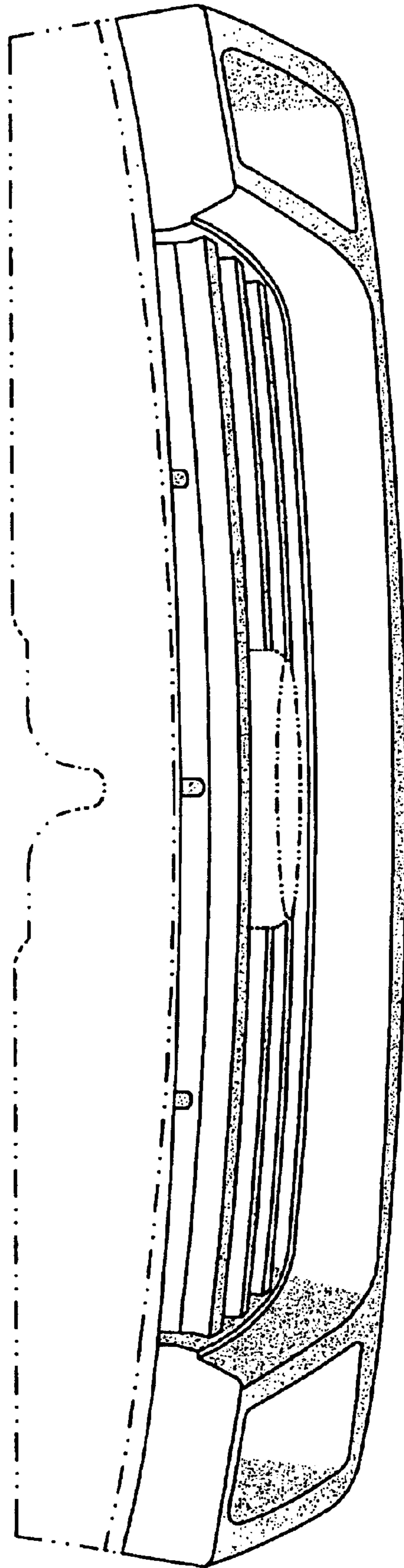

Figure 4

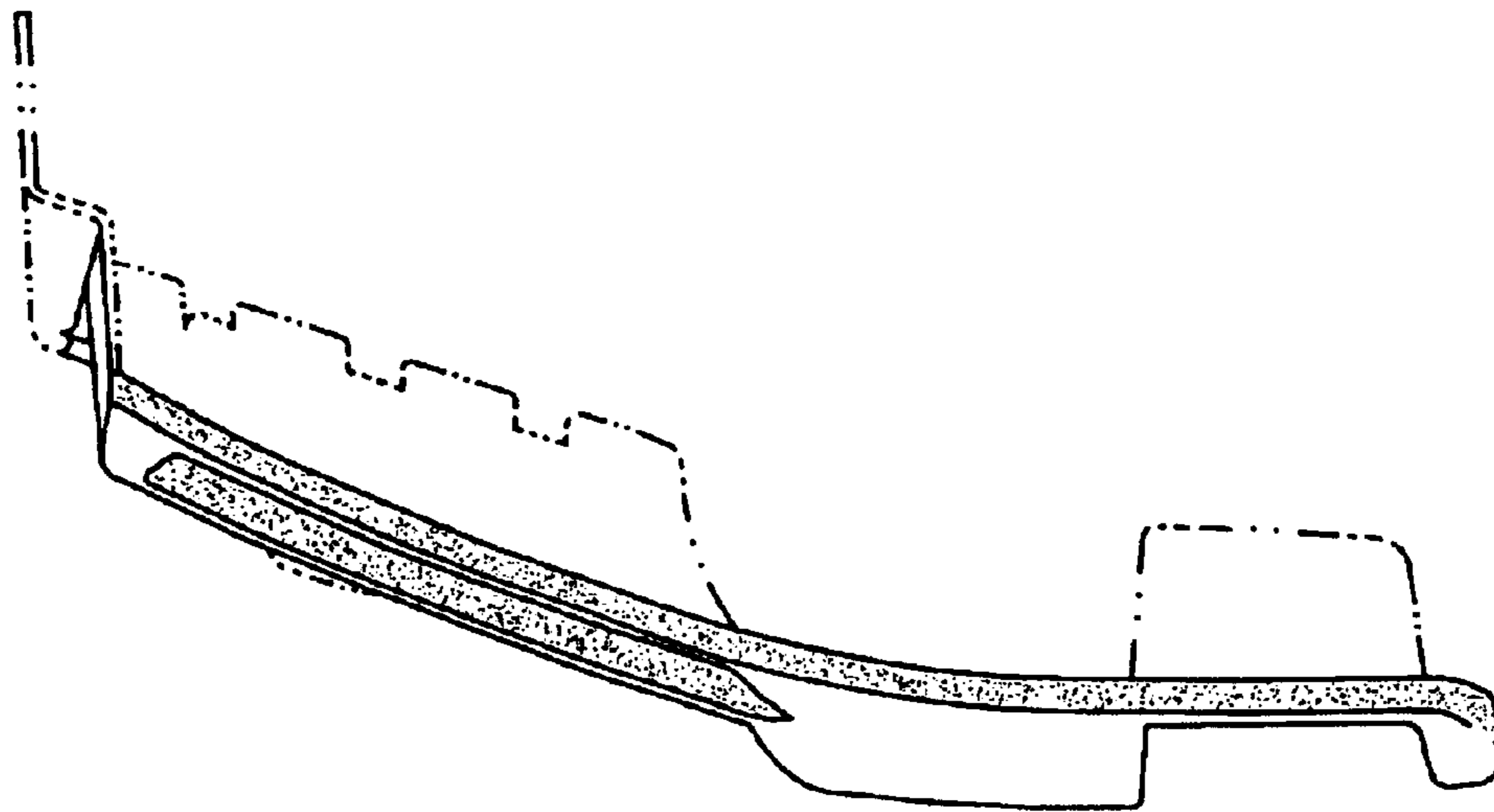

Figure 5