



US00D535580S

(12) **United States Design Patent**
Arbore

(10) **Patent No.:** **US D535,580 S**
(45) **Date of Patent:** **** Jan. 23, 2007**

- (54) **COMBINATION LOCK EARRING**
- (76) **Inventor:** **Mario Arbore**, 35-06 169th St., Suite A1, Flushing, NY (US) 11358
- (**) **Term:** **14 Years**
- (21) **Appl. No.:** **29/238,452**
- (22) **Filed:** **Sep. 15, 2005**

- D276,408 S * 11/1984 Zabel et al. D8/334
- D360,348 S * 7/1995 Kusmiss D8/334
- D392,206 S * 3/1998 Kothari D11/56
- D413,830 S * 9/1999 Moten D11/40

* cited by examiner

Primary Examiner—Louis S. Zarfaz

Assistant Examiner—Anhdao Doan

(74) *Attorney, Agent, or Firm*—Ostrolenk, Faber, Gerb & Soffen, LLP

Related U.S. Application Data

- (62) Division of application No. 29/203,930, filed on Apr. 20, 2004, now Pat. No. Des. 515,452.
- (51) **LOC (8) Cl.** **11-01**
- (52) **U.S. Cl.** **D11/48**
- (58) **Field of Classification Search** D11/40–44, D11/48, 60, 80, 81; D8/331, 333–335; 70/20, 70/21, 31; 63/1.11, 12, 13, 14.1, 18, 23
See application file for complete search history.

References Cited

U.S. PATENT DOCUMENTS

- D101,452 S * 10/1936 Fraim D8/334
- D144,685 S * 5/1946 Bouhall D8/334
- D179,085 S * 10/1956 Junkune D8/334
- D205,005 S * 6/1966 Harrell D8/334

(57) **CLAIM**

The ornamental design for a combination lock earring, as shown and described.

DESCRIPTION

FIG. 1 is a front elevation view of the present invention; FIG. 2 is a top plan view thereof; FIG. 3 is a bottom plan view thereof; FIG. 4 is a left side elevational view thereof; FIG. 5 is a right side elevational view thereof; FIG. 6 is a rear elevational view thereof; and, FIG. 7 is another front elevation view of the present invention with a lock in an open position. The broken line showing in FIG. 7 is for illustrative purposes only and forms no part of the claimed design.

1 Claim, 1 Drawing Sheet

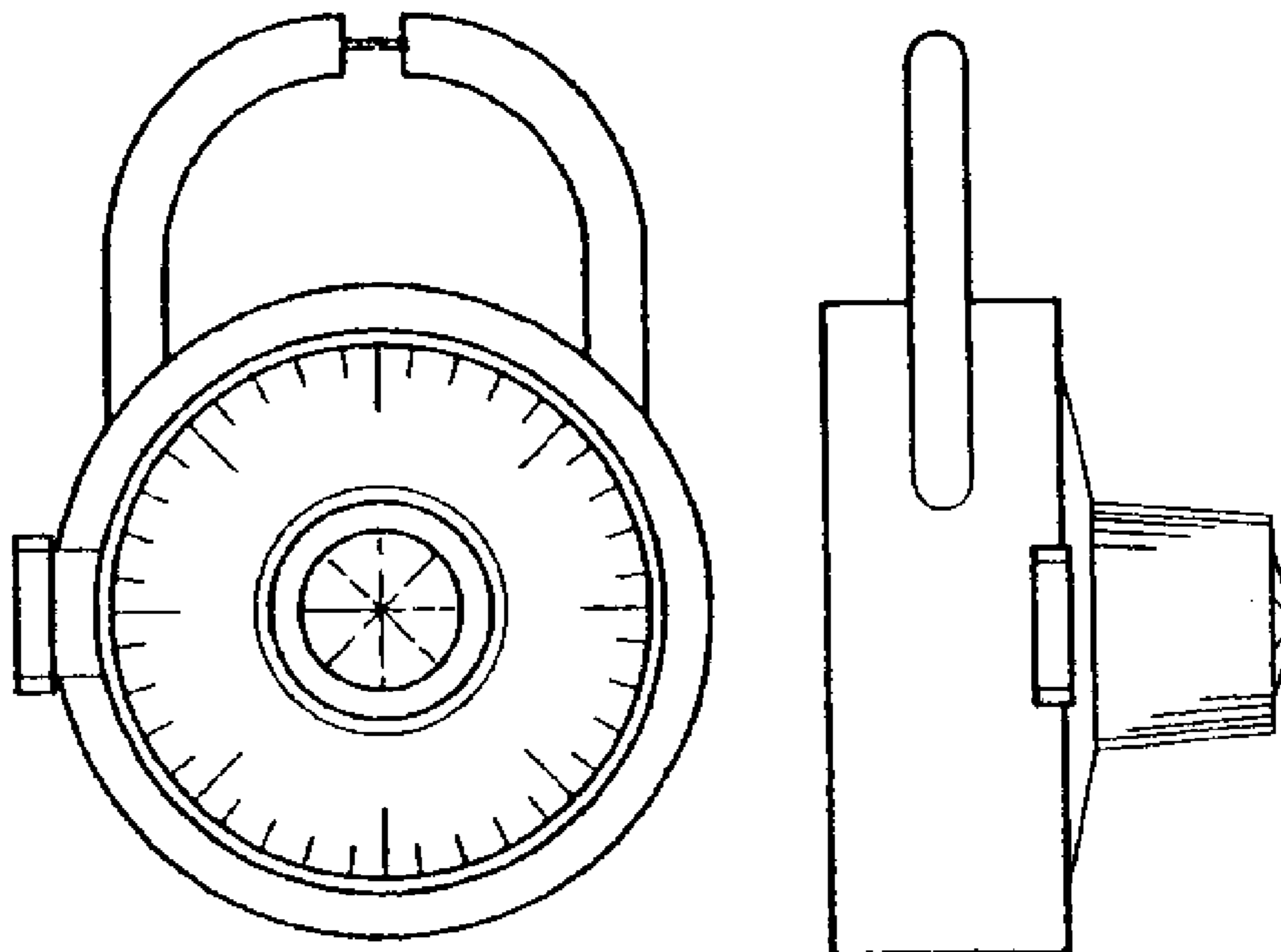

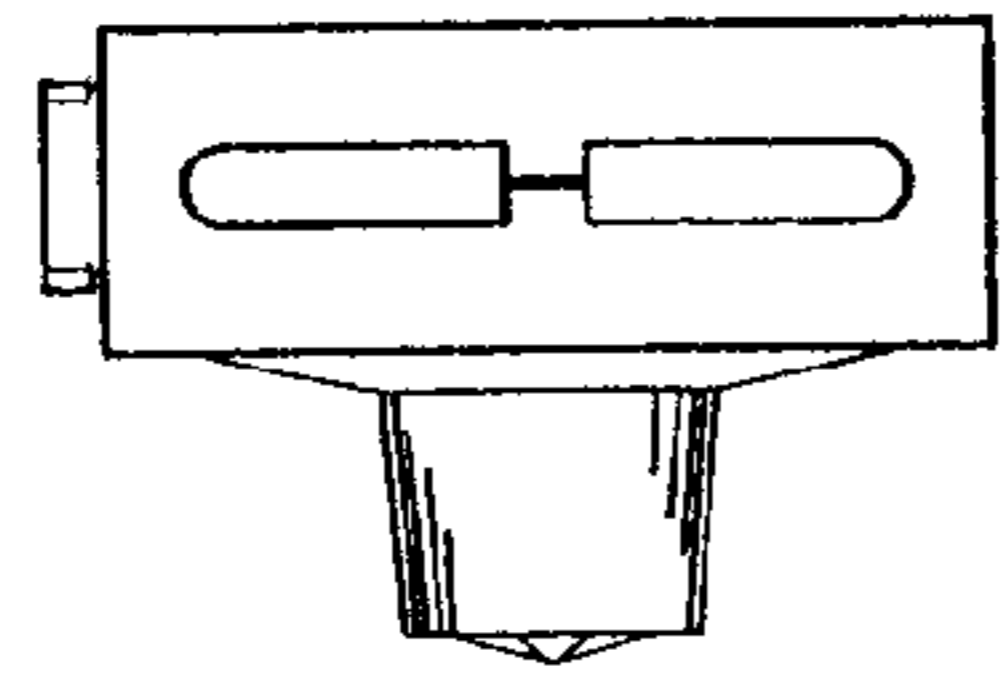

Figure 2

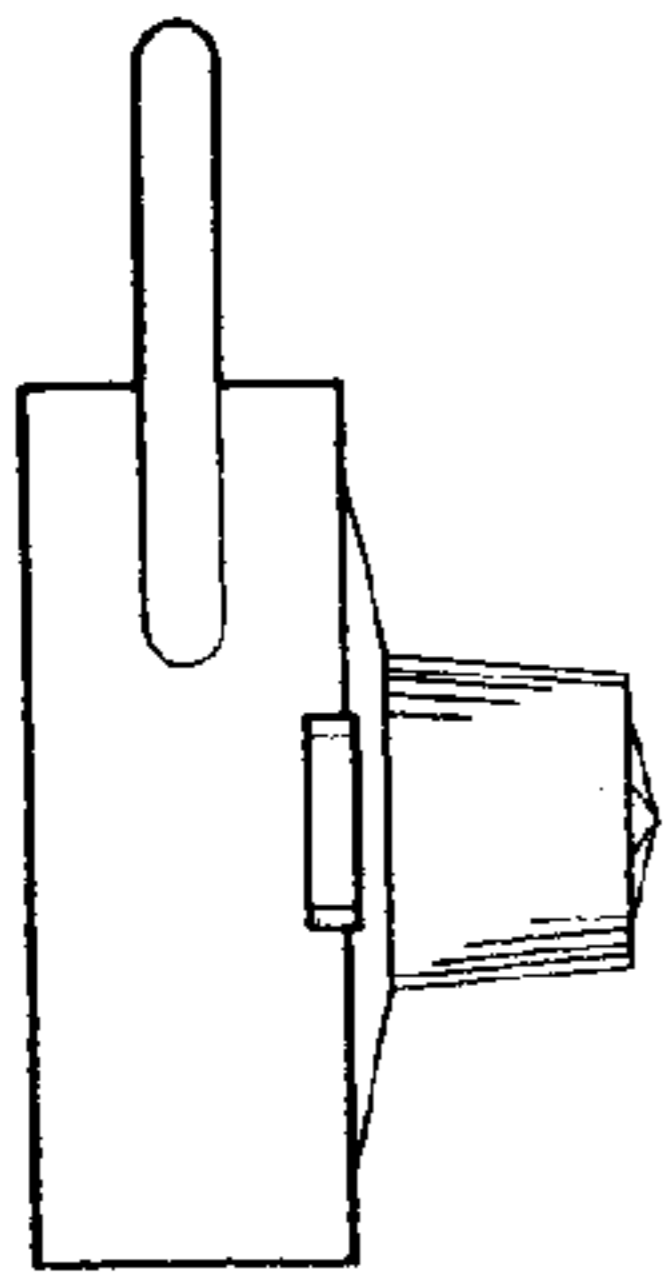

Figure 4

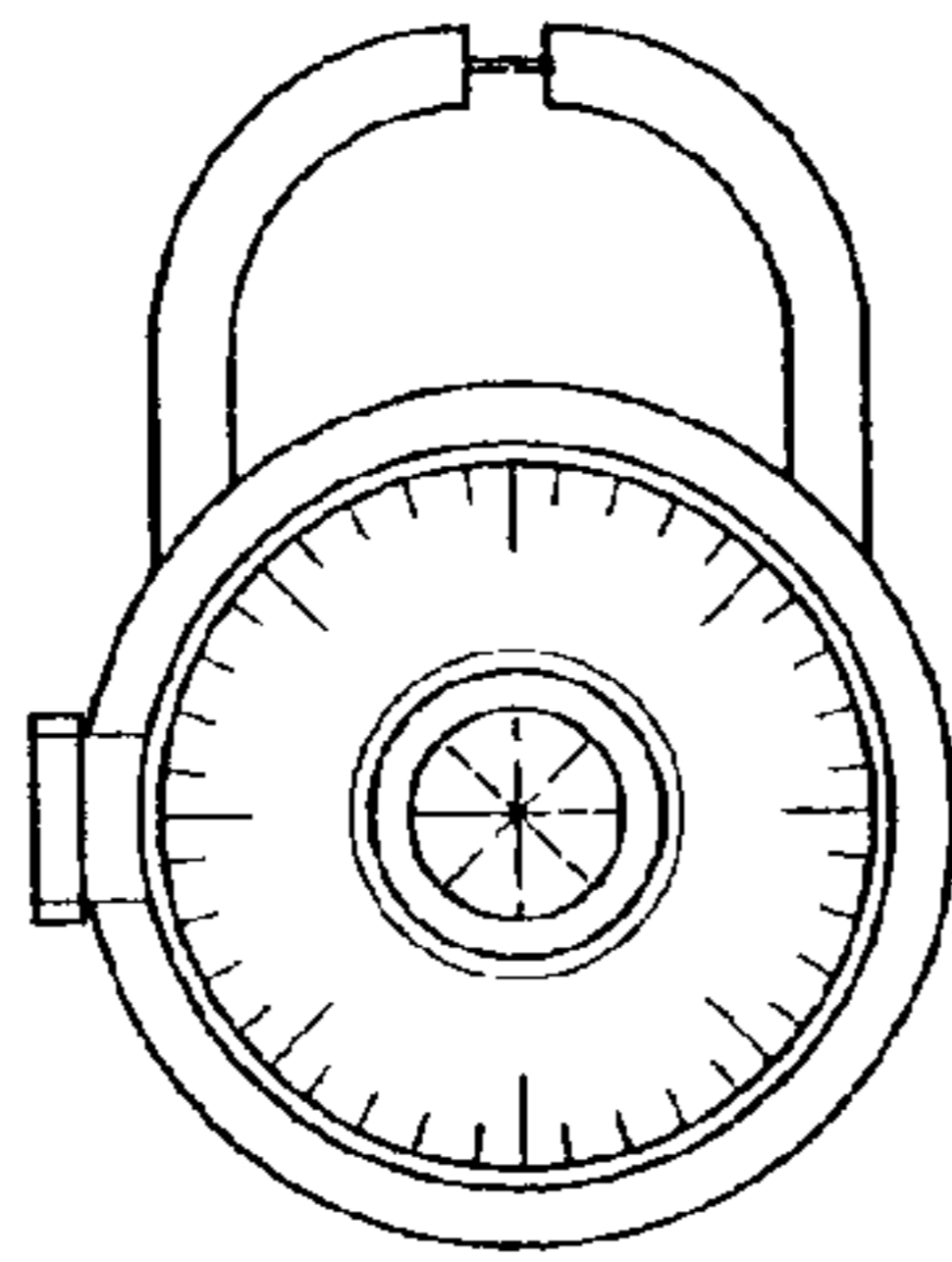

Figure 1

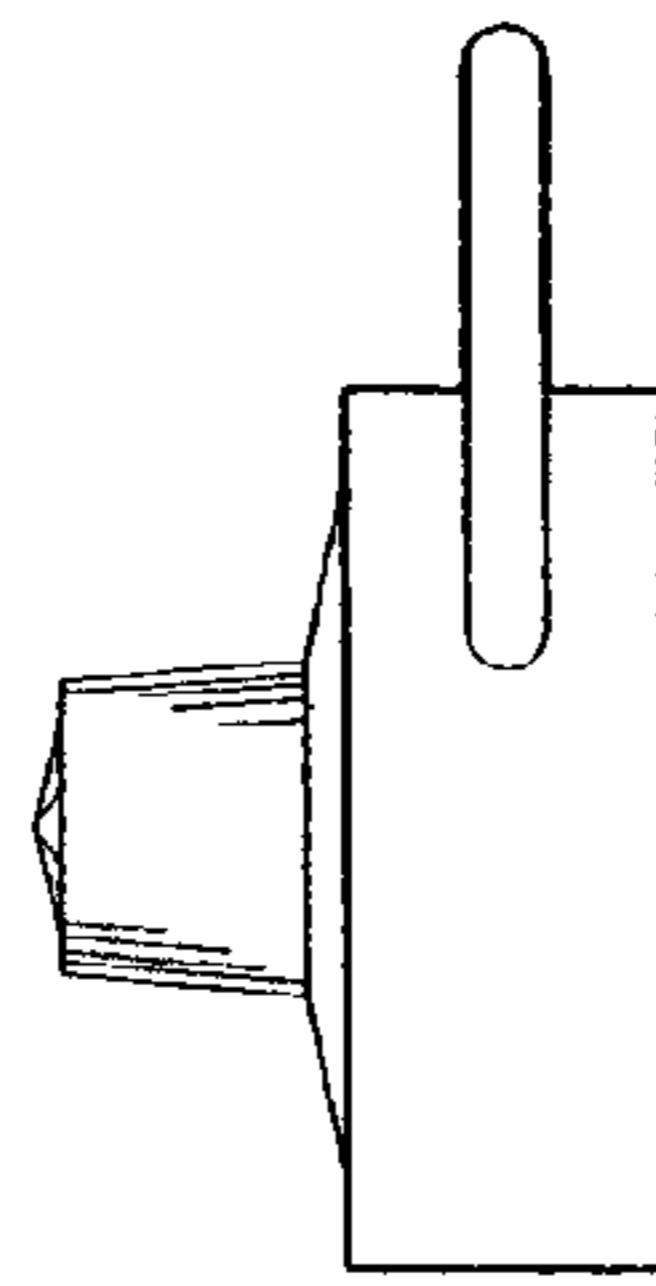

Figure 5

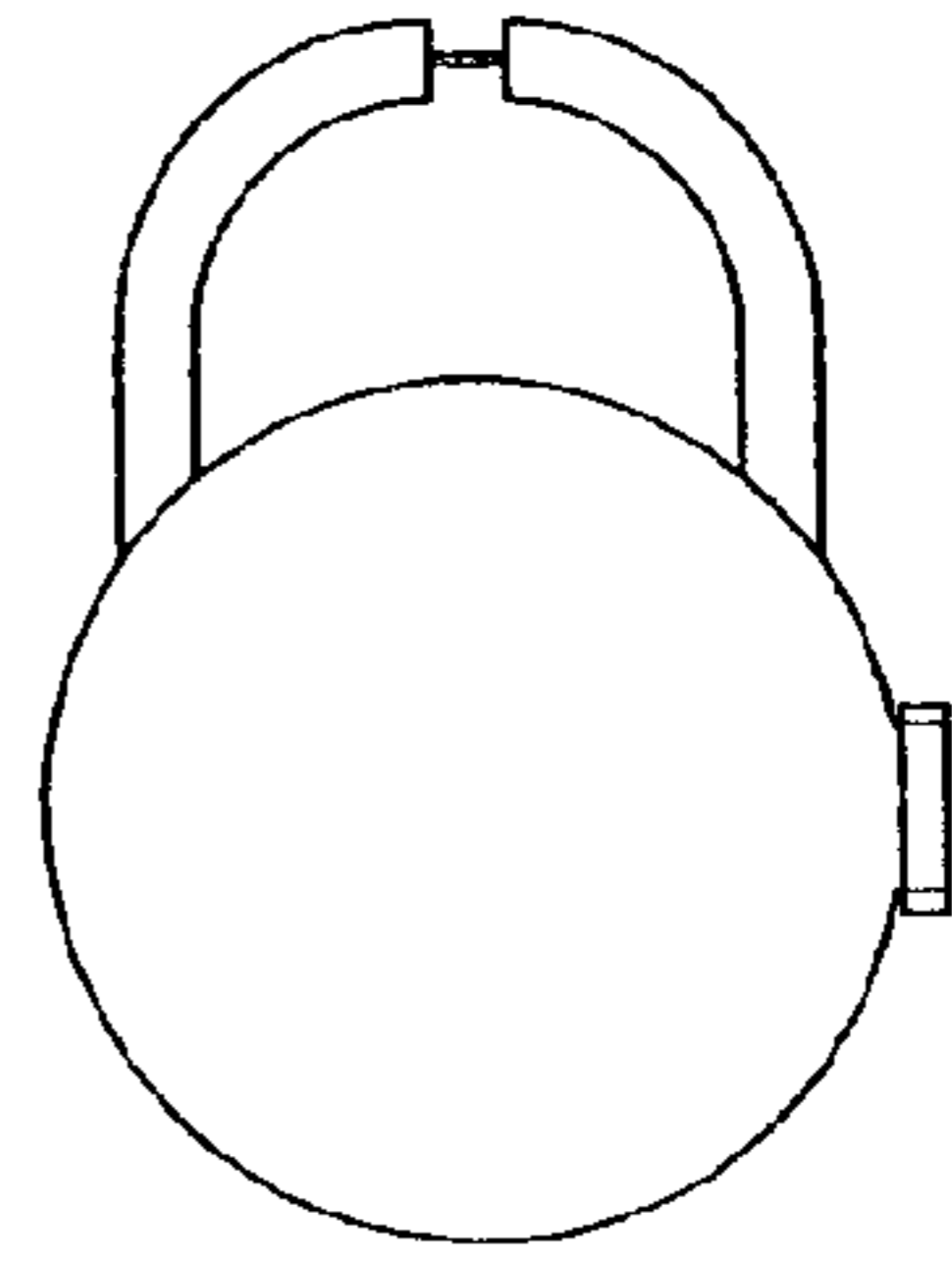

Figure 6

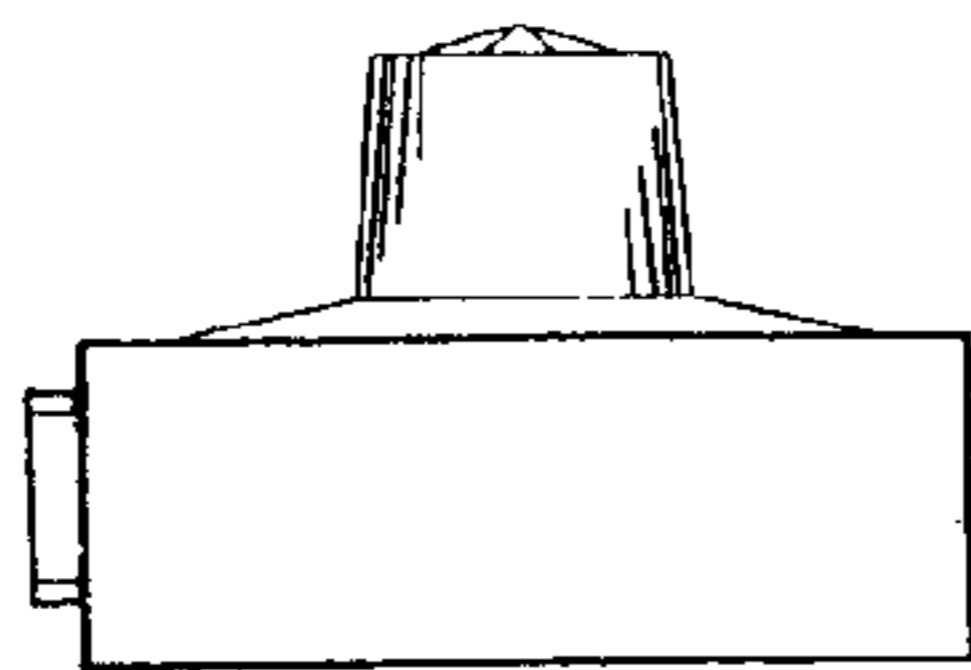

Figure 3

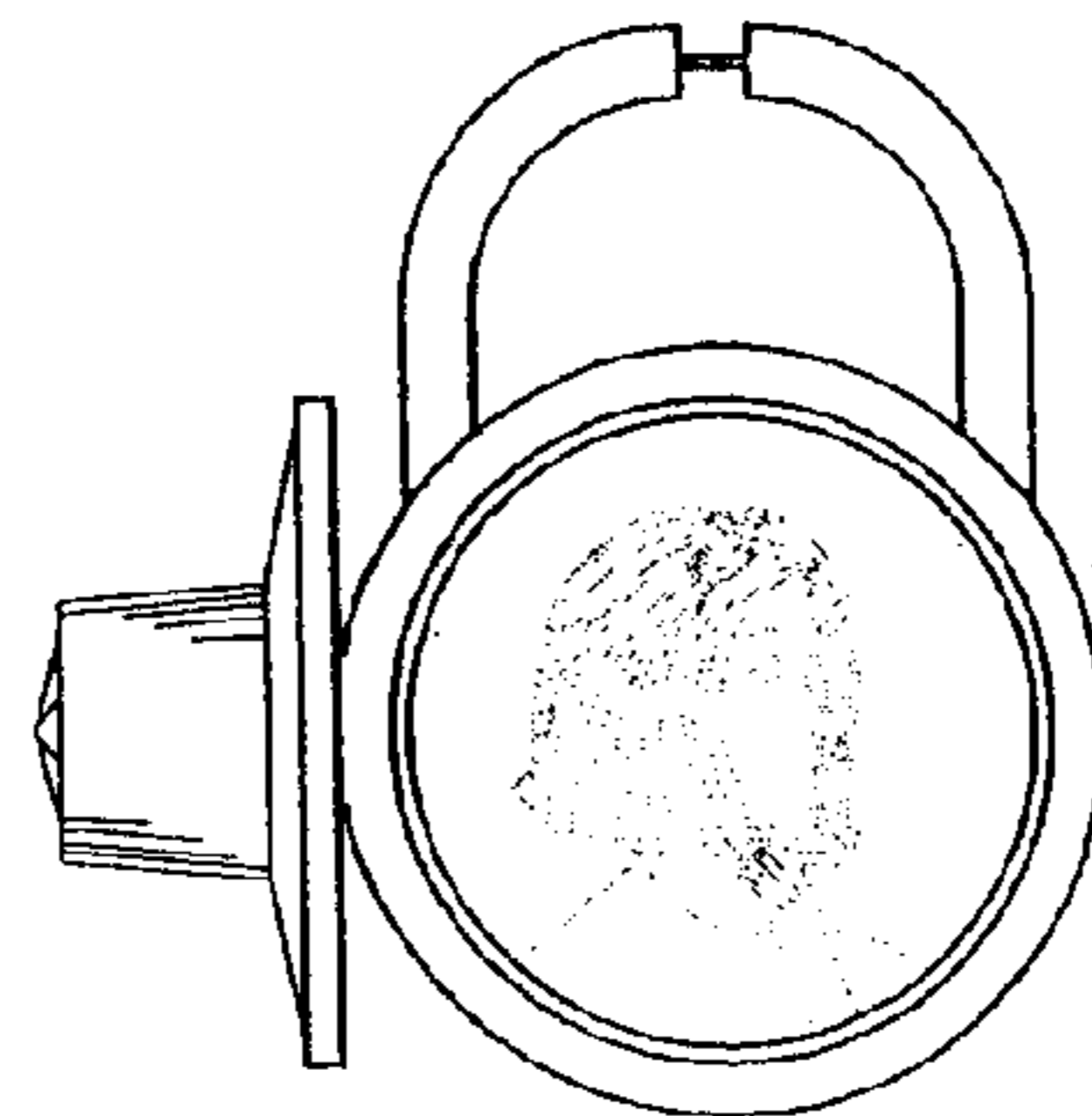

Figure 7