



US00D535232S

(12) **United States Design Patent**  
**Miyata et al.**

(10) **Patent No.:** **US D535,232 S**  
(45) **Date of Patent:** **\*\* Jan. 16, 2007**

(54) **REAR BUMPER FOR AN AUTOMOBILE**

(75) Inventors: **Shin Miyata**, Aichi-ken (JP); **Nicholas Hogios**, Port Melbourne (AU)  
(73) Assignee: **Toyota Jidosha Kabushiki Kaisha** (JP)  
(\*\*) Term: **14 Years**

(21) Appl. No.: **29/245,767**  
(22) Filed: **Dec. 28, 2005**

(51) **LOC (8) Cl.** ..... **12-16**  
(52) **U.S. Cl.** ..... **D12/169**  
(58) **Field of Classification Search** ..... D12/90-92,  
D12/86, 169, 196; 296/180.1, 180.2; 293/102,  
293/113, 115, 117, 120  
See application file for complete search history.

(56) **References Cited**

**U.S. PATENT DOCUMENTS**

D509,171 S \* 9/2005 Pfeiffer ..... D12/169  
D511,725 S \* 11/2005 Nagashima ..... D12/169  
D512,003 S \* 11/2005 Koide ..... D12/169

**OTHER PUBLICATIONS**

Honda, **LEGEND**, Brochure of **LEGEND**, Oct. 2004, Honda Motor Co., Ltd.  
Toyota, **COROLLA**, Brochure of **COROLLA**, Aug. 23, 2004, Toyota Jidosha Kabushiki Kaisha.  
\* cited by examiner

*Primary Examiner*—Melody N. Brown  
(74) *Attorney, Agent, or Firm*—SAIDMAN DesignLaw Group

(57) **CLAIM**

The ornamental design for a rear bumper for an automobile, as shown and described.

**DESCRIPTION**

FIG. 1 is a front perspective view of a rear bumper for an automobile showing our new design;  
FIG. 2 is front view thereof;  
FIG. 3 is a top view thereof; and,  
FIG. 4 is right-side view thereof, the left-side view being a mirror image.

**1 Claim, 2 Drawing Sheets**

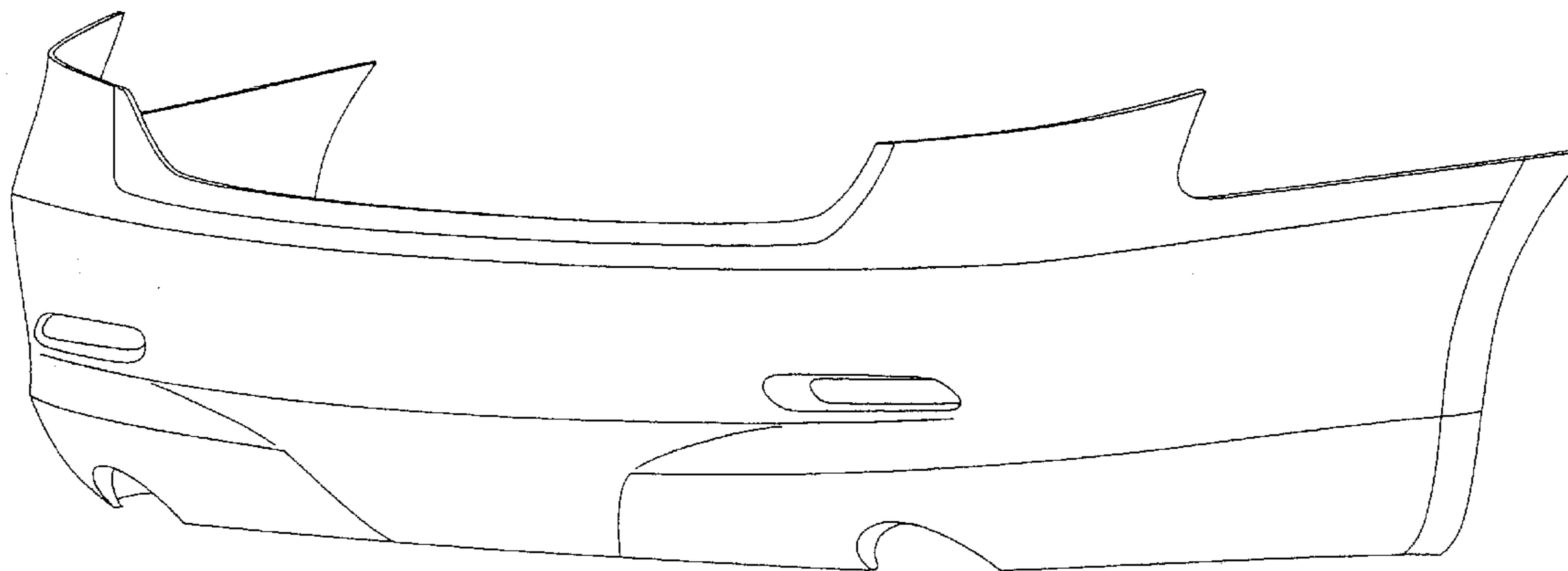

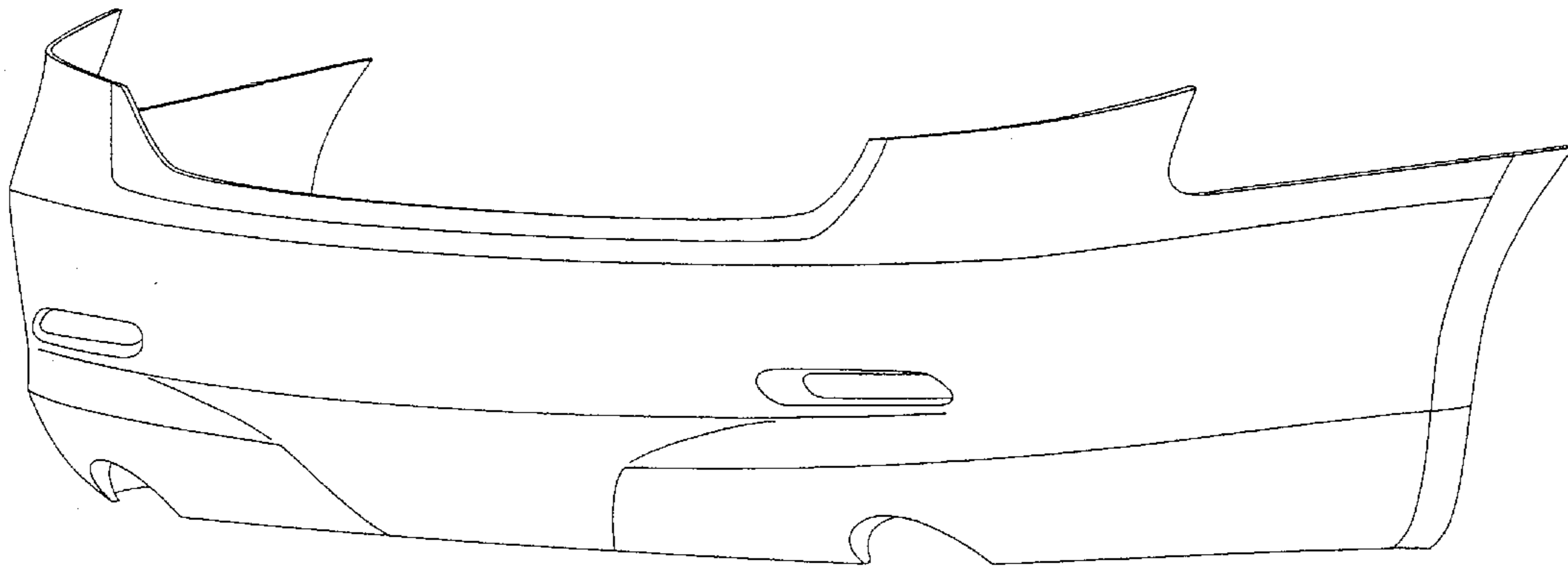

FIG. 1

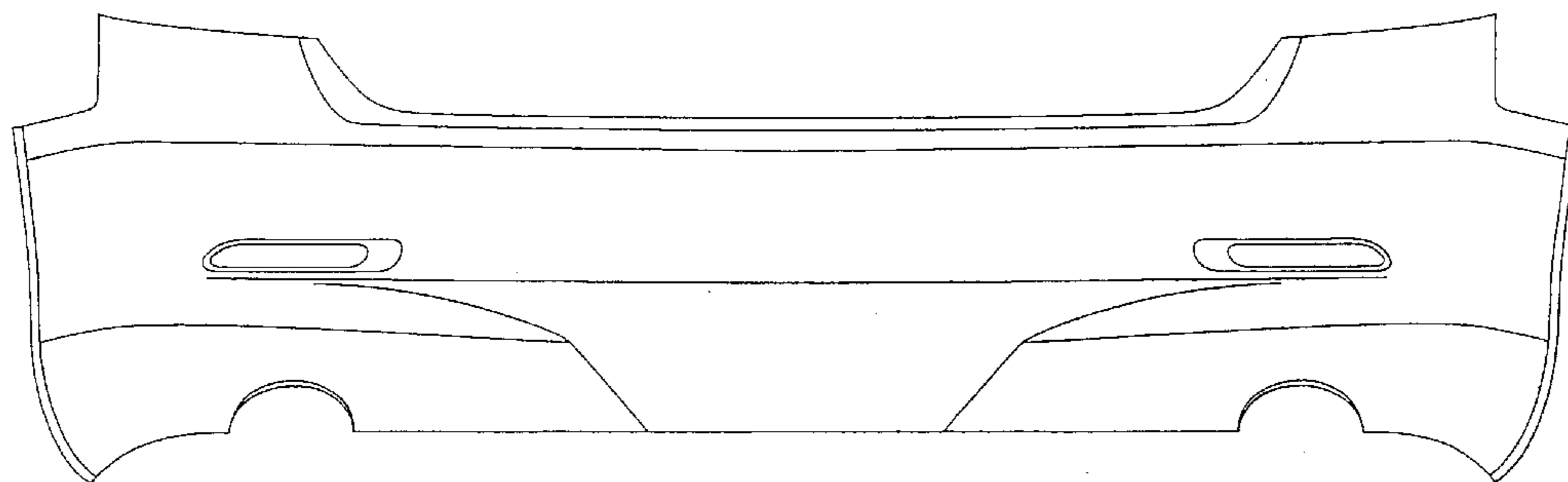

FIG. 2



FIG. 3

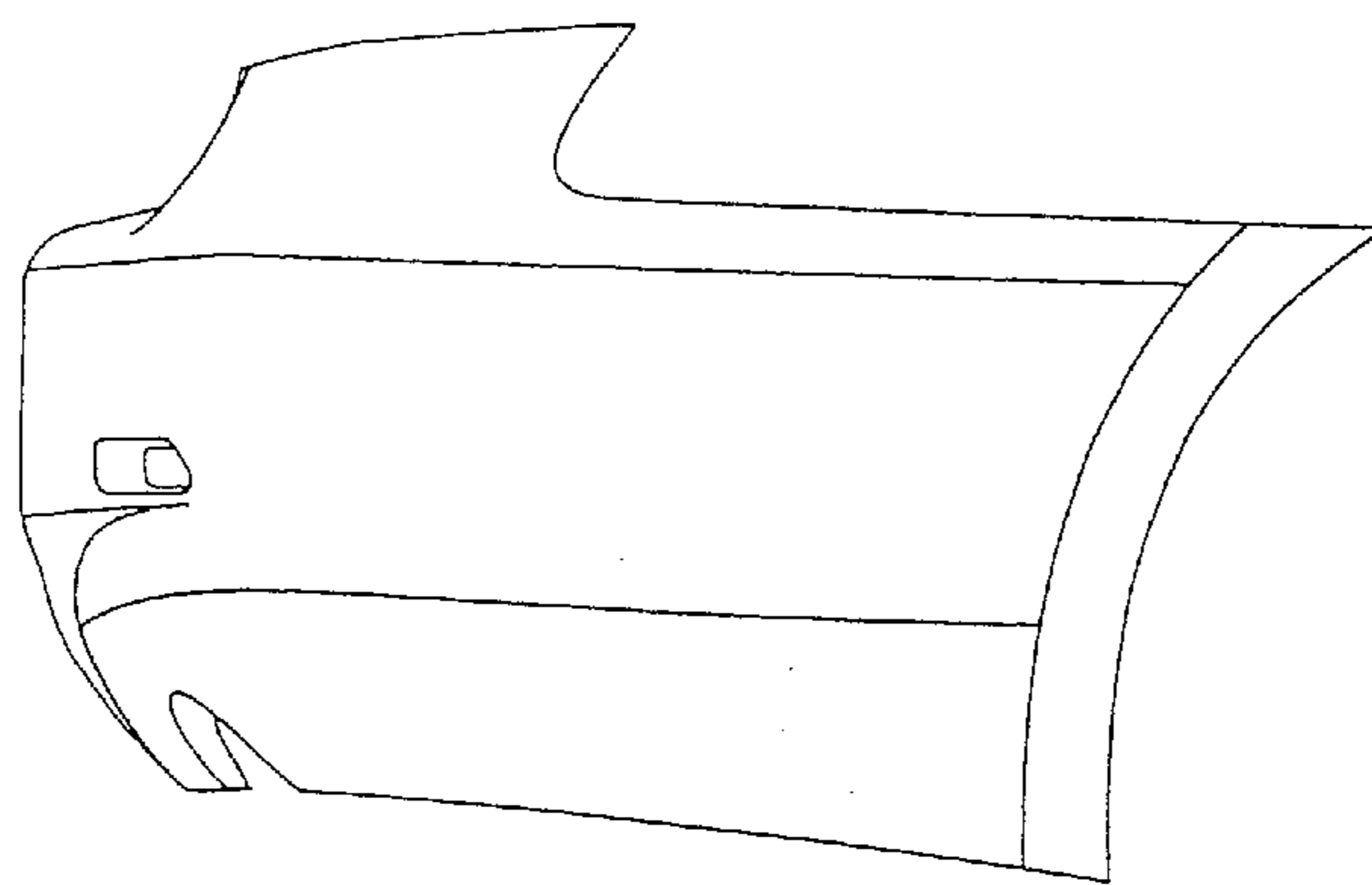

FIG. 4