



US00D535166S

(12) **United States Design Patent**
Kensrue et al.

(10) **Patent No.:** **US D535,166 S**
(45) **Date of Patent:** **** Jan. 16, 2007**

(54) **WELDING GUN**

3,898,419 A 8/1975 Smith
4,131,783 A 12/1978 Kensrue et al.

(75) Inventors: **Milo M. Kensrue**, Dana Point, CA (US); **Trung Dinh Nguyen**, Laguna Hills, CA (US)

(Continued)

FOREIGN PATENT DOCUMENTS

(73) Assignee: **M.K. Products, Inc.**, Irvine, CA (US)

EP 0042 311 A1 12/1981
WO WO 03/039800 A1 5/2003

(**) Term: **14 Years**

Primary Examiner—Philip S. Hyder

(21) Appl. No.: **29/226,900**

(74) *Attorney, Agent, or Firm*—Knobbe, Martens, Olson & Bear LLP

(22) Filed: **Apr. 4, 2005**

(57) **CLAIM**

(51) **LOC (8) Cl.** **08-05**

The ornamental design for a welding gun, as shown and described.

(52) **U.S. Cl.** **D8/30**

(58) **Field of Classification Search** D8/29.1,
D8/30; D15/144; 219/137.31, 137.62, 137.42;
266/48

DESCRIPTION

See application file for complete search history.

FIG. 1 is a perspective view of a welding gun showing our new design in accordance with a first embodiment of the invention;

(56) **References Cited**

U.S. PATENT DOCUMENTS

- 2,289,938 A 7/1942 Smith
- 2,315,358 A 3/1943 Smith
- 2,347,646 A 5/1944 Smith
- 2,379,470 A 7/1945 Baird
- 2,808,498 A 10/1957 Hudson et al.
- 3,088,642 A 5/1963 Kingsley
- 3,142,746 A 7/1964 Schmerling
- 3,165,662 A 1/1965 Norris
- 3,176,932 A 4/1965 Kovaleski
- 3,204,080 A 8/1965 Spencer
- 3,210,522 A 10/1965 Adamson et al.
- 3,227,852 A 1/1966 Fullerton et al.
- 3,305,664 A 2/1967 Kensrue
- D207,977 S 6/1967 Kensrue
- 3,334,841 A 8/1967 Burhop et al.
- 3,338,492 A 8/1967 Cornell et al.
- 3,344,305 A 9/1967 Ogden
- 3,428,778 A 2/1969 Blackman et al.
- 3,430,832 A 3/1969 Meyer
- 3,463,902 A 8/1969 Bircher
- 3,488,468 A 1/1970 Carbone
- 3,562,577 A 2/1971 Kensrue
- 3,744,694 A 7/1973 Karnes et al.

FIGS. 2–3 are side views thereof;

FIG. 4 is a top view thereof;

FIG. 5 is a bottom view thereof;

FIG. 6 is a front view thereof;

FIG. 7 is a rear view thereof;

FIG. 8 is a perspective view of a welding gun showing our new design in accordance with a second embodiment of the invention;

FIGS. 9–10 are side views of the welding gun as shown in FIG. 8;

FIG. 11 is a top view of the welding gun as shown in FIG. 8;

FIG. 12 is a bottom view of the welding gun as shown in FIG. 8;

FIG. 13 is a front view of the welding gun as shown in FIG. 8; and,

FIG. 14 is a rear view of the welding gun as shown in FIG. 8.

Phantom lining, where utilized, is for illustrative purposes only and does not limit or form any part of the claimed design.

1 Claim, 8 Drawing Sheets

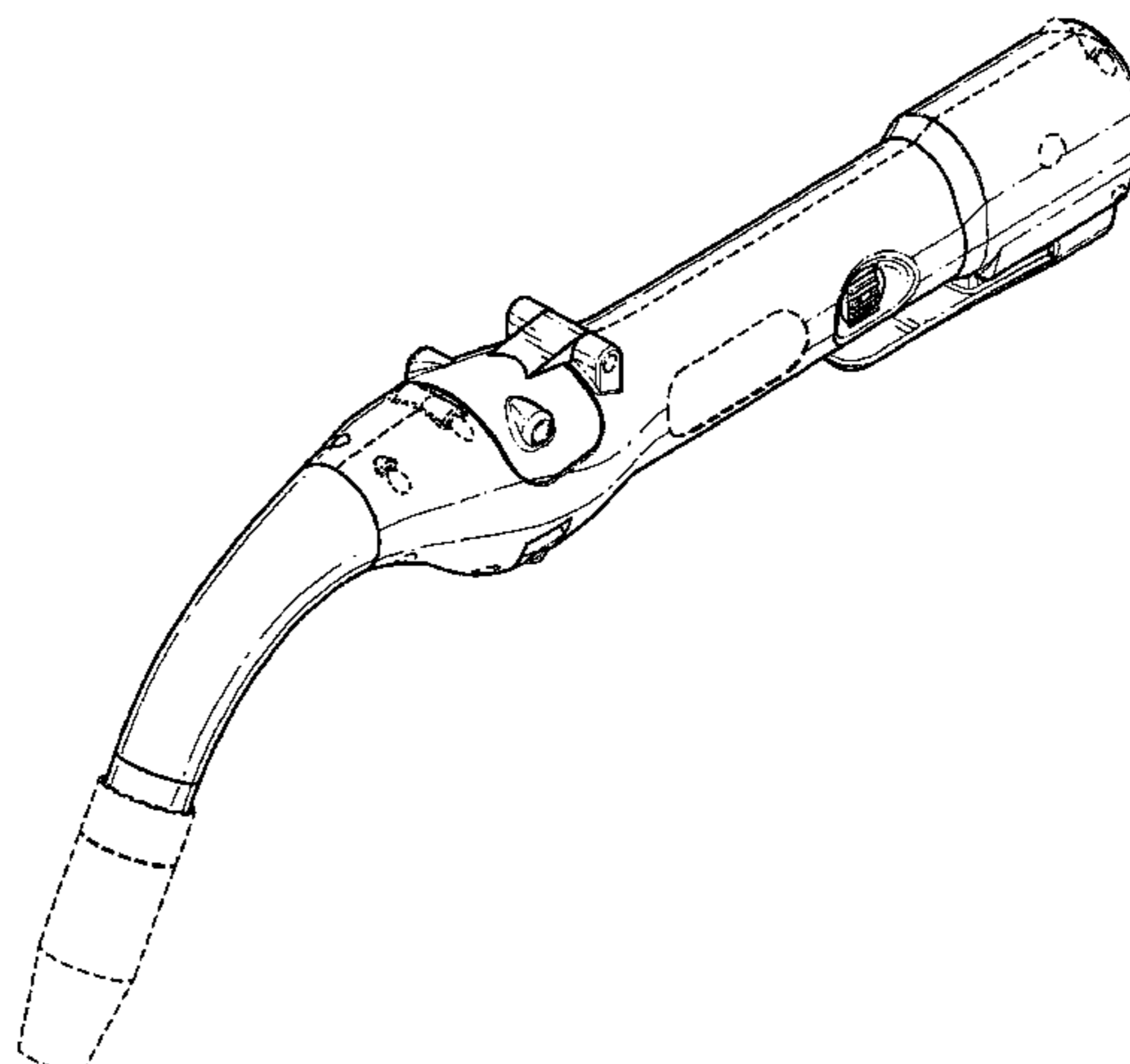

US D535,166 S

Page 2

U.S. PATENT DOCUMENTS

4,165,829 A	8/1979	Koveshnikov et al.	5,595,671 A	1/1997	David
4,206,862 A	6/1980	DaCosta	D382,500 S *	8/1997	Johnson et al. D10/96
D256,325 S	8/1980	Crooks et al.	5,728,995 A	3/1998	Kensrue
4,235,362 A	11/1980	Hubenko	5,738,264 A	4/1998	Jackson et al.
4,403,136 A	9/1983	Colman	5,782,394 A	7/1998	Langley
4,404,457 A	9/1983	Rokujio et al.	5,816,466 A	10/1998	Seufer
4,575,612 A	3/1986	Prunier	6,025,574 A *	2/2000	Colangelo, Jr. 219/137.31
4,617,447 A	10/1986	O'Donohue	6,064,036 A	5/2000	Kensrue
4,727,238 A	2/1988	Mann	RE36,997 E	12/2000	Kensrue
4,733,052 A	3/1988	Nilsson et al.	6,225,599 B1	5/2001	Altekruse
4,845,336 A	7/1989	Samokovliiski et al.	6,271,497 B1	8/2001	Zapletal
4,885,453 A	12/1989	Martin	D456,678 S	5/2002	Karten
4,954,690 A	9/1990	Kensrue	6,427,894 B1	8/2002	Blank et al.
5,132,513 A *	7/1992	Ingwersen et al. 219/137.31	6,559,416 B1	5/2003	Steenis et al.
D329,179 S	9/1992	Kensrue	6,568,578 B1	5/2003	Kensrue
D343,629 S *	1/1994	Bode D15/144	6,649,858 B1 *	11/2003	Wakeman 219/137.31
D346,390 S *	4/1994	Sperling et al. D15/144	6,710,300 B1	3/2004	Steenis et al.
5,326,958 A	7/1994	Geus	6,740,848 B1	5/2004	Parker
5,488,217 A	1/1996	Ni	6,824,735 B1 *	11/2004	Pryor 266/48
5,586,709 A	12/1996	Del Fabro et al.	2003/0209530 A1	11/2003	Stuart et al.

* cited by examiner

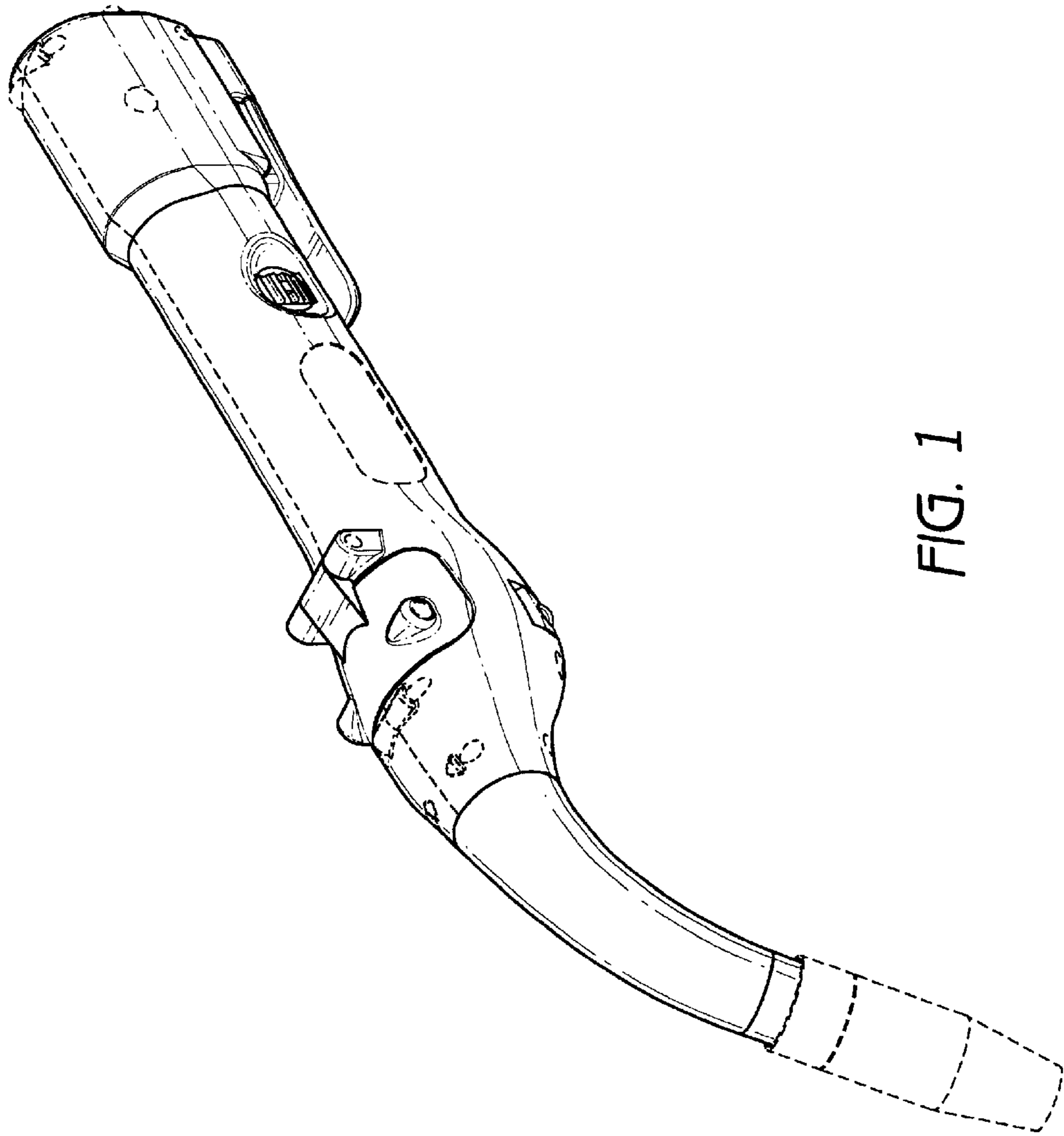
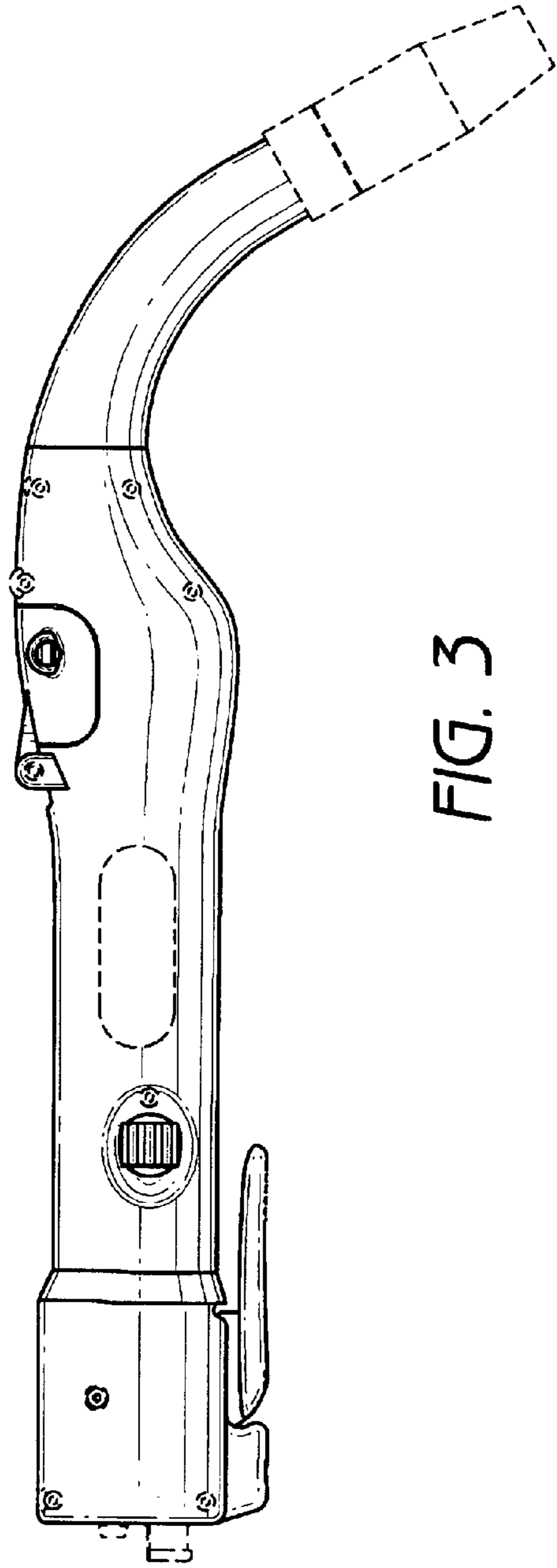
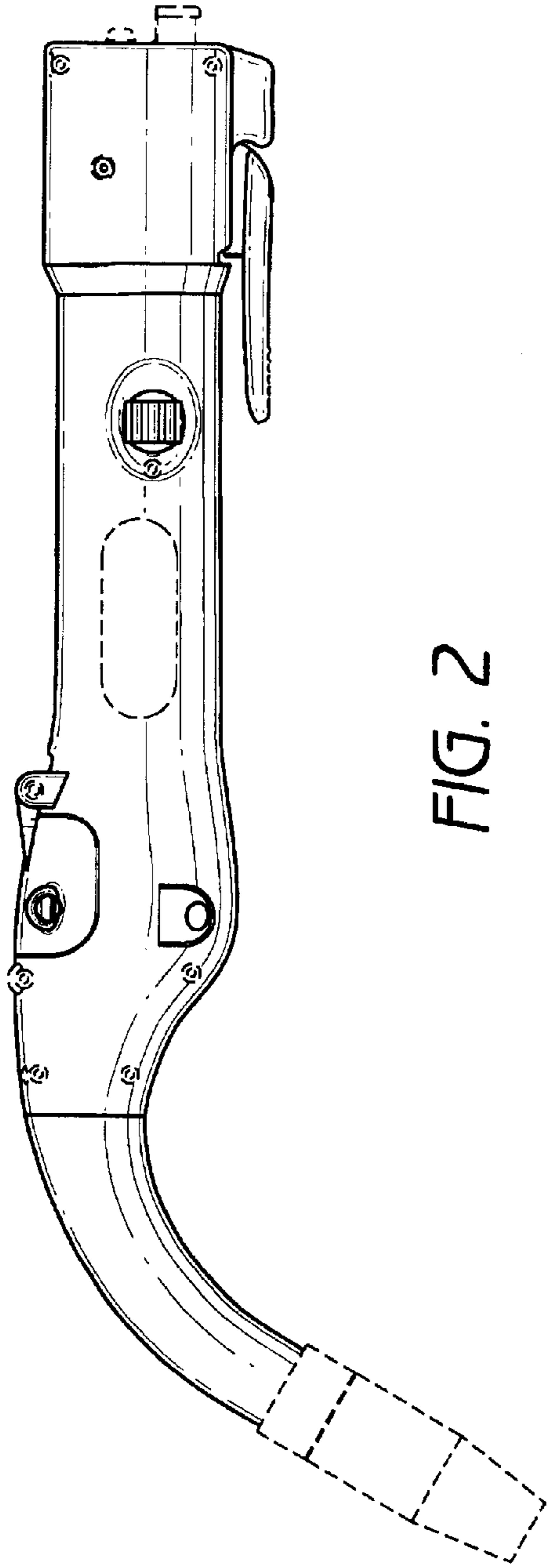

FIG. 1



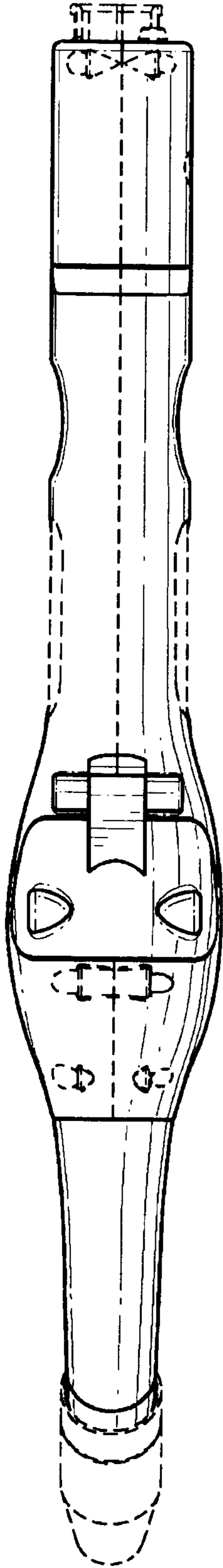

FIG. 4

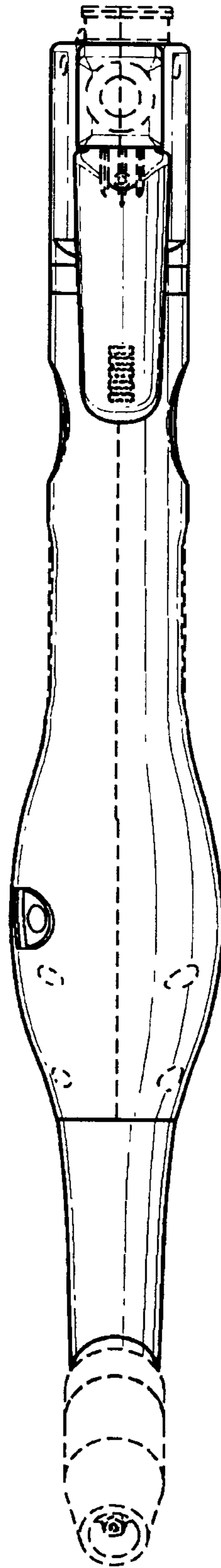

FIG. 5

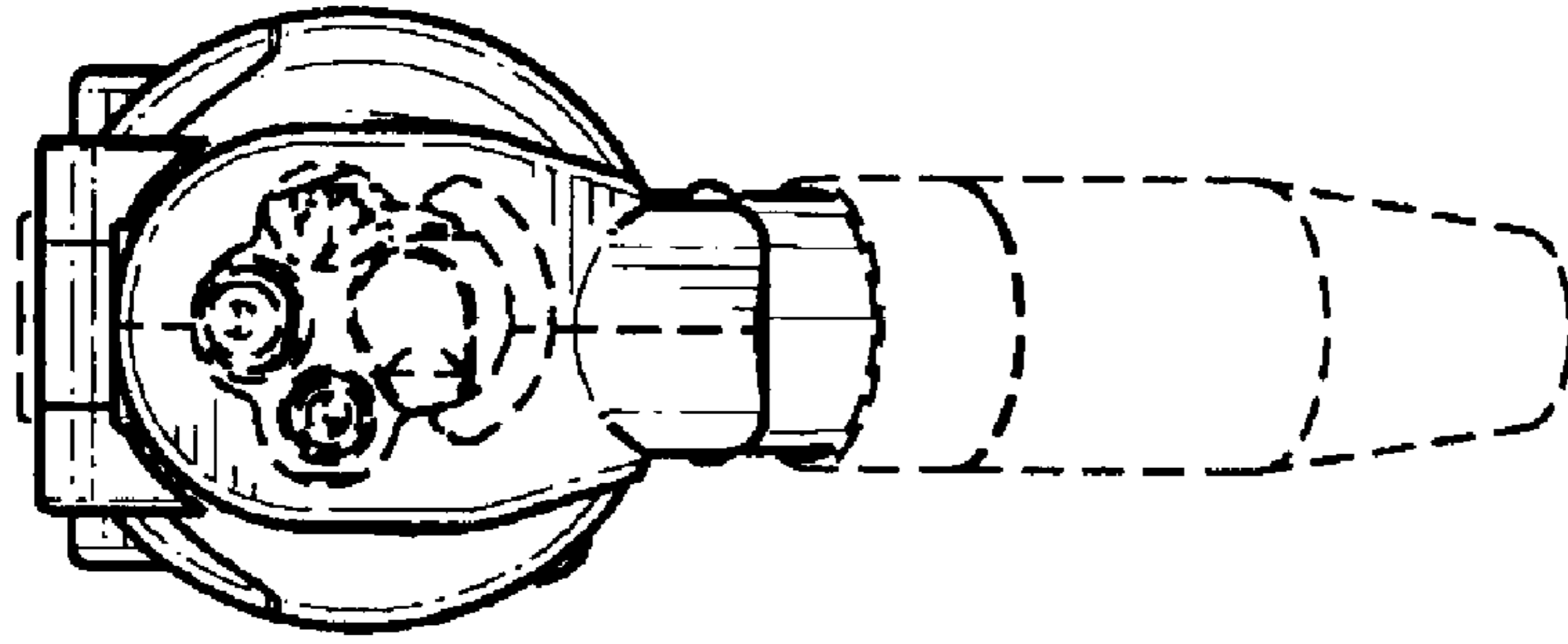

FIG. 6

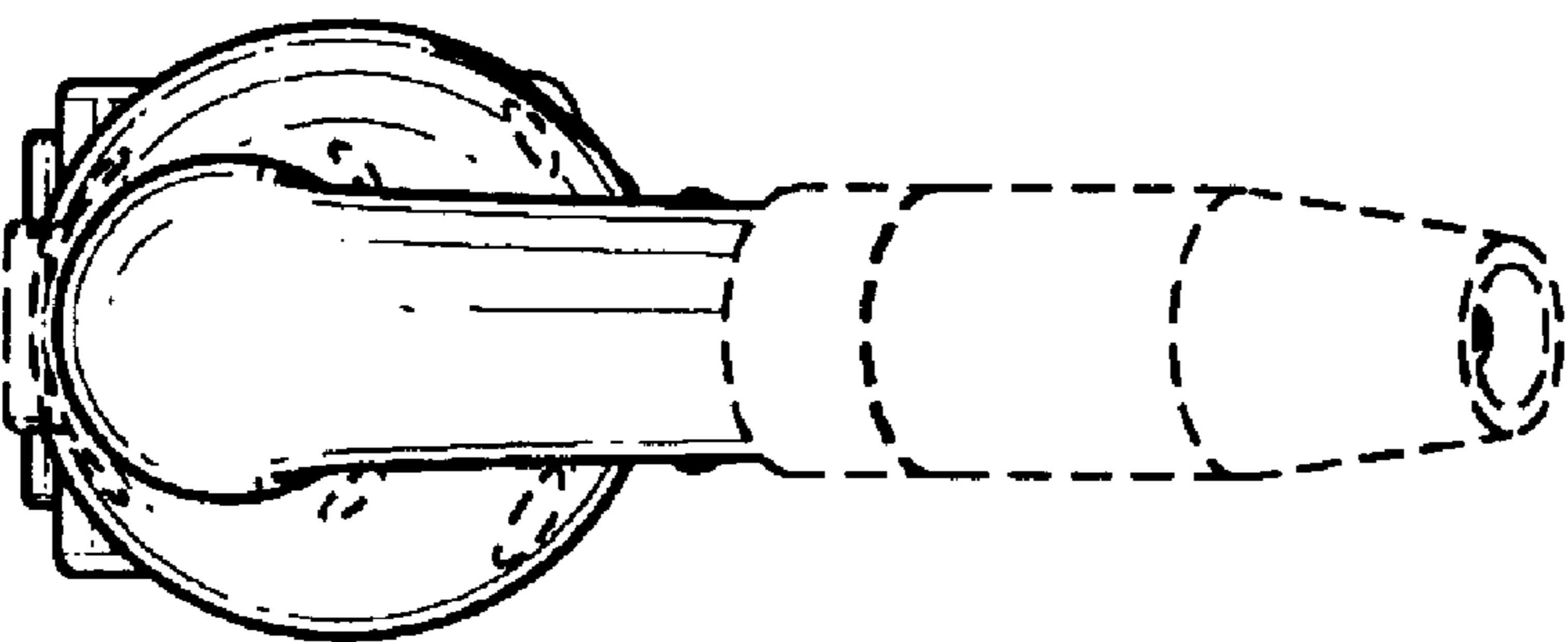

FIG. 7

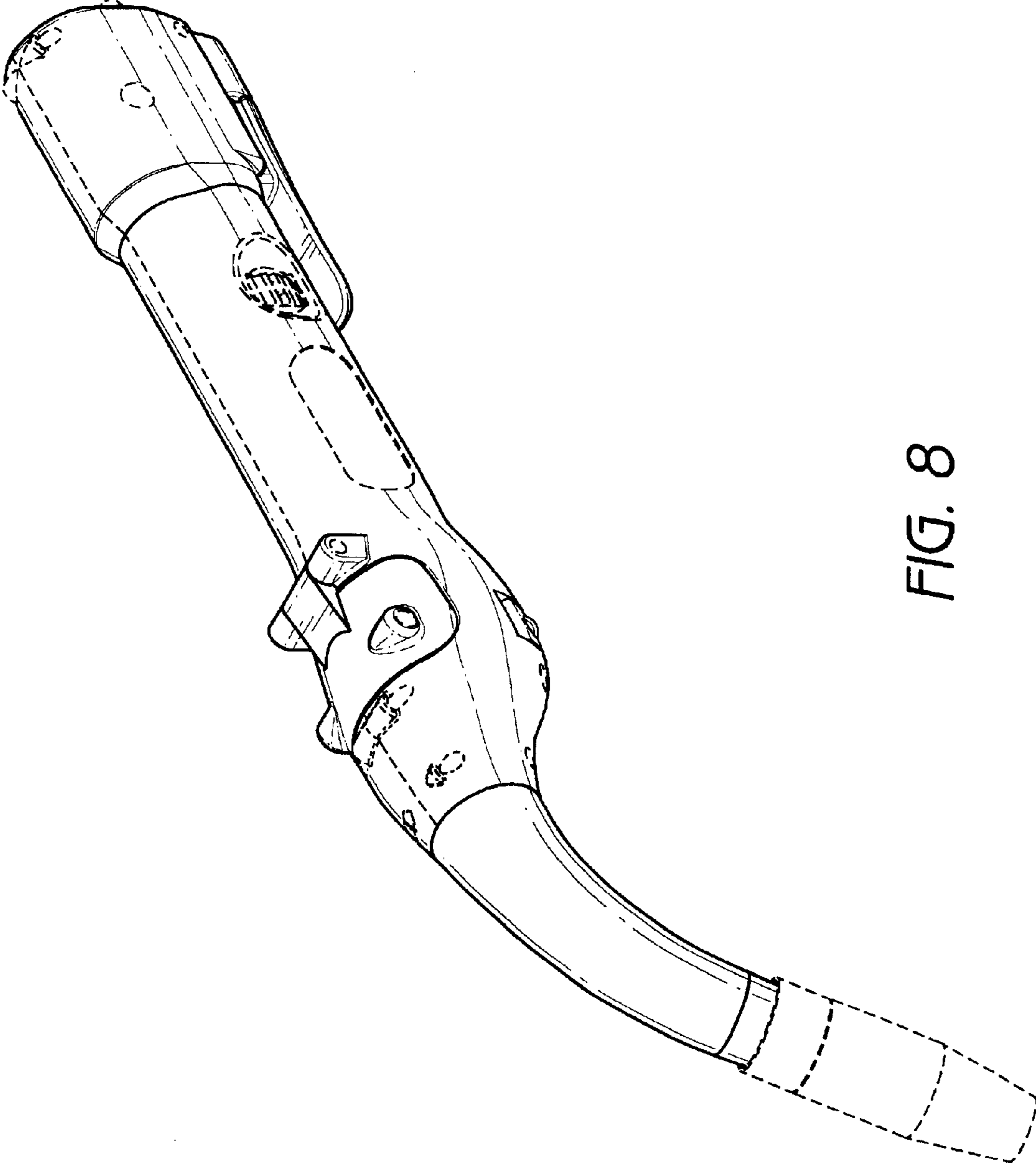

FIG. 8

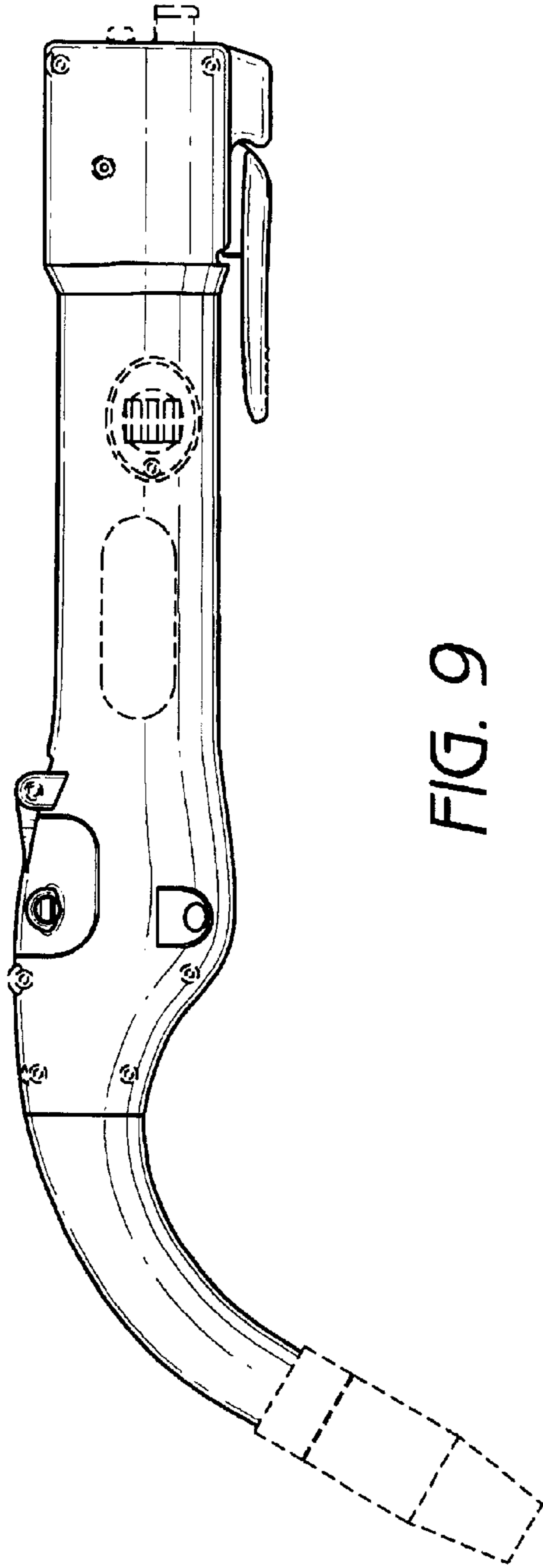

FIG. 9

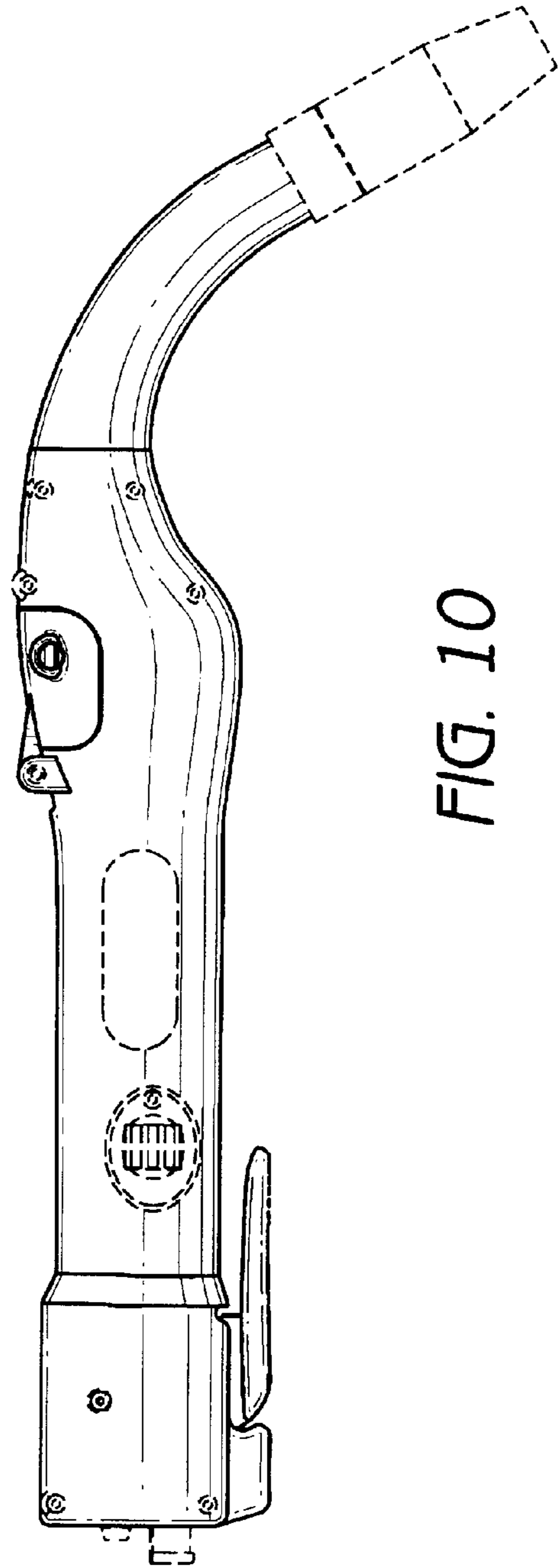

FIG. 10

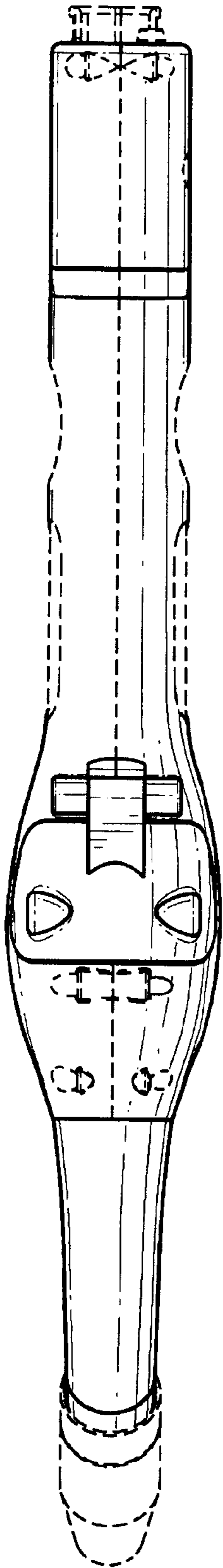

FIG. 11

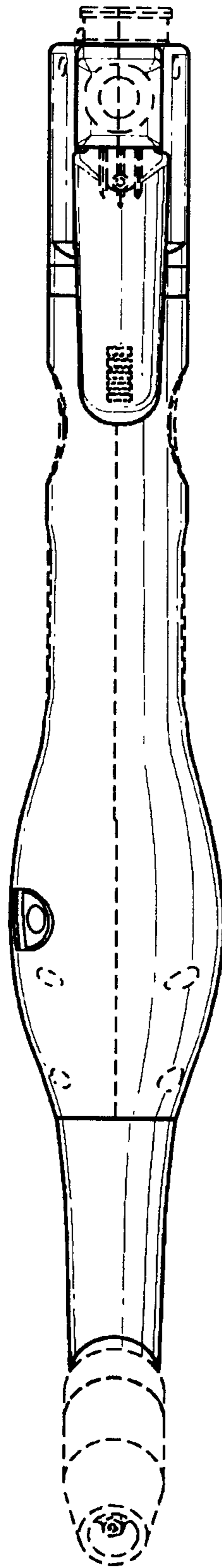

FIG. 12

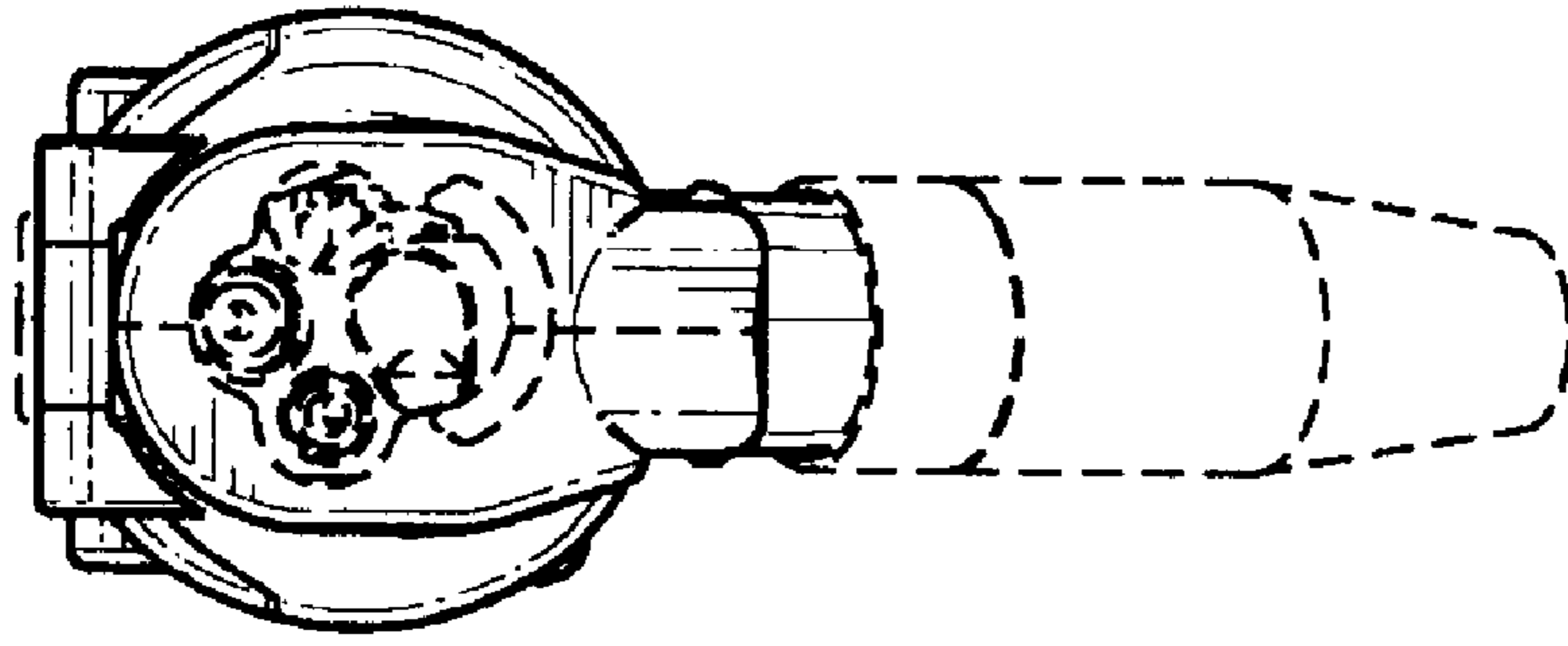

FIG. 13

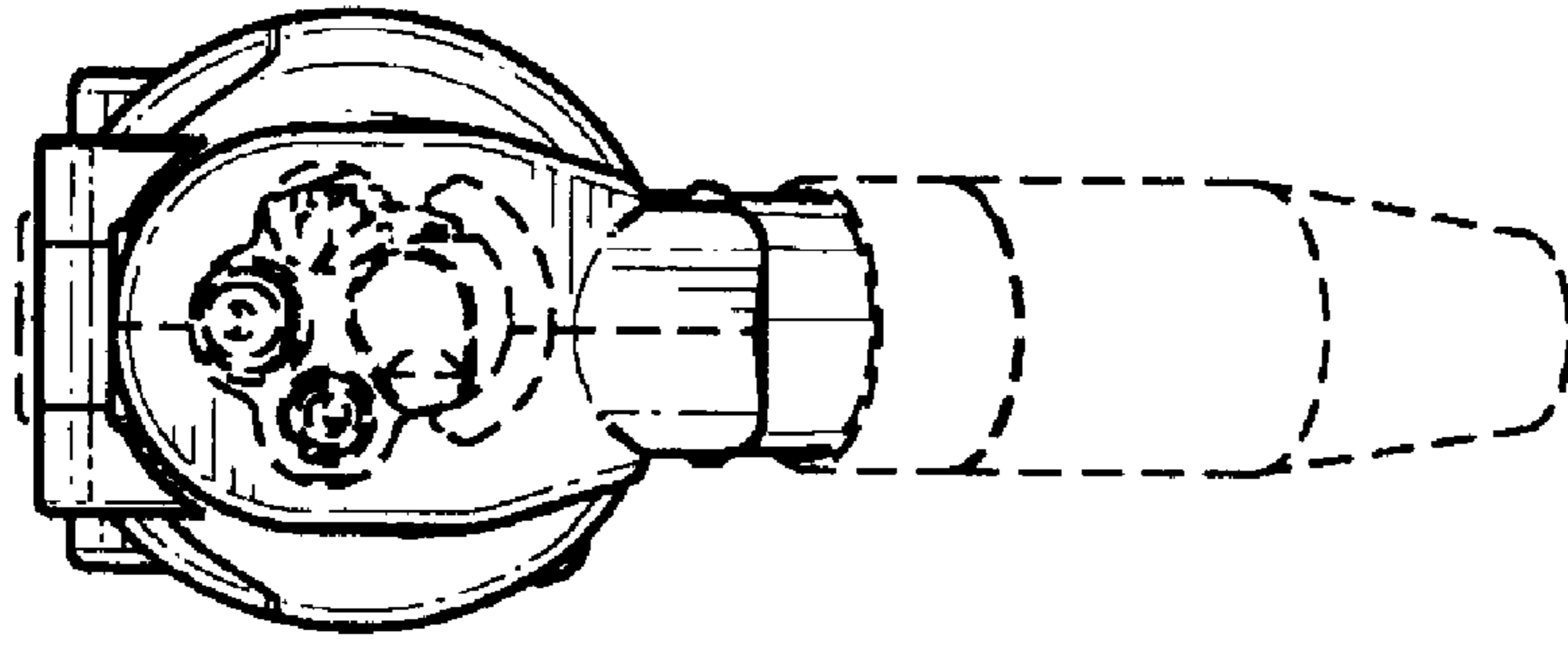

FIG. 14