



US00D535045S

(12) **United States Design Patent**  
**Schiavone et al.**

(10) **Patent No.:** **US D535,045 S**

(45) **Date of Patent:** **\*\* Jan. 9, 2007**

(54) **VEHICLE HEADLIGHT LENS**

(75) Inventors: **Patrick Schiavone**, Bloomfield, MI (US); **Gordon Platto**, Troy, MI (US); **Michael Smith**, Plymouth, MI (US); **Albert Debusschere**, Brighton, MI (US)

(73) Assignee: **Ford Global Technologies, LLC**, Dearborn, MI (US)

(\*\*) Term: **14 Years**

(21) Appl. No.: **29/246,019**

(22) Filed: **Dec. 21, 2005**

(51) **LOC (8) Cl.** ..... **26-06**

(52) **U.S. Cl.** ..... **D26/28**

(58) **Field of Classification Search** ..... D26/28-36;  
362/459-468, 475-478, 485-487

See application file for complete search history.

(56) **References Cited**

**U.S. PATENT DOCUMENTS**

D511,585 S \* 11/2005 Manchester et al. .... D26/28

D519,231 S \* 4/2006 Fisker et al. .... D26/28

**OTHER PUBLICATIONS**

Pickup Truck.com, *Caught! 2005 Ford F-350 Super Duty*, Aug. 4, 2003 <http://www.pickuptruck.com/html/2005/ford/superduty/caught.html>.

Automotive News Online, *Ford modifies '05 F-series Super Duty pickups*, May 24, 2004 <http://www.autonews.com/article.cms?articleId=48362>.

Detroit News Online, *Ford tests a hydrogen F-350*, Sep. 7, 2004 <http://www.detnews.com/2004/autoinsider/0409/07/b01/265187.htm>.

Detroit News Online, *Ford's Super Duty pickups due for major makeover*, Dec. 22, 2004 <http://info.detnews.com/autosinsider/sneakpeek/indes.cfm?id=17263>.

(Continued)

*Primary Examiner*—Marcus A. Jackson

(74) *Attorney, Agent, or Firm*—Damian Porcari

(57) **CLAIM**

The ornamental design for a vehicle headlight lens, as shown and described.

**DESCRIPTION**

FIG. 1 is a frontal perspective view of the right vehicle headlight lens, attached to a vehicle, no part of the vehicle is claimed;

FIG. 2 is a frontal perspective view of the right vehicle headlight lens;

FIG. 3 is a front elevational view of the right vehicle headlight lens;

FIG. 4 is a right side elevational view of the right vehicle headlight lens;

FIG. 5 is a left side elevational view of a right vehicle headlight lens;

FIG. 6 is a top down plan view of the right vehicle headlight lens;

FIG. 7 is a bottom up plan view of the right vehicle headlight lens;

FIG. 8 is a frontal perspective view of an alternative embodiment of the vehicle headlight lens illustrated in FIGS. 1-7, showing a left vehicle headlight lens, attached to a vehicle, no part of the vehicle is claimed;

FIG. 9 is a frontal perspective view of the left vehicle headlight lens;

FIG. 10 is a front elevational view of the left vehicle headlight lens;

FIG. 11 is a left side elevational view of the left vehicle headlight lens;

FIG. 12 is a right side elevational view of the left vehicle headlight lens;

FIG. 13 is a top down plan view of the left vehicle headlight lens; and,

FIG. 14 is a bottom up plan view of the left vehicle headlight lens.

The phantom lines are not a part of the claimed invention.

**1 Claim, 14 Drawing Sheets**

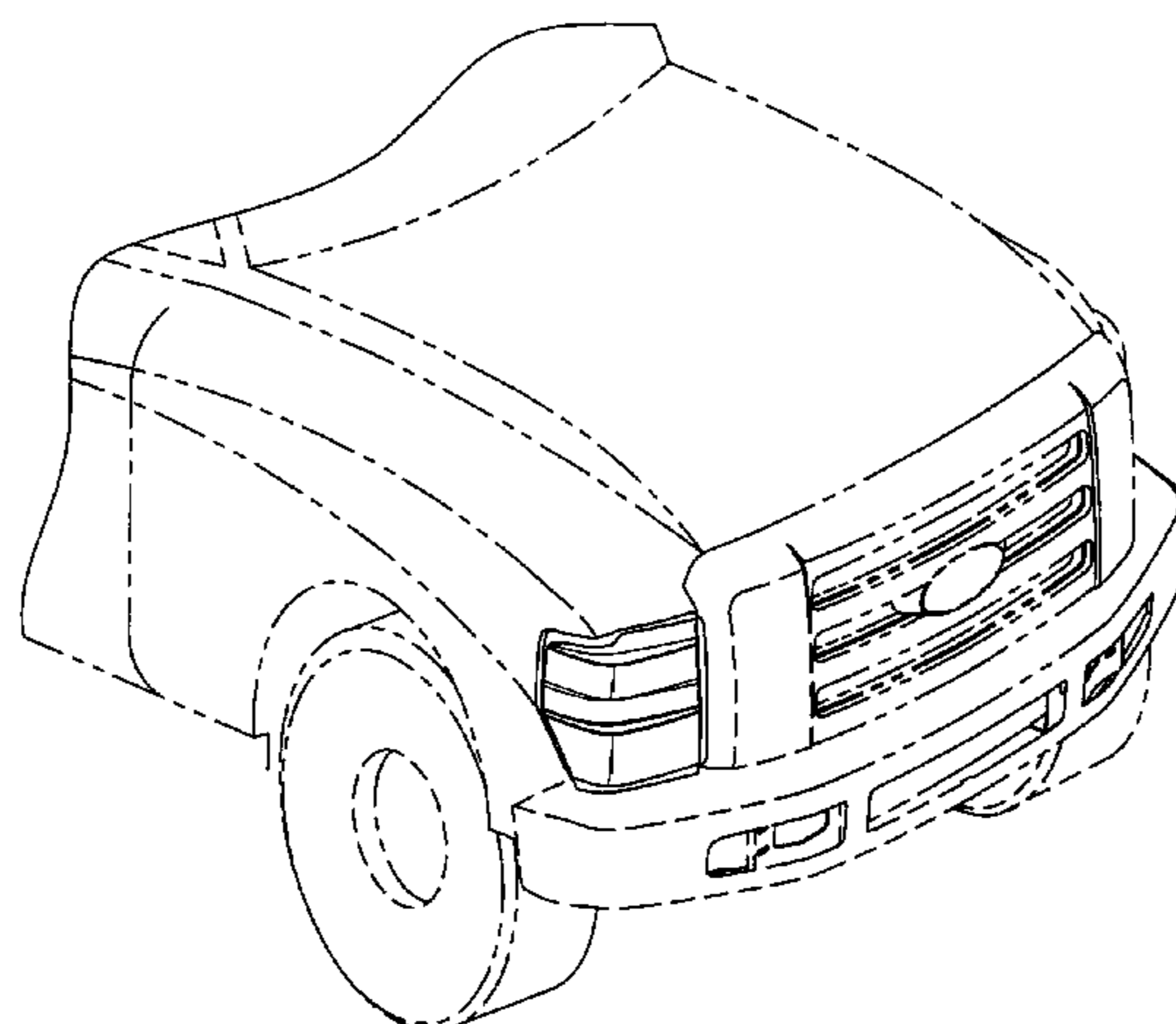

OTHER PUBLICATIONS

FordForums.com, *US: Spy Shot: 2007 Ford F-Series Super Duty*, Dec. 24, 2004 <http://www.fordforums.com/showthread.php?t=93973>.

Motor Trend's Truck Trend, News Front: *Spied—2007 Super Duty*, p. 16, Mar./Apr. 2005.

CarSpyShots.net, *2007 Ford SuperDutys (f250, f350)*, 047/23/2005 <http://carspyshots.net/zerthread?id=16073>.

CarSpyShots.net, *Re: (CD-BP)*, Sep. 1, 2005 <http://www.carspyshots.net/zerthread?id=16073>.

TheCarConnection.com, *Ford Excursion Sinks into History*, Sep. 25, 2005 [http://www.thecarconnection.com/Auto\\_News/Daily\\_Edition/Daily\\_Edition\\_Sept\\_30%20Oct\\_3\\_2005.S173.A9375.html](http://www.thecarconnection.com/Auto_News/Daily_Edition/Daily_Edition_Sept_30%20Oct_3_2005.S173.A9375.html).

The Detroit News (detnews.com), Autos Insider: *Out of Gas: Ford's fuel-guzzling Excursion reaches end of line*, Sep. 30, 2005 <http://detnews.com/2005/autosinsider/0509/30/c01-332800.htm?r=truckblog.com>.

Edmunds.com, *2007 Ford F250/F350 Large Truck*, date unknown <http://www.edmunds.com/future/2007/ford/f250f350/100491426/preview.html>.

Edmunds.com, *Inside Line: 2005 Excursion*, date unknown <http://www.edmunds.com/insideline/do/ViewModelDetail/make=Ford/model=Excursion>.

Ford Vehicles, *2005 Ford Excursion*, date unknown <http://www.fordvehicles.com/suvs/exuursion/>.

\* cited by examiner

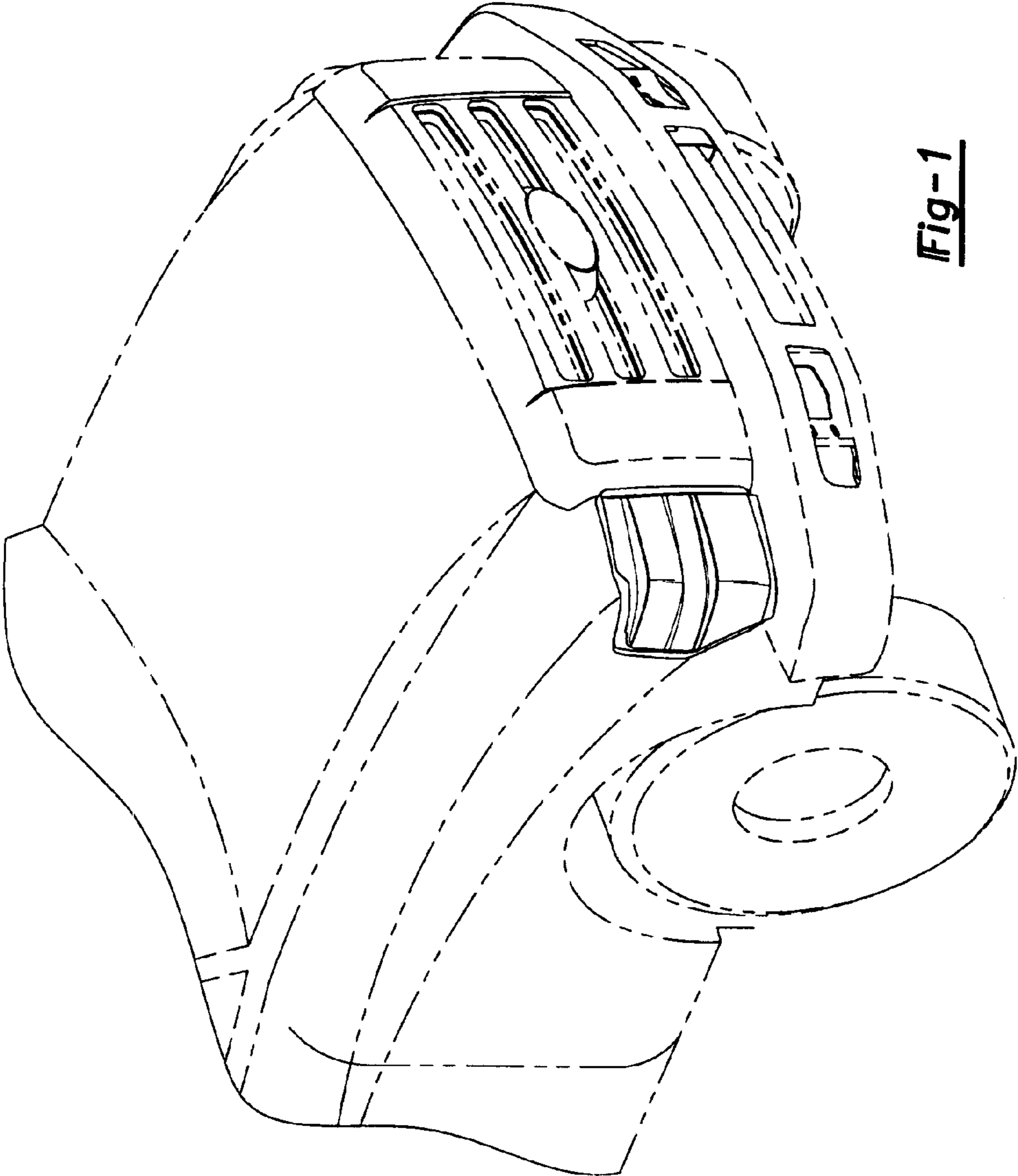

Fig-1

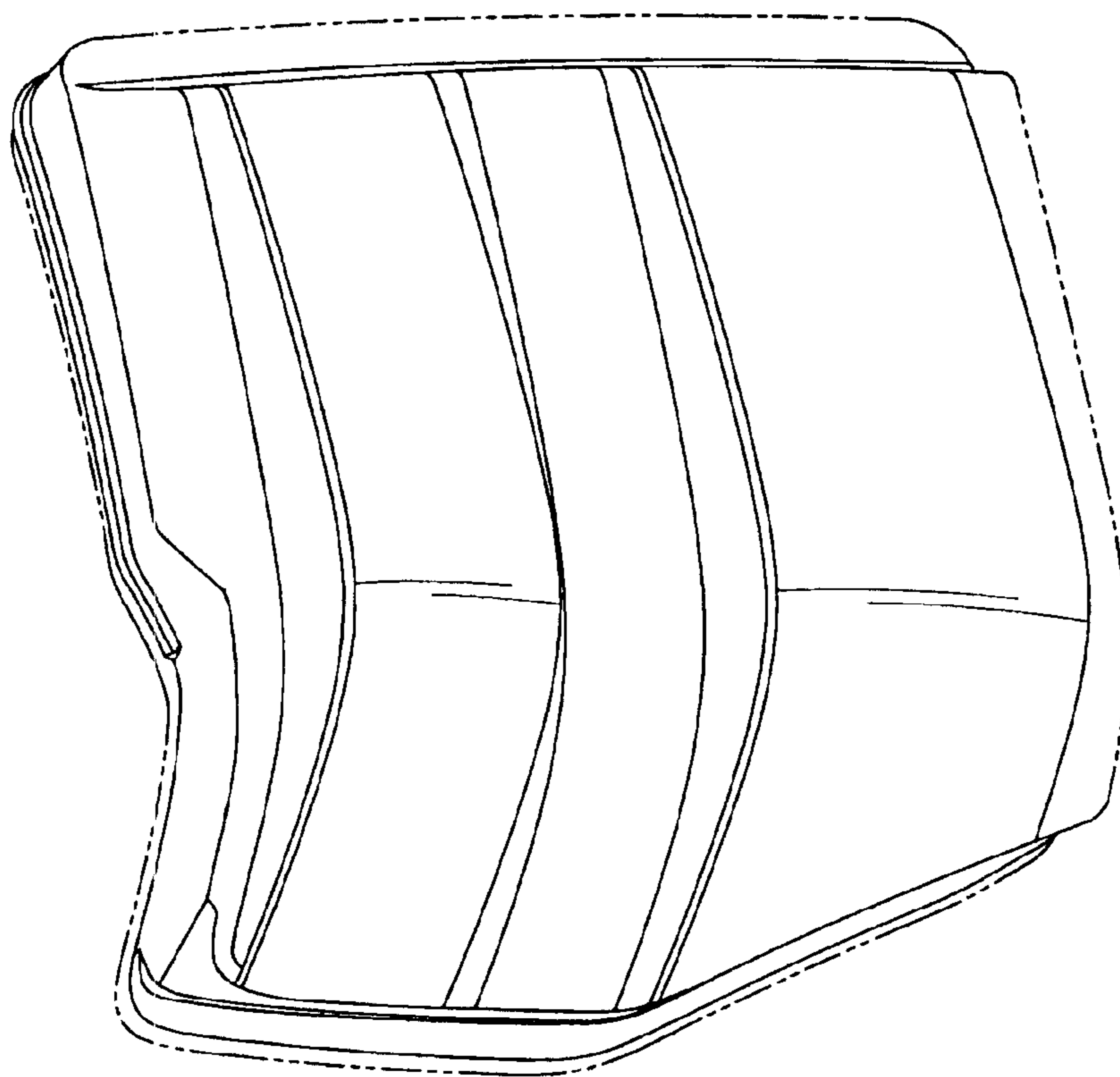

Fig-2

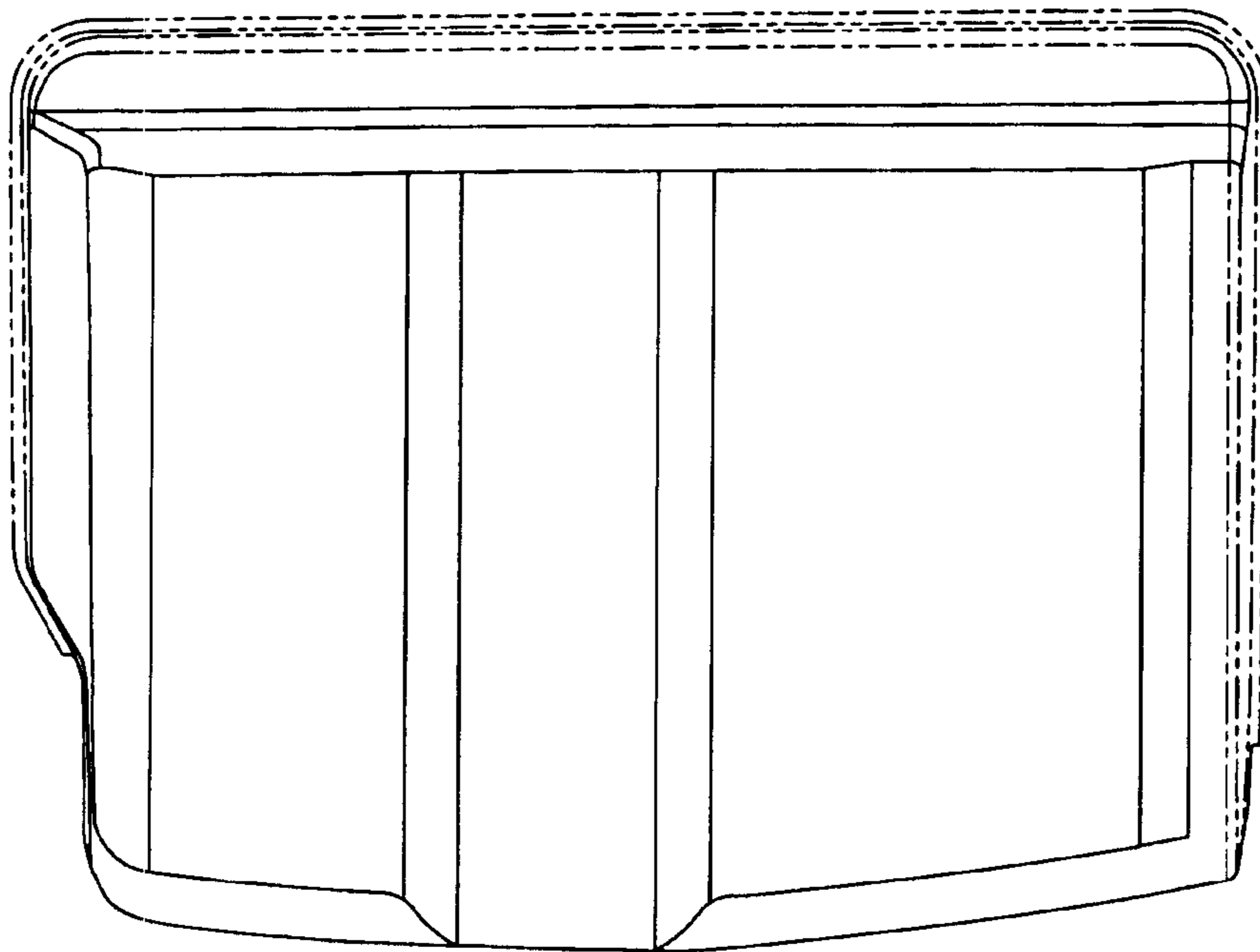

Fig-3

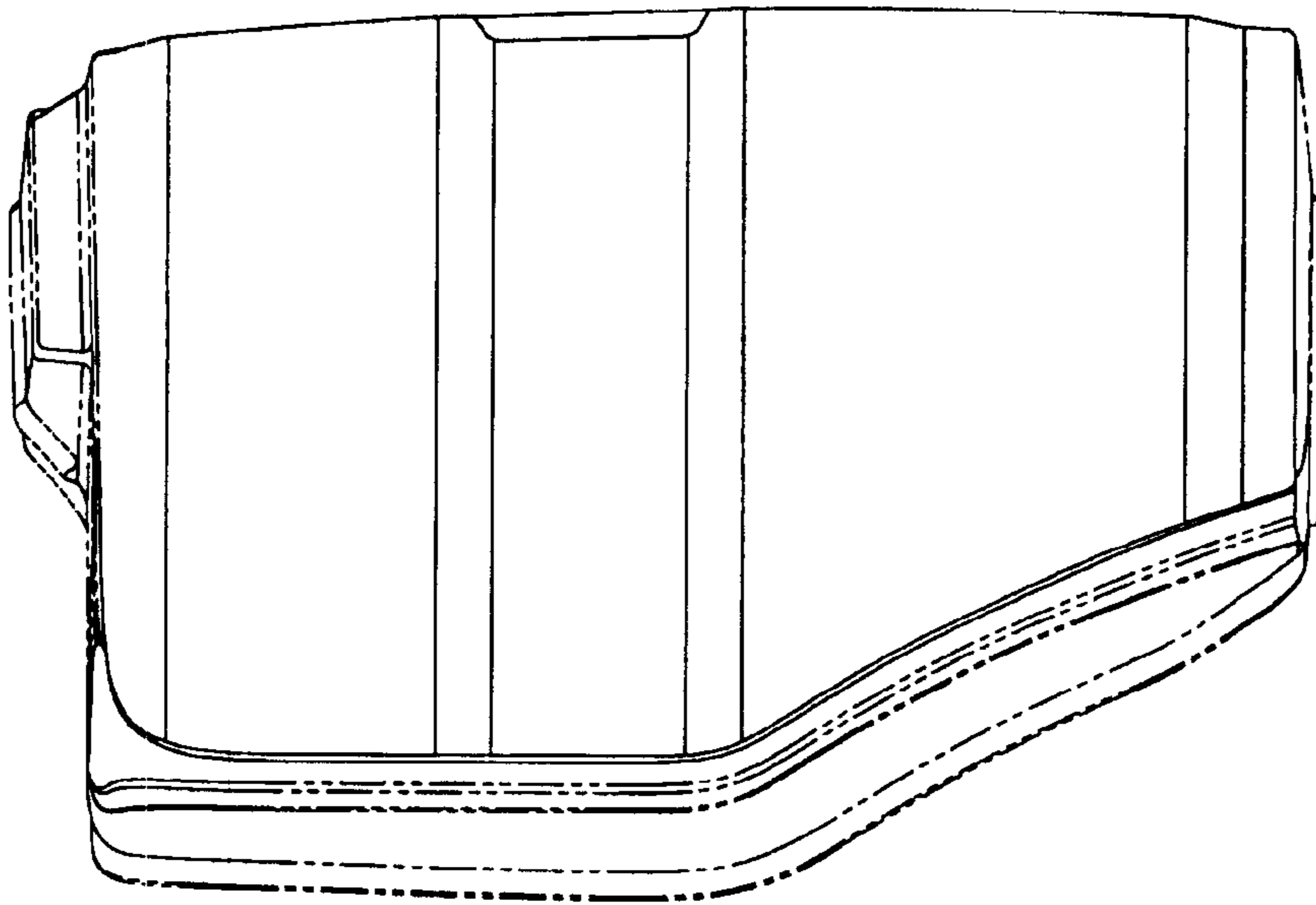

Fig-4

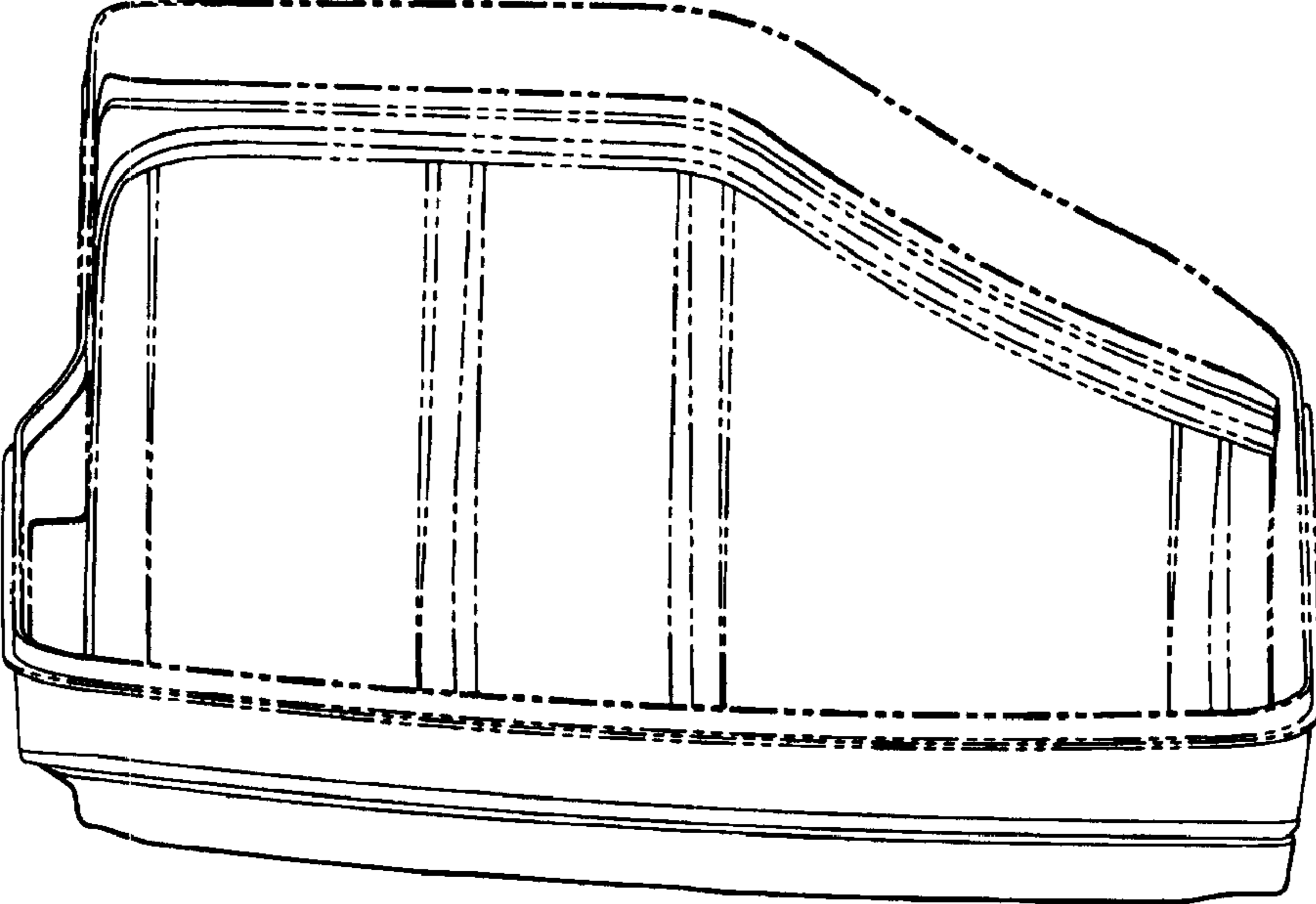

Fig-5

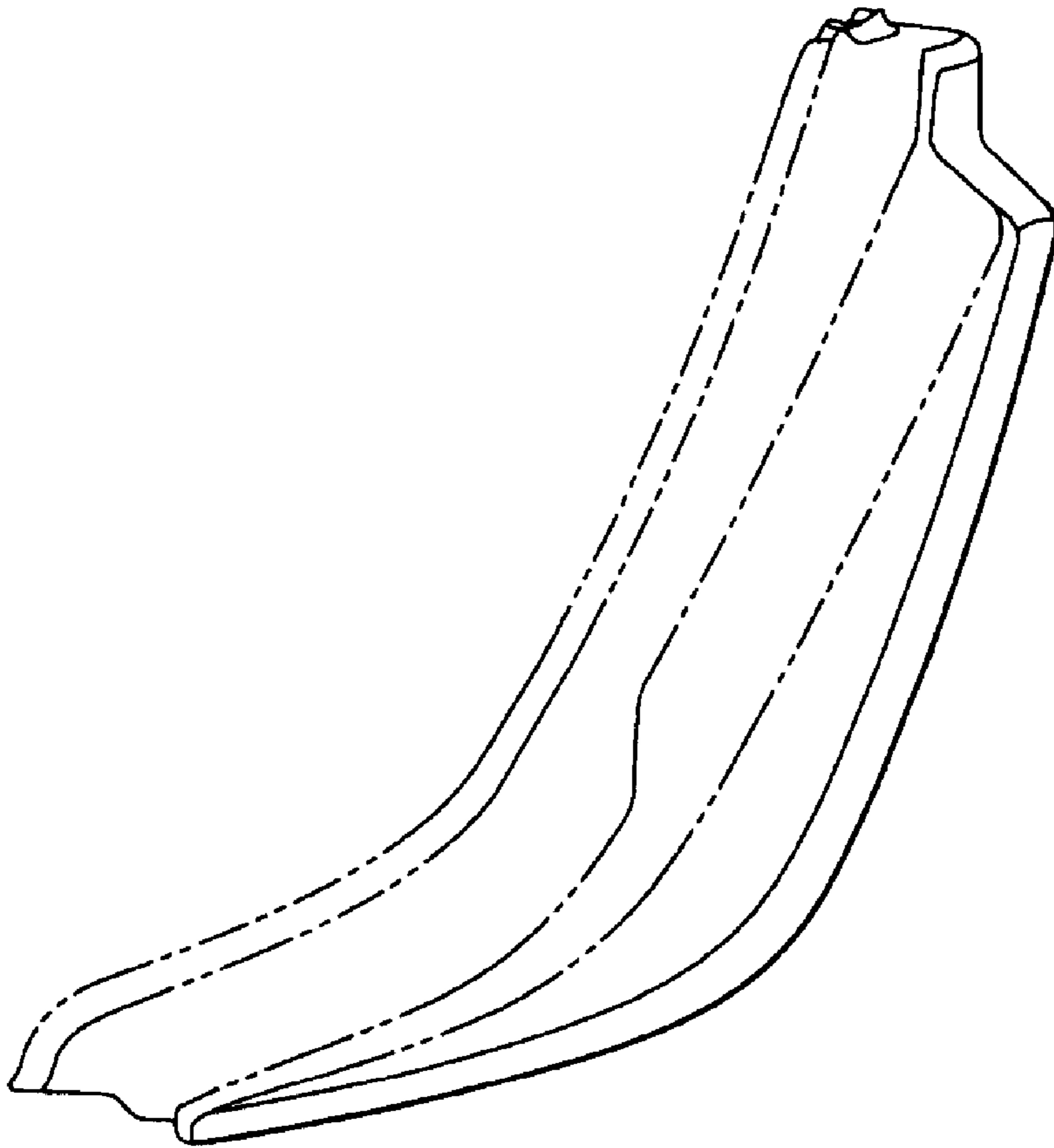

Fig-6



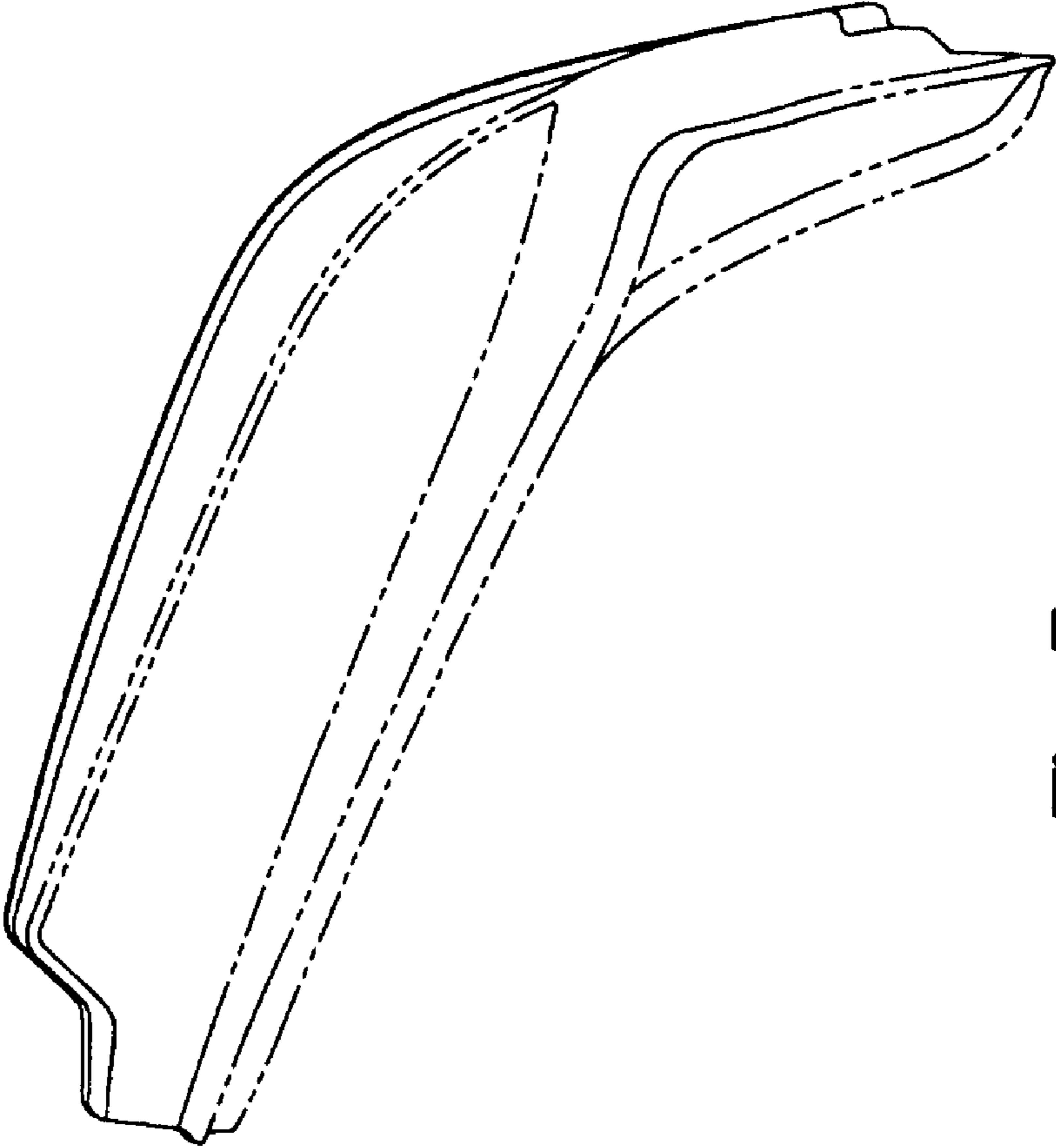

Fig-7

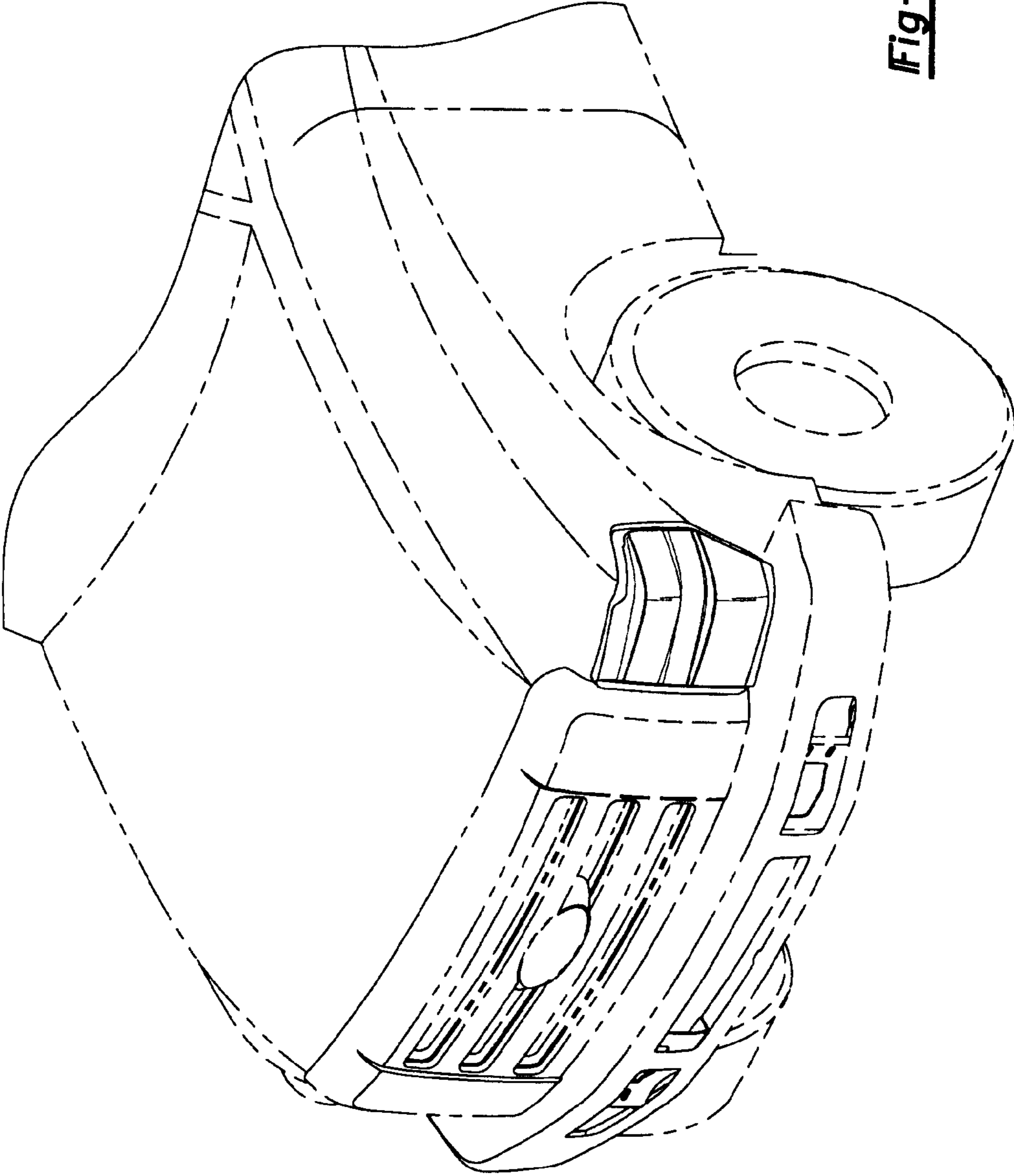

Fig-8

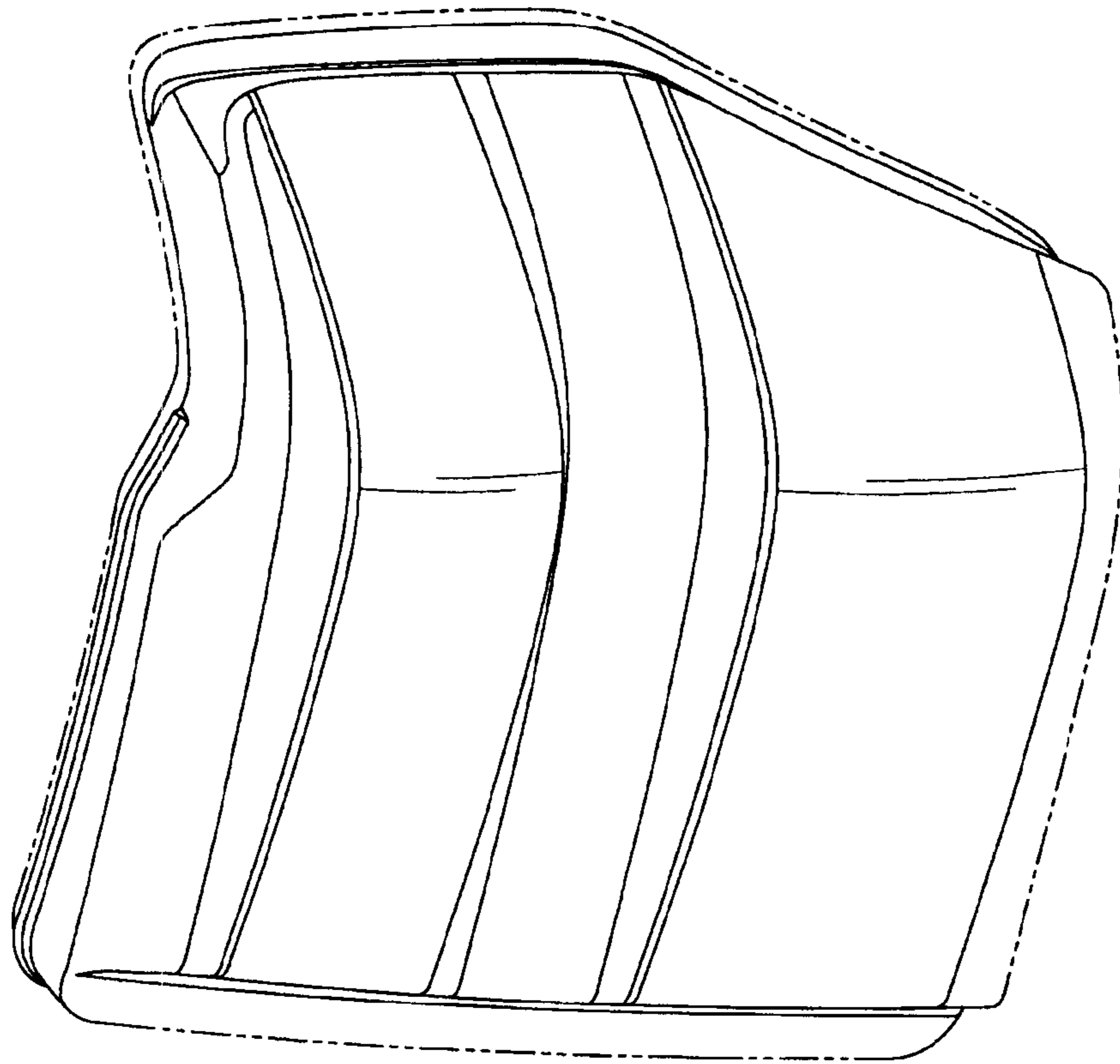

Fig-9

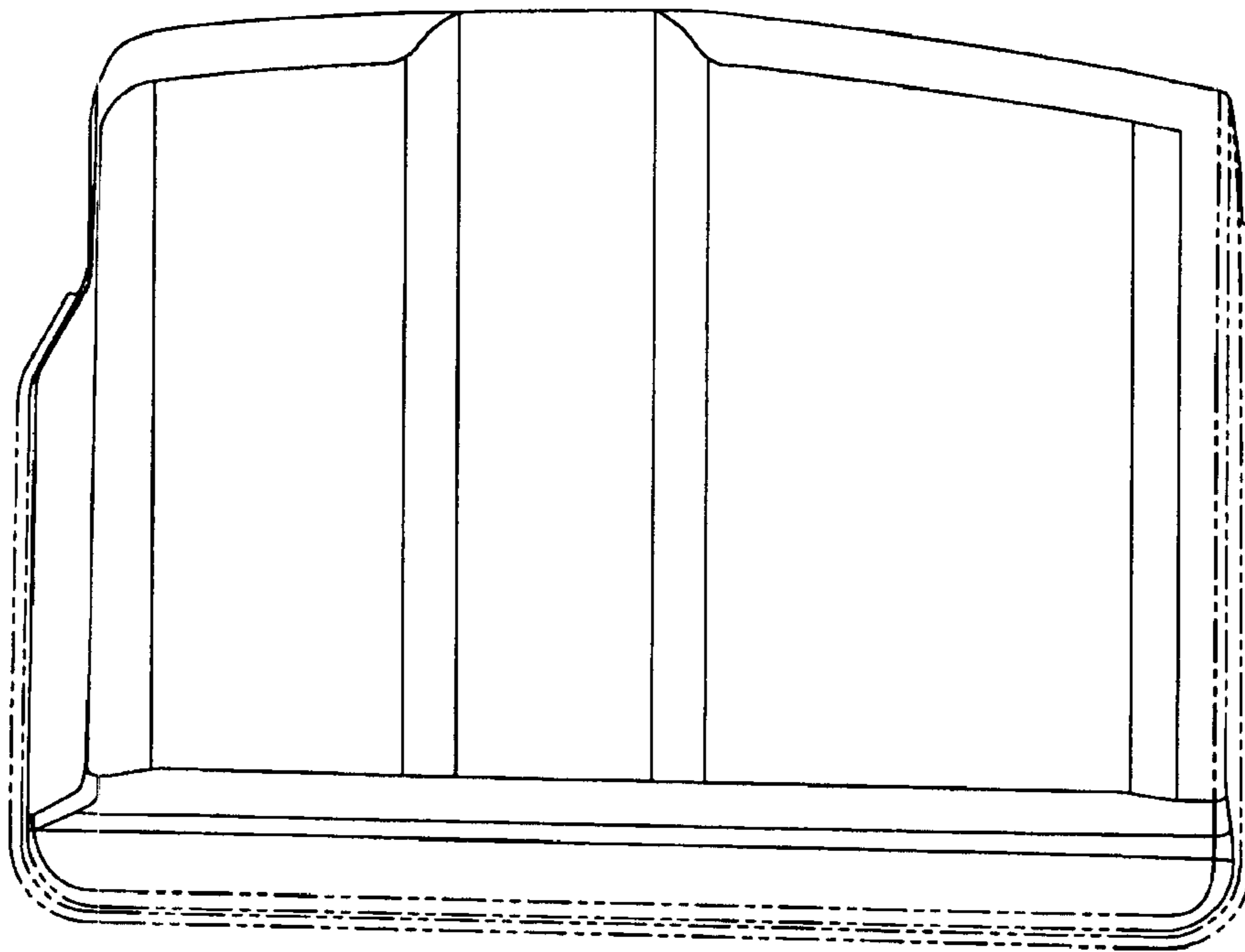

Fig-10

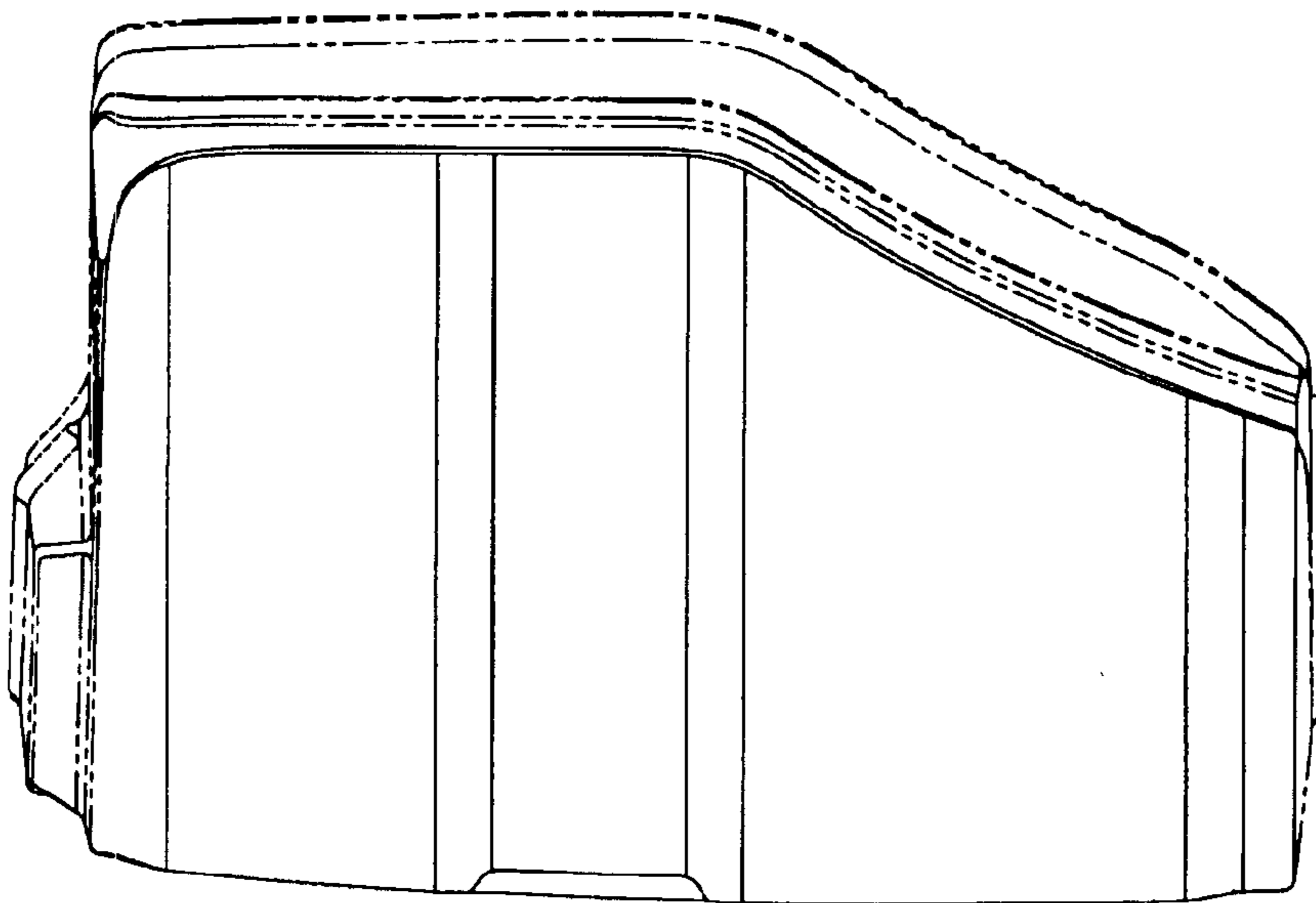

Fig-11

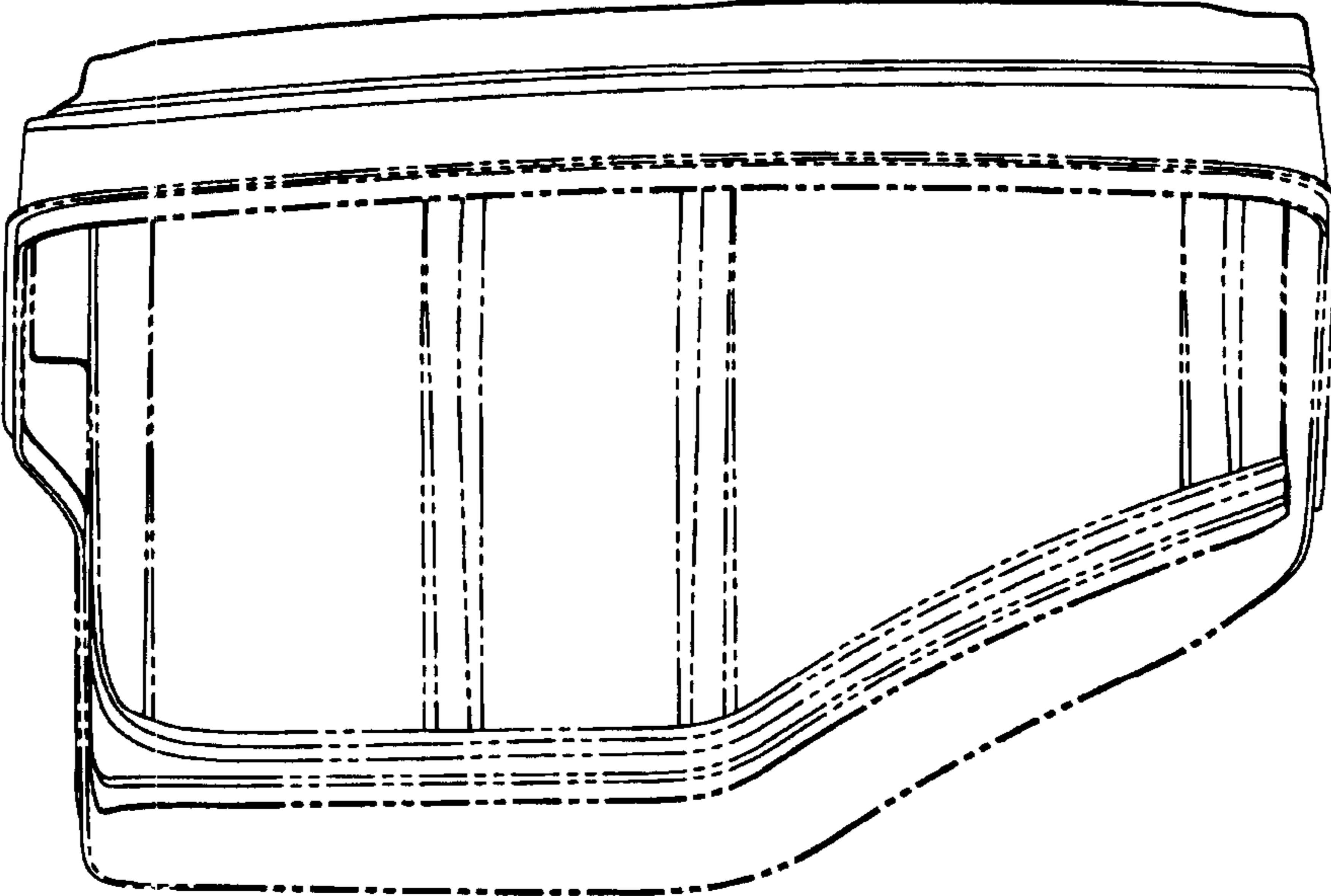
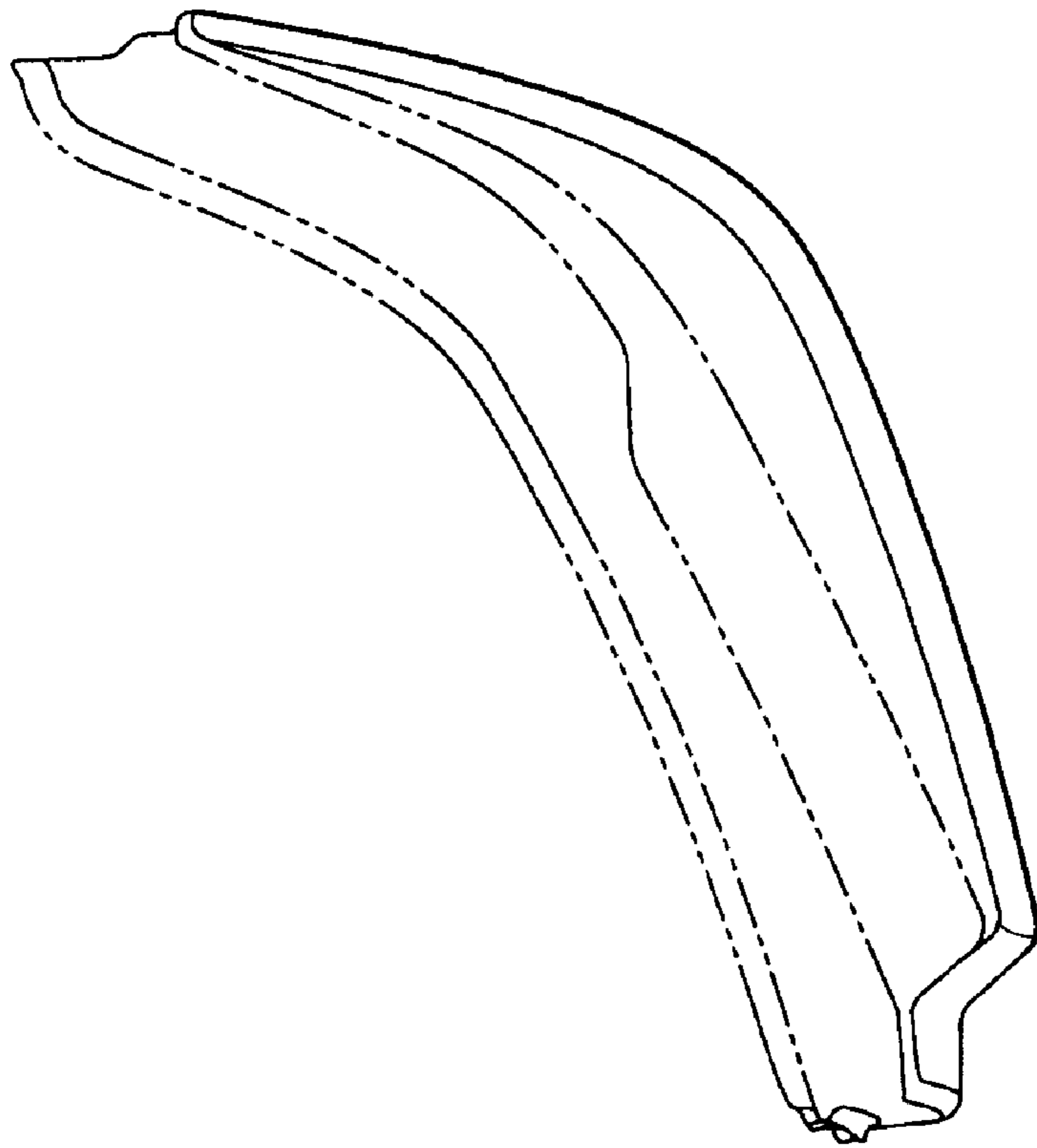

Fig-12



**Fig-13**

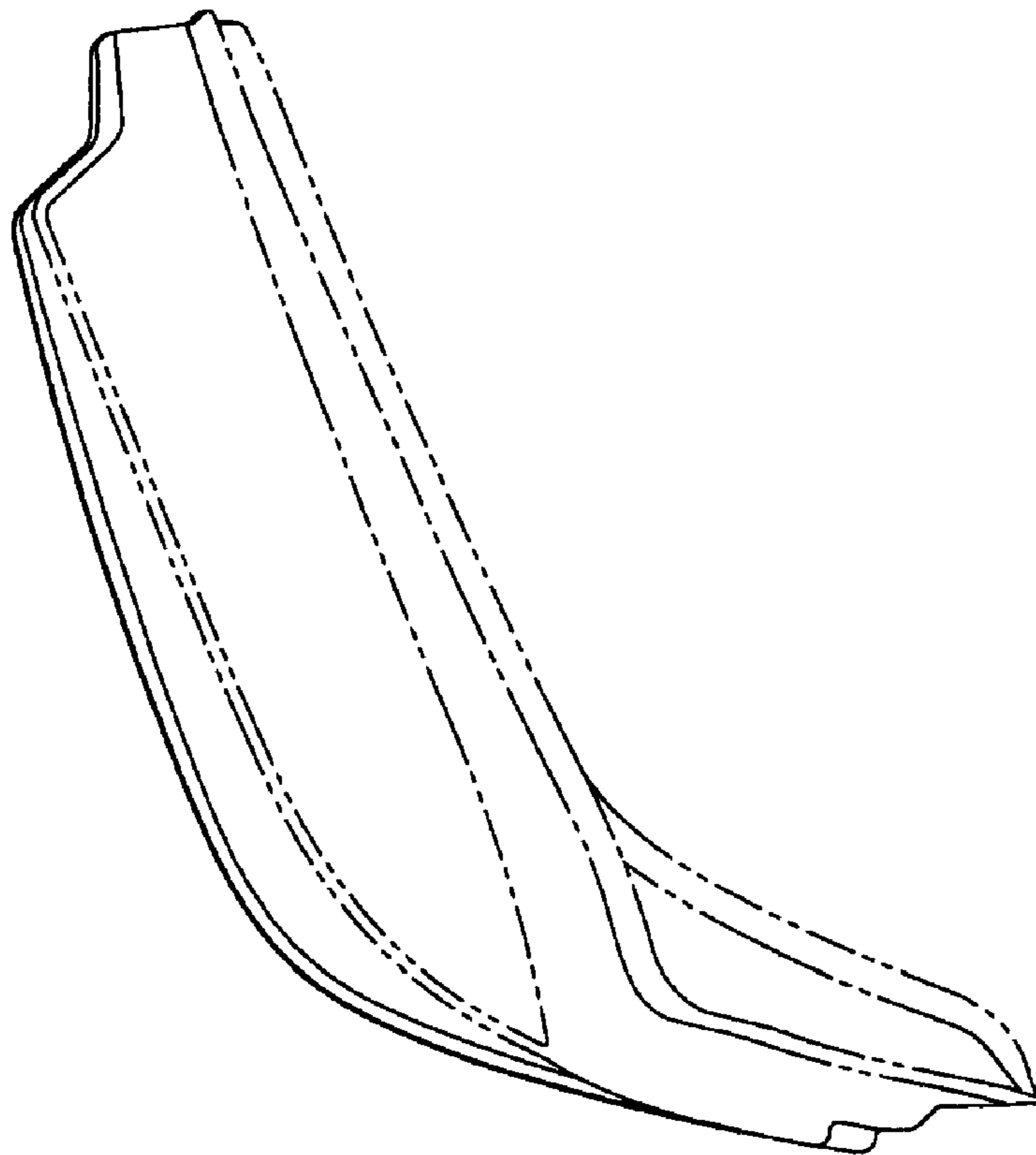

Fig-14