

US00D534968S

(12) **United States Design Patent**
Proch

(10) **Patent No.:** **US D534,968 S**

(45) **Date of Patent:** **** Jan. 9, 2007**

(54) **WHEEL FOR A TOY VEHICLE**
(75) Inventor: **Nathan Proch**, Los Angeles, CA (US)
(73) Assignee: **Mattel, Inc.**, El Segundo, CA (US)
(**) Term: **14 Years**

(21) Appl. No.: **29/226,773**
(22) Filed: **Mar. 31, 2005**

(51) **LOC (8) Cl.** **21-01**
(52) **U.S. Cl.** **D21/563**
(58) **Field of Classification Search** D21/533,
D21/548-551, 559, 561-563, 760, 763-765,
D21/771, 779; D12/86, 88, 93, 159, 204,
D12/209; 446/454-457, 465, 466, 469, 470,
446/431

See application file for complete search history.

(56) **References Cited**

U.S. PATENT DOCUMENTS

D261,406 S * 10/1981 Corbin D21/779
D316,731 S * 5/1991 Tsuchiya D21/550
D414,834 S * 10/1999 Keleny D21/779
D420,637 S * 2/2000 Glade D12/209
D421,083 S * 2/2000 Chen D21/779
D433,476 S * 11/2000 Lin D21/779

D439,285 S * 3/2001 Chen et al. D21/563
D466,067 S * 11/2002 Muzzarelli D12/211
D466,852 S * 12/2002 Pfeiffer et al. D12/211
D481,982 S * 11/2003 Takechi D12/211

* cited by examiner

Primary Examiner—Holly H. Baynham

Assistant Examiner—Cynthia M. Chin

(74) *Attorney, Agent, or Firm*—Alleman Hall McCoy
Russell & Tuttle LLP

(57) **CLAIM**

The ornamental design for a wheel for a toy vehicle, as shown and described.

DESCRIPTION

FIG. 1 is a front perspective view of a wheel for a toy vehicle showing my new design.

FIG. 2 is a top view thereof; and,

FIG. 3 is a rear perspective view thereof.

The broken or dashed lines shown in the drawings are for illustrative purposes only and form no part of the claimed design.

The shading lines shown in the drawings represent the three-dimensional contour of the design, and are not intended to indicate surface decoration.

1 Claim, 1 Drawing Sheet

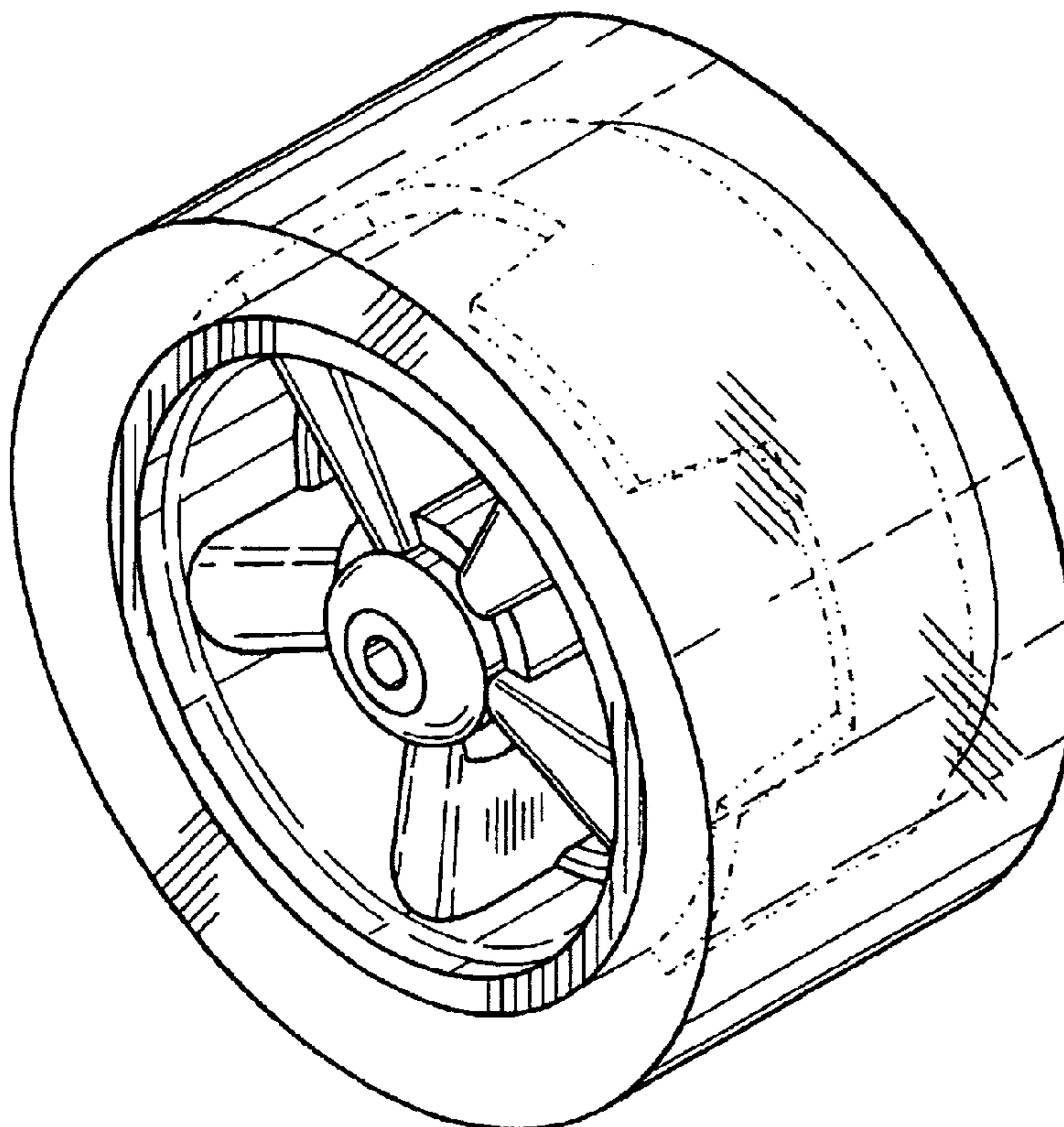

Fig. 1

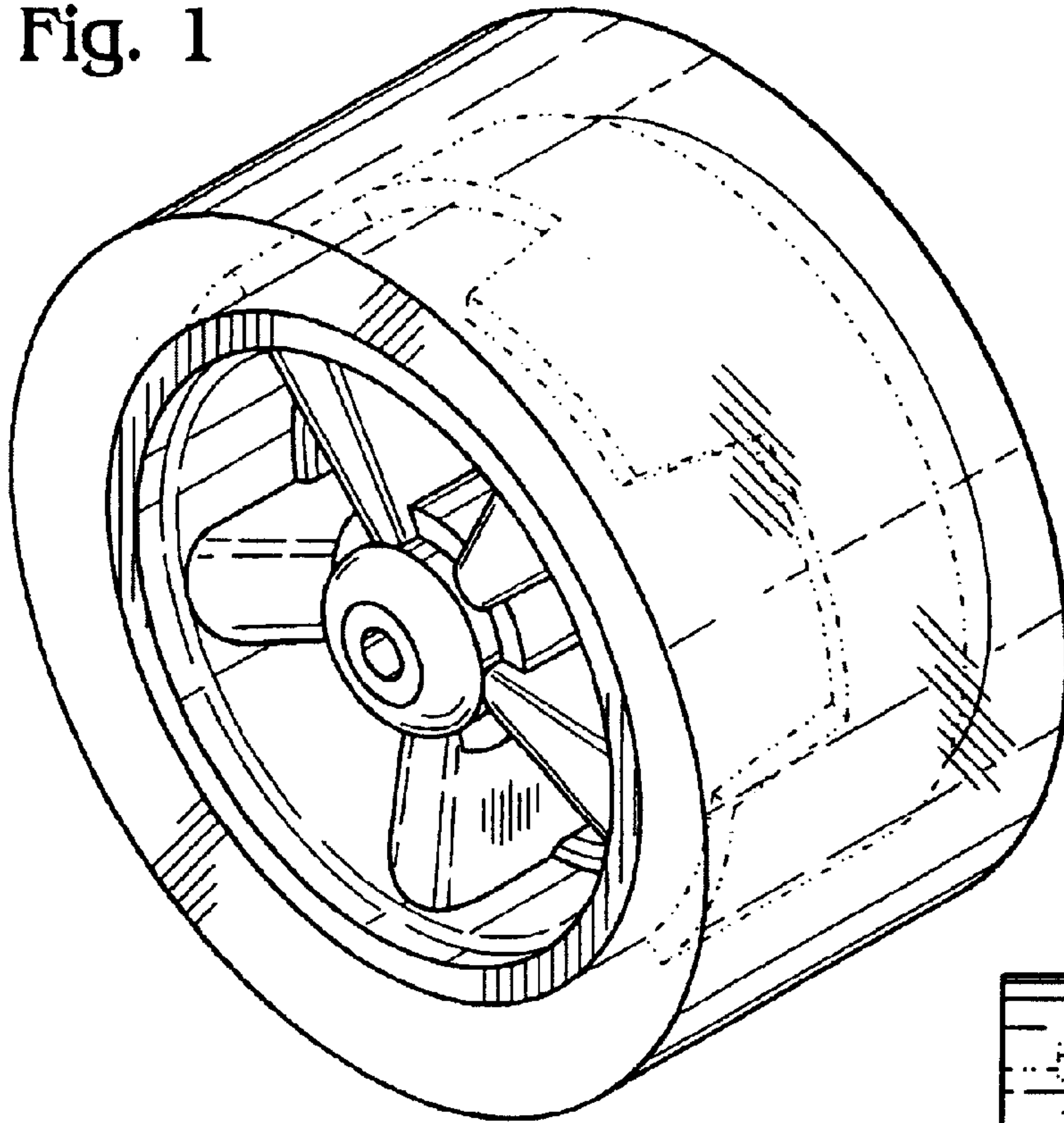

Fig. 3

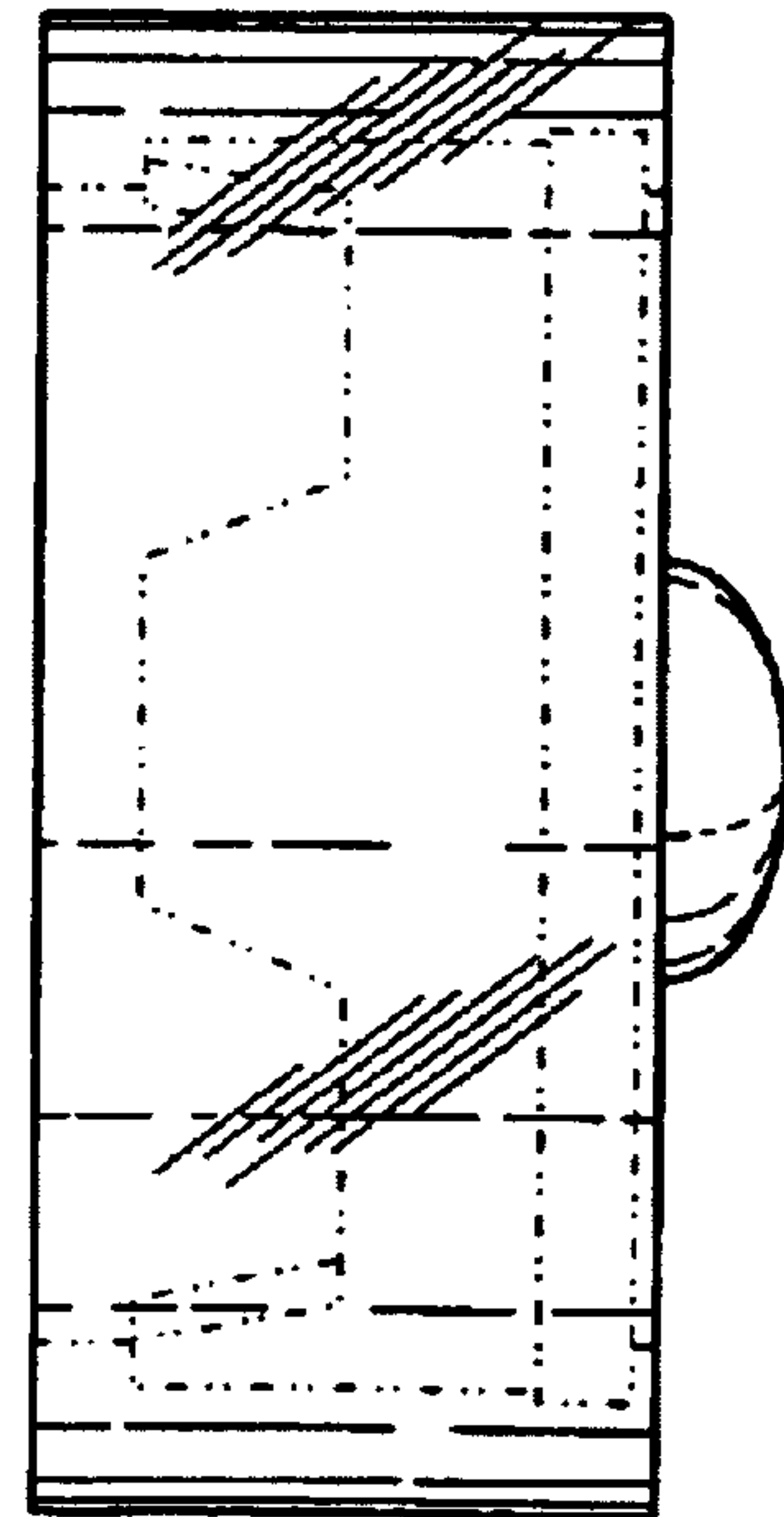
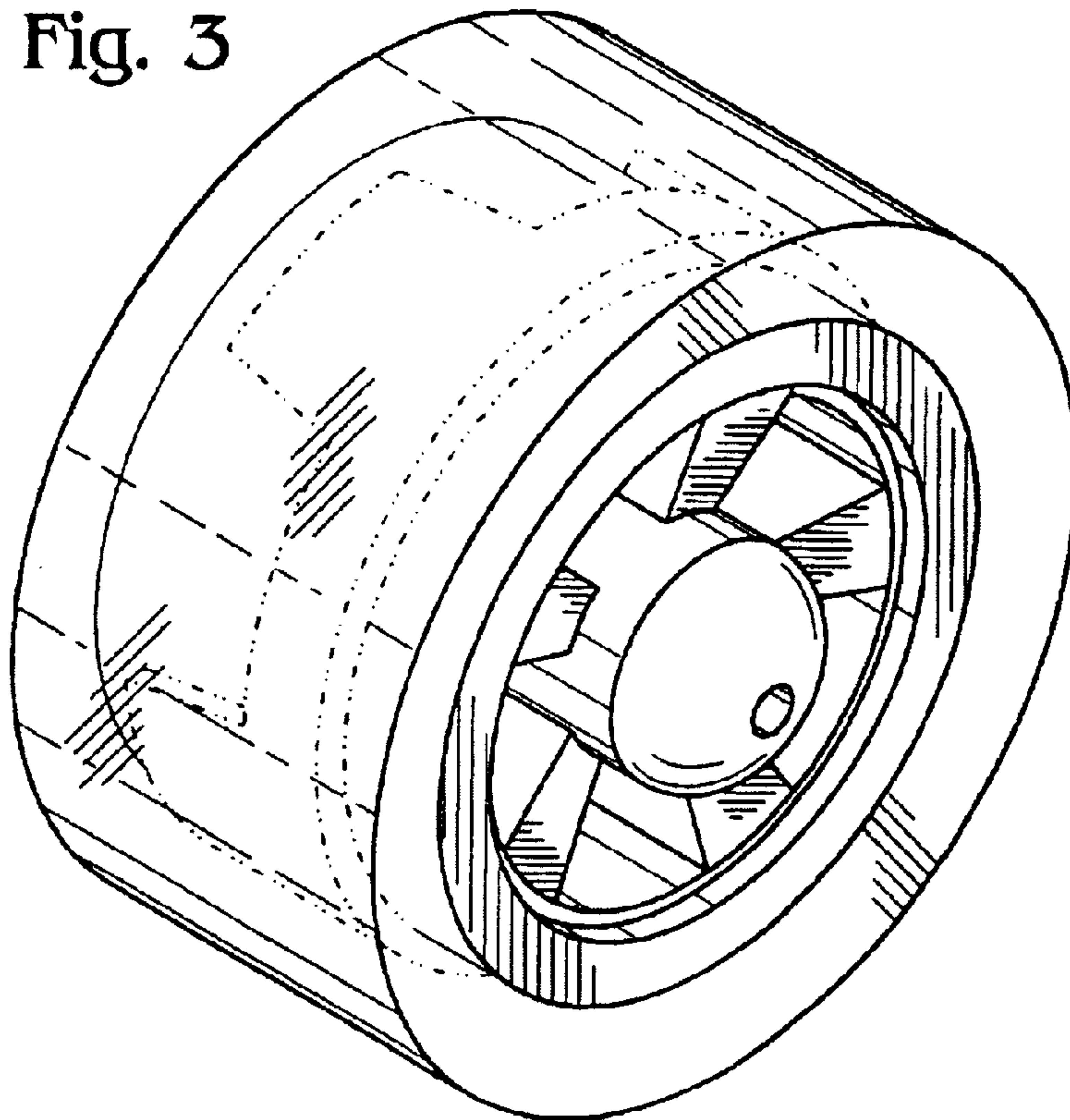

Fig. 2