



US00D534245S

(12) **United States Design Patent**
Egli et al.

(10) **Patent No.:** **US D534,245 S**

(45) **Date of Patent:** **** Dec. 26, 2006**

(54) **MIXER TAP FOR A KITCHEN SINK**

(75) Inventors: **Werner Egli**, Hüntwangen (CH);
Winfried Noth, Schwäbisch Gmünd
(CH)

(73) Assignee: **arwa, AG**, Wallisellen (CH)

(**) Term: **14 Years**

(21) Appl. No.: **29/257,569**

(22) Filed: **Apr. 7, 2006**

(30) **Foreign Application Priority Data**

Oct. 7, 2005 (WO) DM/067 211

(51) **LOC (8) Cl.** **23-01**

(52) **U.S. Cl.** **D23/238**

(58) **Field of Classification Search** D23/238-257;
4/675-678; 137/801

See application file for complete search history.

(56) **References Cited**

U.S. PATENT DOCUMENTS

D281,095 S	*	10/1985	Arnold et al.	D23/238
D314,040 S	*	1/1991	Heieck	D23/238
D466,979 S	*	12/2002	Shulz	D23/238
D481,445 S	*	10/2003	Haug et al.	D23/238
D482,102 S	*	11/2003	Wettstein et al.	D23/238

* cited by examiner

Primary Examiner—Louis S. Zarfes

Assistant Examiner—Gregory Andoll

(74) *Attorney, Agent, or Firm*—Sughrue Mion, PLLC

(57) **CLAIM**

The ornamental design for a mixer tap for a kitchen sink, as shown and described.

DESCRIPTION

FIG. 1 is a perspective view of the top front and right side of a mixer tap for a kitchen sink according to a first embodiment showing our new design;

FIG. 2 is a front elevational view thereof;

FIG. 3 is a rear elevational view thereof;

FIG. 4 is a right side elevational view thereof;

FIG. 5 is a left side elevational view thereof;

FIG. 6 is a top plan view thereof;

FIG. 7 is a bottom plan view thereof;

FIG. 8 is a perspective view of the top front and right side of a mixer tap for a kitchen sink according to a second embodiment;

FIG. 9 is a front elevational view thereof;

FIG. 10 is a rear elevational view thereof;

FIG. 11 is a right side elevational view thereof;

FIG. 12 is a left side elevational view thereof;

FIG. 13 is a top plan view thereof; and,

FIG. 14 is a bottom plan view thereof.

1 Claim, 8 Drawing Sheets

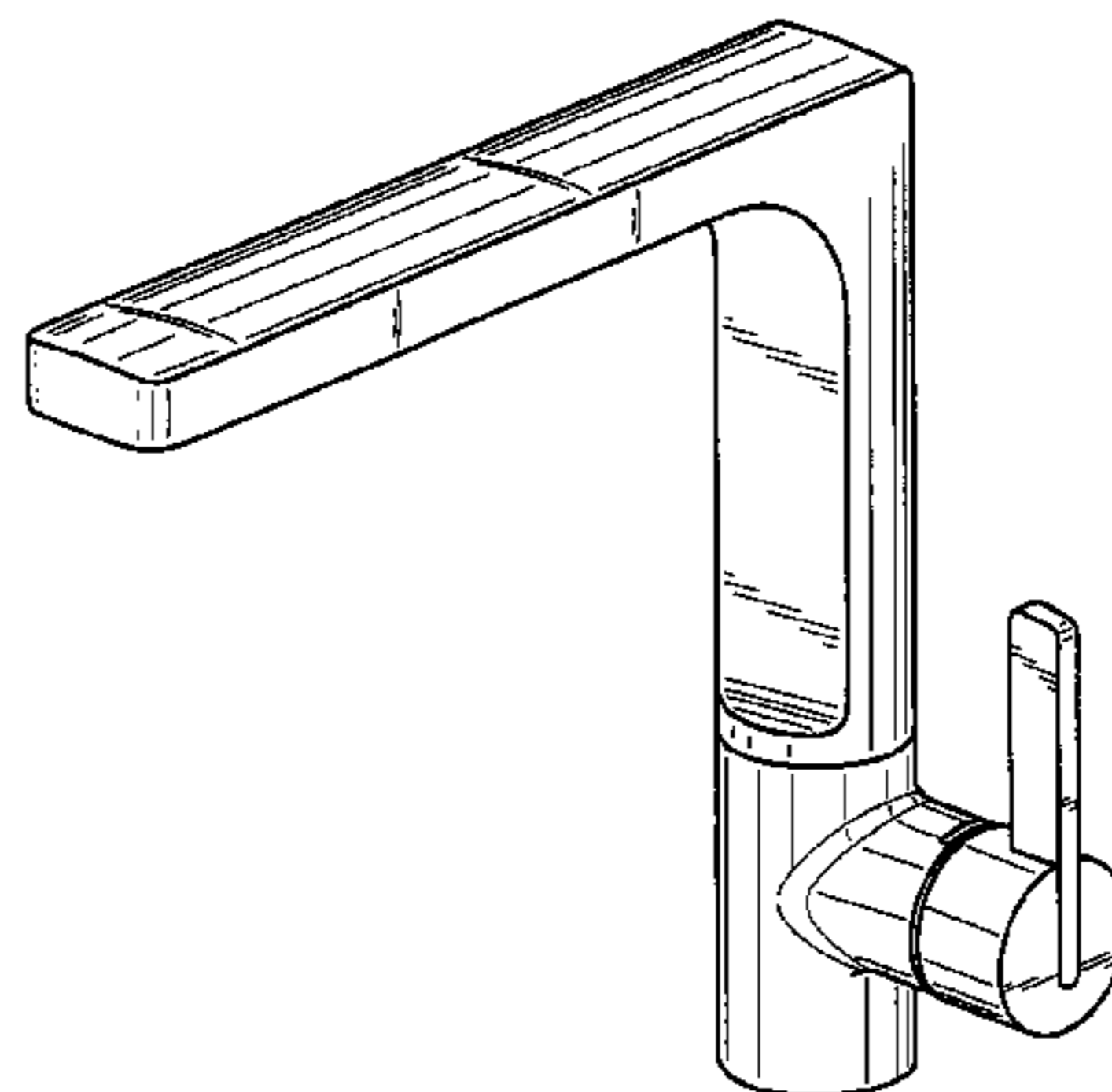
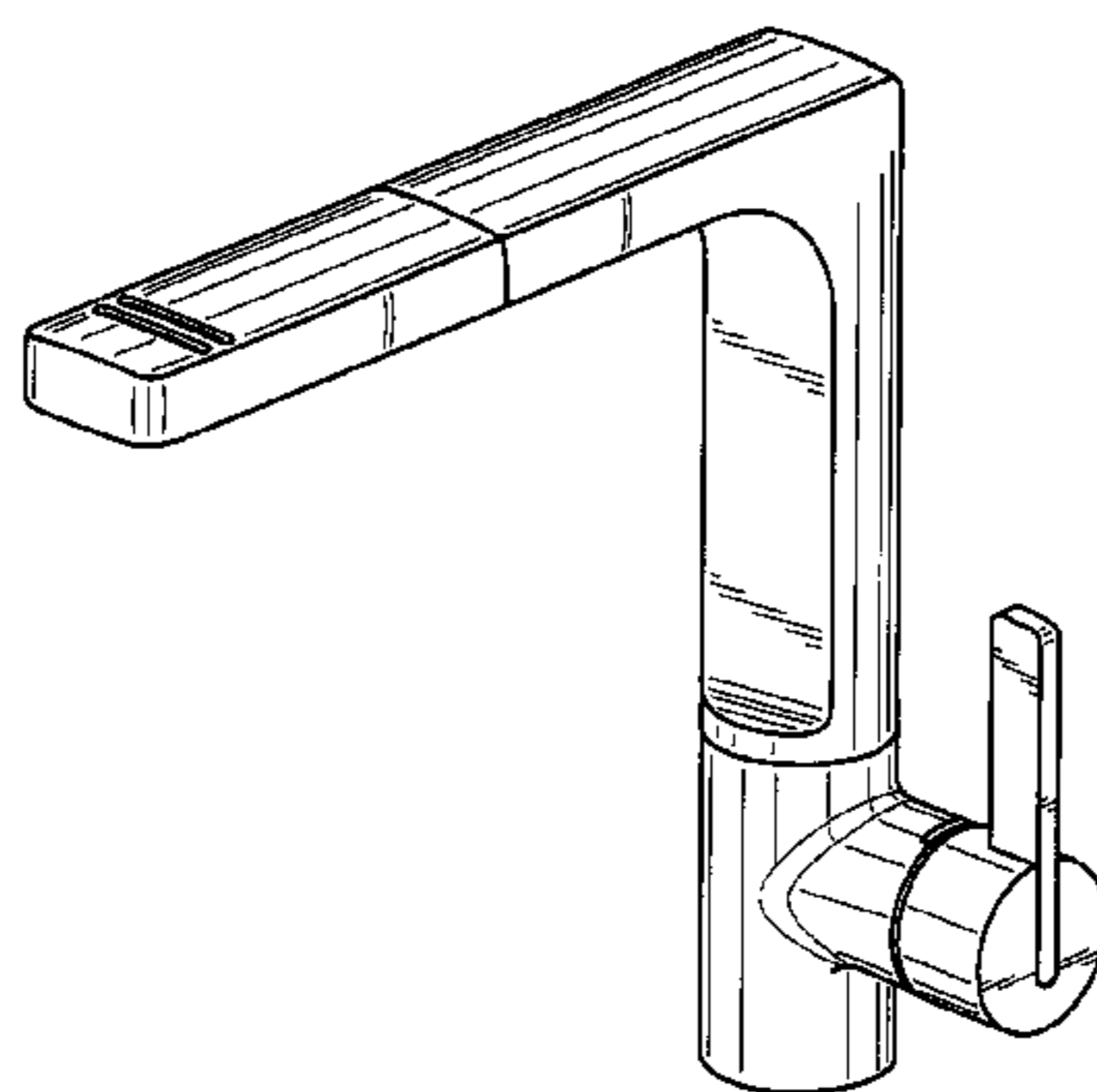

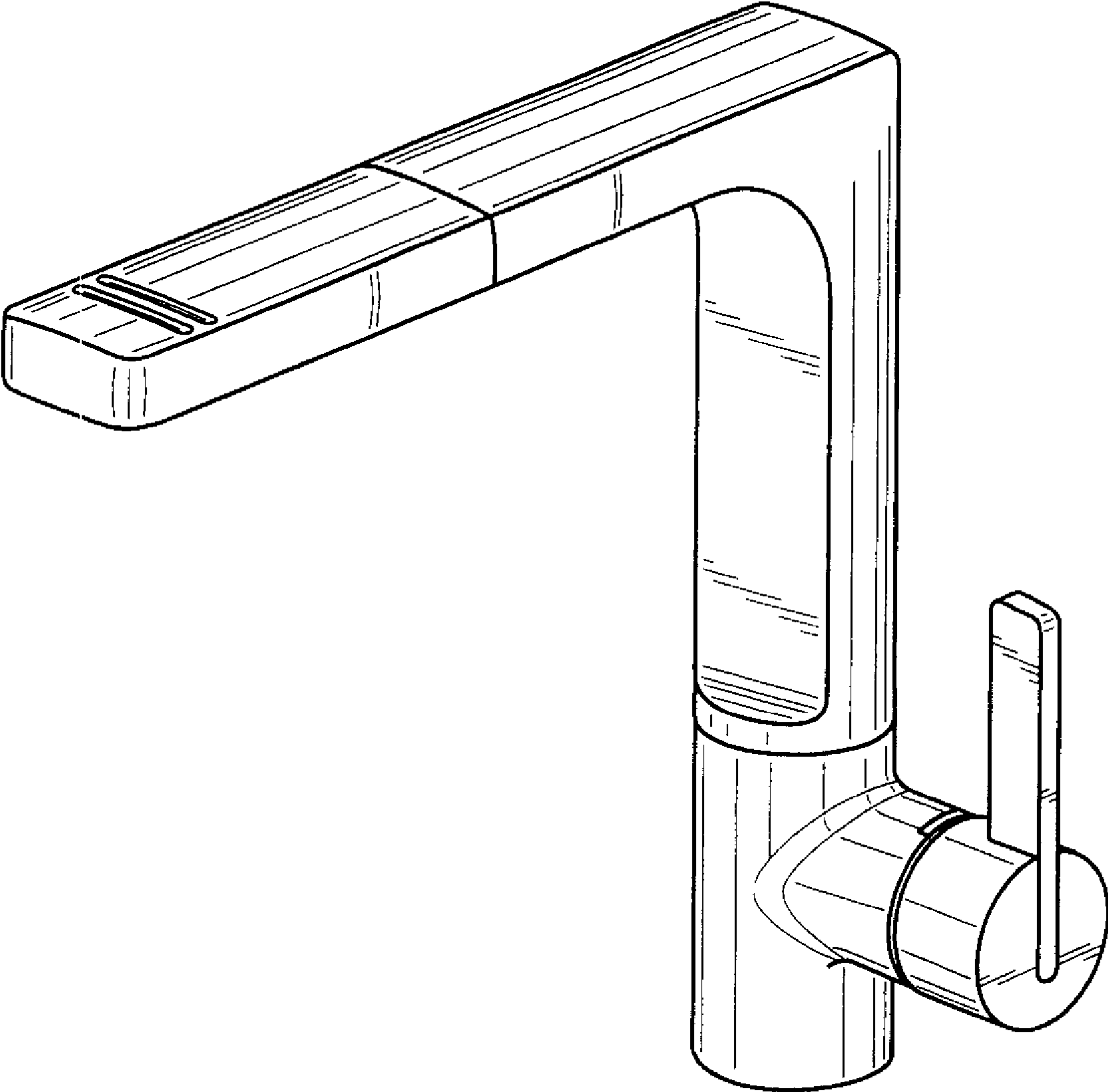

Fig. 1

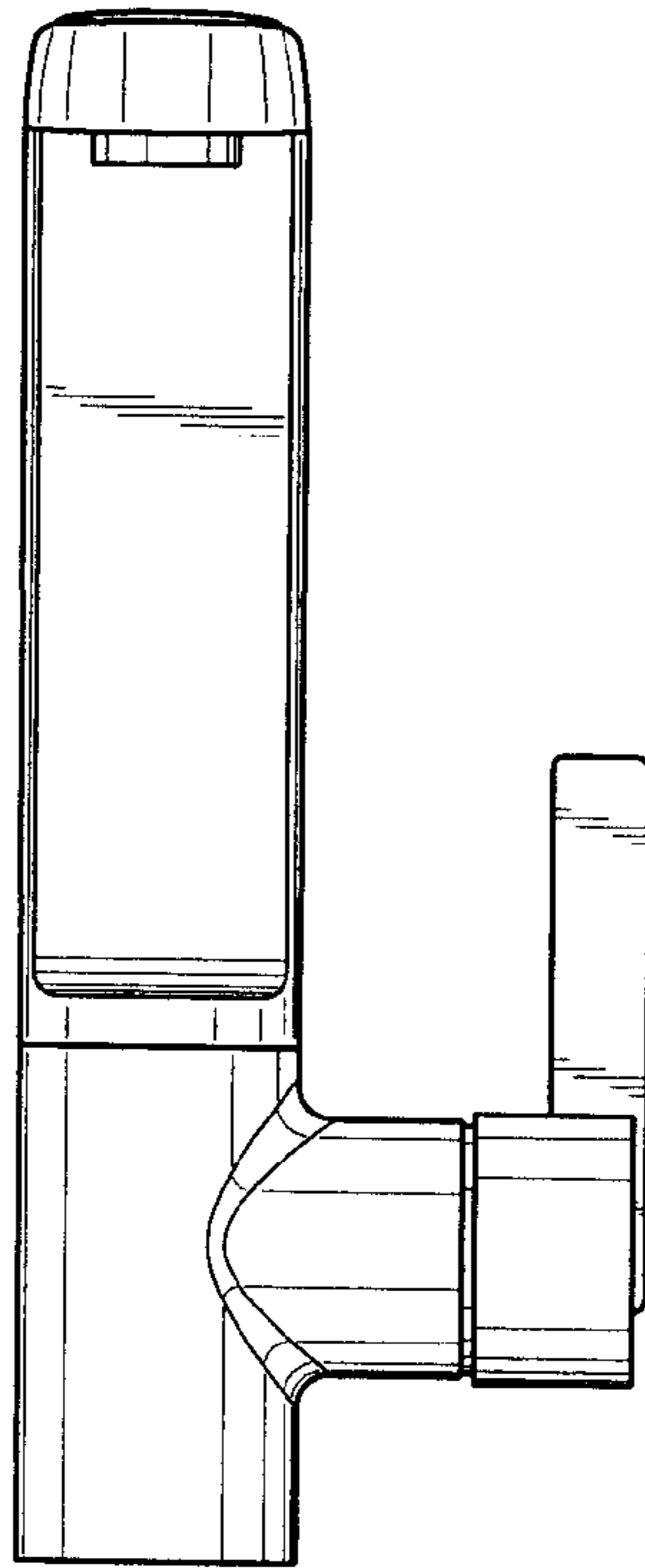

Fig. 2

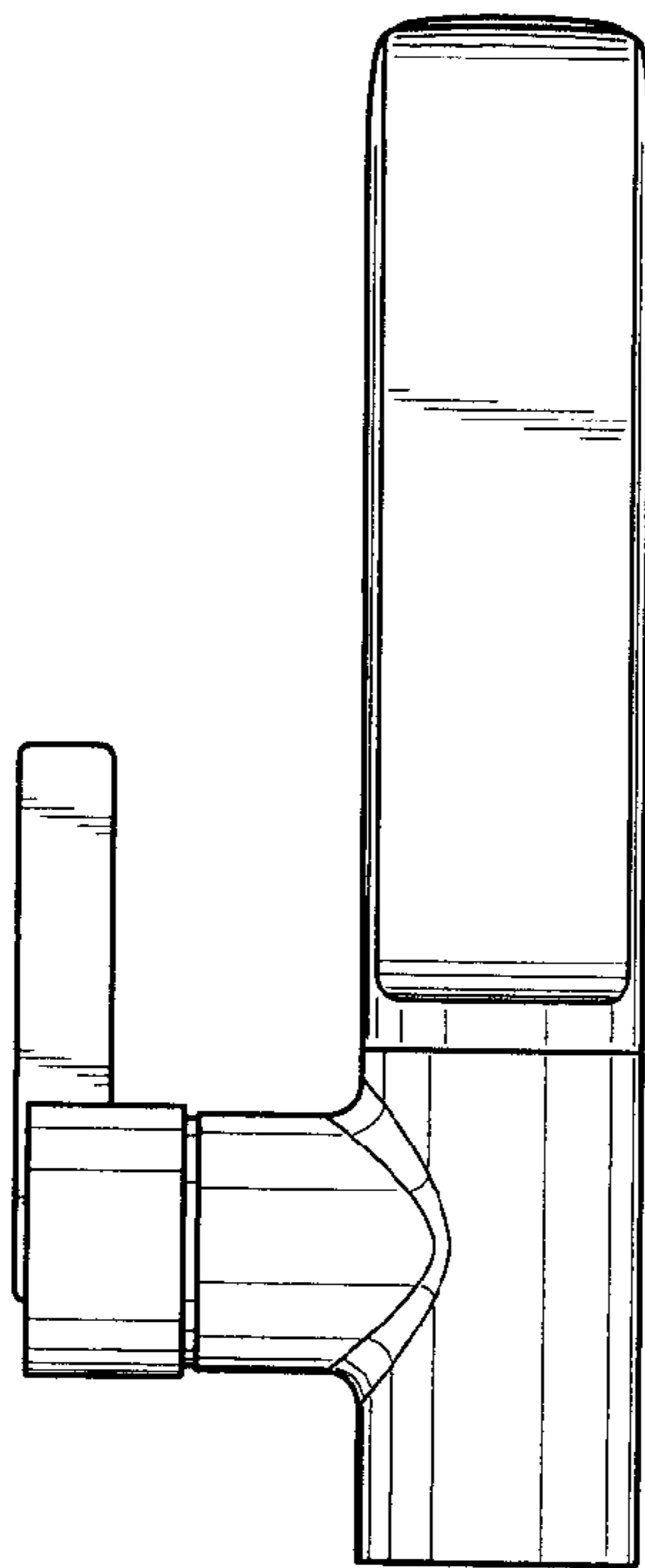

Fig. 3

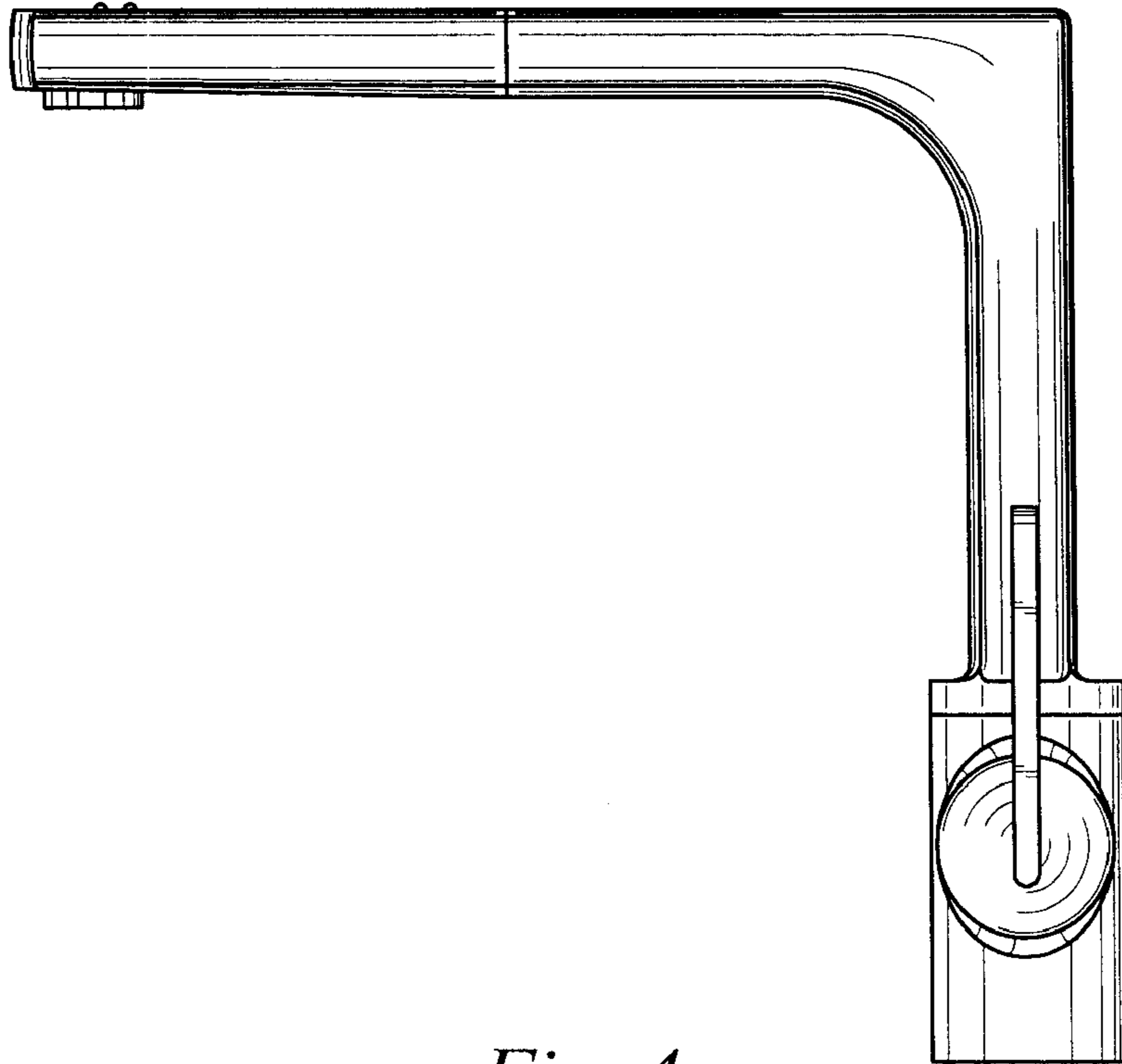

Fig. 4

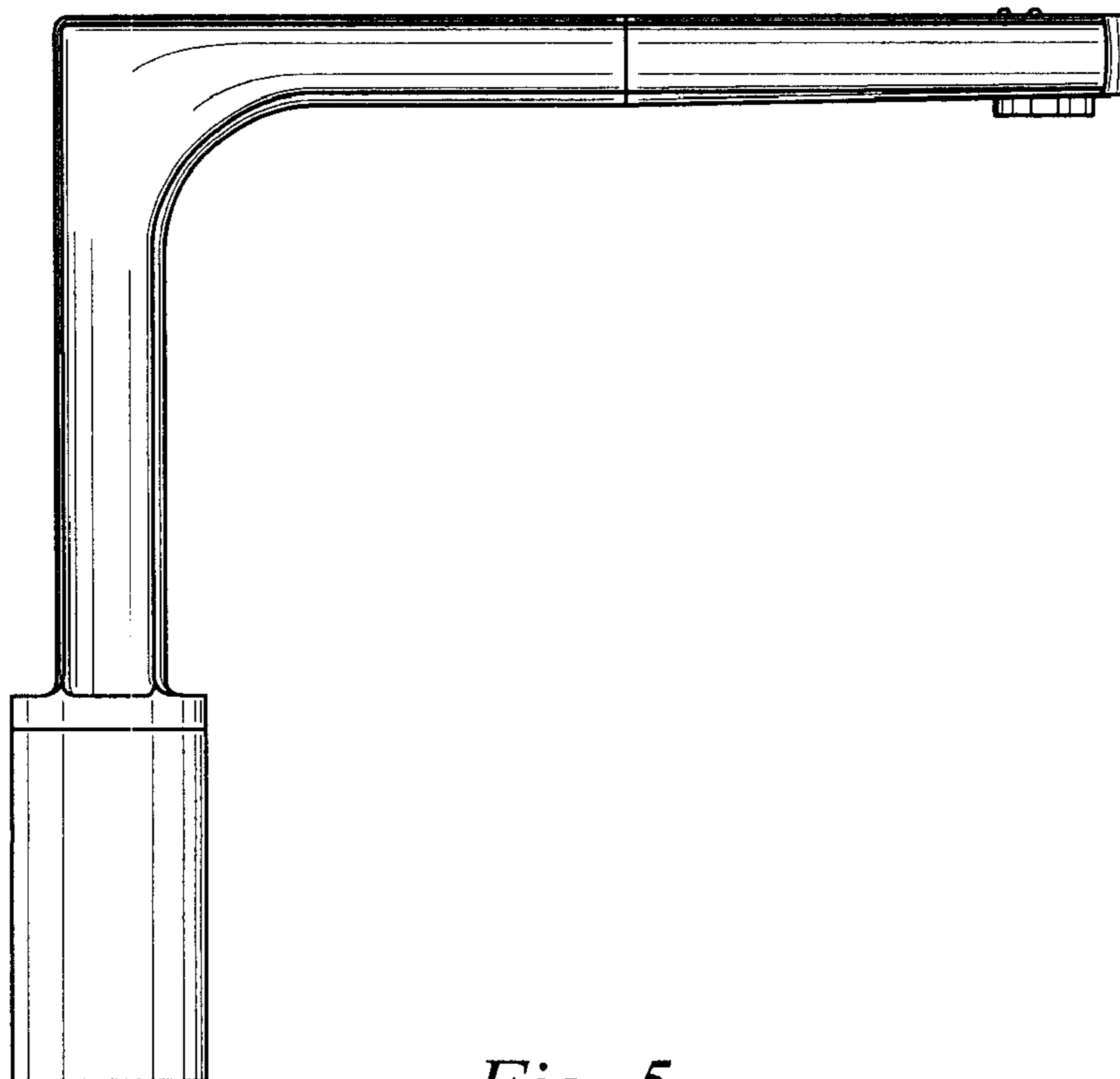

Fig. 5

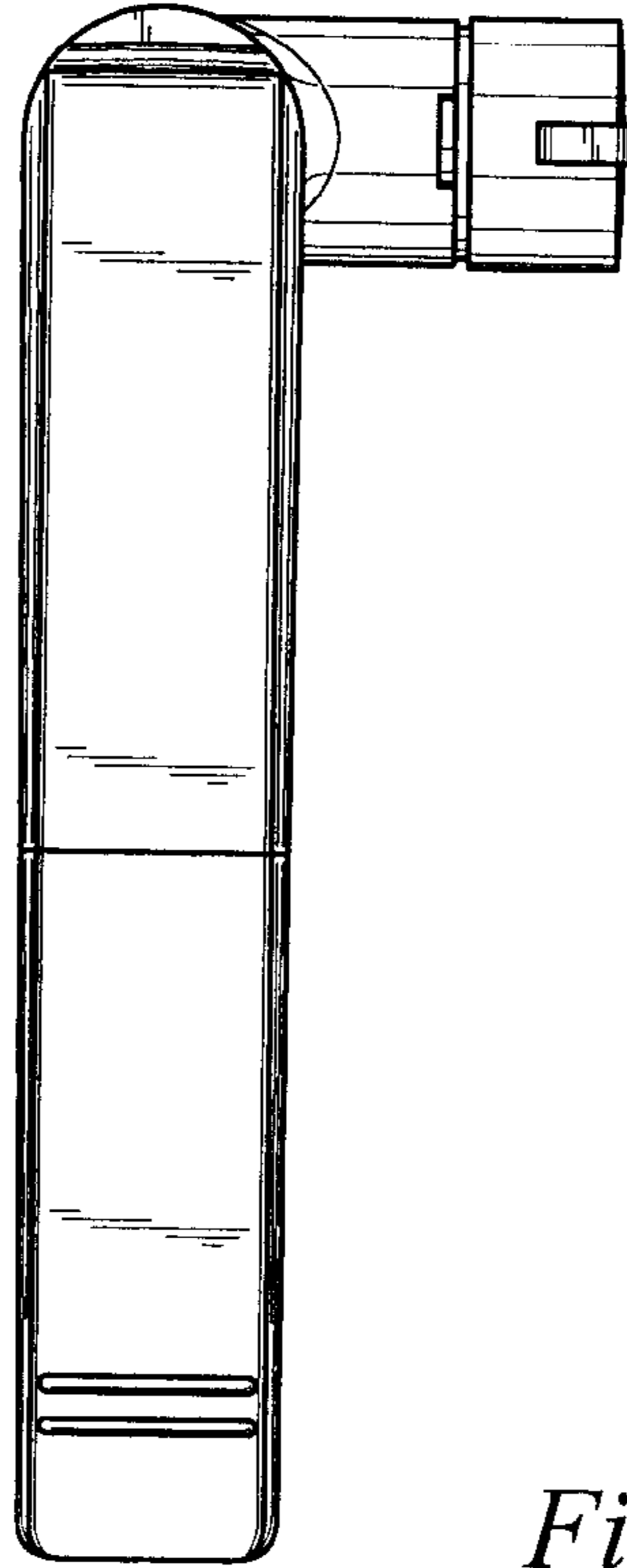

Fig. 6

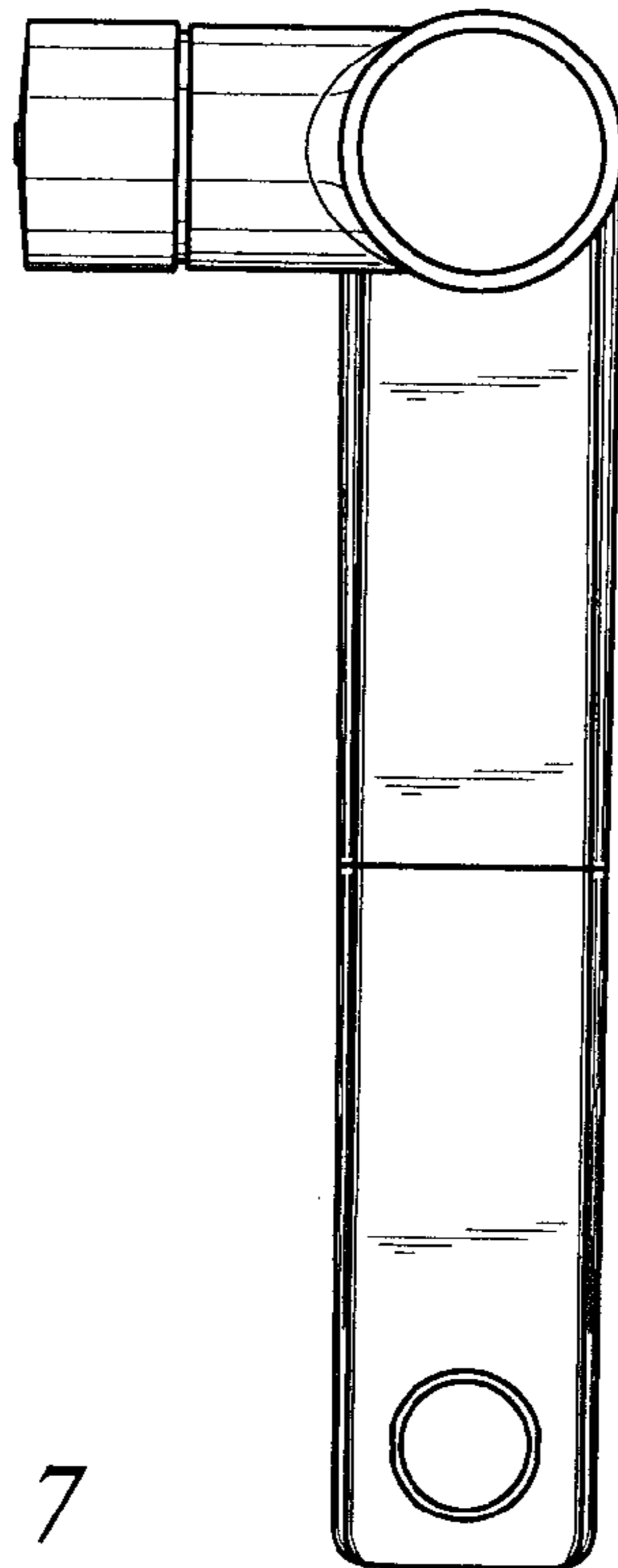

Fig. 7

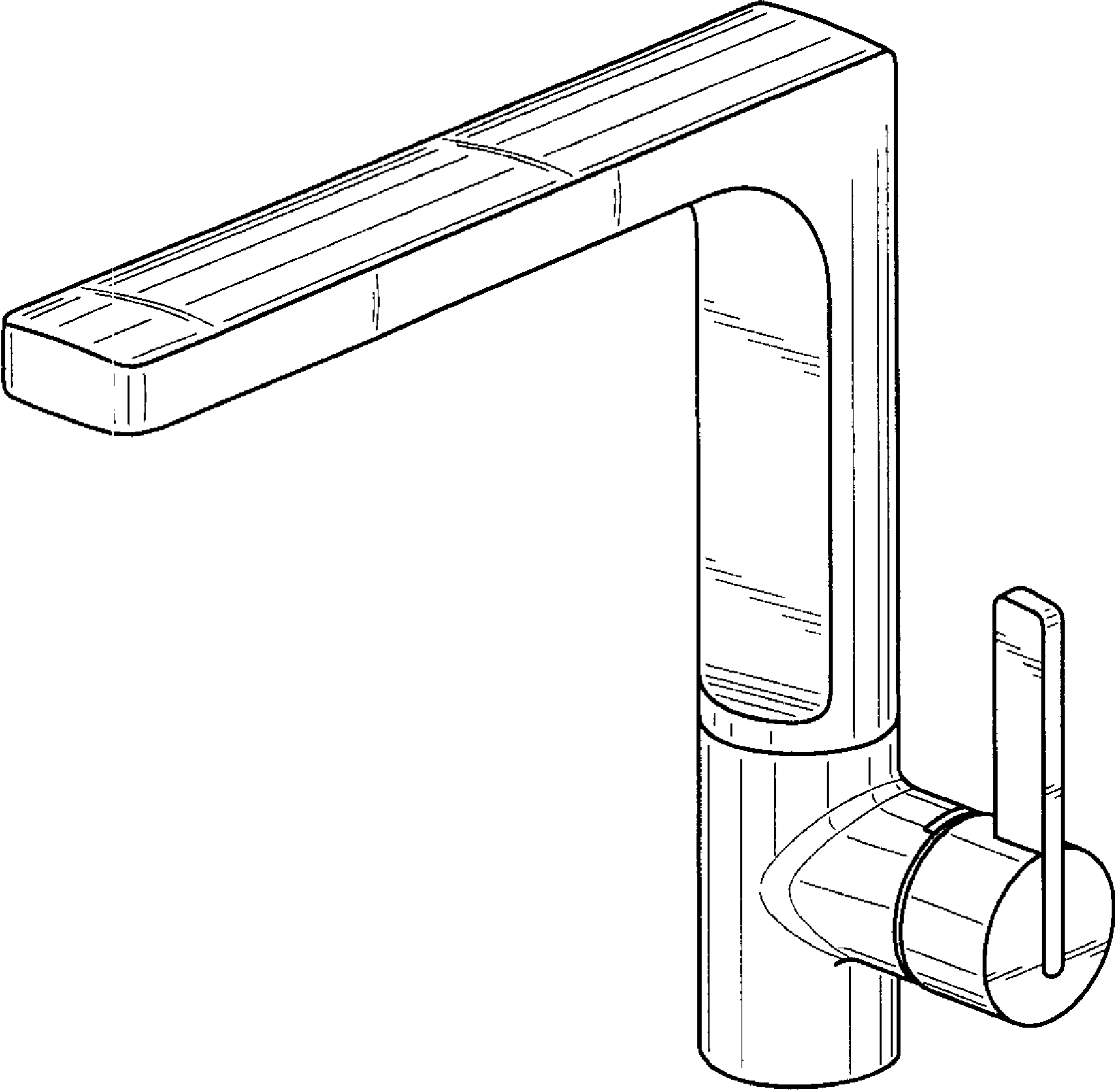

Fig. 8

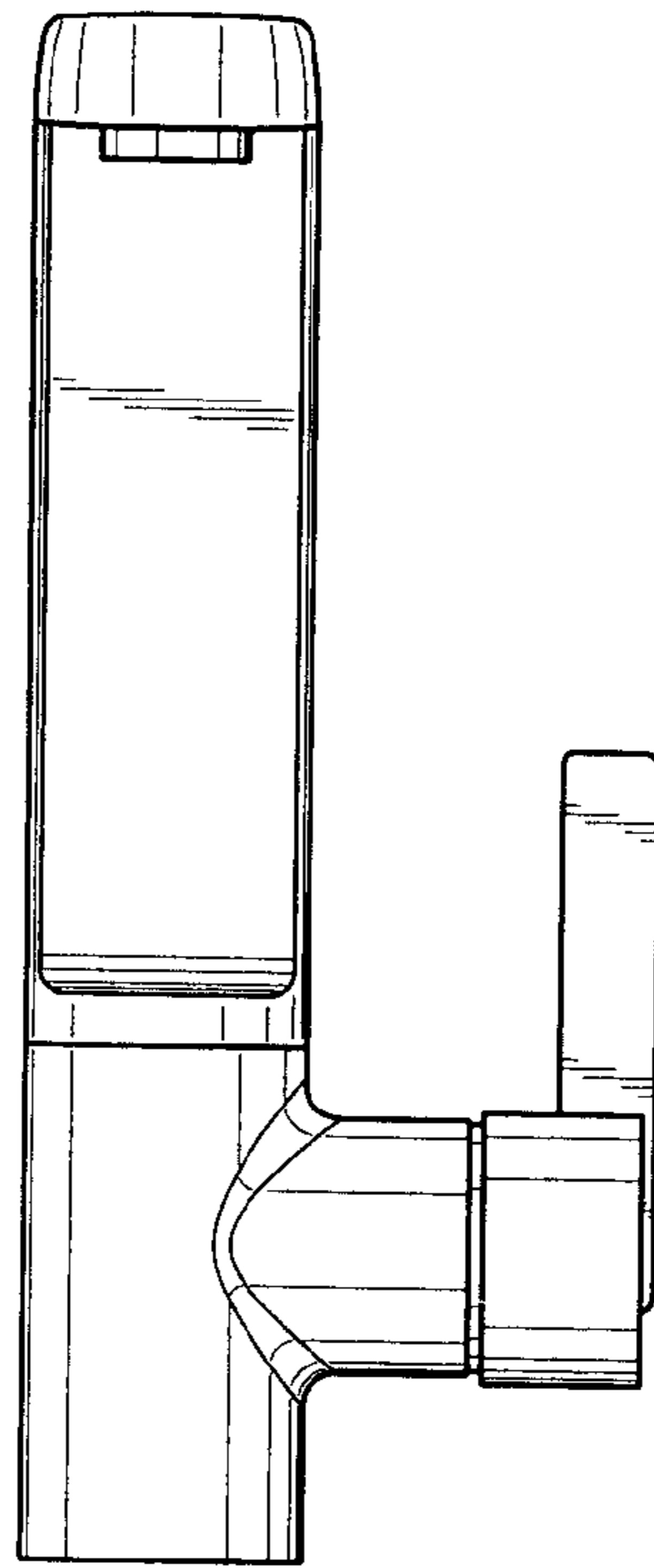

Fig. 9

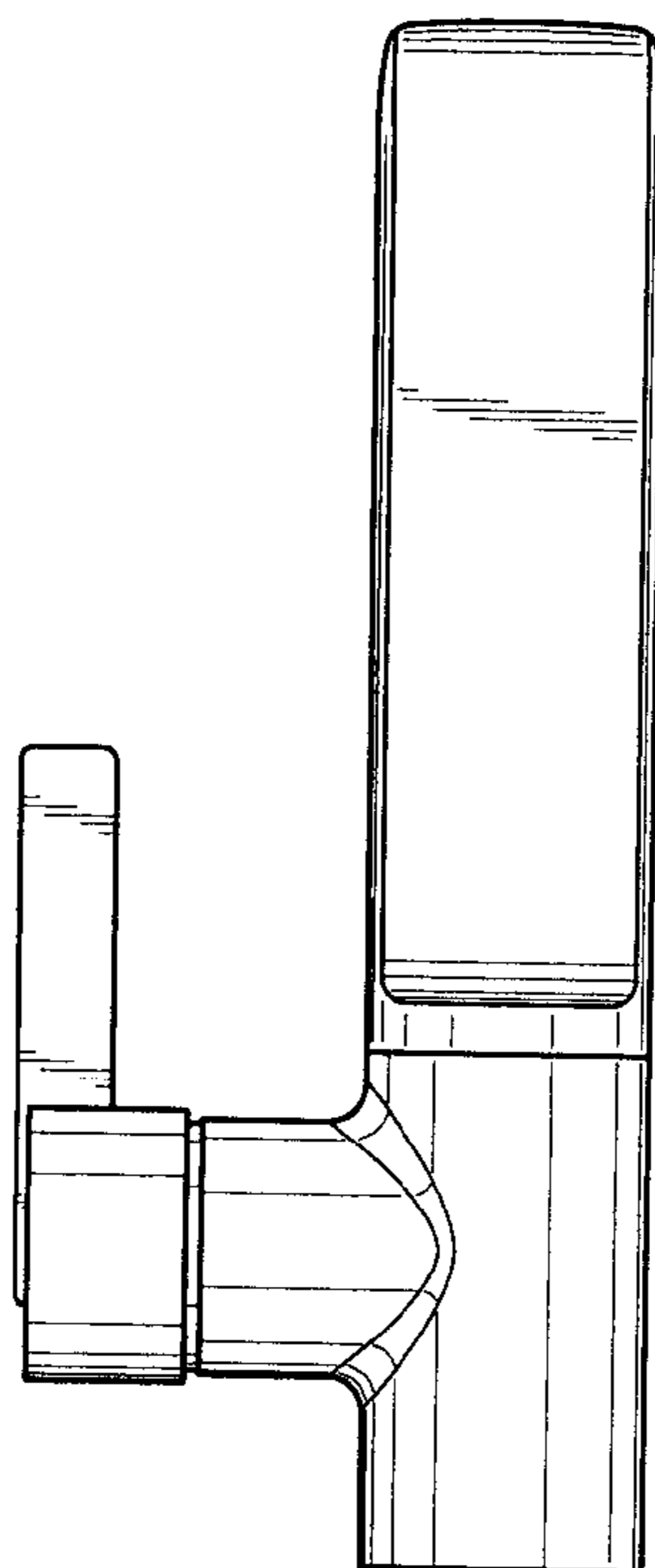

Fig. 10

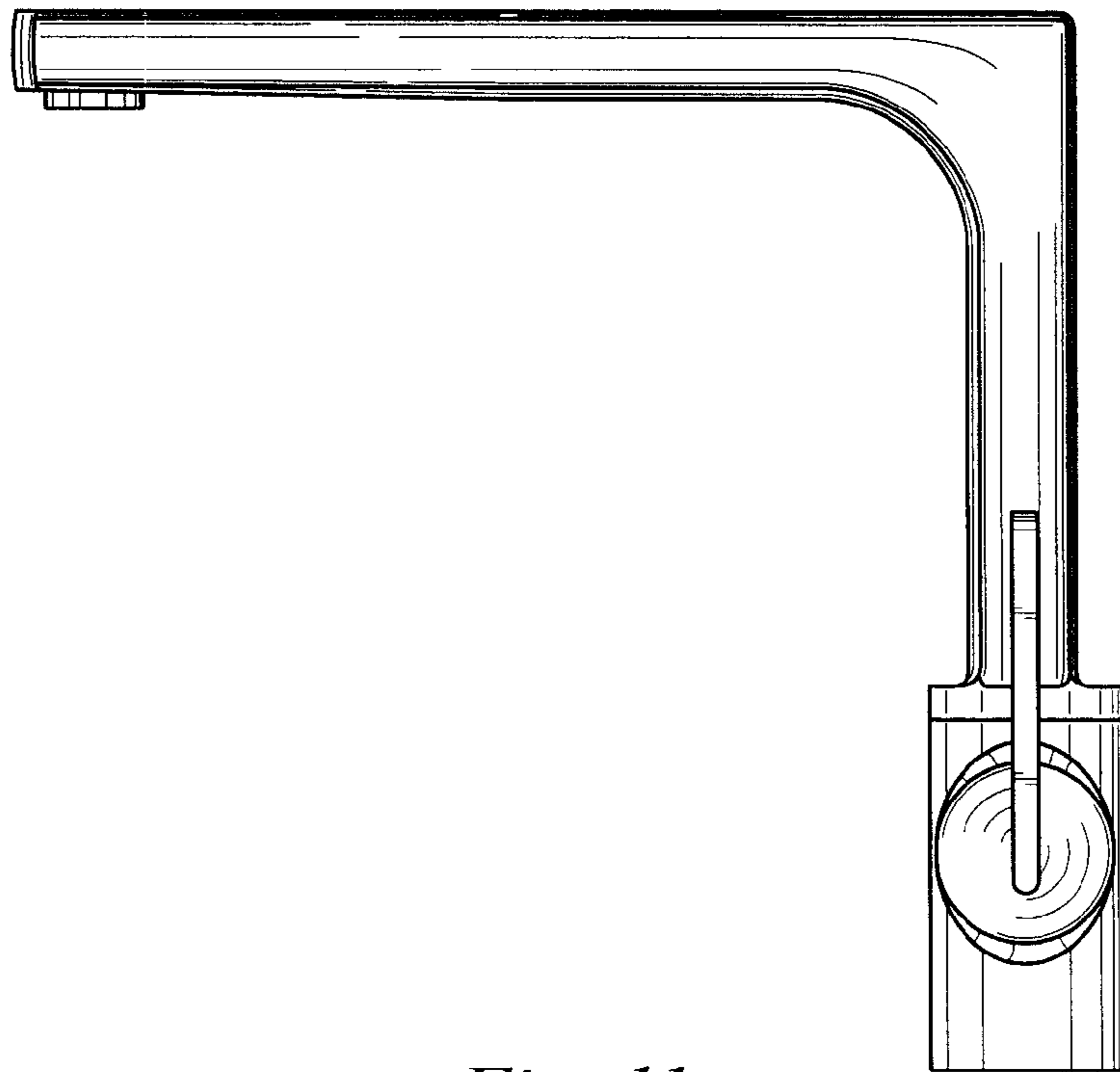

Fig. 11

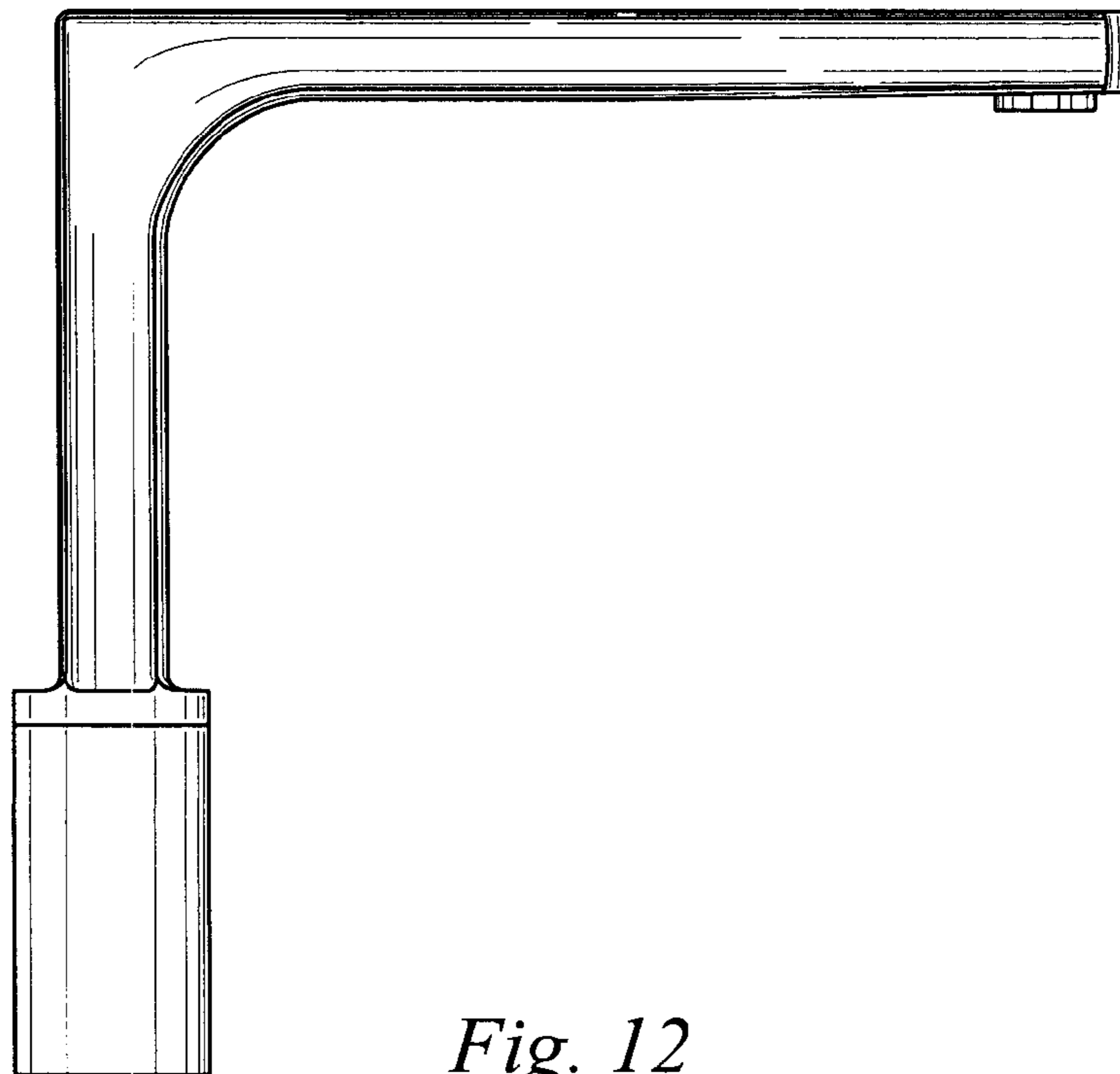

Fig. 12

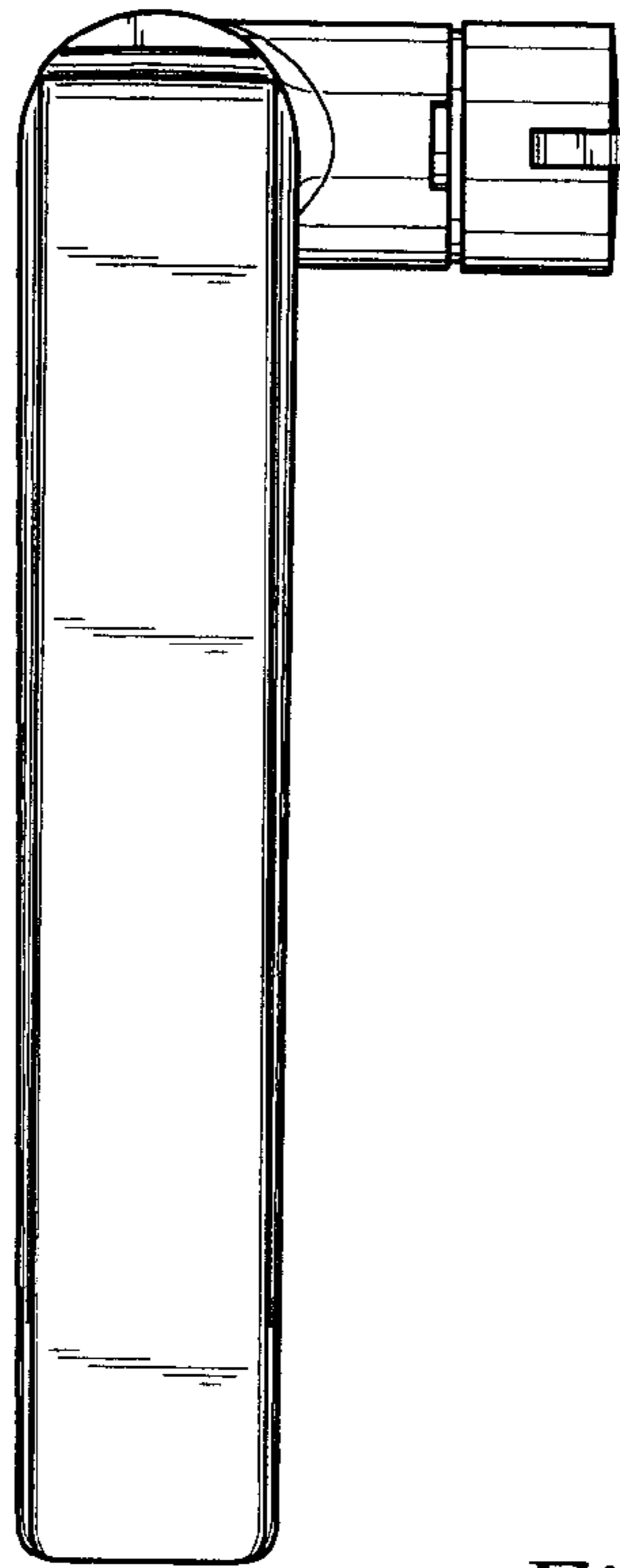

Fig. 13

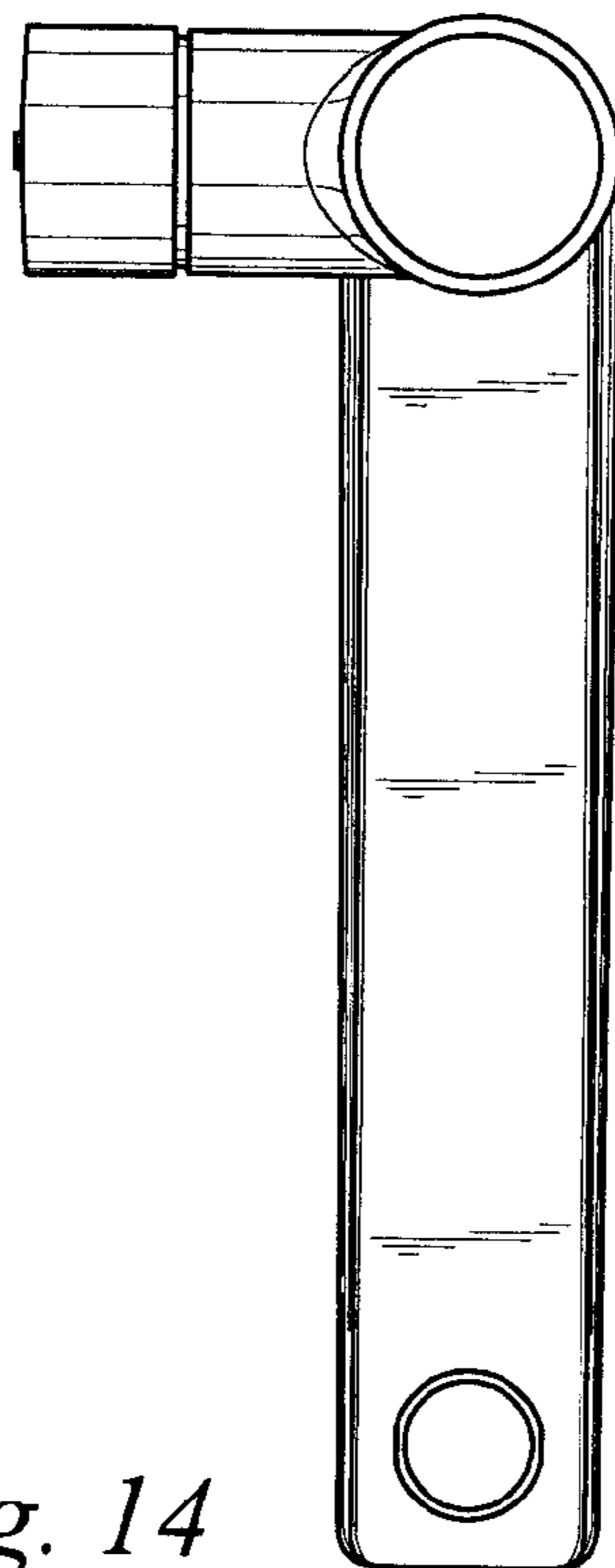

Fig. 14