



US00D534129S

(12) **United States Design Patent**
Park

(10) **Patent No.:** **US D534,129 S**

(45) **Date of Patent:** **** Dec. 26, 2006**

(54) **CONNECTOR OF THE TEMPERATURE
SENSOR FOR OVEN RANGE**

(75) Inventor: **James Ji-Hong Park**, Seoul (KR)

(73) Assignee: **James Tech Co., Ltd.** (KR)

(**) Term: **14 Years**

(21) Appl. No.: **29/240,817**

(22) Filed: **Oct. 19, 2005**

(30) **Foreign Application Priority Data**

Sep. 28, 2005 (KR) 30-2005-0032804

(51) **LOC (8) Cl.** **13-03**

(52) **U.S. Cl.** **D13/151**

(58) **Field of Classification Search** D13/133,
D13/151, 146-149, 154, 184; D23/386; 174/87,
174/74 R; 439/161, 259, 266, 270, 278, 374,
439/483-485, 527, 476.1, 519, 775, 784,
439/801, 892, 894

See application file for complete search history.

(56) **References Cited**

U.S. PATENT DOCUMENTS

- 3,437,982 A * 4/1969 O'Keefe et al. 439/578
- 3,711,632 A * 1/1973 Ghirardi 174/135
- D259,636 S * 6/1981 Coppell D13/151
- D314,814 S * 2/1991 Lubeck D23/262

- 5,098,310 A * 3/1992 Avramovich et al. 439/282
- D341,126 S * 11/1993 Finamore et al. D13/151
- 6,106,304 A * 8/2000 Huang 439/63
- 6,109,953 A * 8/2000 Hashigaya et al. 439/457
- D469,742 S * 2/2003 Michon et al. D13/151
- 6,726,510 B1 * 4/2004 Norbert et al. 439/810
- D495,662 S * 9/2004 Chawgo D13/156
- D501,649 S * 2/2005 Yang et al. D13/133
- D510,910 S * 10/2005 Chung D13/154

* cited by examiner

Primary Examiner—Prabhakar Deshmukh

Assistant Examiner—Daniel Bui

(74) *Attorney, Agent, or Firm*—Irving Keschner

(57) **CLAIM**

The ornamental design for a connector of the temperature sensor for oven range, as shown.

DESCRIPTION

FIG. 1 is a perspective view of a connector of the temperature sensor or oven range, showing my new invention; FIG. 2 is a front elevational view thereof; FIG. 3 is a rear elevational view thereof; FIG. 4 is a left side elevational view thereof; FIG. 5 is a right side elevational view thereof; FIG. 6 is a top plan view thereof; and FIG. 7 is a bottom view thereof.

1 Claim, 3 Drawing Sheets

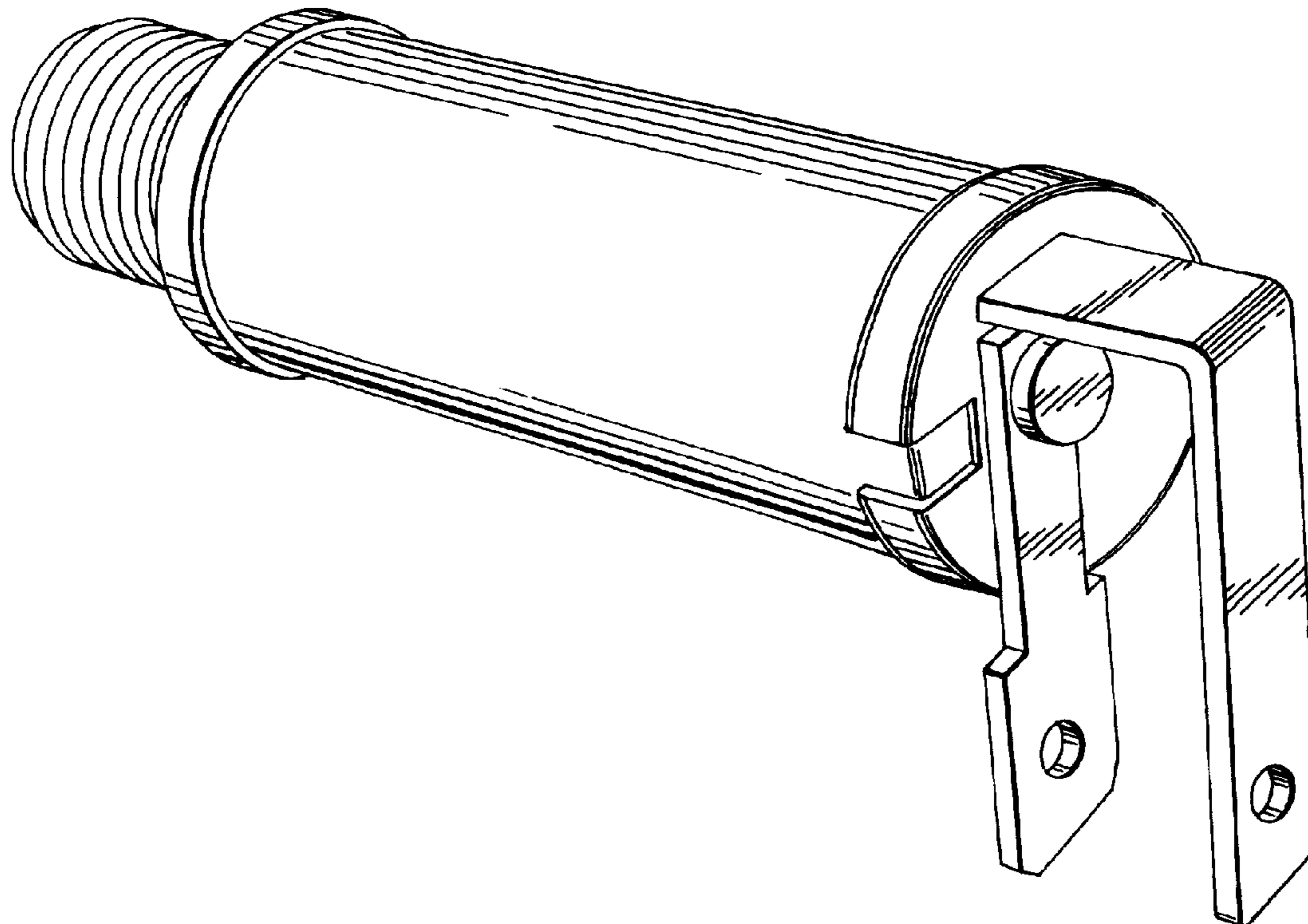

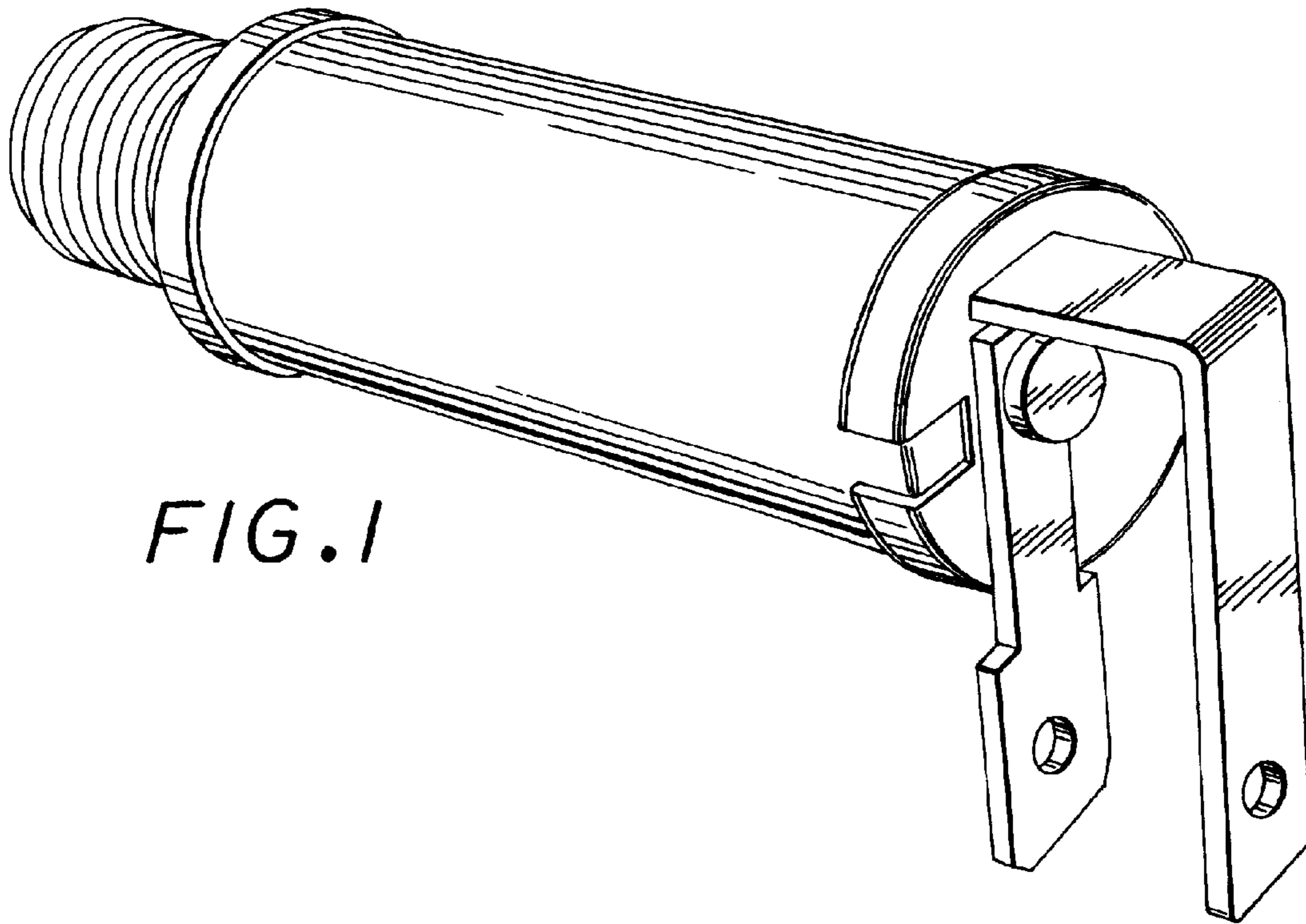

FIG. 1

FIG. 2

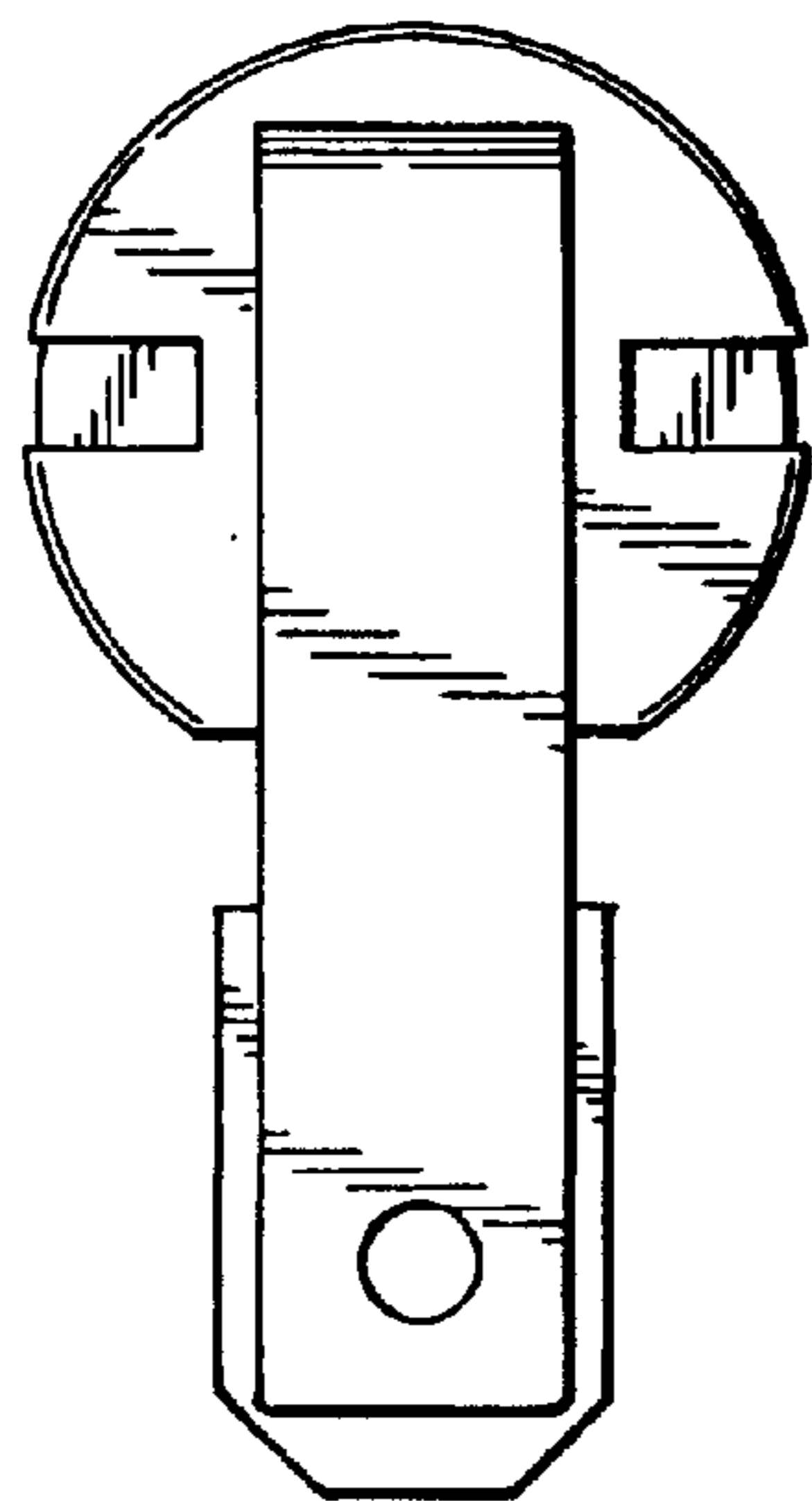

FIG. 3

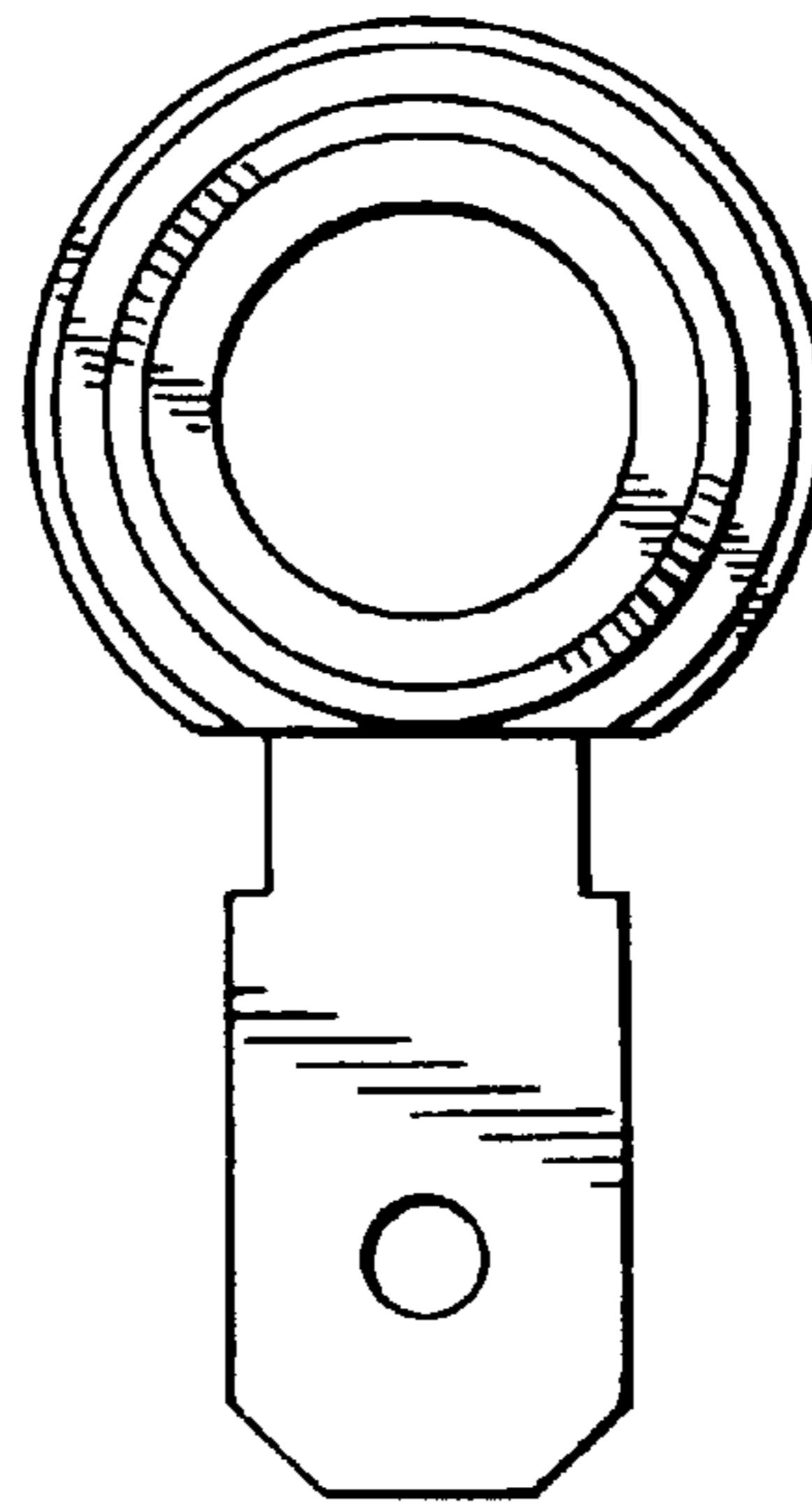

FIG. 4

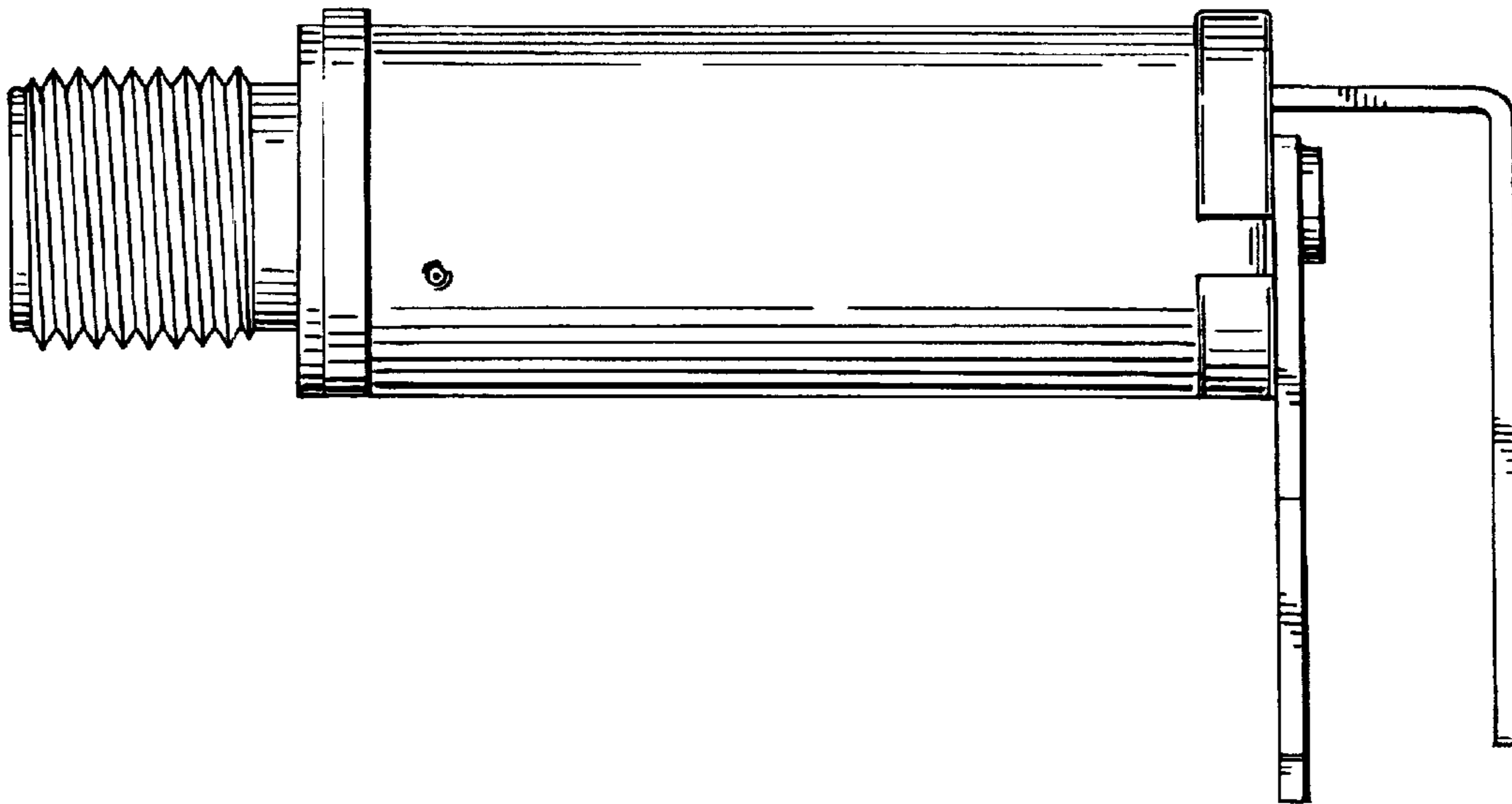

FIG. 5

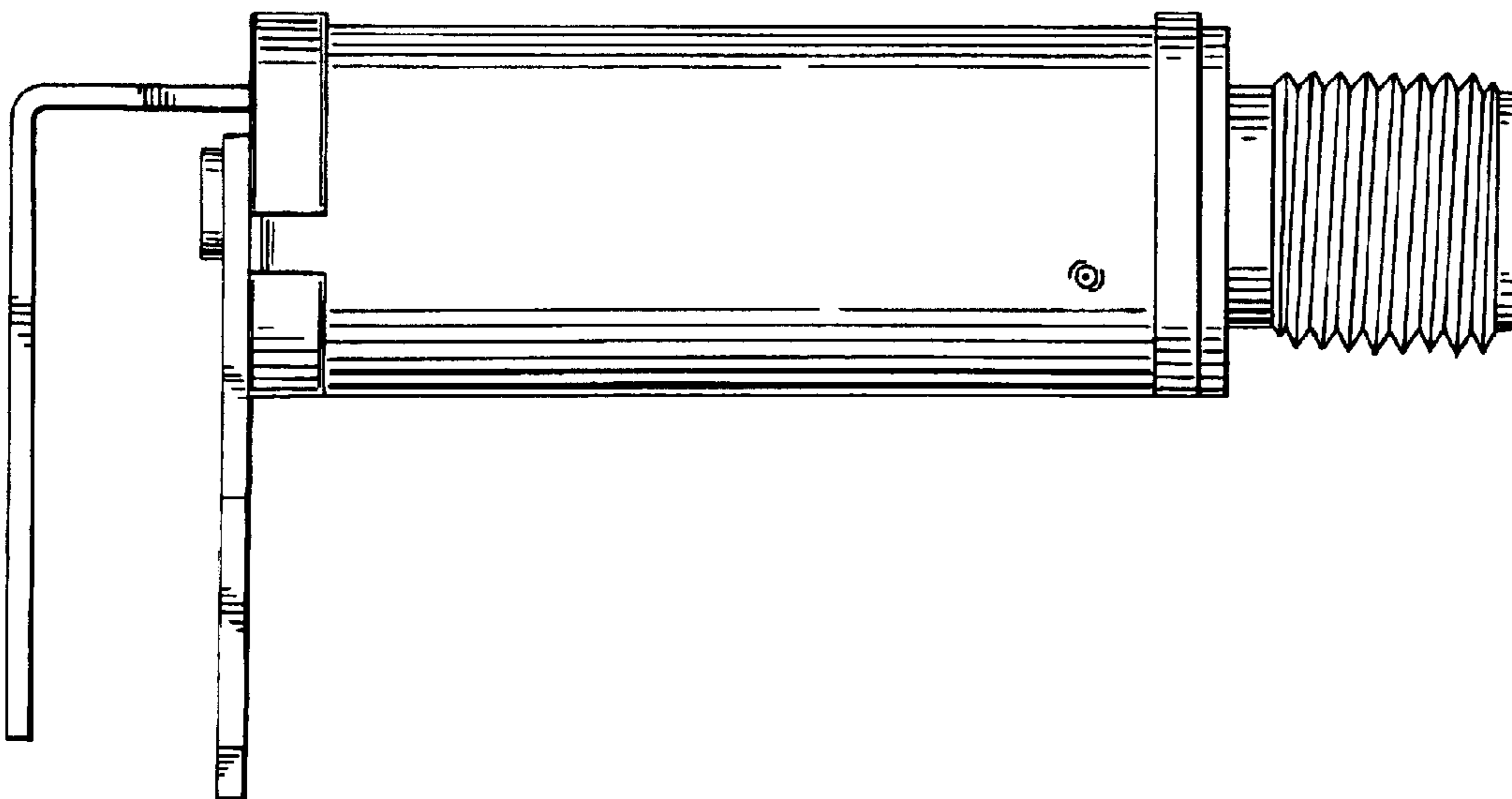

FIG. 6

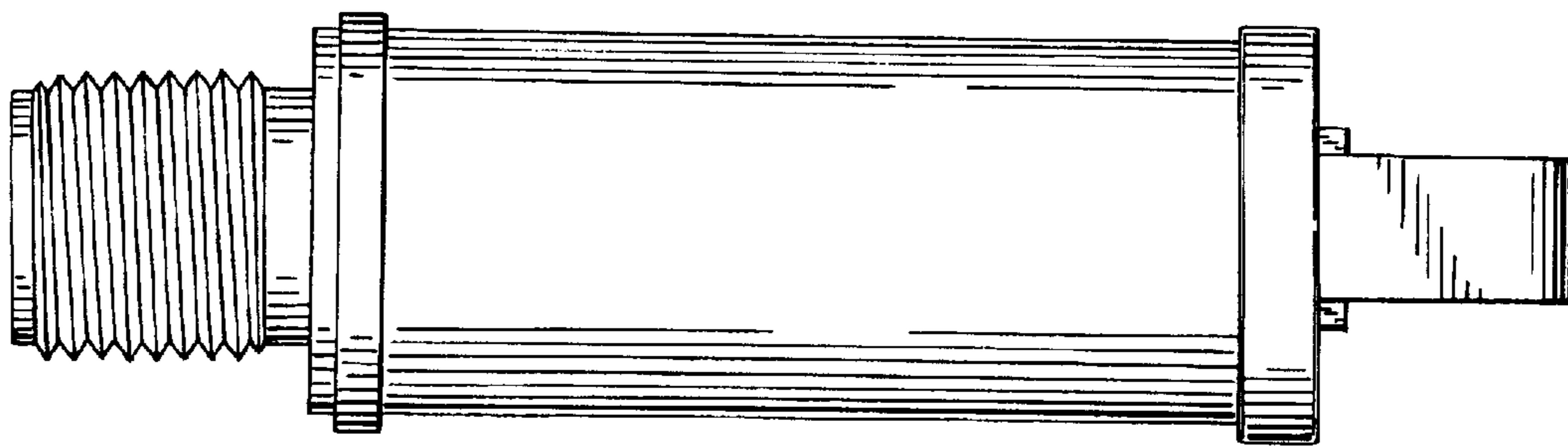

FIG. 7

