



US00D534097S

(12) **United States Design Patent**
Renkert et al.

(10) **Patent No.:** **US D534,097 S**

(45) **Date of Patent:** **** Dec. 26, 2006**

(54) **AUTOMOBILE BODY**

(75) Inventors: **Donald A Renkert**, Royal Oak, MI (US); **John P Sgalia**, Farmington Hills, MI (US); **Dan M Zimmermann**, Bloomfield Township, MI (US)

(73) Assignee: **DaimlerChrysler Corporation**, Auburn Hills, MI (US)

(**) Term: **14 Years**

(21) Appl. No.: **29/244,859**

(22) Filed: **Dec. 15, 2005**

(51) **LOC (8) Cl.** **12-08**

(52) **U.S. Cl.** **D12/91**

(58) **Field of Classification Search** D12/90-92, D12/86, 88; D21/424, 433; 296/181.1, 181.5
See application file for complete search history.

(56) **References Cited**

U.S. PATENT DOCUMENTS

D350,504 S	9/1994	Nixon
D416,519 S	11/1999	Won et al.
D420,939 S	2/2000	Faurote et al.
D424,992 S	5/2000	Faurote
D454,813 S	3/2002	Boniface et al.
D476,268 S	6/2003	Castiglione et al.

D497,572 S	*	10/2004	Widmann et al.	D12/91
D500,460 S		1/2005	Allen et al.	
D500,466 S	*	1/2005	Elwell et al.	D12/163
D506,955 S		7/2005	Allen et al.	
D507,766 S	*	7/2005	McMahan et al.	D12/91
D508,441 S	*	8/2005	Moushegian et al.	D12/91
D514,983 S	*	2/2006	Renkert et al.	D12/91

* cited by examiner

Primary Examiner—Melody N. Brown

(74) *Attorney, Agent, or Firm*—Ralph E. Smith

(57) **CLAIM**

The ornamental design for an automobile body, as shown and described.

DESCRIPTION

FIG. 1 is a front perspective view of an automobile body showing our new design;
FIG. 2 is a side view thereof;
FIG. 3 is a front view thereof;
FIG. 4 is a rear view thereof;
FIG. 5 is a rear perspective view thereof; and,
FIG. 6 is a top plan view thereof.

It will be understood that the broken lines presented in the drawings are for illustration only, and do not form a part of the claimed design.

1 Claim, 5 Drawing Sheets

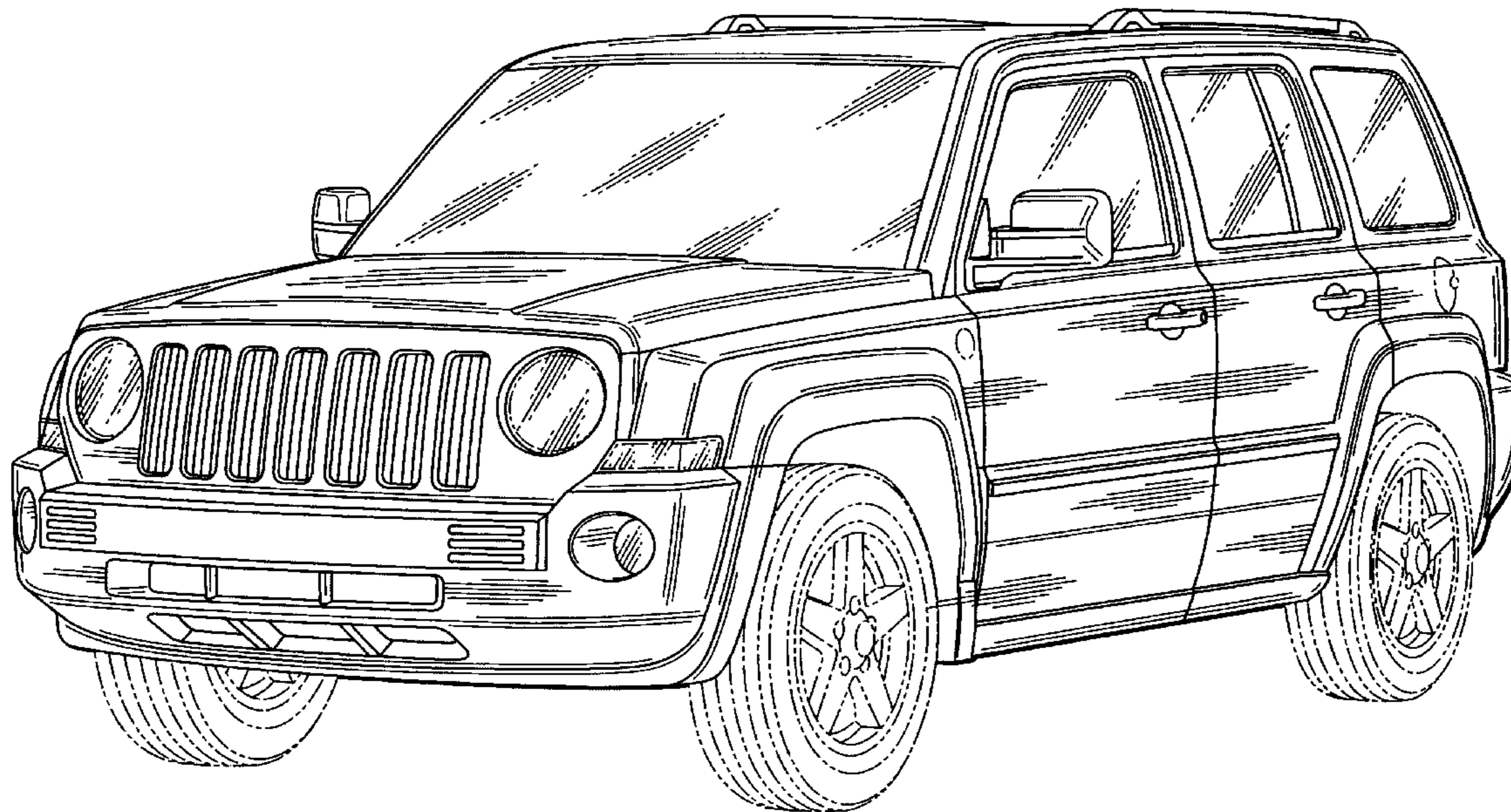

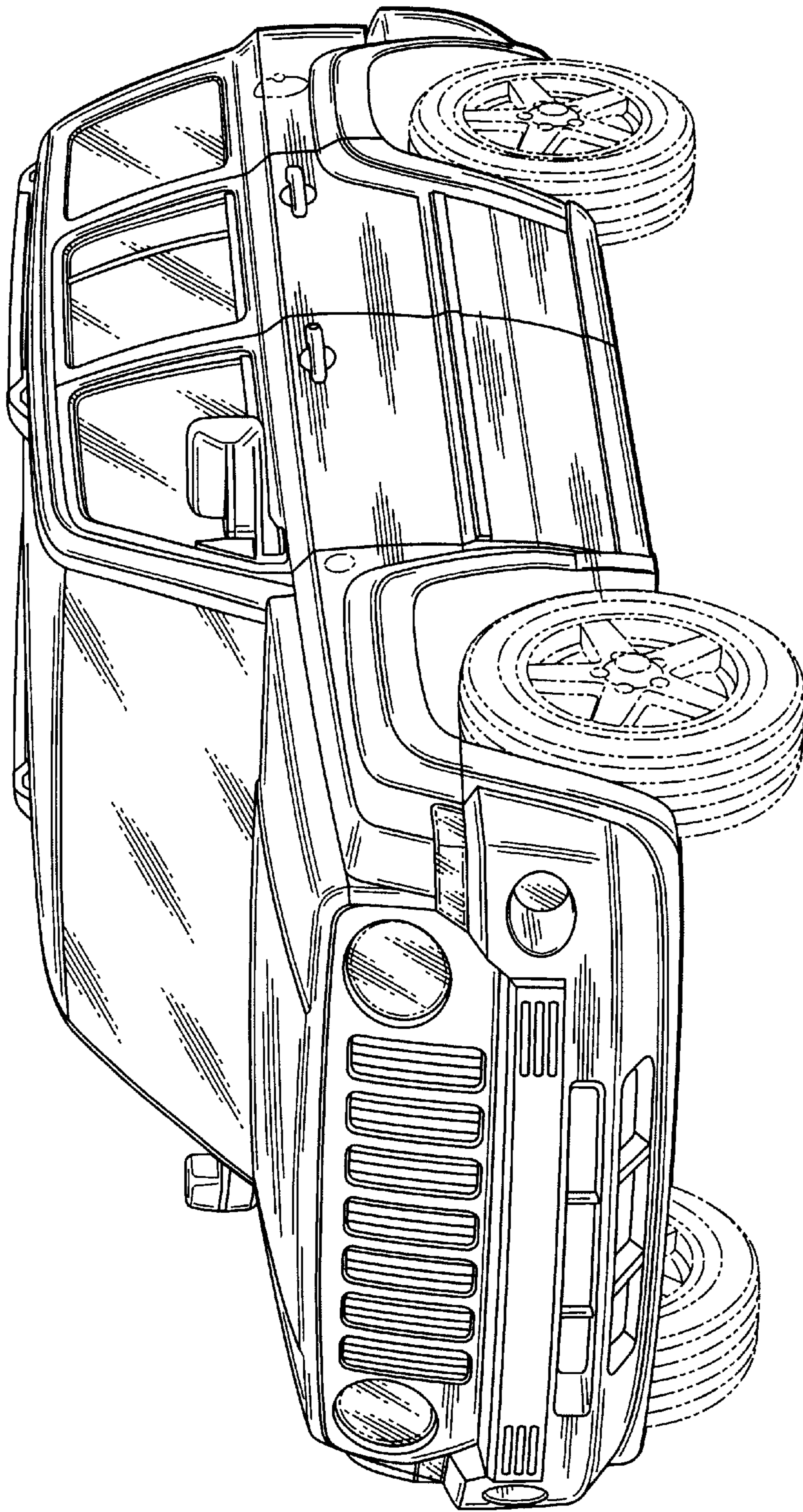

Fig. 1

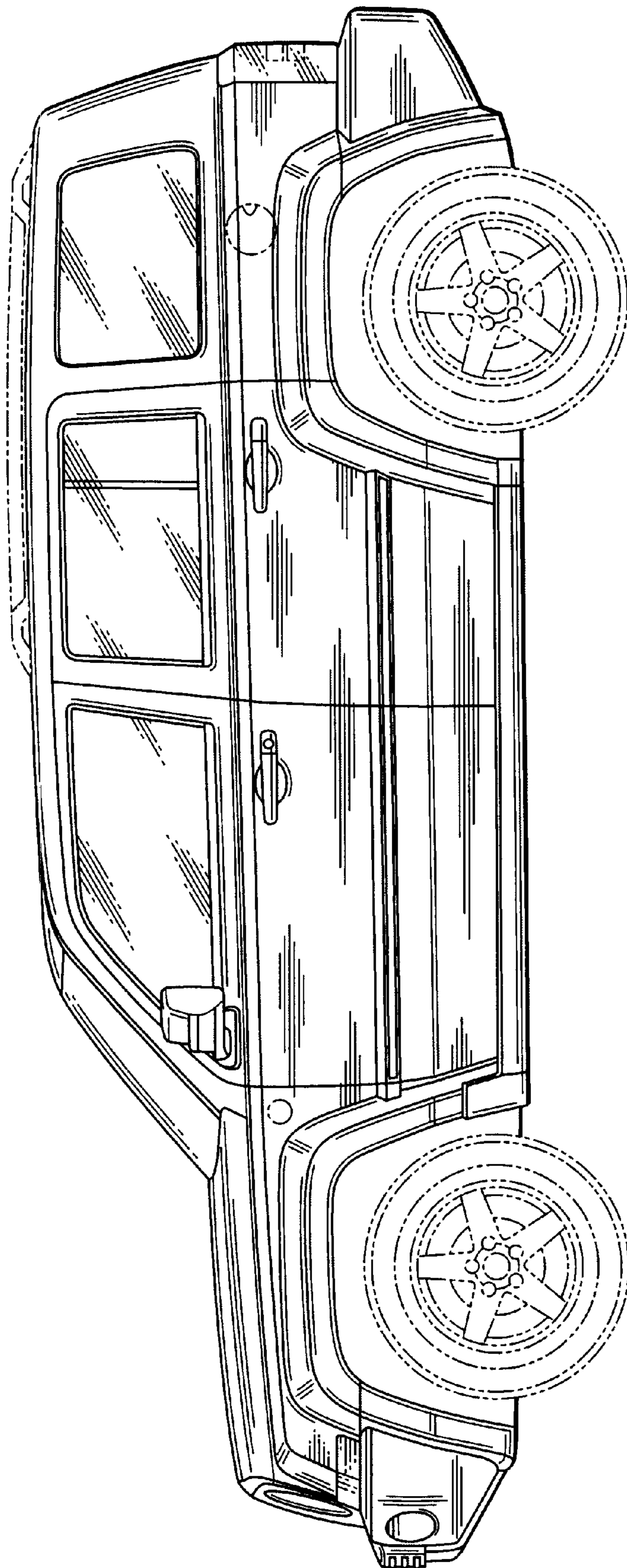

Fig. 2

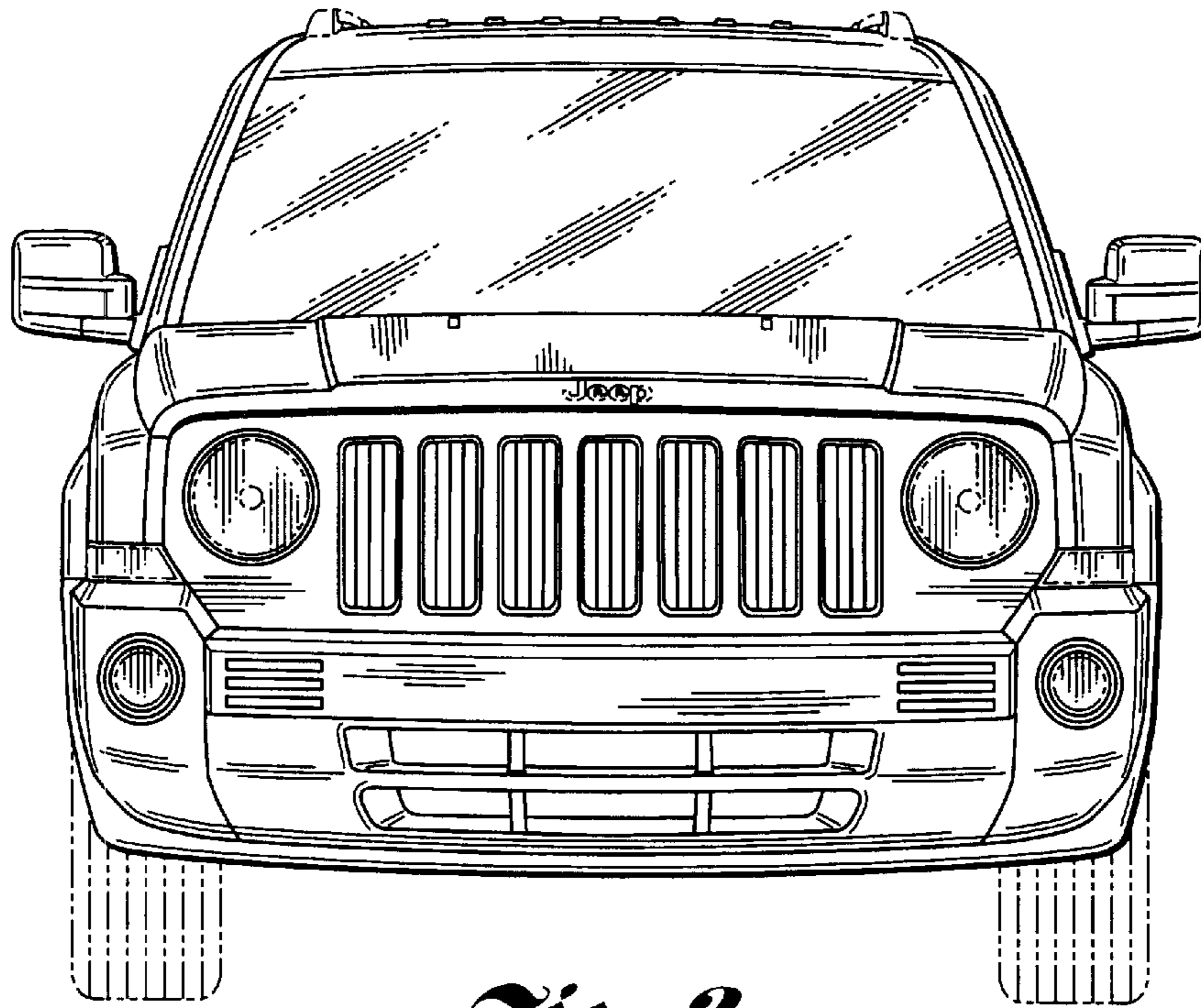

Fig. 3

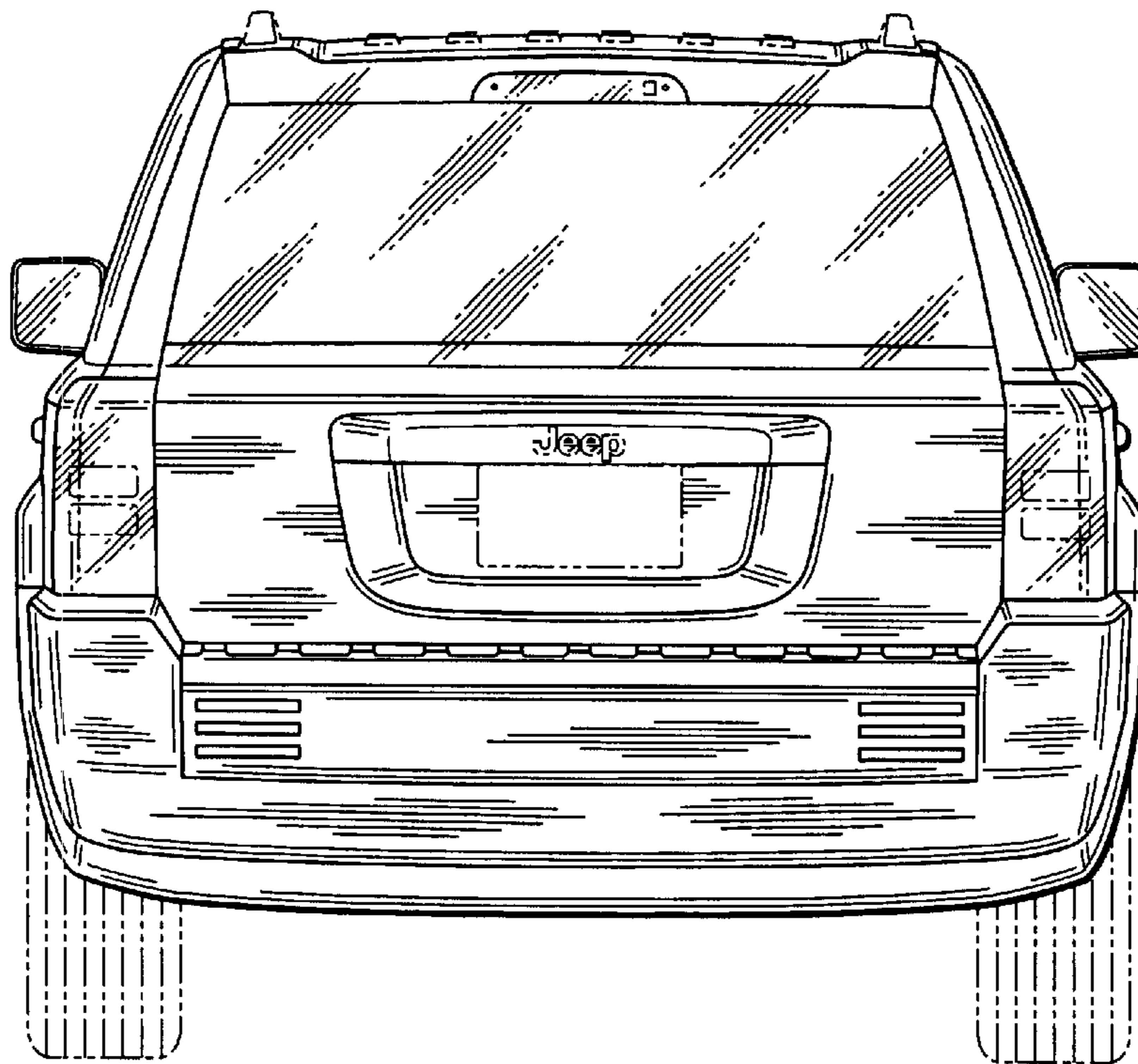

Fig. 4

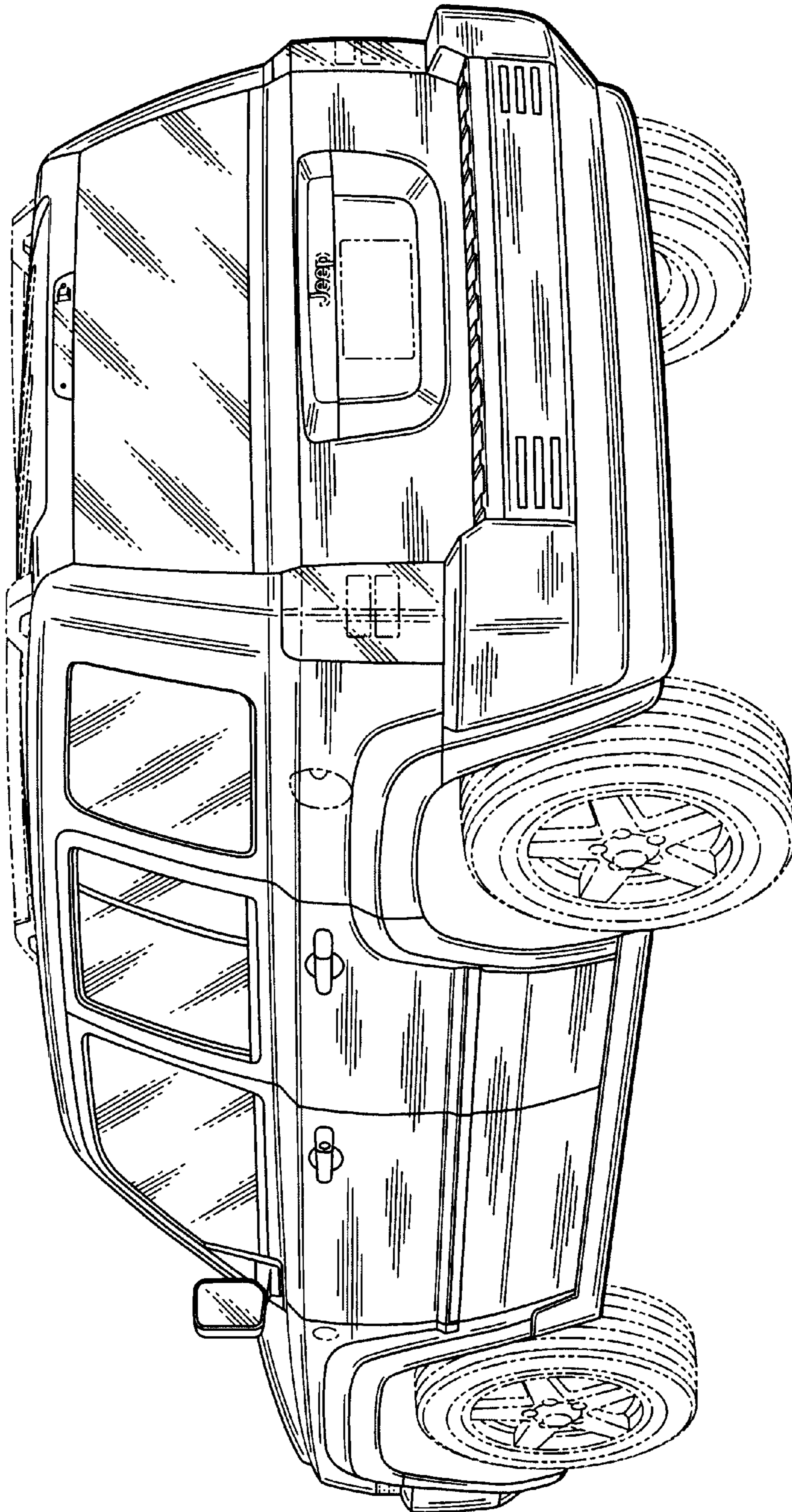

Fig. 5

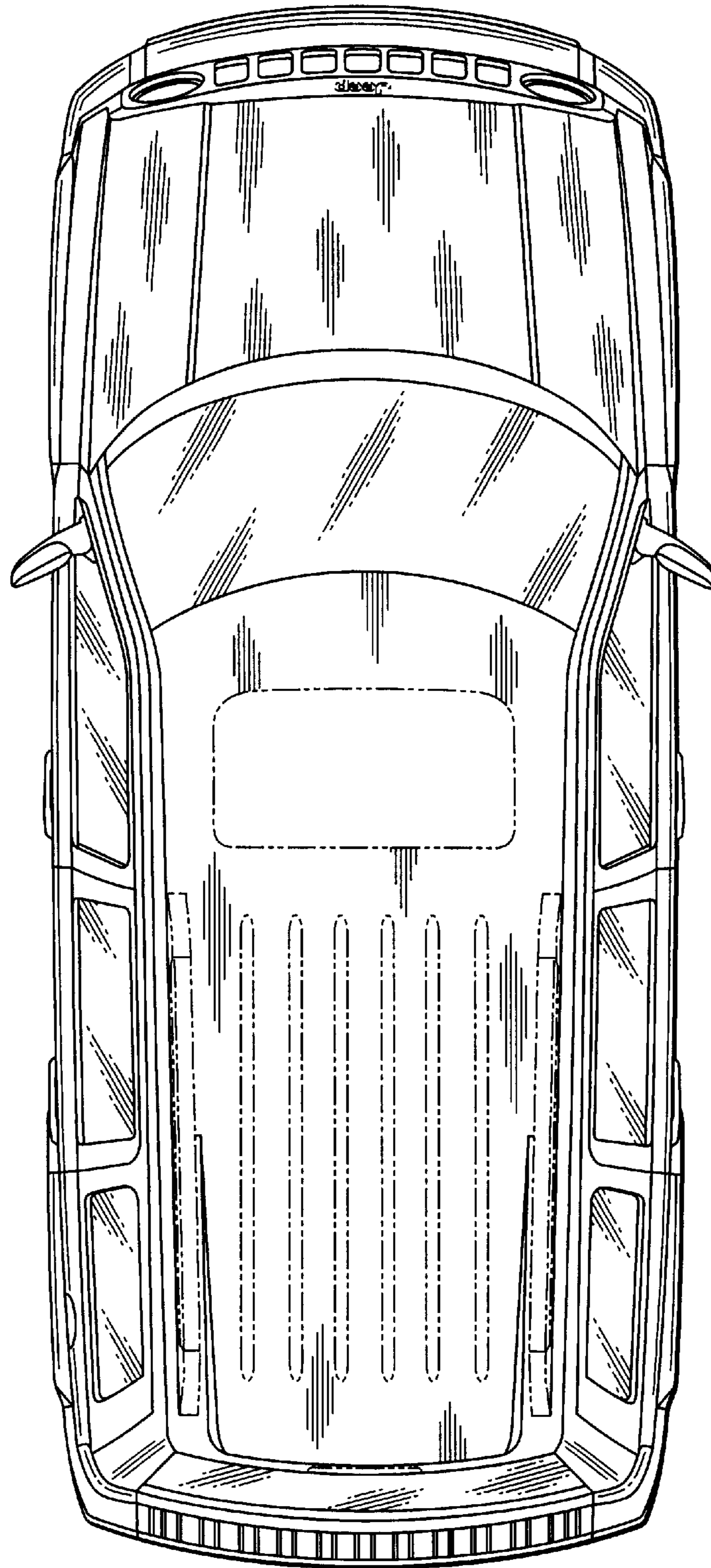

Fig. 6