



US00D533995S

(12) **United States Design Patent**
Booth

(10) **Patent No.:** **US D533,995 S**

(45) **Date of Patent:** **** Dec. 26, 2006**

(54) **BELT HAVING POUCHES FOR DIAPERS OR THE LIKE**

D490,239 S * 5/2004 Wagner, II D3/226
D497,715 S * 11/2004 Saltarelli D3/226

(75) Inventor: **Julia Booth**, New South Wales (AU)

* cited by examiner

(73) Assignee: **Mummita Pty Ltd**, South Wales (AU)

Primary Examiner—Catherine R. Oliver

(**) Term: **14 Years**

(57) **CLAIM**

(21) Appl. No.: **29/240,202**

The ornamental design for a belt having pouches for diapers or the like, as shown and described.

(22) Filed: **Oct. 6, 2005**

DESCRIPTION

(30) **Foreign Application Priority Data**

Apr. 11, 2005 (AU) 11457/2005

(51) **LOC (8) Cl.** **03-01**

(52) **U.S. Cl.** **D3/224**

(58) **Field of Classification Search** D3/224,
D3/226, 228; 224/901, 904, 684, 245, 240,
224/250, 661

FIG. 1 is a perspective view of the belt having pouches for diapers or the like showing my new design, with the pouches shown closed;

FIG. 2 is a left side view of the invention, with the pouches closed;

FIG. 3 is a front view of the invention with the pouches closed;

FIG. 4 is a rear view of the invention with the pouches closed;

See application file for complete search history.

FIG. 5 is front view of the invention with the pouches open; and,

FIG. 6 is a top view of the invention with the pouches open and illustrating a pair of internal zippered pockets in one of the pouches.

(56) **References Cited**

U.S. PATENT DOCUMENTS

D334,663 S * 4/1993 Petrillo D3/226

D360,295 S * 7/1995 Myatt D3/224

D433,228 S * 11/2000 Wentling, Jr. D3/226

1 Claim, 3 Drawing Sheets

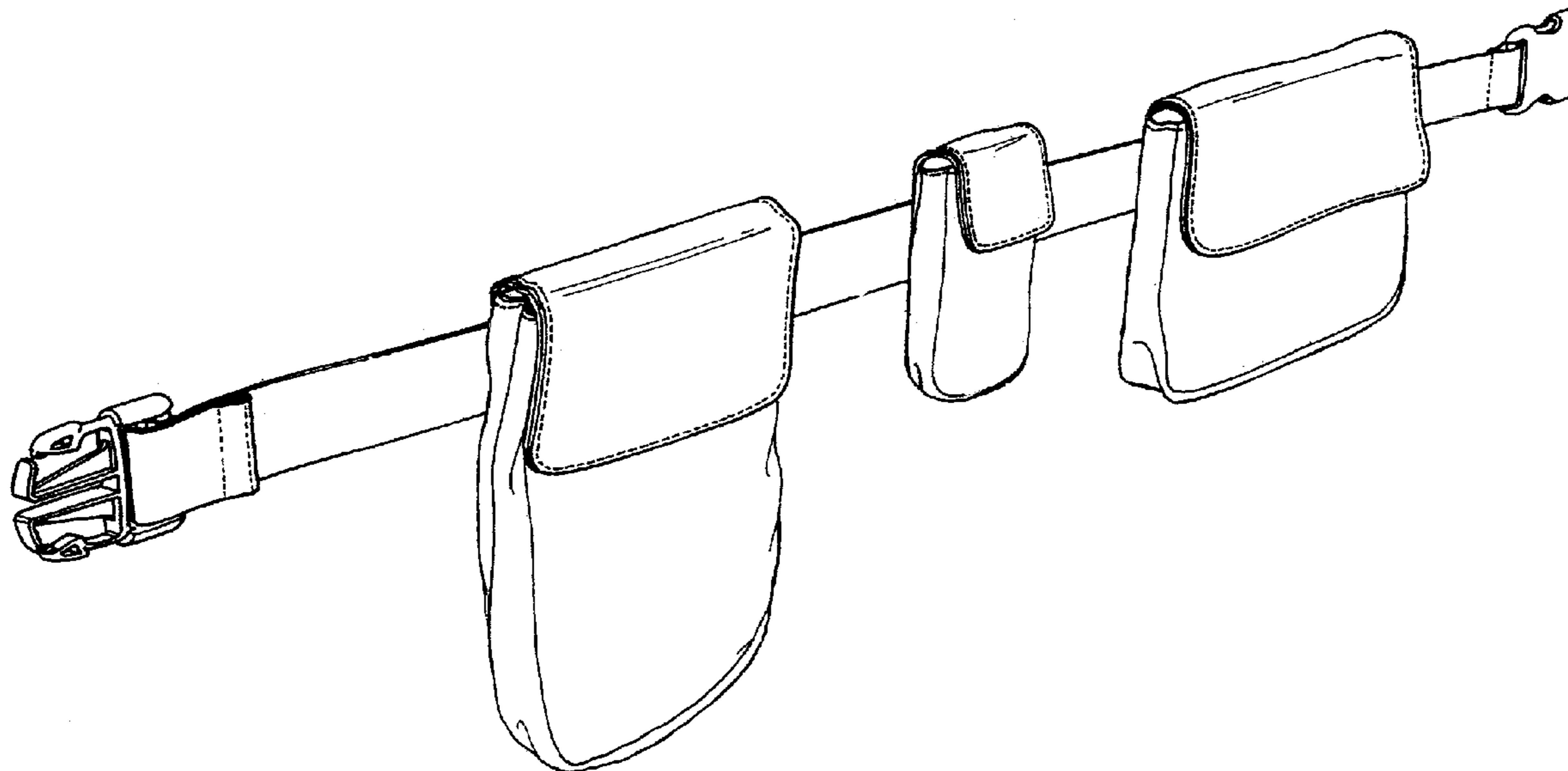

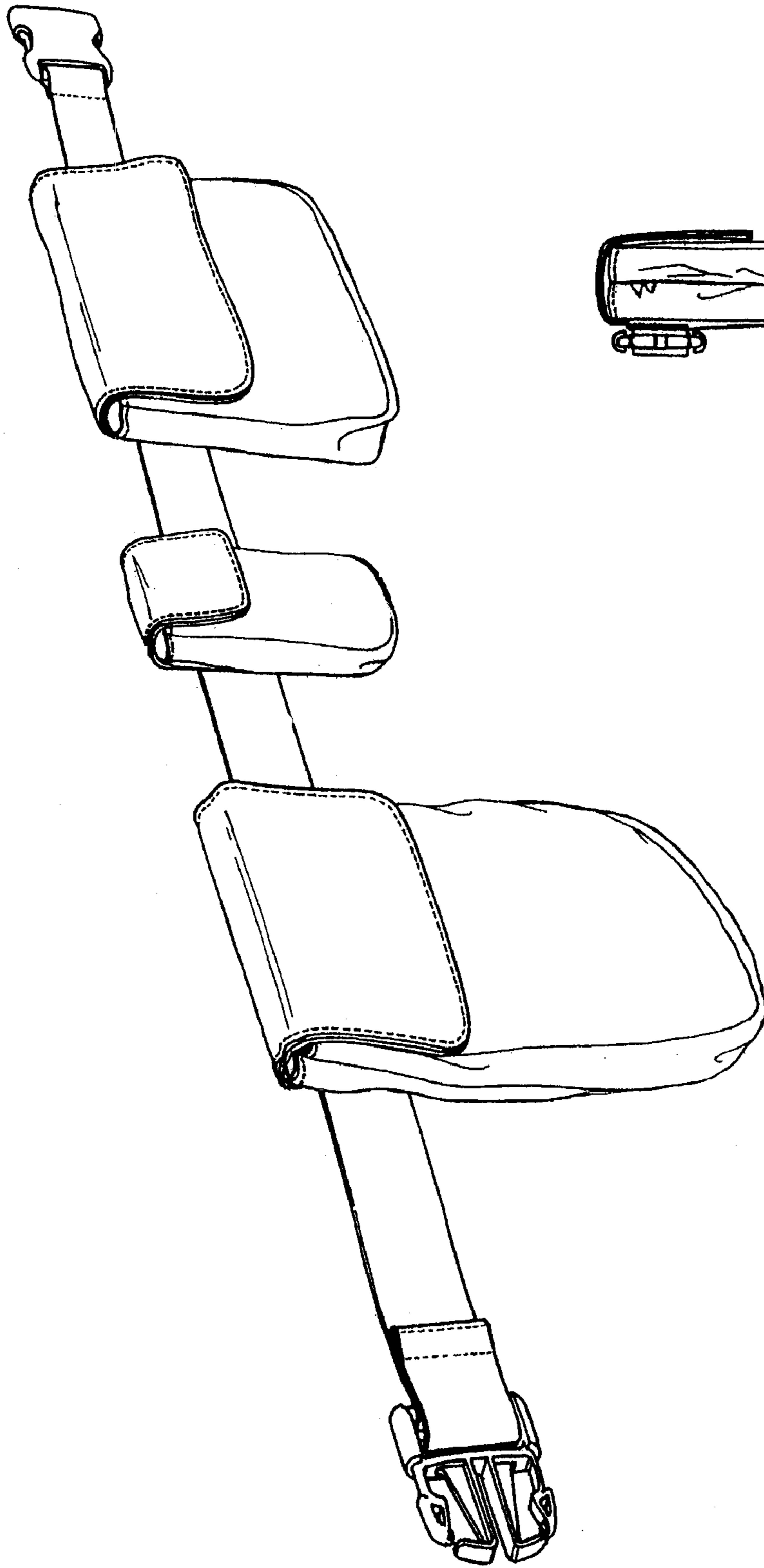

FIGURE 1

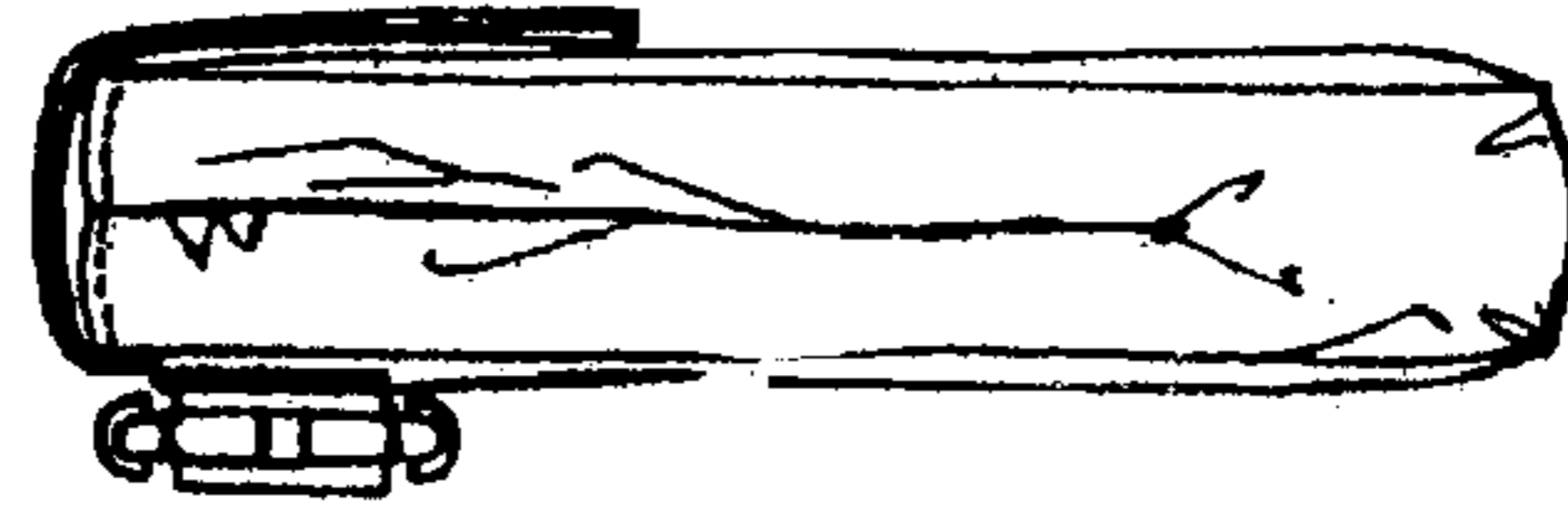

FIGURE 2

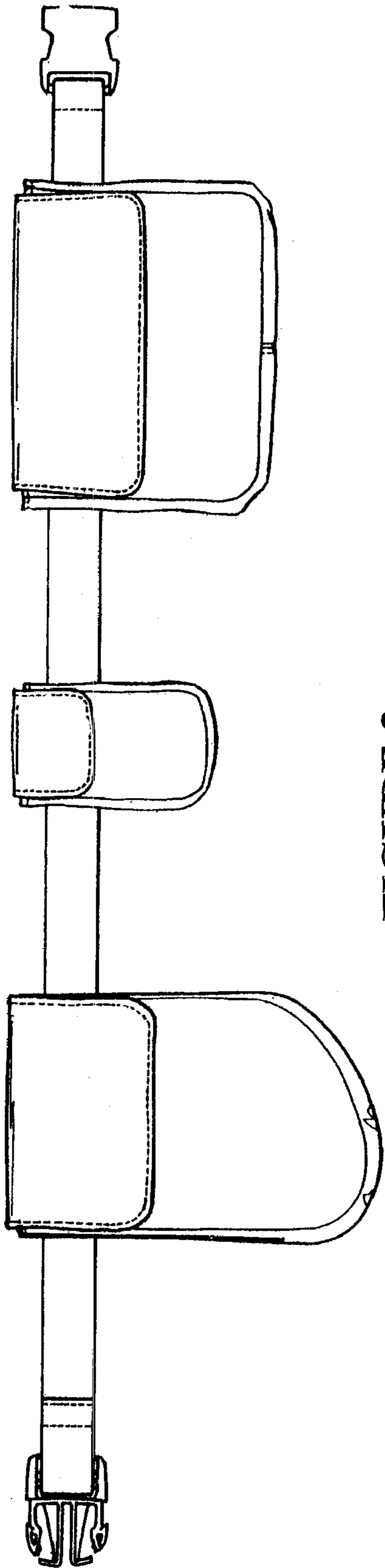

FIGURE 3

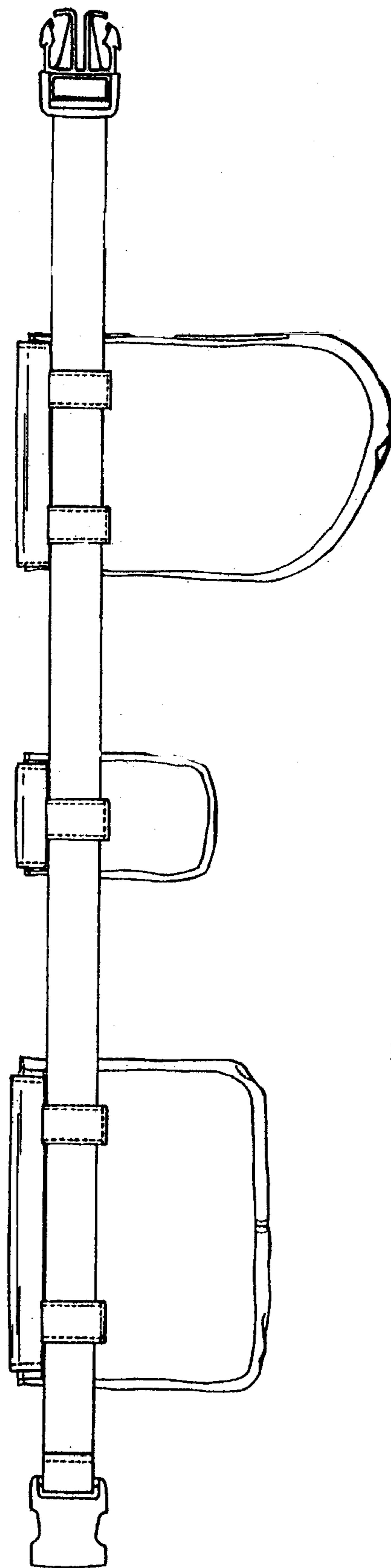

FIGURE 4

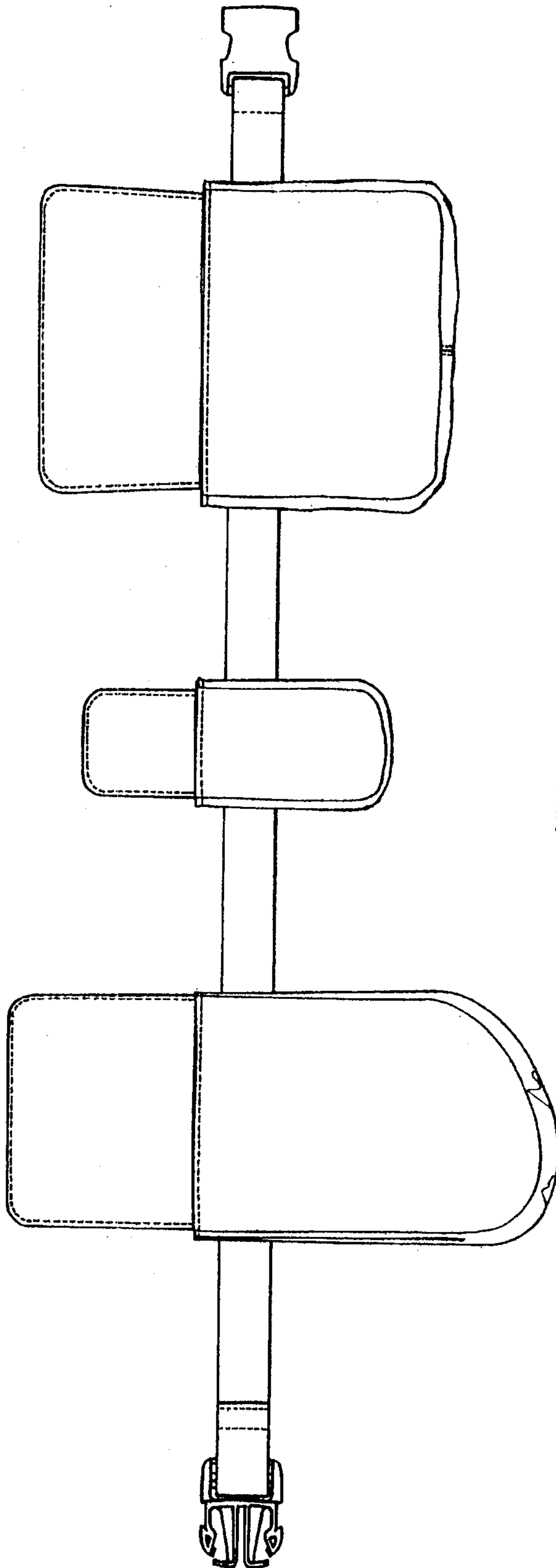

FIGURE 5



FIGURE 6