



US00D533728S

(12) **United States Design Patent**
Martin

(10) **Patent No.:** **US D533,728 S**

(45) **Date of Patent:** **** Dec. 19, 2006**

(54) **SEAT**

(75) Inventor: **Kirt D. Martin**, Alto, MI (US)

(73) Assignee: **Steelcase Development Corporation**,
Caledonia, MI (US)

(**) Term: **14 Years**

(21) Appl. No.: **29/202,083**

(22) Filed: **Mar. 25, 2004**

(51) **LOC (8) Cl.** **06-01**

(52) **U.S. Cl.** **D6/372; D6/355**

(58) **Field of Classification Search** D6/334-336,
D6/356, 357, 363, 371-373, 374-376, 500-502;
248/592; 297/250.1, 298, 440.1, 452.12,
297/452.13

See application file for complete search history.

(56) **References Cited**

U.S. PATENT DOCUMENTS

778,223	A	*	12/1904	Cox	297/250.1
1,652,942	A		12/1927	James		
D168,430	S		12/1952	Wright		
D184,360	S	*	2/1959	Casimir	D6/356
D193,338	S		8/1962	Tepper		
D199,304	S	*	10/1964	Rhoades	D6/375
3,574,400	A		4/1971	Day		
D224,856	S		10/1972	Charity		
3,712,670	A	*	1/1973	Svehla et al.	297/250.1
D226,589	S	*	3/1973	Svehla et al.	D6/356
D229,370	S		11/1973	Berger		
D235,288	S	*	6/1975	Sullican	D6/357
D237,662	S		11/1975	Subert		
D244,108	S	*	4/1977	Bacon	D6/372
D249,989	S		10/1978	Radaelli		

D288,506	S		3/1987	Ochsner		
D296,047	S	*	6/1988	Kucera et al.	D6/374
D333,044	S		2/1993	Caruso		
D368,594	S		4/1996	Settambrino		
D383,913	S		9/1997	Ahlstrom		
D414,618	S		10/1999	Holbrook		
D453,642	S		2/2002	Mascheroni		

OTHER PUBLICATIONS

“Rocking Chairs” from www.designboom.com/rocking/hu-lot.html, 3 pages.

“Knoll Museum” from www.knoll.com/museum/exhibits/saarinen151c.jsp, 3 pages.

* cited by examiner

Primary Examiner—Mimosa De

(74) *Attorney, Agent, or Firm*—Price, Heneveld, Cooper, DeWitt & Litton, LLP

(57) **CLAIM**

I claim the ornamental design for the seat, as shown and described.

DESCRIPTION

FIG. 1 is a perspective view showing a front, top, and side of the seat of the present invention;
FIG. 2 is a front elevational view of the seat;
FIG. 3 is an elevational view of a side of the seat;
FIG. 4 is a rear elevational view of the seat;
FIG. 5 is a top plan view of the seat; and,
FIG. 6 is a bottom plan view of the seat.
The elevational view of the first side as shown in FIG. 3 is a mirror image of the opposite side of the seat.
The dashed lines within the figures are for illustrative purposes only and form no part of the claimed invention.

1 Claim, 2 Drawing Sheets

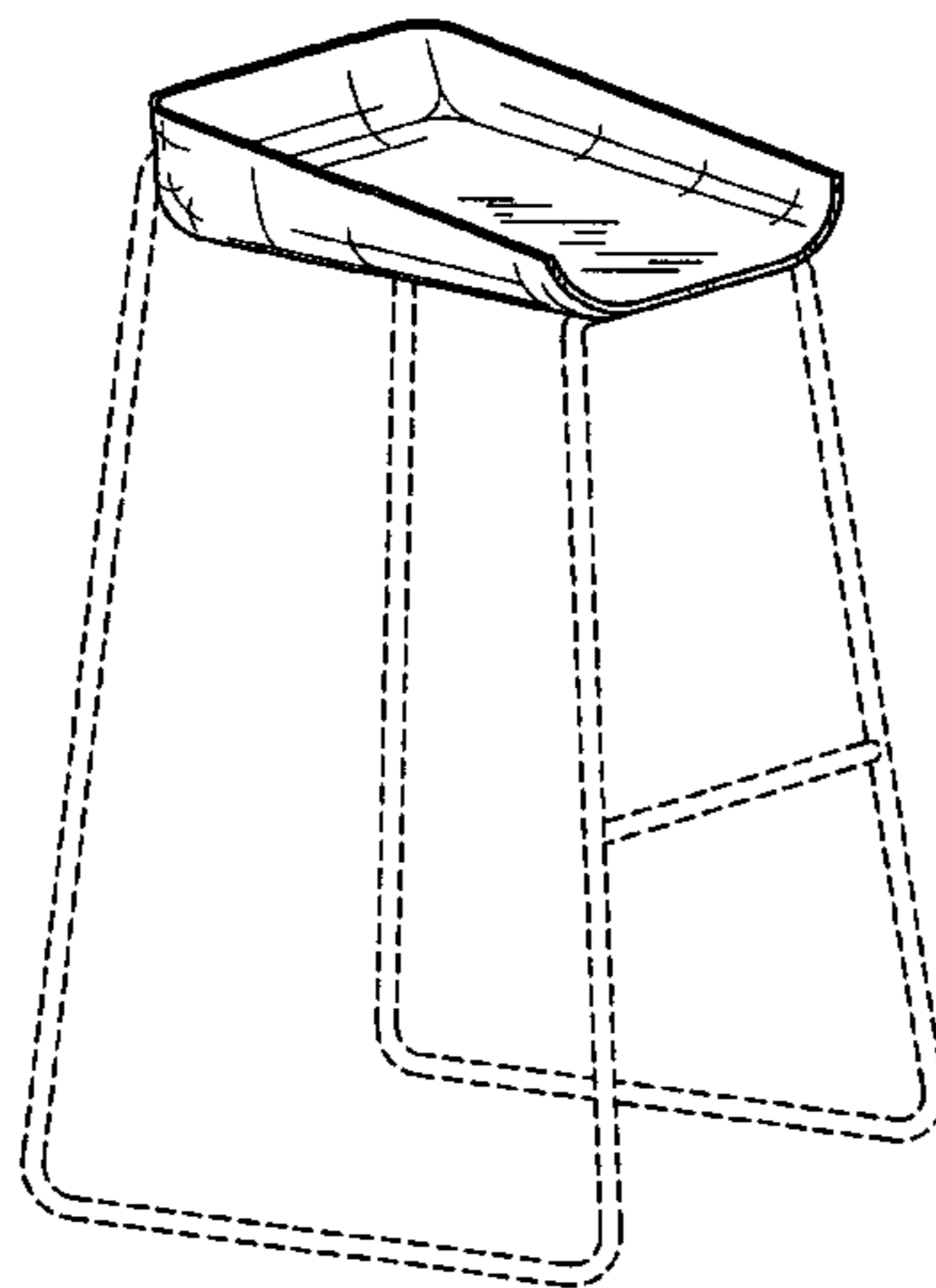

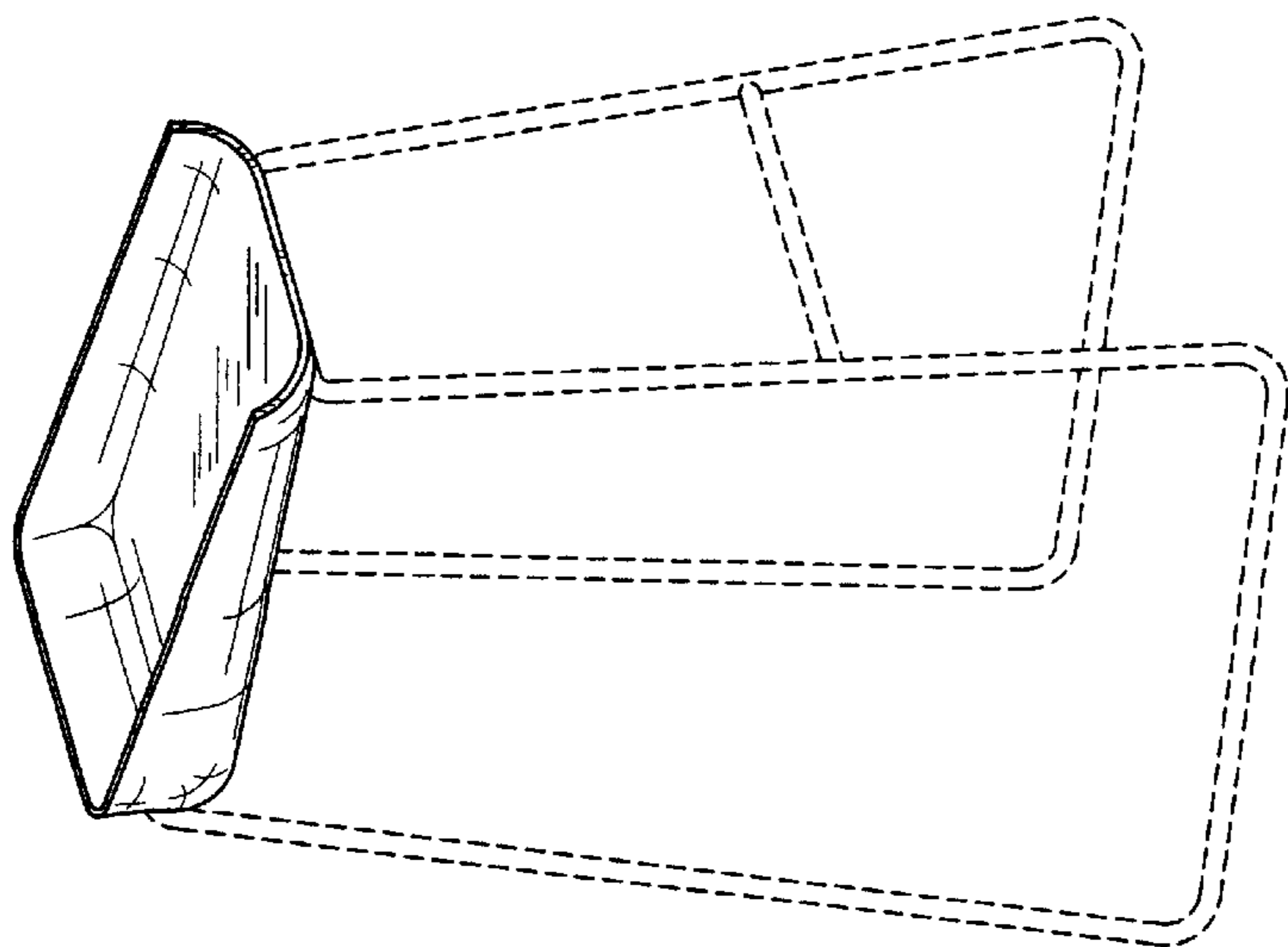

FIG. 1

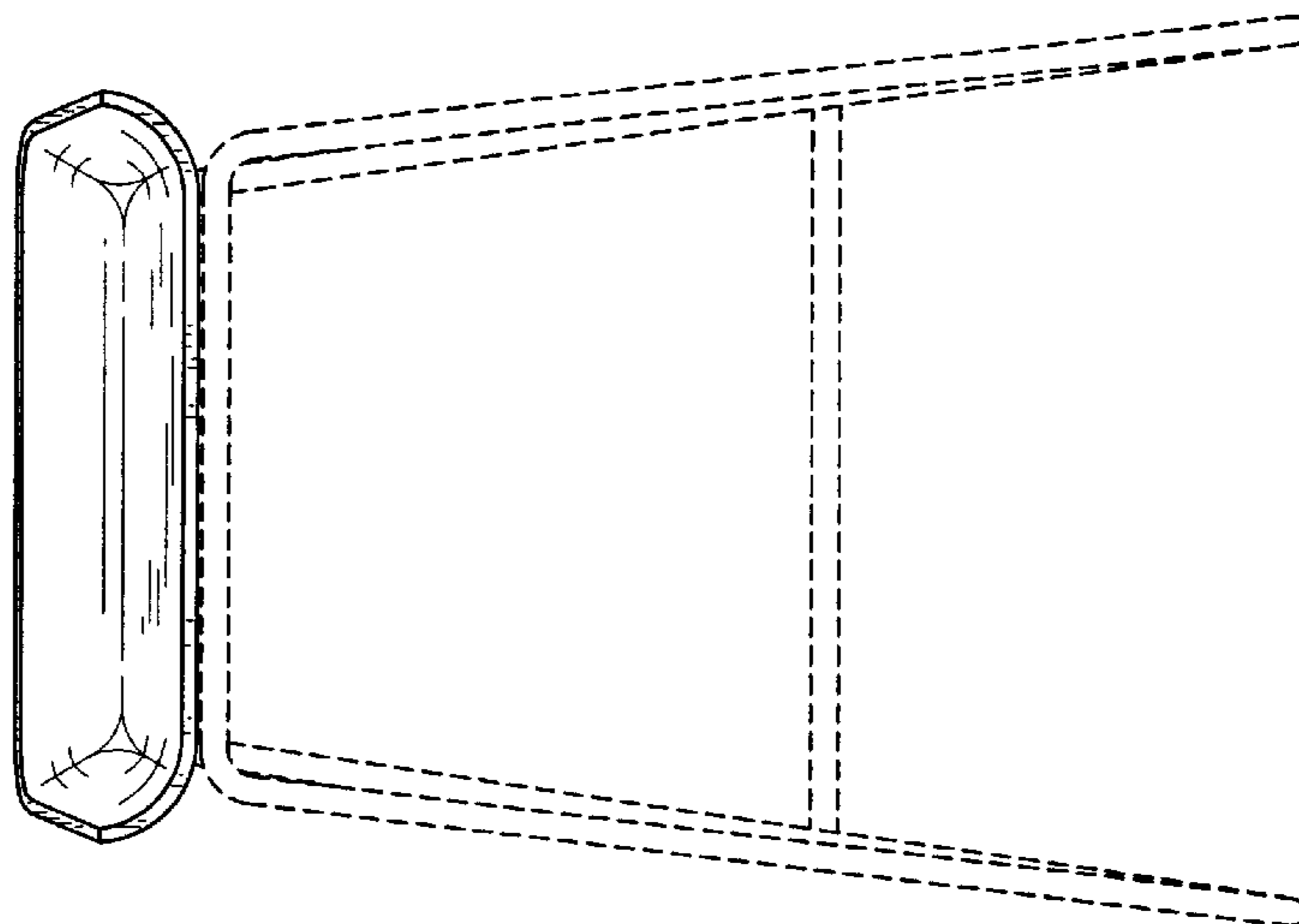

FIG. 2

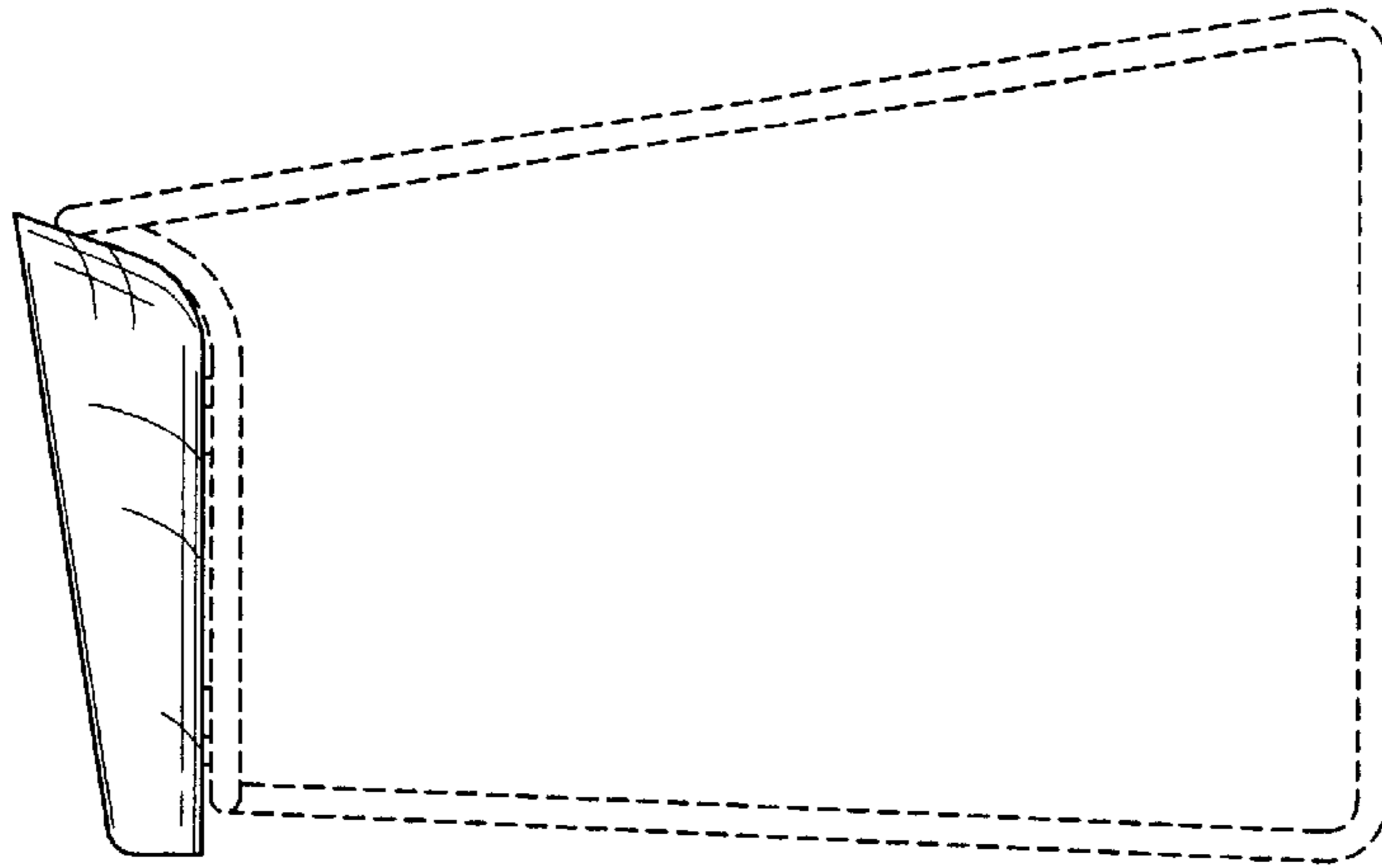

FIG. 3

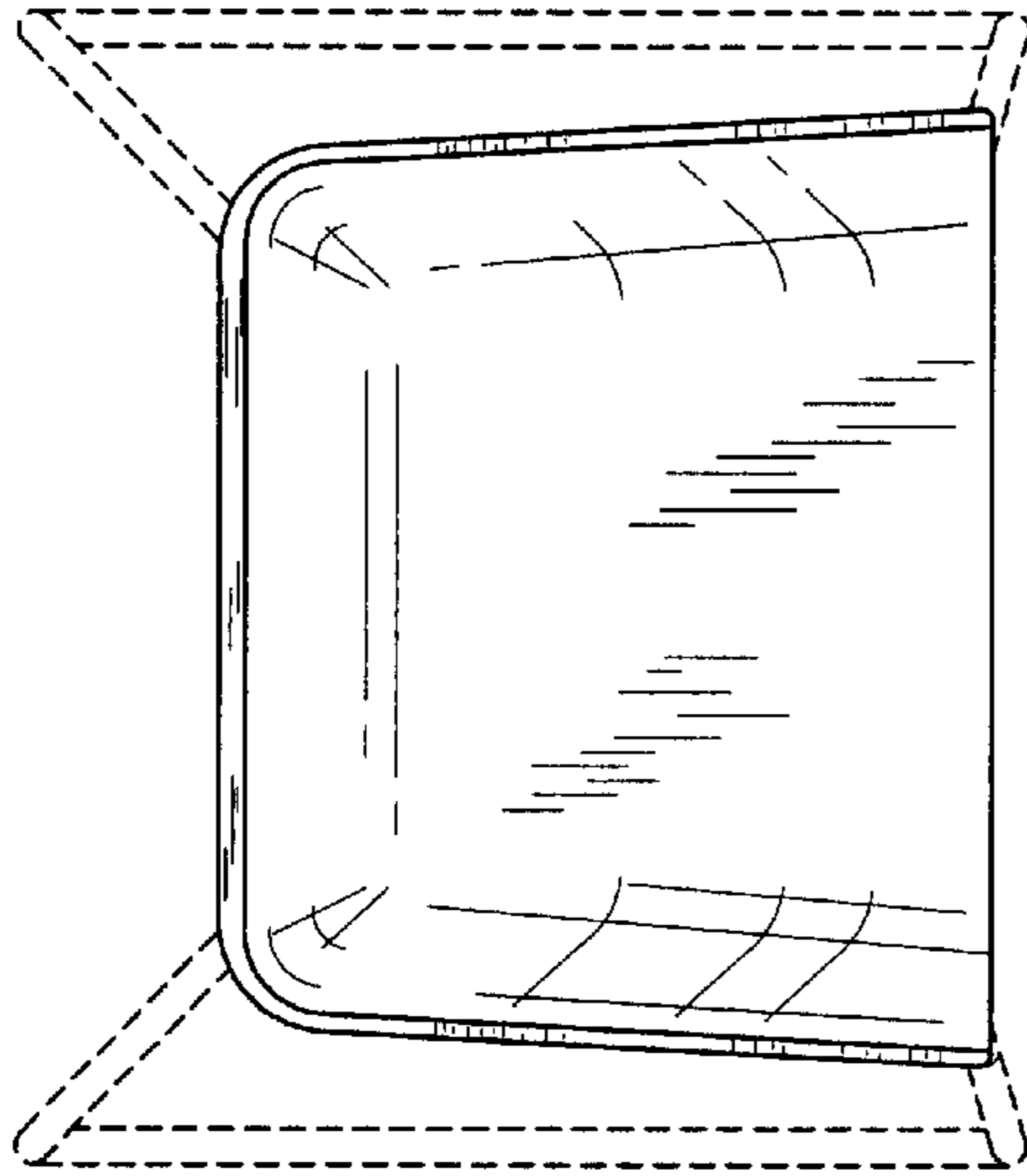

FIG. 5

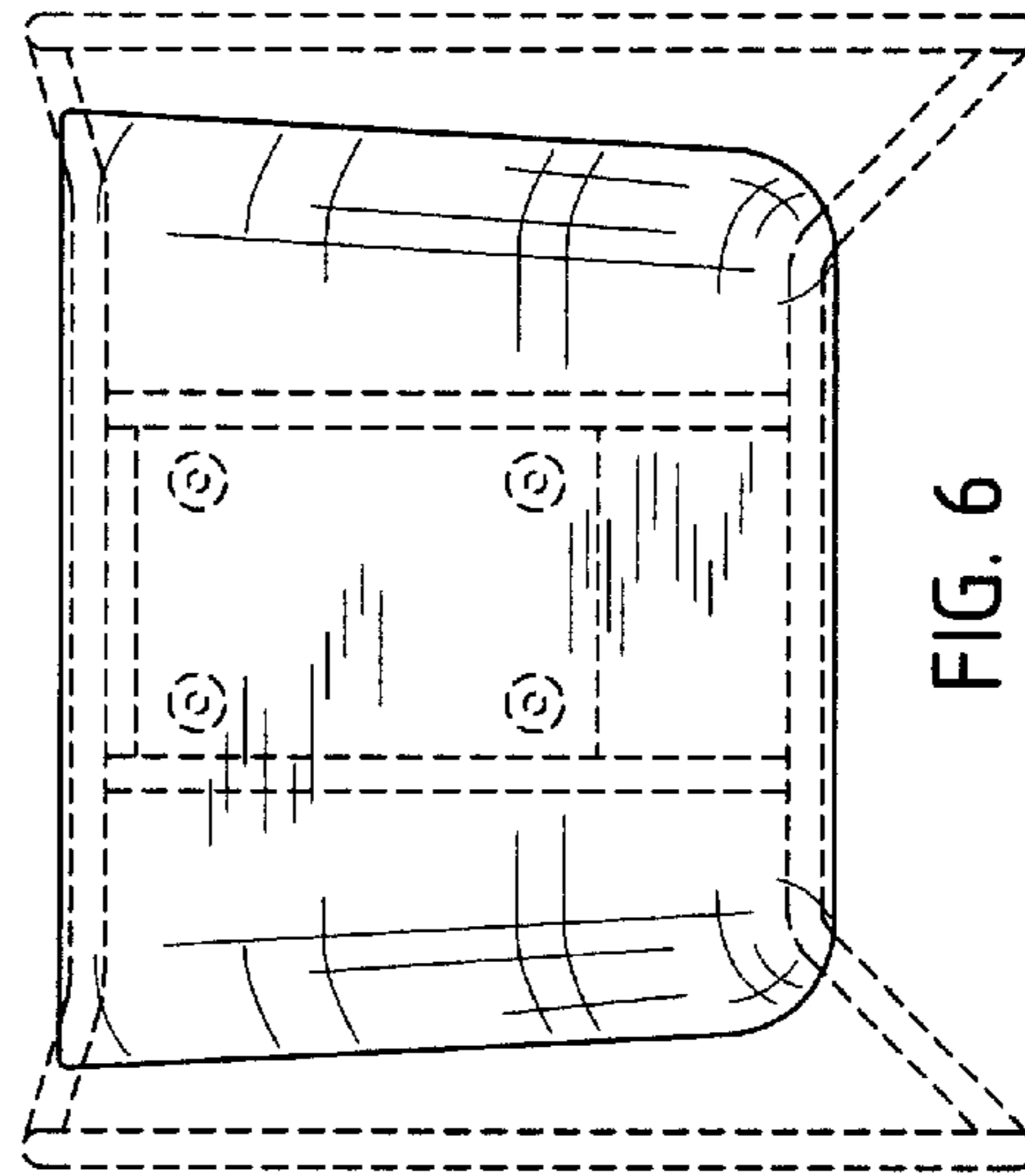

FIG. 6

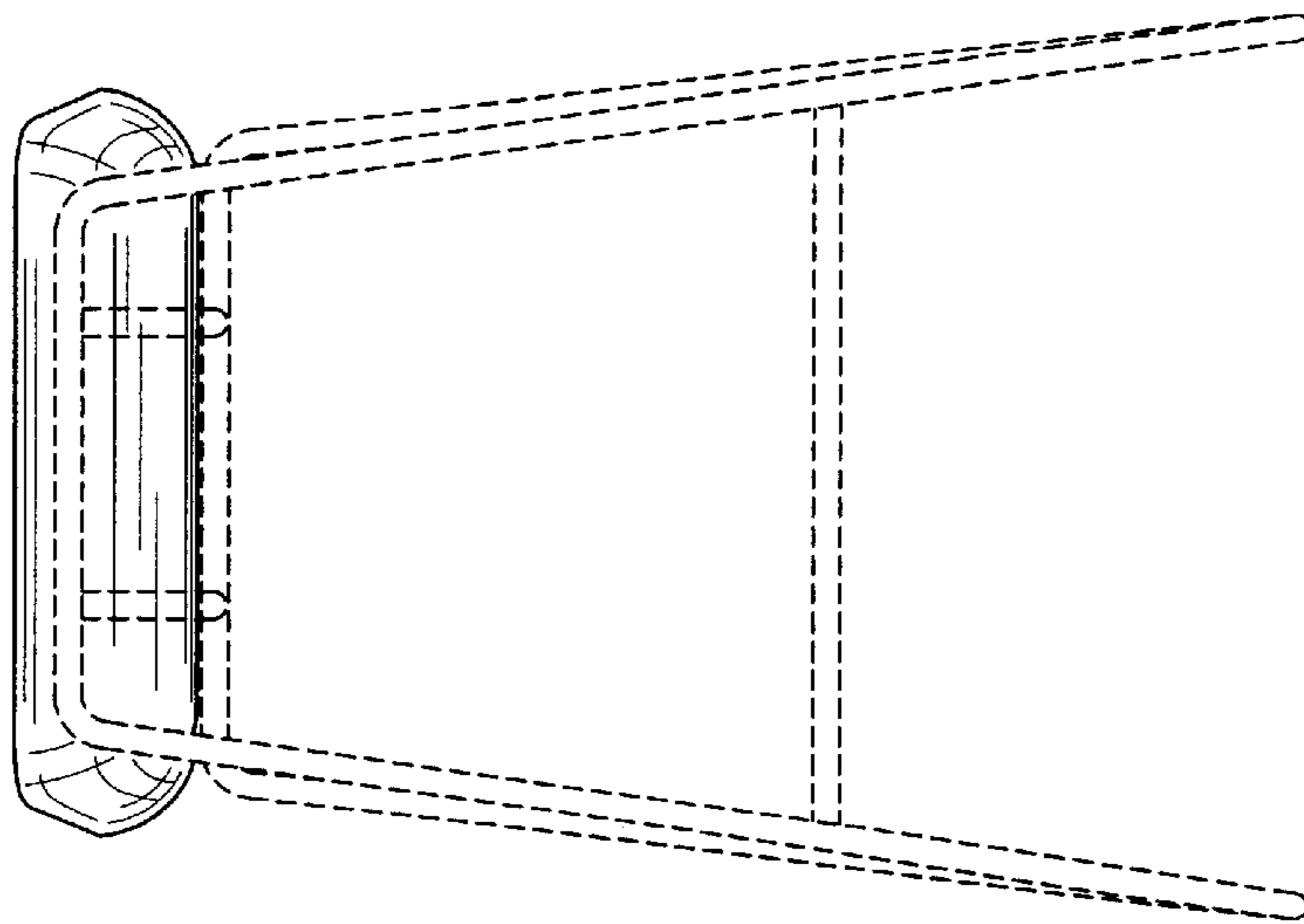

FIG. 4